

FEATURES

- R_{SENSE} : $50m\Omega \pm 0.5\%$
- Fully Assembled and Tested
- 2in x 2in 2-layer circuit board

COMPONENT LIST

DESIGNATION	QTY	DESCRIPTION
C2	1	47nF $\pm 10\%$ capacitor (0805)
R1	1	50m $\Omega \pm 1\%$ (0805)
U1	1	TS1101-25DB/ TS1101-50DB/ TS1101-100DB/ TS1101-200DB
VDD, VBATT, VOUT, SIGN, LOAD	5	Test points

DESCRIPTION

The demo board for the TS1101 is a completely assembled and tested circuit board that can be used for evaluating the bidirectional current-sense amplifier for all (4) gain options; i.e., 25V/V, 50V/V, 100V/V, and 200V/V.

The board is configured with an $R_{SENSE} = R1 = 50m\Omega$ resistor. The board has a dedicated $RS+ = VBATT$, $RS- = LOAD$, output voltage $OUT = VOUT$, VDD, and SIGN test points. For additional information, refer to the TS1101 product data sheet.

All TS1101s are available in a PCB-space saving 6-lead SOT23 surface-mount package.

Product data sheets and additional documentation can be found at www.silabs.com.

ORDERING INFORMATION

Order Number	Description
TS1101-25DB	TS1101-XXX Demo Board
TS1101-50DB	
TS1101-100DB	
TS1101-200DB	

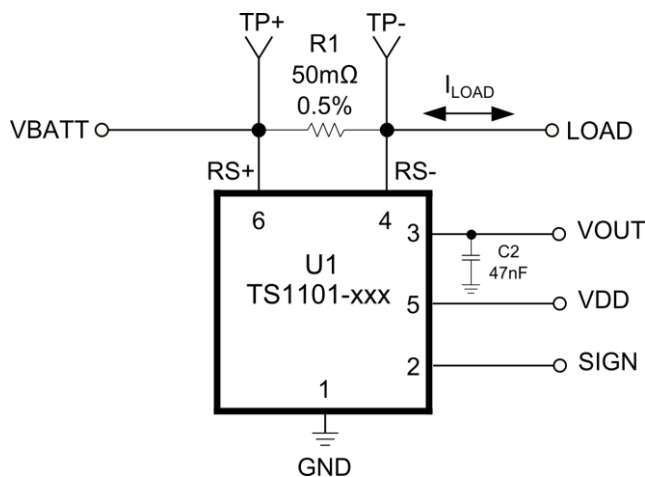

Figure 1. TS1101 Bidirectional Current-Sense Amplifier Circuit



Figure 2. TS1101 Demo Board

DESCRIPTION

The TS1101 demo board includes decoupling capacitor pads, C1, at the VBATT input pin and a 47nF capacitor at the VOUT output pin. Because the TS1101 is a bidirectional current-sense amplifier, the demo board can be set-up to sense current in both directions. Please refer to Table 2 for the proper connections of VBATT and LOAD test points. The direction of the current is known based on the voltage level of the SIGN pin. If $V_{RS+} > V_{RS-}$, the SIGN pin is a logic HIGH or VDD voltage. If $V_{RS-} > V_{RS+}$, the SIGN pin is a logic LOW or GND voltage. A VDD test point is available and powers the internal comparator that monitors the direction of the load current. The output voltage of the comparator is the voltage on the SIGN pin.

QUICK START PROCEDURE

Required Equipment

- A TS1101 demo board
- A dual output, DC power supply, an HP Model HP6624A or equivalent
- Three digital voltmeters
- A load resistor or an active load (value varies depending on I_{LOAD} desired)

Signal	Demo board
RS+	VBATT
RS-	LOAD
OUT	VOUT
GND	GND
VDD	VDD
SIGN	SIGN

Table 1. Demo Board Test Points

Test Point	$V_{RS+} > V_{RS-}$	$V_{RS-} > V_{RS+}$
VBATT	input voltage	load
LOAD	load	input voltage

Table 2. VBATT and LOAD Test Point Connections Per I_{LOAD} Direction

GAIN (V/V)	V_{BATT} (V)	I_{LOAD} (mA)	V_{DD} (V)	R_{LOAD} (Ω)	V_{OUT} (V)	MAX V_{SENSE} (mV)
25	6	1600	1.8	3.75	2	80
50	6	800	1.8	7.5	2	40
100	6	400	1.8	15	2	20
200	6	200	1.8	30	2	10

Table 3. Demo Board Test Set-Up Per Gain Setting

To evaluate the TS1101 bidirectional current-sense amplifier circuit, the following steps are to be performed:

- 1) Before connecting the DC power supply to the demo board, turn on the power supply, set the DC voltage to 6V on one output and the other to 1.8V. Set the short circuit current limit on each output to 10% higher than the maximum load current in the application, and then turn it off.
- 2) For applications where $V_{RS+} > V_{RS-}$, connect the 6V DC power supply positive terminal to the test point VBATT and its negative terminal to the test point GND. Connect the 1.8V power supply positive terminal to the test point VDD and its negative terminal to the test point GND. See Table 2 for applications where $V_{RS-} > V_{RS+}$.
- 3) Connect a digital voltmeter to the test points TP+ and TP- to measure V_{SENSE} .
- 4) Connect the positive terminal of a second digital voltmeter to the test point VOUT and the negative terminal to the test point GND.
- 5) To monitor the direction of the current, connect the positive terminal of a third digital voltmeter to the test point SIGN and the negative terminal to the test point GND.
- 6) Based on the selected gain option of the current sense amplifier, select the load resistor or an active load according to Table 3. Connect one end of this resistor or active load to the test point LOAD and the other end to the test point GND.
- 7) Turn on the power supply and observe the output voltage at VOUT. The expression for the TS1101's output voltage is given by:

$$V_{OUT} = I_{LOAD} \times 50m\Omega \times \frac{R_{OUT}}{R_{GAIN}[A/B]}$$

where the TS1101's internal R_{OUT} and $R_{GAIN}[A/B]$ resistor values are listed in Table 4.

GAIN(V/V)	$R_{GAIN}[A/B]$ (Ω)	R_{OUT} (Ω)
25	400	10k
50	200	10k
100	100	10k
200	100	20k

Table 4. TS1101's Internal Gain Setting Resistors (typical values)



SILICON LABS TS1101 Bidirectional Current-Sense Amplifier Demo Board

8) The TS1101's actual output voltage V_{OUT} will depend on the TS1101's actual offset voltage V_{OS} , its gain error GE , sense resistor (R_{SENSE}) tolerance of $\pm 1\%$, and the load resistor tolerance/active load accuracy.

Note: For applications where $V_{RS} > V_{RS+}$, connect test points VBATT and LOAD based on Table 2 and follow the steps above.

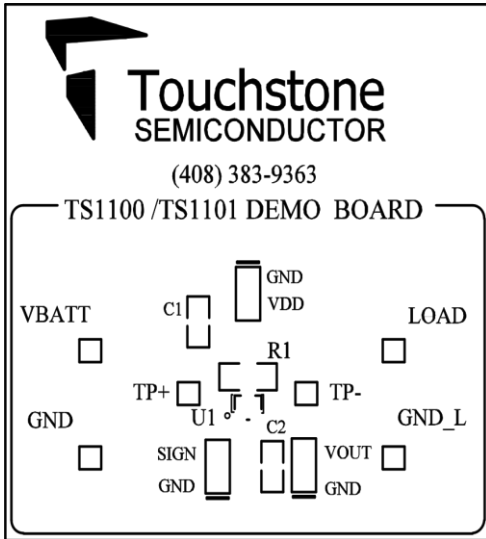

Figure 3. Top Layer Component View

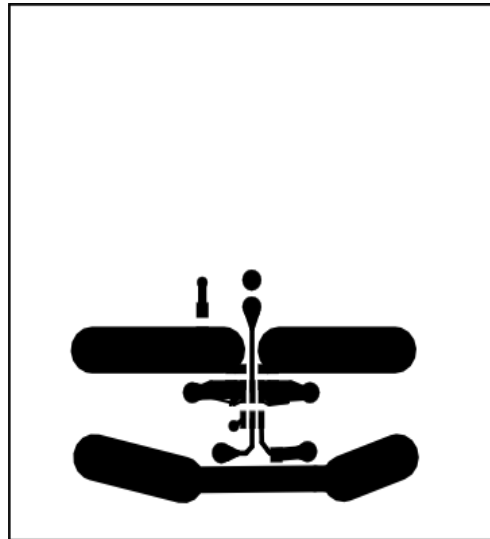

Figure 4. Top Layer Component View #2

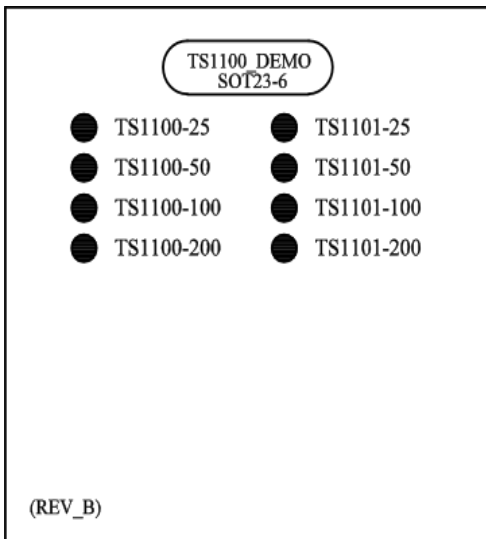

Figure 5. Bottom Layer (GND)

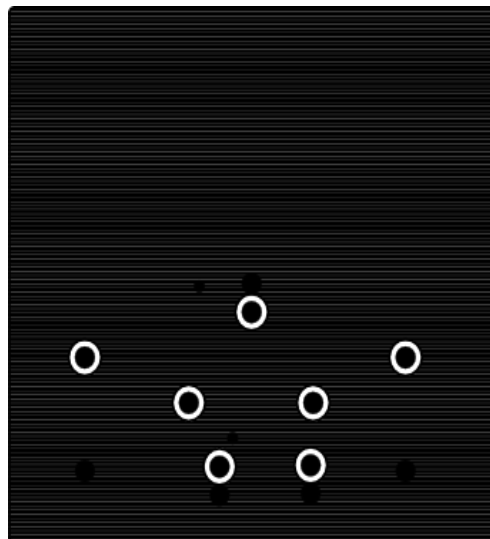

Figure 6. Bottom Layer (GND) #2