

ACPL-330J

1.5 Amp Output Current IGBT Gate Driver Optocoupler with Integrated (V_{CE}) Desaturation Detection, UVLO, Fault Feedback, Active Miller Clamp and Auto-Fault Reset



Data Sheet



Lead (Pb) Free
RoHS 6 fully compliant

RoHS 6 fully compliant options available;
-xxxE denotes a lead-free product

Description

The ACPL-330J is an advanced 1.5 A output current, easy-to-use, intelligent gate driver which makes IGBT V_{CE} fault protection compact, affordable, and easy-to implement. Features such as integrated V_{CE} detection, under voltage lockout (UVLO), “soft” IGBT turn-off, isolated open collector fault feedback and active Miller clamping provide maximum design flexibility and circuit protection.

The ACPL-330J contains a GaAsP LED. The LED is optically coupled to an integrated circuit with a power output stage. ACPL-330J is ideally suited for driving power IGBTs and MOSFETs used in motor control inverter applications. The voltage and current supplied by these optocouplers make them ideally suited for directly driving IGBTs with ratings up to 1200 V and 100 A. For IGBTs with higher ratings, the ACPL-330J can be used to drive a discrete power stage which drives the IGBT gate. The ACPL-330J has an insulation voltage of $V_{IORM} = 891 V_{PEAK}$.

Block Diagram

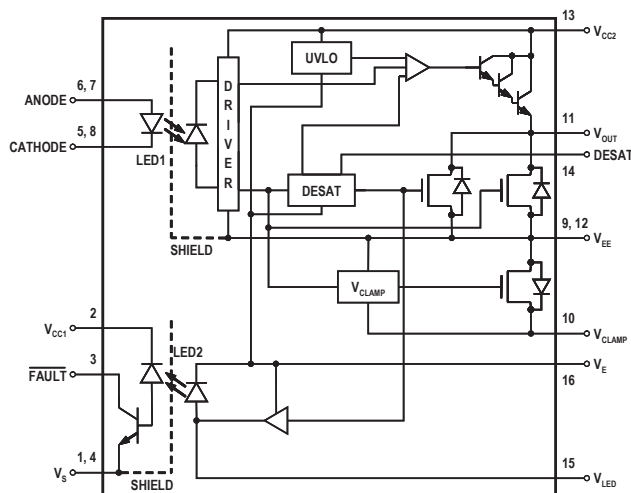

Features

- 1.5 A maximum peak output current
- 1.0 A minimum peak output current
- 250 ns maximum propagation delay over temperature range
- 1.0A Active Miller Clamp. Clamp pin short to V_{EE} if not in used
- Miller Clamping
- Desaturation Detection
- Under Voltage Lock-Out Protection (UVLO) with Hysteresis
- Open Collector Isolated fault feedback
- “Soft” IGBT Turn-off
- Automatic Fault Reset after fixed Mute Time , typically 26 μ s
- Available in SO-16 package
- 100 ns maximum pulse width distortion (PWD)
- 15 kV/ μ s minimum common mode rejection (CMR) at $V_{CM} = 1500 V$
- $I_{CC(max)} < 5 mA$ maximum supply current
- Wide V_{CC} operating range: 15 V to 30 V over temperature range
- Wide operating temperature range: $-40^{\circ}C$ to $105^{\circ}C$
- Pending Safety Approvals:: UL, 3750 V_{RMS} for 1 minute, CSA, IEC/EN/DIN-EN 60747-5-2 $V_{IORM} = 891 V_{PEAK}$

Applications

- Isolated IGBT/Power MOSFET gate drive
- AC and brushless DC motor drives
- Industrial inverters and Uninterruptible Power Supply (UPS)

CAUTION: It is advised that normal static precautions be taken in handling and assembly of this component to prevent damage and/or degradation which may be induced by ESD.

Pin Description

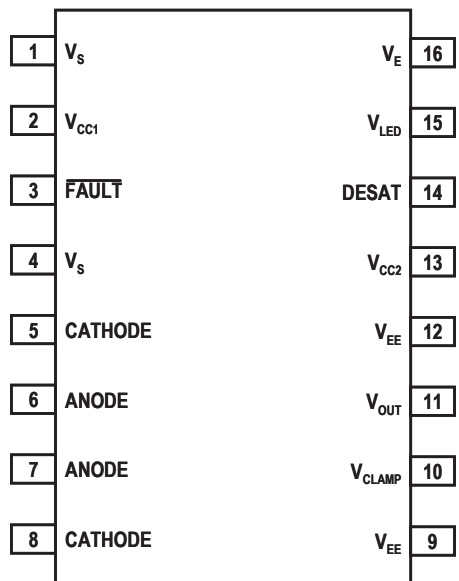

Pin	Symbol	Description
1	V _S	Input Ground
2	V _{CC1}	Positive input supply voltage. (4.5 V to 5.5 V)
3	$\overline{\text{FAULT}}$	Fault output. $\overline{\text{FAULT}}$ changes from a high impedance state to a logic low output within 5 μs of the voltage on the DESAT pin exceeding an internal reference voltage of 6.5 V. $\overline{\text{FAULT}}$ output is an open collector which allows the $\overline{\text{FAULT}}$ outputs from all ACPL-330J in a circuit to be connected together in a "wired OR" forming a single fault bus for interfacing directly to the micro-controller.
4	V _S	Input Ground
5	CATHODE	Cathode
6	ANODE	Anode
7	ANODE	Anode
8	CATHODE	Cathode
9	V _{EE}	Output supply voltage.
10	V _{CLAMP}	Miller clamp
11	V _{OUT}	Gate drive voltage output
12	V _{EE}	Output supply voltage.
13	V _{CC2}	Positive output supply voltage
14	DESAT	Desaturation voltage input. When the voltage on DESAT exceeds an internal reference voltage of 6.5 V while the IGBT is on, $\overline{\text{FAULT}}$ output is changed from a high impedance state to a logic low state within 5 μs .
15	V _{LED}	LED anode. This pin must be left unconnected for guaranteed data sheet performance. (For optical coupling testing only)
16	V _E	Common (IGBT emitter) output supply voltage.

Ordering Information

ACPL-330J is UL Recognized with 3750 Vrms for 1 minute per UL1577.

Part number	Option	Package	Surface Mount	Tape & Reel	IEC/EN/DIN EN	Quantity
	RoHS Compliant				60747-5-2	
ACPL-330J	-000E	SO-16	X		X	45 per tube
	-500E				X	850 per reel

To order, choose a part number from the part number column and combine with the desired option from the option column to form an order entry.

Example 1:

ACPL-330J-500E to order product of SO-16 Surface Mount package in Tape and Reel packaging with IEC/EN/DIN EN 60747-5-2 Safety Approval in RoHS compliant.

Example 2:

ACPL-330J-000E to order product of SO-16 Surface Mount package in tube packaging with IEC/EN/DIN EN 60747-5-2 Safety Approval and RoHS compliant.

Option datasheets are available. Contact your Avago sales representative or authorized distributor for information.

Remarks: The notation '#XXX' is used for existing products, while (new) products launched since 15th July 2001 and RoHS compliant option will use '-XXE'.

Package Outline Drawings

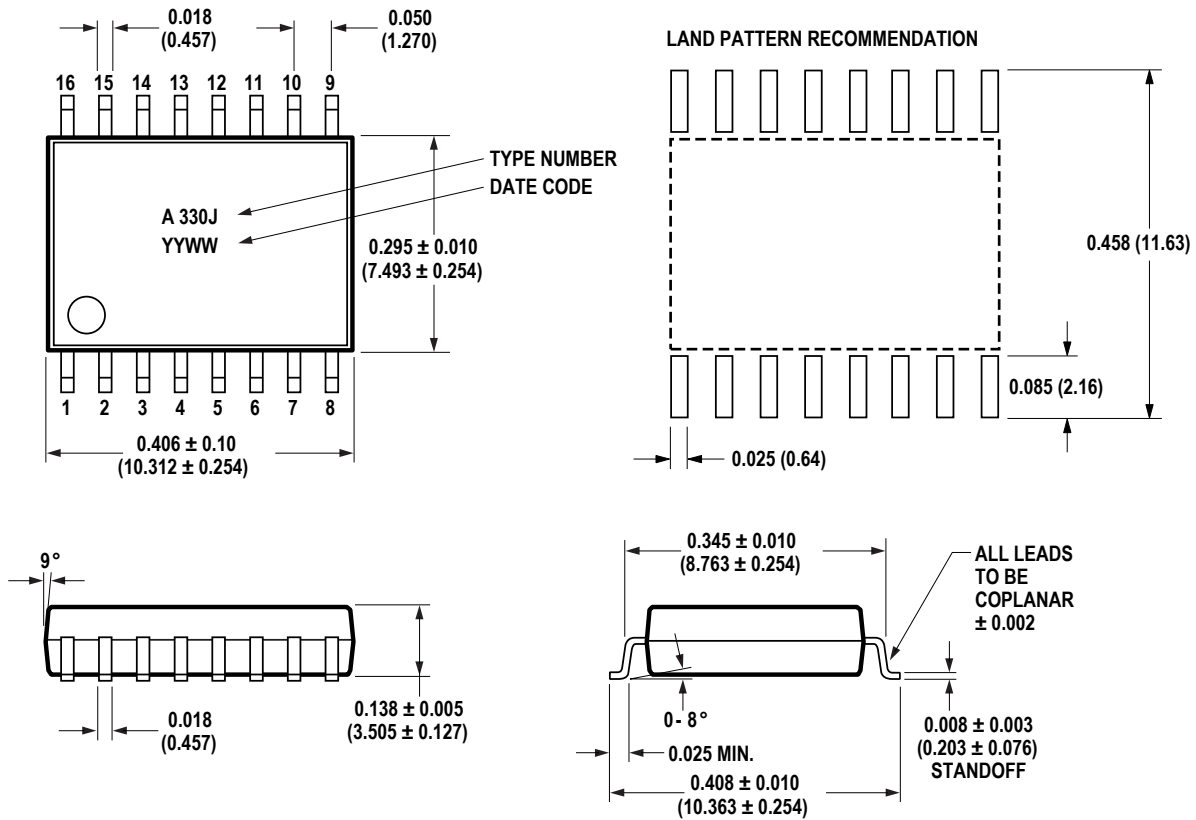

ACPL-330J 16-Lead Surface Mount Package

Dimensions in inches (millimeters)

Notes: Initial and continued variation in the color of the ACPL-330J's white mold compound is normal and does not affect device performance or reliability.

Floating Lead Protrusion is 0.25 mm (10 mils) max.

Solder Reflow Thermal Profile

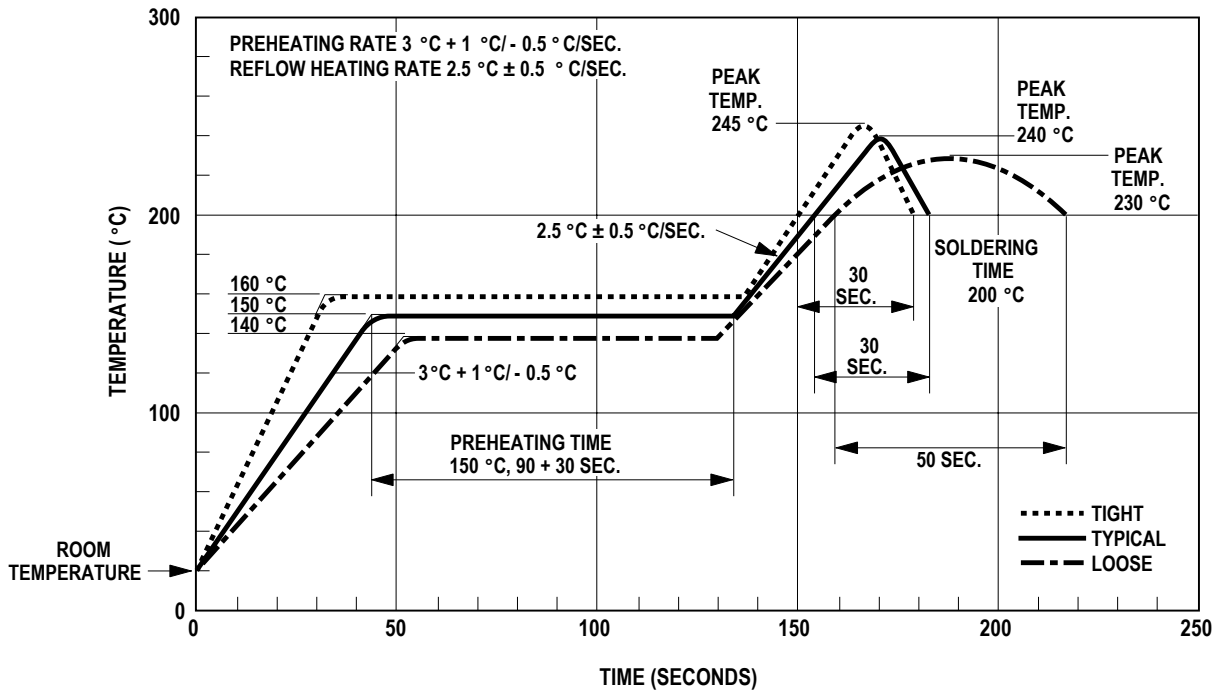

Note: Non-halide flux should be used.

Recommended Pb-Free IR Profile

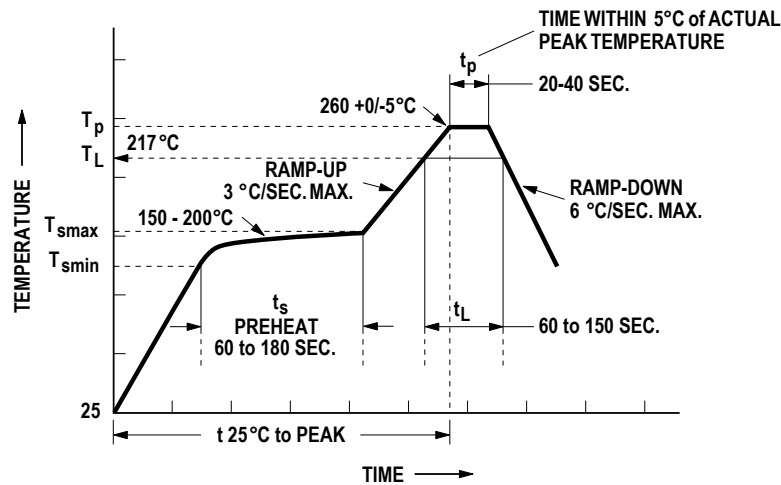

NO TES:
 THE TIME FROM 25°C TO PEAK TEMPERATURE = 8 MINUTES MAX.
 $T_{smax} = 200°C$, $T_{smin} = 150°C$

Note: Non-halide flux should be used.

Regulatory Information

The ACPL-330J is pending approval by the following organizations:

IEC/EN/DIN EN 60747-5-2

Approval under:

IEC 60747-5-2:1997 + A1:2002

EN 60747-5-2:2001 + A1:2002

DIN EN 60747-5-2 (VDE 0884 Teil 2):2003-01

UL

Approval under UL 1577, component recognition program up to VISO = 3750 VRMS. File E55361.

CSA

Approval under CSA Component Acceptance Notice #5, File CA 88324.

Table 1. IEC/EN/DIN EN 60747-5-2 Insulation Characteristics*

Description	Symbol	Characteristic	Unit
Installation classification per DIN VDE 0110/1.89, Table 1 for rated mains voltage $\leq 150 V_{rms}$ for rated mains voltage $\leq 300 V_{rms}$ for rated mains voltage $\leq 600 V_{rms}$		I – IV I – IV I – III	
Climatic Classification		55/100/21	
Pollution Degree (DIN VDE 0110/1.89)		2	
Maximum Working Insulation Voltage	V_{IORM}	891	V_{peak}
Input to Output Test Voltage, Method b**, $V_{IORM} \times 1.875 = V_{PR}$, 100% Production Test with $t_m = 1$ sec, Partial discharge < 5 pC	V_{PR}	1670	V_{peak}
Input to Output Test Voltage, Method a**, $V_{IORM} \times 1.5 = V_{PR}$, Type and Sample Test, $t_m = 60$ sec, Partial discharge < 5 pC	V_{PR}	1336	V_{peak}
Highest Allowable Overvoltage (Transient Overvoltage $t_{ini} = 10$ sec)	V_{IOTM}	6000	V_{peak}
Safety-limiting values – maximum values allowed in the event of a failure			
Case Temperature	T_S	175	$^{\circ}C$
Input Current	$I_{S, INPUT}$	400	mA
Output Power	$P_{S, OUTPUT}$	1200	mW
Insulation Resistance at $T_S, V_{IO} = 500$ V	R_S	$> 10^9$	Ω

* Isolation characteristics are guaranteed only within the safety maximum ratings which must be ensured by protective circuits in application. Surface mount classification is class A in accordance with CECCO0802.

** Refer to the optocoupler section of the Isolation and Control Components Designer's Catalog, under Product Safety Regulations section IEC/EN/DIN EN 60747-5-2, for a detailed description of Method a and Method b partial discharge test profiles.

Dependence of Safety Limiting Values on Temperature. (take from DS AV01-0579EN Pg.7)

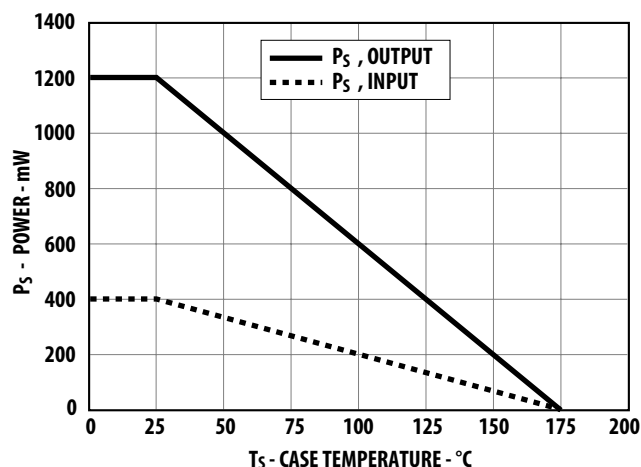

Table 2. Insulation and Safety Related Specifications

Parameter	Symbol	ACPL-330J	Units	Conditions
Minimum External Air Gap (Clearance)	L(101)	8.3	Mm	Measured from input terminals to output terminals, shortest distance through air.
Minimum External Tracking (Creepage)	L(102)	8.3	Mm	Measured from input terminals to output terminals, shortest distance path along body.
Minimum Internal Plastic Gap (Internal Clearance)		0.5	Mm	Through insulation distance conductor to conductor, usually the straight line distance thickness between the emitter and detector.
Tracking Resistance (Comparative Tracking Index)	CTI	>175	V	DIN IEC 112/VDE 0303 Part 1
Isolation Group		IIIa		Material Group (DIN VDE 0110, 1/89, Table 1)

Table 3. Absolute Maximum Ratings

Parameter	Symbol	Min.	Max.	Units	Note
Storage Temperature	T_S	-55	125	°C	
Operating Temperature	T_A	-40	105	°C	2
Output IC Junction Temperature	T_J		125	°C	2
Average Input Current	$I_{F(AVG)}$		25	mA	1
Peak Transient Input Current (<1 μ s pulse width, 300pps)	$I_{F(TRAN)}$		1.0	A	
Reverse Input Voltage	V_R		5	V	
“High” Peak Output Current	$I_{OH(PEAK)}$		1.5	A	3
“Low” Peak Output Current	$I_{OL(PEAK)}$		1.5	A	3
Positive Input Supply Voltage	V_{CC1}	-0.5	5.5	V	
FAULT Output Current	I_{FAULT}	8.0		mA	
FAULT Pin Voltage	V_{FAULT}	-0.5	V_{CC1}	V	
Total Output Supply Voltage	$(V_{CC2} - V_{EE})$	-0.5	33	V	
Negative Output Supply Voltage	$(V_E - V_{EE})$	-0.5	15	V	6
Positive Output Supply Voltage	$(V_{CC2} - V_E)$	-0.5	$33 - (V_E - V_{EE})$	V	
Gate Drive Output Voltage	$V_{O(PEAK)}$	-0.5	V_{CC2}	V	
Peak Clamping Sinking Current	I_{Clamp}		1.0	A	
Miller Clamping Pin Voltage	V_{Clamp}	-0.5	V_{CC2}	V	
DESAT Voltage	V_{DESAT}	V_E	$V_E + 10$	V	
Output IC Power Dissipation	P_O		600	mW	2
Input IC Power Dissipation	P_I		150	mW	2
Solder Reflow Temperature Profile	See Package Outline Drawings section				

Table 4. Recommended Operating Conditions

Parameter	Symbol	Min.	Max.	Units	Note
Operating Temperature	T_A	-40	105	°C	2
Total Output Supply Voltage	$(V_{CC2} - V_{EE})$	15	30	V	7
Negative Output Supply Voltage	$(V_E - V_{EE})$	0	15	V	4
Positive Output Supply Voltage	$(V_{CC2} - V_E)$	15	$30 - (V_E - V_{EE})$	V	
Input Current (ON)	$I_{F(ON)}$	8	12	mA	
Input Voltage (OFF)	$V_{F(OFF)}$	-3.6	0.8	V	

Table 5. Electrical Specifications (DC)

Unless otherwise noted, all typical values at $T_A = 25^\circ\text{C}$, $V_{CC2} - V_{EE} = 30\text{ V}$, $V_E - V_{EE} = 0\text{ V}$;
all Minimum/Maximum specifications are at Recommended Operating Conditions.

Parameter	Symbol	Min.	Typ.	Max.	Units	Test Conditions	Fig.	Note
FAULT Logic Low Output Voltage	$V_{\overline{\text{FAULTL}}}$		0.1	0.4	V	$I_{\overline{\text{FAULT}}} = 1.1\text{ mA}$, $V_{CC1} = 5.5\text{V}$		
			0.1	0.4	V	$I_{\overline{\text{FAULT}}} = 1.1\text{ mA}$, $V_{CC1} = 3.3\text{V}$		
FAULT Logic High Output Current	$I_{\overline{\text{FAULTH}}}$		0.02	0.5	μA	$V_{\overline{\text{FAULT}}} = 5.5\text{ V}$, $V_{CC1} = 5.5\text{V}$		
			0.002	0.3	μA	$V_{\overline{\text{FAULT}}} = 3.3\text{ V}$, $V_{CC1} = 3.3\text{V}$		
High Level Output Current	I_{OH}	-0.3	-0.75		A	$V_O = V_{CC2} - 4$	4, 18	5
		-1.0			A	$V_O = V_{CC2} - 15$		3
Low Level Output Current	I_{OL}	0.3	0.75		A	$V_O = V_{EE} + 2.5$	5, 19	5
		1.0			A	$V_O = V_{EE} + 15$		3
Low Level Output Current During Fault Condition	I_{OLF}	90	140	230	mA	$V_{\text{OUT}} - V_{EE} = 14\text{ V}$		6
High Level Output Voltage	V_{OH}	$V_{CC} - 2.9$	$V_{CC} - 2.0$		V	$I_O = -650\ \mu\text{A}$	2, 4, 20	7, 8, 9, 23
Low Level Output Voltage	V_{OL}		0.17	0.5	V	$I_O = 100\text{ mA}$	3, 5, 21	
Clamp Pin Threshold Voltage	V_{tClamp}		2.0		V			
Clamp Low Level Sinking Current	I_{CL}	0.21	0.7		A	$V_O = V_{EE} + 2.5$		
High Level Supply Current	I_{CC2H}		2.5	5	mA	$I_O = 0\text{ mA}$	6, 7, 23	9
Low Level Supply Current	I_{CC2L}		2.5	5	mA	$I_O = 0\text{ mA}$		
Blanking Capacitor Charging Current	I_{CHG}	0.13	-0.24	-0.33	mA	$V_{\text{DESAT}} = 2\text{ V}$	8, 24	9, 10
Blanking Capacitor Discharge Current	I_{DSCHG}	10	30		mA	$V_{\text{DESAT}} = 7.0\text{ V}$	25	
DESAT Threshold	V_{DESAT}	6	6.5	7.5	V	$V_{CC2} - V_E > V_{\text{UVLO-}}$	9, 27	9
UVLO Threshold	$V_{\text{UVLO+}}$	10.5	11.6	12.5	V	$V_O > 5\text{ V}$		7, 9, 11
	$V_{\text{UVLO-}}$	9.2	10.3	11.1	V	$V_O < 5\text{ V}$		7, 9, 12
UVLO Hysteresis	$(V_{\text{UVLO+}} - V_{\text{UVLO-}})$	0.4	1.3		V			
Threshold Input Current Low to High	I_{FLH}		2.0	8	mA	$I_O = 0\text{ mA}$, $V_O > 5\text{ V}$		
Threshold Input Voltage High to Low	V_{FHL}	0.8			V			
Input Forward Voltage	V_F	1.2	1.6	1.95	V	$I_F = 10\text{ mA}$		
Temperature Coefficient of Input Forward Voltage	$\Delta V_F / \Delta T_A$		-1.3		mV/°C			
Input Reverse Breakdown Voltage	BV_R	5			V	$I_R = 10\ \mu\text{A}$		
Input Capacitance	C_{IN}		70		pF	$f = 1\text{ MHz}$, $V_F = 0\text{ V}$		

Table 6. Switching Specifications (AC)

Unless otherwise noted, all typical values at $T_A = 25^\circ\text{C}$, $V_{CC2} - V_{EE} = 30\text{ V}$, $V_E - V_{EE} = 0\text{ V}$;
all Minimum/Maximum specifications are at Recommended Operating Conditions.

Parameter	Symbol	Min.	Typ.	Max.	Units	Test Conditions	Fig.	Note
Propagation Delay Time to High Output Level	t_{PLH}	100	180	250	ns	$R_g = 20\ \Omega$, $C_g = 5\ \text{nF}$, $f = 10\ \text{kHz}$,	1, 10, 11, 12, 13, 26	13, 15
Propagation Delay Time to Low Output Level	t_{PHL}	100	180	250	ns	Duty Cycle = 50%, $I_F = 10\ \text{mA}$, $V_{CC2} = 30\ \text{V}$		
Pulse Width Distortion	PWD	-100	20	100	ns			14, 17
Propagation Delay Difference Between Any Two Parts or Channels	$(t_{PHL} - t_{PLH})$ PDD	-350		350	ns			17, 16
Rise Time	t_R		50		ns			
Fall Time	t_F		50		ns			
DESAT Sense to 90% VO Delay	$t_{DESAT(90\%)}$		0.15	0.3	μs	$C_{DESAT} = 100\ \text{pF}$, $R_F = 2.1\ \text{k}\Omega$, $R_g = 20\ \Omega$, $C_g = 5\ \text{nF}$, $V_{CC2} = 30\ \text{V}$	14, 27, 34	19
DESAT Sense to 10% VO Delay	$t_{DESAT(10\%)}$		1.1	1.5	μs	$C_{DESAT} = 100\ \text{pF}$, $R_F = 2.1\ \text{k}\Omega$, $R_g = 20\ \Omega$, $C_g = 5\ \text{nF}$, $V_{CC2} = 30\ \text{V}$	15, 16, 17, 27, 34	
DESAT Sense to Low Level FAULT Signal Delay	$t_{DESAT(FAULT)}$		0.25	0.5	μs	$C_{DESAT} = 100\ \text{pF}$, $R_F = 2.1\ \text{k}\Omega$, $R_g = 20\ \Omega$, $C_g = 5\ \text{nF}$, $V_{CC2} = 30\ \text{V}$	27, 34	18
DESAT Sense to DESAT Low Propagation Delay	$t_{DESAT(LOW)}$		0.25		μs	$C_{DESAT} = 100\ \text{pF}$, $R_F = 2.1\ \text{k}\Omega$, $R_g = 20\ \Omega$, $C_g = 5\ \text{nF}$, $V_{CC2} = 30\ \text{V}$	27, 34	19
DESAT Input Mute	$t_{DESAT(MUTE)}$	15	26	40	μs	$C_{DESAT} = 100\ \text{pF}$, $R_F = 2.1\ \text{k}\Omega$, $R_g = 20\ \Omega$, $C_g = 5\ \text{nF}$, $V_{CC1} = 5.5\ \text{V}$, $V_{CC2} = 30\ \text{V}$	34	20
Output High Level Common Mode Transient Immunity	$ CM_H $	15	25		$\text{kV}/\mu\text{s}$	$T_A = 25^\circ\text{C}$, $I_F = 10\ \text{mA}$ $V_{CM} = 1500\ \text{V}$, $V_{CC2} = 30\ \text{V}$	28, 29, 30, 31	21
Output Low Level Common Mode Transient Immunity	$ CM_L $	15	25		$\text{kV}/\mu\text{s}$	$T_A = 25^\circ\text{C}$, $V_F = 0\ \text{V}$ $V_{CM} = 1500\ \text{V}$, $V_{CC2} = 30\ \text{V}$	28, 29, 30, 31	22

Table 7. Package Characteristics

Parameter	Symbol	Min.	Typ.	Max.	Units	Test Conditions	Fig.	Note
Input-Output Momentary Withstand Voltage	V_{ISO}	3750			V_{rms}	RH < 50%, t = 1 min., $T_A = 25^\circ\text{C}$		6, 7
Input-Output Resistance	R_{I-O}		> 10 ⁹		Ω	$V_{I-O} = 500\text{ V}$		7
Input-Output Capacitance	C_{I-O}		1.3		pF	freq=1 MHz		
Output IC-to-Pins 9 & 10 Thermal Resistance	θ_{09-10}		30		$^\circ\text{C/W}$	$T_A = 25^\circ\text{C}$		

Notes:

- Derate linearly above 70°C free air temperature at a rate of 0.3 mA/°C.
- In order to achieve the absolute maximum power dissipation specified, pins 4, 9, and 10 require ground plane connections and may require airflow. See the Thermal Model section in the application notes at the end of this data sheet for details on how to estimate junction temperature and power dissipation. In most cases the absolute maximum output IC junction temperature is the limiting factor. The actual power dissipation achievable will depend on the application environment (PCB Layout, air flow, part placement, etc.). See the Recommended PCB Layout section in the application notes for layout considerations. Output IC power dissipation is derated linearly at 10 mW/°C above 90°C. Input IC power dissipation does not require derating.
- Maximum pulse width = 10 μs . This value is intended to allow for component tolerances for designs with IO peak minimum = 1.0 A. Derate linearly from 2.0 A at +25°C to 1.5 A at +105°C. This compensates for increased I_{OPEAK} due to changes in V_{OL} over temperature.
- This supply is optional. Required only when negative gate drive is implemented.
- Maximum pulse width = 50 μs .
- See the Slow IGBT Gate Discharge During Fault Condition section in the applications notes at the end of this data sheet for further details.
- 15 V is the recommended minimum operating positive supply voltage ($V_{CC2} - V_E$) to ensure adequate margin in excess of the maximum V_{UVLO+} threshold of 12.5 V. For High Level Output Voltage testing, V_{OH} is measured with a dc load current. When driving capacitive loads, V_{OH} will approach V_{CC} as I_{OH} approaches zero units.
- Maximum pulse width = 1.0 ms.
- Once V_O of the ACPL-330J is allowed to go high ($V_{CC2} - V_E > V_{UVLO}$), the DESAT detection feature of the ACPL-330J will be the primary source of IGBT protection. UVLO is needed to ensure DESAT is functional. Once $V_{UVLO+} > 12.5\text{ V}$, DESAT will remain functional until $V_{UVLO-} < 9.2\text{ V}$. Thus, the DESAT detection and UVLO features of the ACPL-330J work in conjunction to ensure constant IGBT protection.
- See the DESAT fault detection blanking time section in the applications notes at the end of this data sheet for further details.
- This is the “increasing” (i.e. turn-on or “positive going” direction) of $V_{CC2} - V_E$
- This is the “decreasing” (i.e. turn-off or “negative going” direction) of $V_{CC2} - V_E$
- This load condition approximates the gate load of a 1200 V/75A IGBT.
- Pulse Width Distortion (PWD) is defined as $|t_{PHL} - t_{PLH}|$ for any given unit.
- As measured from I_F to V_O .
- The difference between t_{PHL} and t_{PLH} between any two ACPL-330J parts under the same test conditions.
- As measured from ANODE, CATHODE of LED to V_{OUT}
- This is the amount of time from when the DESAT threshold is exceeded, until the FAULT output goes low.
- This is the amount of time the DESAT threshold must be exceeded before V_{OUT} begins to go low, and the FAULT output to go low. This is supply voltage dependent.
- Auto Reset: This is the amount of time when V_{OUT} will be asserted low after DESAT threshold is exceeded. See the Description of Operation (Auto Reset) topic in the application information section.
- Common mode transient immunity in the high state is the maximum tolerable dV_{CM}/dt of the common mode pulse, V_{CM} , to assure that the output will remain in the high state (i.e., $V_O > 15\text{ V}$ or $FAULT > 2\text{ V}$). A 100 pF and a 2.1 k Ω pull-up resistor is needed in fault detection mode.
- Common mode transient immunity in the low state is the maximum tolerable dV_{CM}/dt of the common mode pulse, V_{CM} , to assure that the output will remain in a low state (i.e., $V_O < 1.0\text{ V}$ or $FAULT < 0.8\text{ V}$).
- To clamp the output voltage at $V_{CC} - 3 V_{BE}$, a pull-down resistor between the output and V_{EE} is recommended to sink a static current of 650 μA while the output is high. See the Output Pull-Down Resistor section in the application notes at the end of this data sheet if an output pull-down resistor is not used.

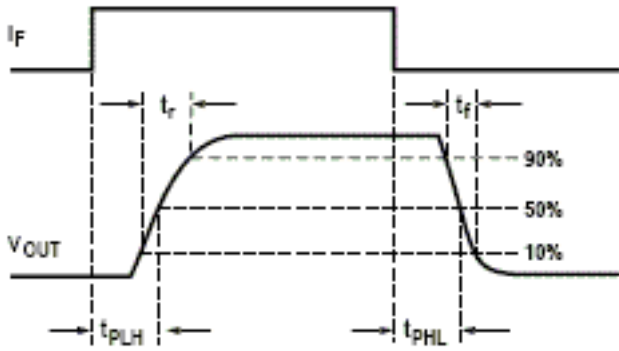

Figure 1. Timing Curve

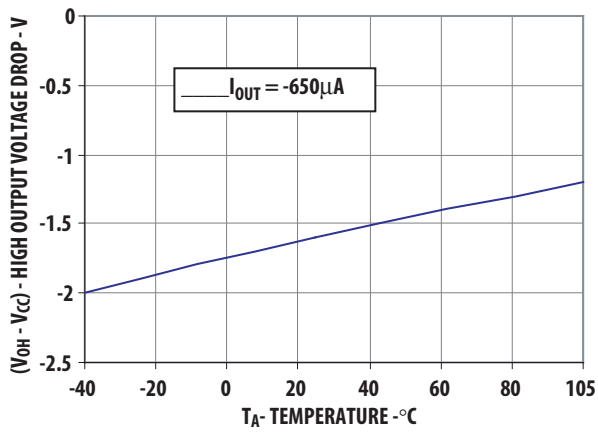

Figure 2. V_{OH} vs. temperature

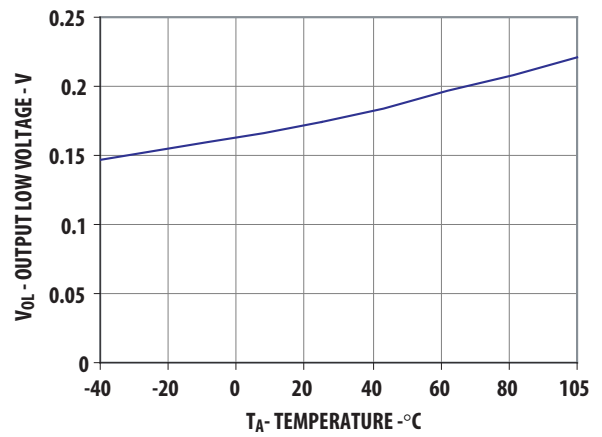

Figure 3. V_{OL} vs. temperature

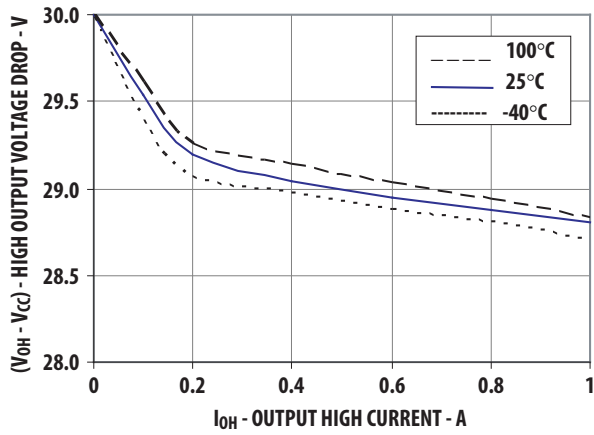

Figure 4. V_{OH} vs. I_{OH}

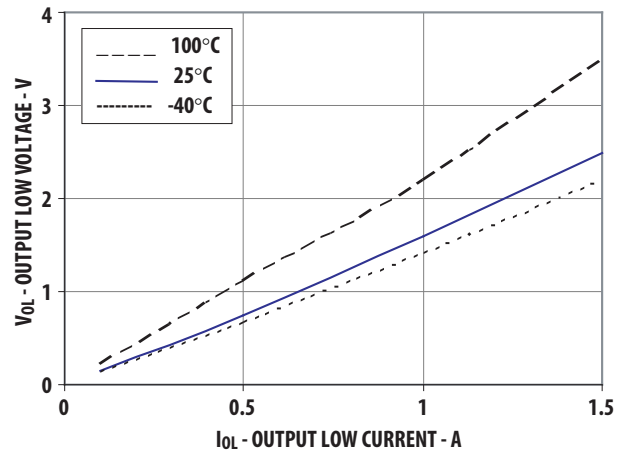

Figure 5. V_{OL} vs. I_{OL}

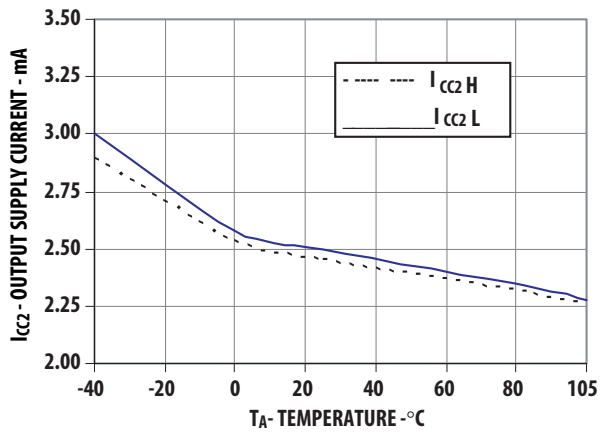

Figure 6. I_{CC2} vs. temperature

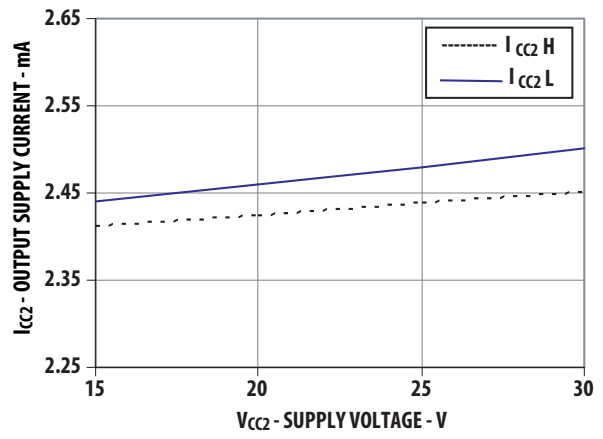

Figure 7. I_{CC2} vs. V_{CC2}

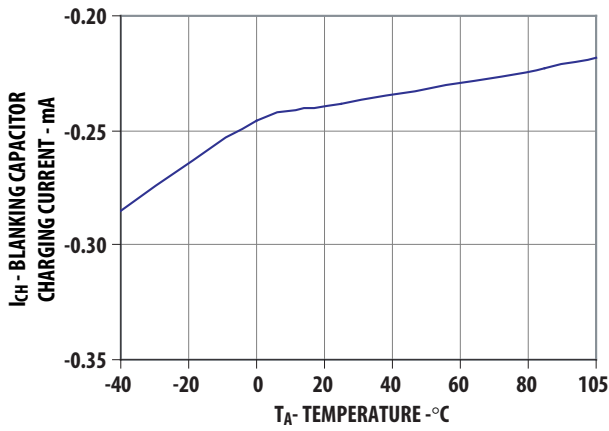

Figure 8. I_{CHG} vs. temperature

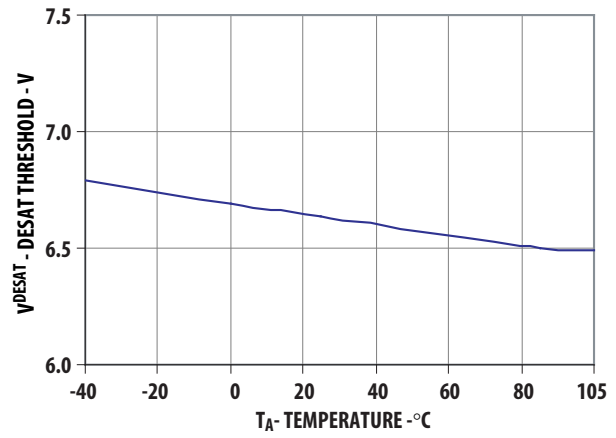

Figure 9. DESAT threshold vs. temperature

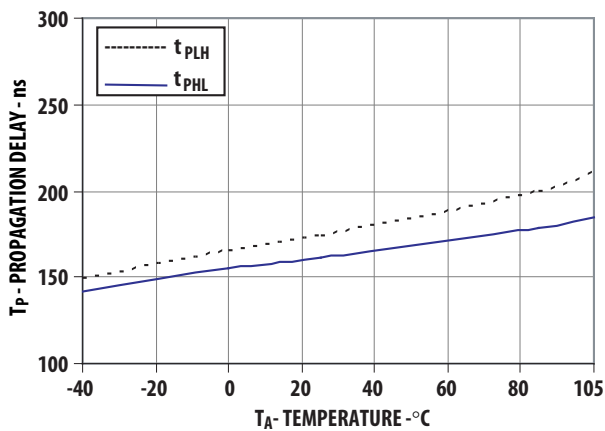

Figure 10. Propagation delay vs. temperature

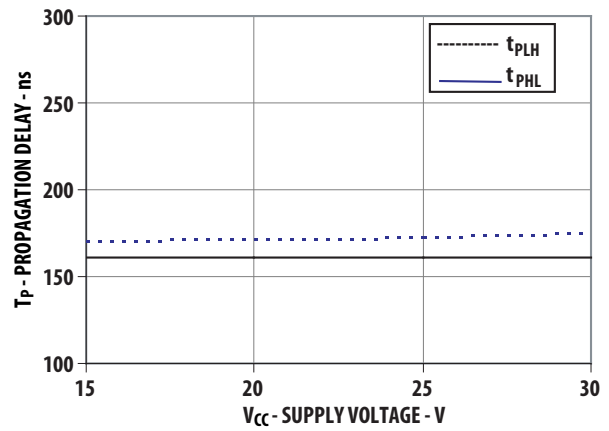

Figure 11. Propagation delay vs. supply voltage

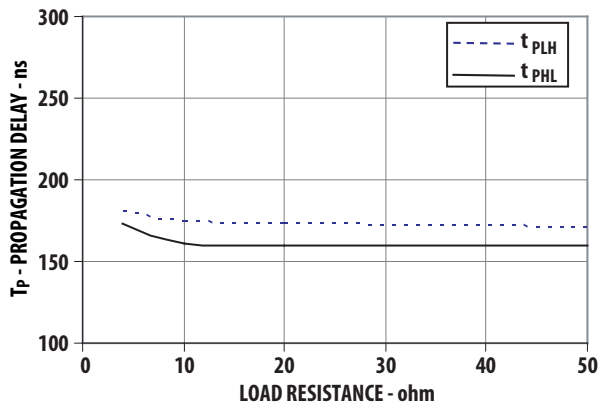

Figure 12. Propagation delay vs. load resistance

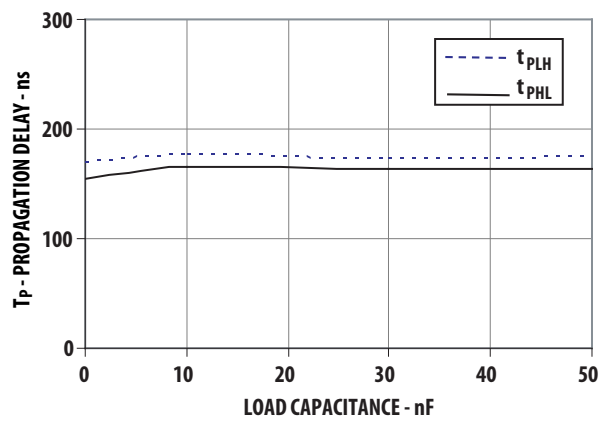

Figure 13. Propagation delay vs. load capacitance

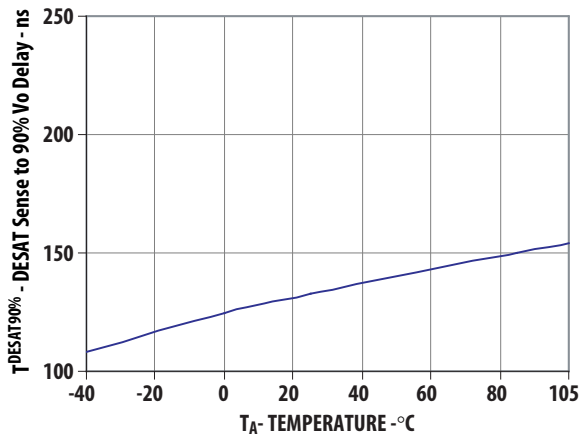

Figure 14. DESAT sense to 90% V_{OUT} delay vs. temperature

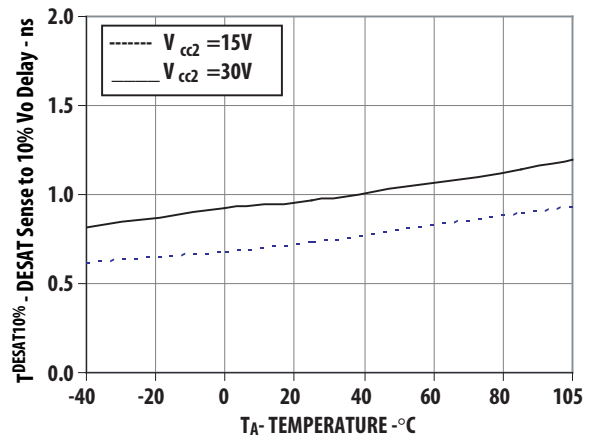

Figure 15. DESAT sense to 10% V_{OUT} delay vs. temperature

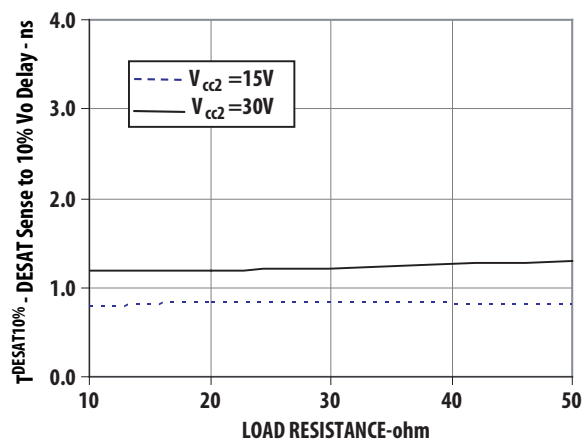

Figure 16. DESAT sense to 10% V_{OUT} delay vs. load resistance

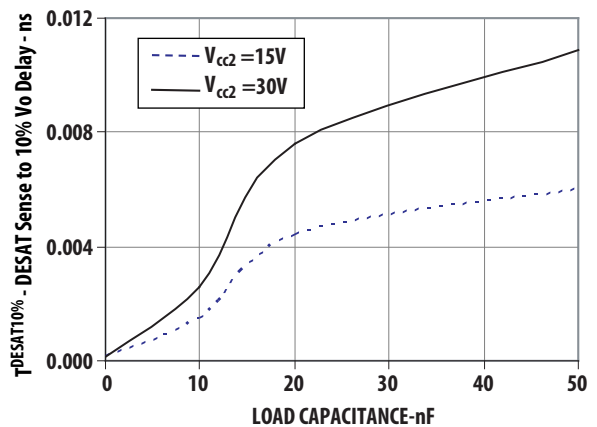

Figure 17. DESAT sense to 10% V_{OUT} delay vs. load capacitance

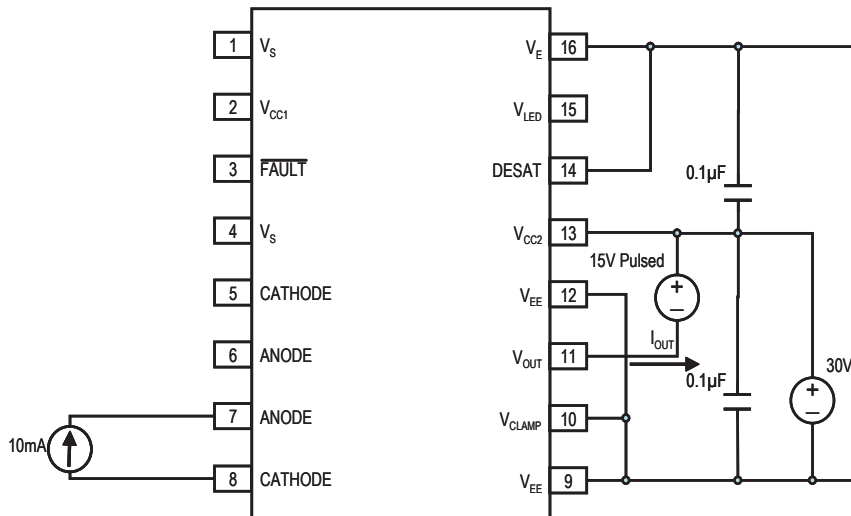

Figure 18. I_{OH} Pulsed test circuit

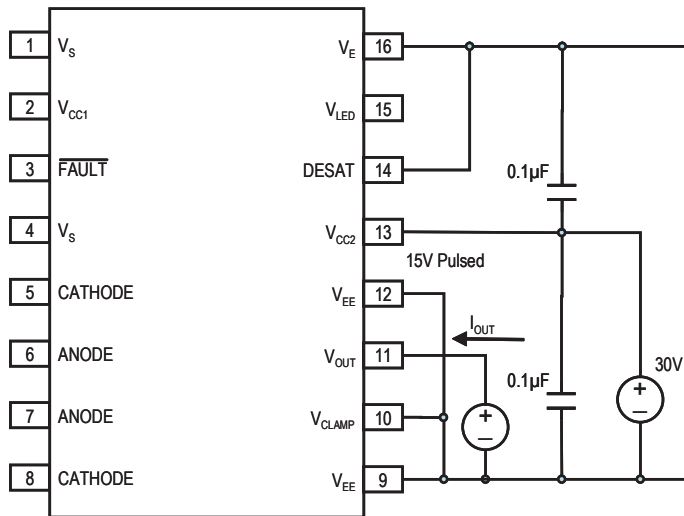

Figure 19. I_{OL} Pulsed test circuit

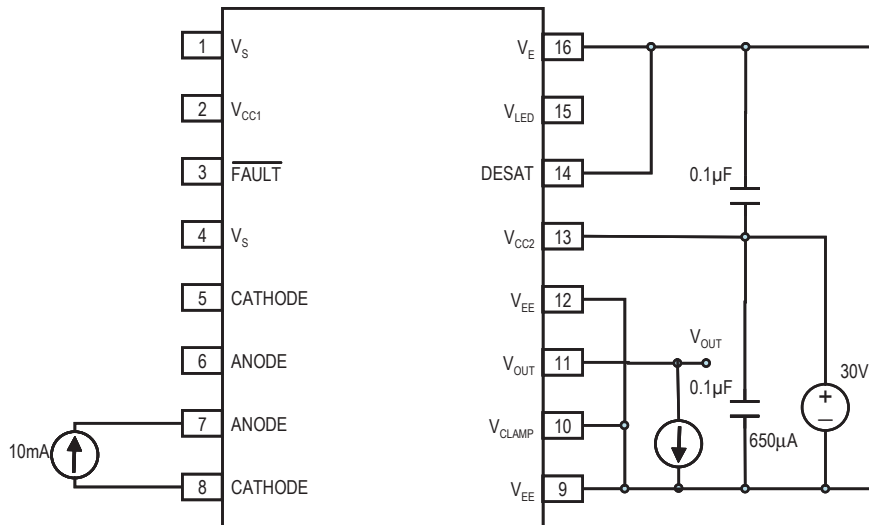

Figure 20. V_{OH} Pulsed test circuit

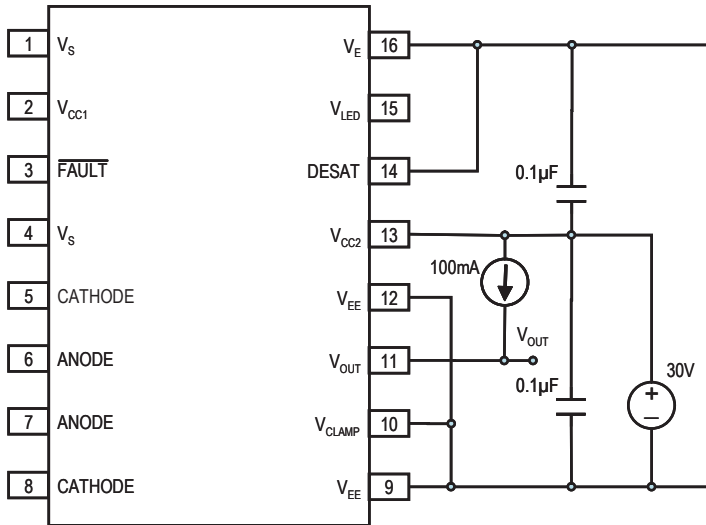

Figure 21. V_{OL} Pulsed test circuit

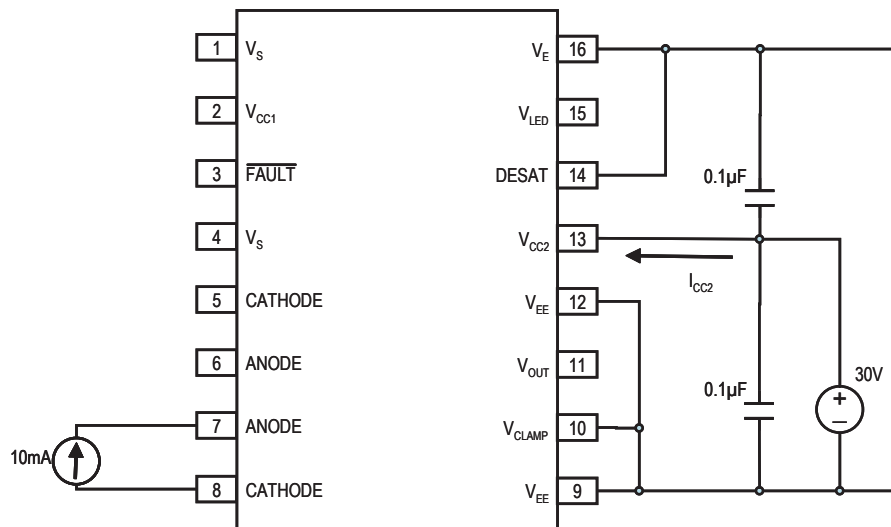

Figure 22. I_{CC2H} test circuit

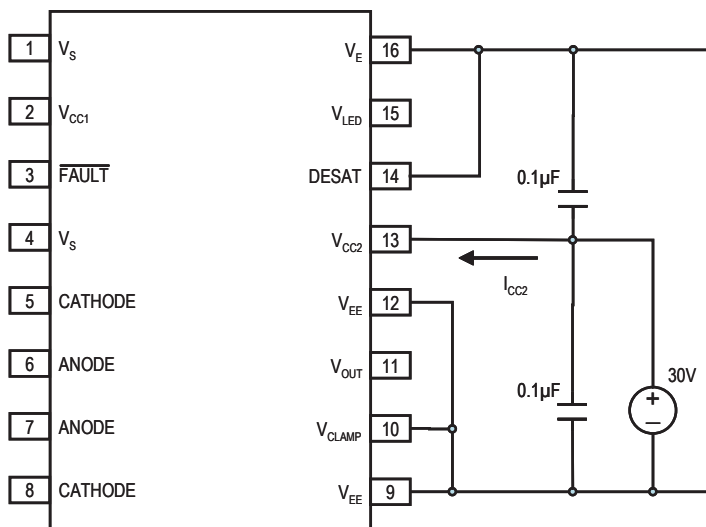

Figure 23. I_{CC2L} test circuit

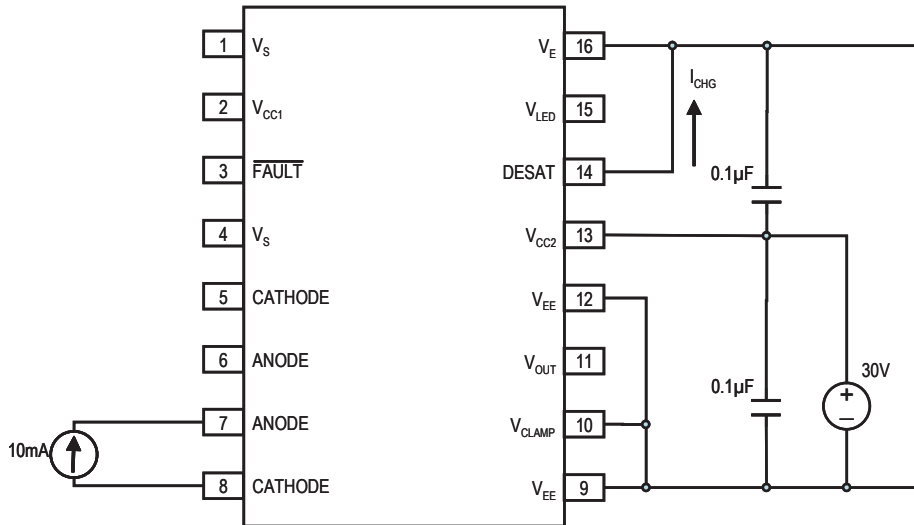

Figure 24. I_{CHG} Pulsed test circuit

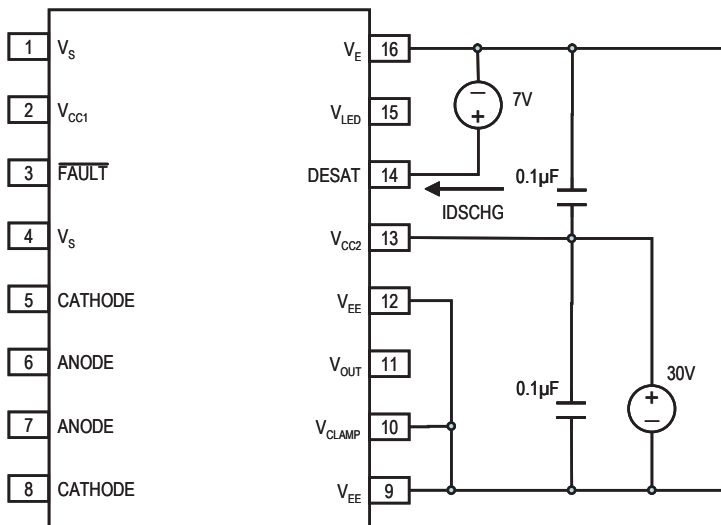

Figure 25. I_{DSCHG} test circuit

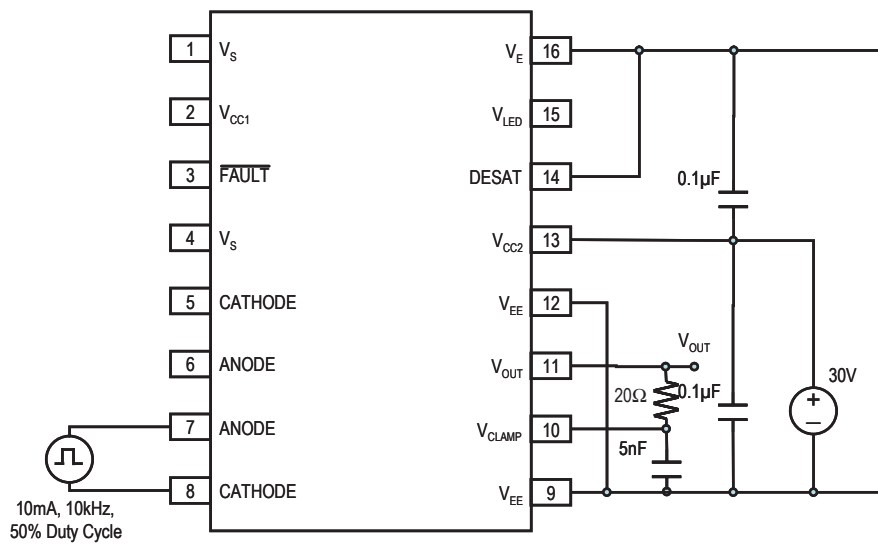

Figure 26. t_{PLH} , t_{PHL} , t_f , t_r test circuit

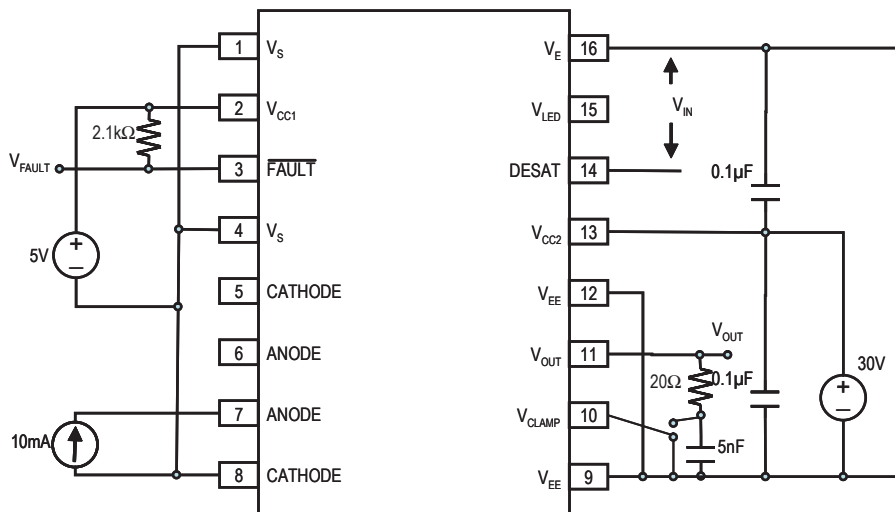

Figure 27. tDESAT fault test circuit

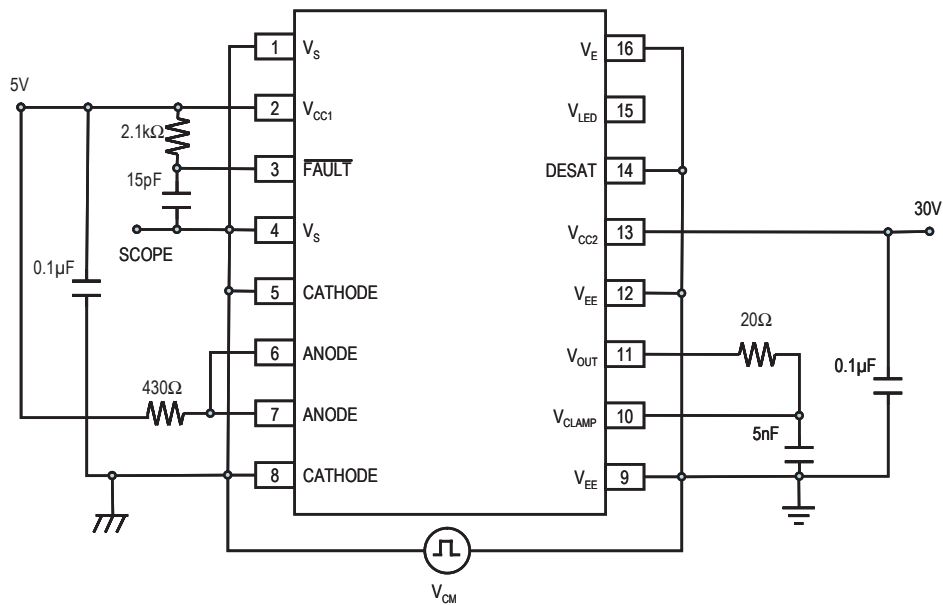

Figure 28. CMR Test circuit LED2 off

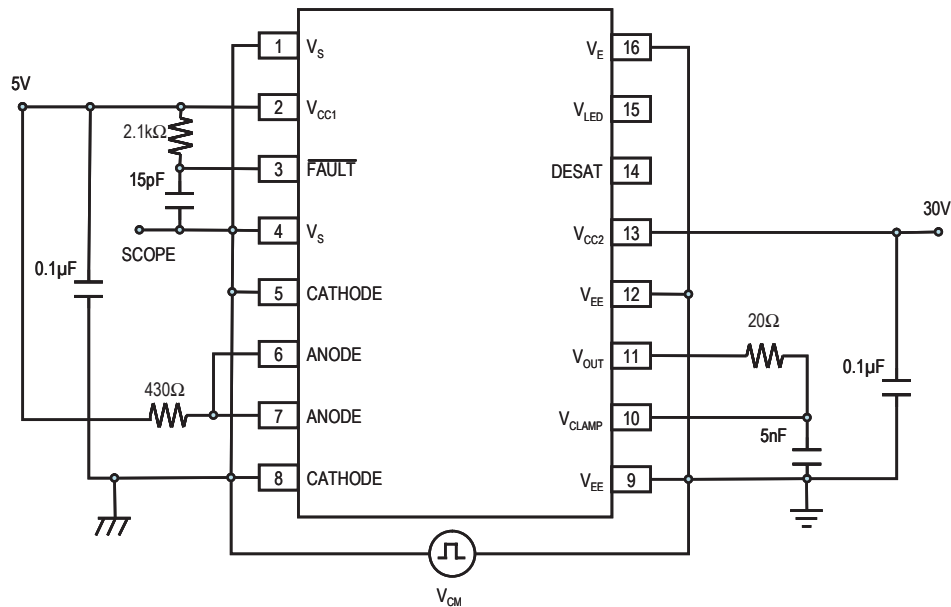

Figure 29. CMR Test Circuit LED2 on

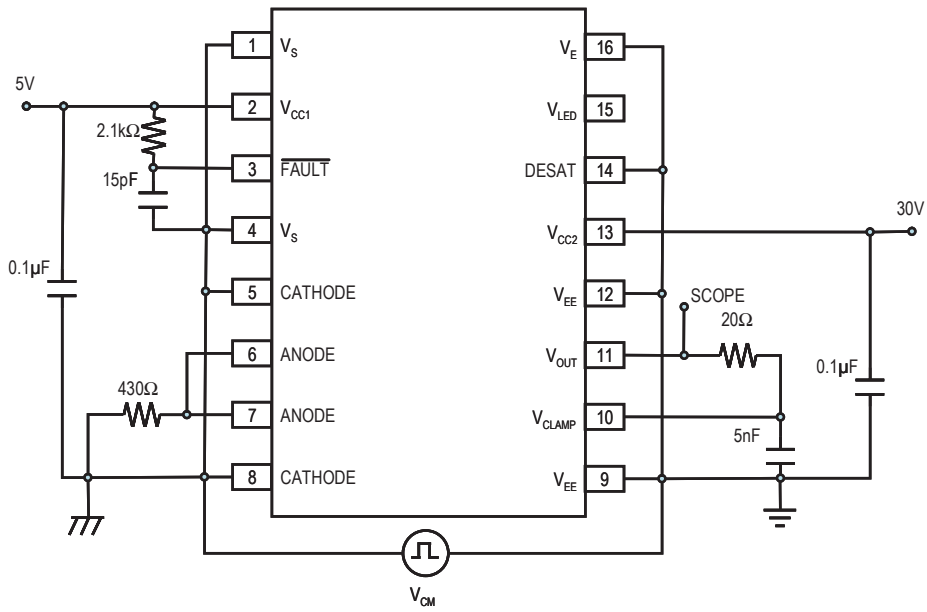

Figure 30. CMR Test circuit LED1 off

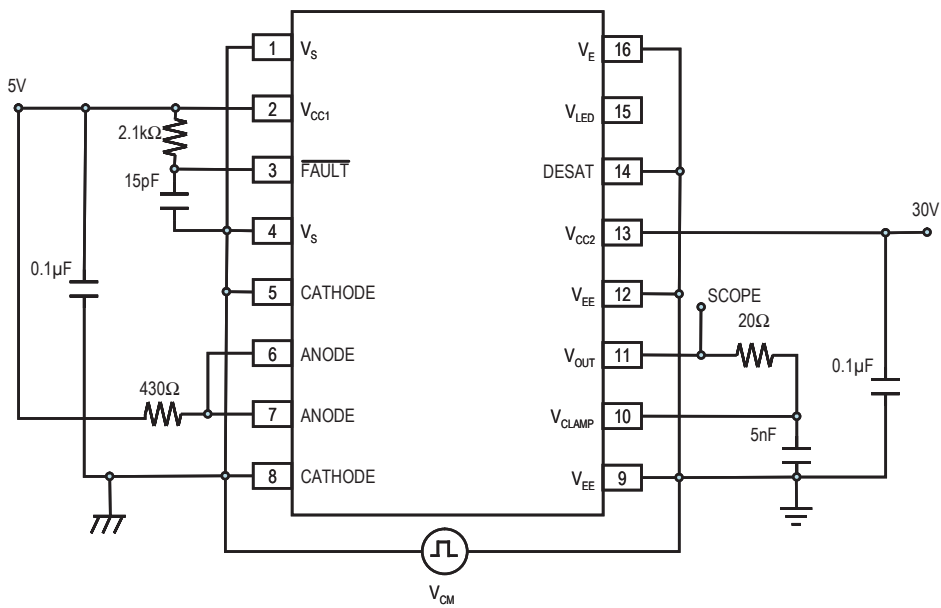

Figure 31. CMR Test Circuit LED1 on

Application Information

Product Overview Description

The ACPL-330J is a highly integrated power control device that incorporates all the necessary components for a complete, isolated IGBT / MOSFET gate drive circuit with fault protection and feedback into one SO-16 package. Active Miller clamp function eliminates the need of negative gate drive in most application and allows the use of simple bootstrap supply for high side driver. An optically isolated power output stage drives IGBTs with power ratings of up to 100 A and 1200 V. A high speed internal optical link minimizes the propagation delays between the microcontroller and the IGBT while allowing the two systems to operate at very large common mode voltage differences that are common in industrial motor drives and other power switching applications. An output IC provides local protection for the IGBT to prevent damage during over current, and a second optical link provides a fully isolated fault status feedback signal for the microcontroller. A built in “watchdog” circuit, UVLO monitors the power stage supply voltage to prevent IGBT caused by insufficient gate drive voltages. This integrated IGBT gate driver is designed to increase the performance and reliability of a motor drive without the cost, size, and complexity of a discrete design.

Two light emitting diodes and two integrated circuits housed in the same SO-16 package provide the input control circuitry, the output power stage, and two optical channels. The output Detector IC is designed manufactured on a high voltage BiCMOS/Power DMOS process. The forward optical signal path, as indicated by LED1, transmits the gate control signal. The return optical signal path, as indicated by LED2, transmits the fault status feedback signal.

Under normal operation, the LED1 directly controls the IGBT gate through the isolated output detector IC, and LED2 remains off. When an IGBT fault is detected, the output detector IC immediately begins a “soft” shutdown sequence, reducing the IGBT current to zero in a controlled manner to avoid potential IGBT damage from inductive over voltages. Simultaneously, this fault status is transmitted back to the input via LED2, where the fault latch disables the gate control input and the active low fault output alerts the microcontroller.

During power-up, the Under Voltage Lockout (UVLO) feature prevents the application of insufficient gate voltage to the IGBT, by forcing the ACPL-330J’s output low. Once the output is in the high state, the DESAT (V_{CE}) detection feature of the ACPL-330J provides IGBT protection. Thus, UVLO and DESAT work in conjunction to provide constant IGBT protection.

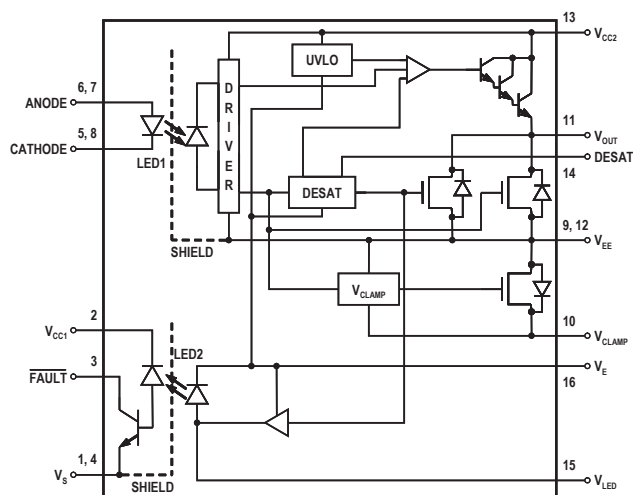

Figure 32. Block Diagram of ACPL-330J

Recommended Application Circuit

The ACPL-330J has an LED input gate control, and an open collector fault output suitable for wired ‘OR’ applications. The recommended application circuit shown in Figure 33 illustrates a typical gate drive implementation using the ACPL-330J. The following describes about driving IGBT. However, it is also applicable to MOSFET. Depending upon the MOSFET or IGBT gate threshold requirements, designers may want to adjust the V_{CC} supply voltage (Recommended V_{CC} = 17.5V for IGBT and 12.5V for MOSFET).

The two supply bypass capacitors (0.1 μ F) provide the large transient currents necessary during a switching transition. Because of the transient nature of the charging currents, a low current (5mA) power supply suffices. The desaturation diode D_{DESAT} 600V/1200V fast recovery type, t_{rr} below 75ns (e.g. ERA34-10) and capacitor C_{BLANK} are necessary external components for the fault detection circuitry. The gate resistor R_G serves to limit gate charge current and controls the IGBT collector voltage rise and fall times. The open collector fault output has a passive pull-up resistor R_F (2.1 k Ω) and a 330 pF filtering capacitor, C_F. A 47 k Ω pull down resistor R_{PULL-DOWN} on V_{OUT} provides a predictable high level output voltage (V_{OH}). In this application, the IGBT gate driver will shut down when a fault is detected and fault reset by next cycle of IGBT turn on. Application notes are mentioned at the end of this datasheet.

Output Control

The outputs (V_{OUT} and FAULT) of the ACPL-330J are controlled by the combination of I_F , UVLO and a detected IGBT Desat condition. Once UVLO is not active ($V_{CC2} - V_E > V_{UVLO}$), V_{OUT} is allowed to go high, and the DESAT (pin 14) detection feature of the ACPL-330J will be the primary source of IGBT protection. UVLO is needed to ensure DESAT is functional. Once $V_{UVLO+} > 10.5V$, DESAT will remain functional until $V_{UVLO-} < 11.1V$. Thus, the DESAT detection and UVLO features of the ACPL-330J work in conjunction to ensure constant IGBT protection.

Desaturation Detection and High Current Protection

The ACPL-330J satisfies these criteria by combining a high speed, high output current driver, high voltage optical isolation between the input and output, local IGBT desaturation detection and shut down, and an optically isolated fault status feedback signal into a single 16-pin surface mount package.

The fault detection method, which is adopted in the ACPL-330J is to monitor the saturation (collector) voltage of the IGBT and to trigger a local fault shutdown sequence if the collector voltage exceeds a predetermined threshold. A small gate discharge device slowly reduces the high short circuit IGBT current to prevent damaging voltage spikes. Before the dissipated energy can reach destructive levels, the IGBT is shut off. During the off state of the IGBT, the fault detect circuitry is simply disabled to prevent false 'fault' signals.

The alternative protection scheme of measuring IGBT current to prevent desaturation is effective if the short circuit capability of the power device is known, but this method will fail if the gate drive voltage decreases enough to only partially turn on the IGBT. By directly measuring the collector voltage, the ACPL-330J limits the power dissipation in the IGBT even with insufficient gate drive voltage. Another more subtle advantage of the desaturation detection method is that power dissipation in the IGBT is monitored, while the current sense method relies on a preset current threshold to predict the safe limit of operation. Therefore, an overly conservative over current threshold is not needed to protect the IGBT.

Slow IGBT Gate Discharge during Fault Condition

When a desaturation fault is detected, a weak pull-down device in the ACPL-330J output drive stage will turn on to 'softly' turn off the IGBT. This device slowly discharges the IGBT gate to prevent fast changes in drain current that could cause damaging voltage spikes due to lead and wire inductance. During the slow turn off, the large output pull-down device remains off until the output voltage falls below $V_{EE} + 2$ Volts, at which time the large pull down device clamps the IGBT gate to V_{EE} .

DESAT Fault Detection Blanking Time

The DESAT fault detection circuitry must remain disabled for a short time period following the turn-on of the IGBT to allow the collector voltage to fall below the DESAT threshold. This time period, called the DESAT blanking time is controlled by the internal DESAT charge current, the DESAT voltage threshold, and the external DESAT capacitor.

The nominal blanking time is calculated in terms of external capacitance (C_{BLANK}), FAULT threshold voltage (V_{DESAT}), and DESAT charge current (I_{CHG}) as $t_{BLANK} = C_{BLANK} \times V_{DESAT} / I_{CHG}$. The nominal blanking time with the recommended 100pF capacitor is $100pF * 6.5 V / 240 \mu A = 2.7 \mu sec$.

The capacitance value can be scaled slightly to adjust the blanking time, though a value smaller than 100 pF is not recommended. This nominal blanking time represents the longest time it will take for the ACPL-330J to respond to a DESAT fault condition. If the IGBT is turned on while the collector and emitter are shorted to the supply rails (switching into a short), the soft shut-down sequence will begin after approximately 3 μsec . If the IGBT collector and emitter are shorted to the supply rails after the IGBT is already on, the response time will be much quicker due to the parasitic parallel capacitance of the DESAT diode. The recommended 100pF capacitor should provide adequate blanking as well as fault response times for most applications.

I_F	UVLO ($V_{CC2} - V_E$)	Desat Condition Detected on Pin 14	Pin 3 (FAULT) Output	V_{OUT}
X	Active	X	X	Low
X	X	Yes	Low	Low
OFF	X	X	X	Low
ON	Not Active	No	High	High

Under Voltage Lockout

The ACPL-330J Under Voltage Lockout (UVLO) feature is designed to prevent the application of insufficient gate voltage to the IGBT by forcing the ACPL-330J output low during power-up. IGBTs typically require gate voltages of 15 V to achieve their rated $V_{CE(ON)}$ voltage. At gate voltages below 13 V typically, the $V_{CE(ON)}$ voltage increases dramatically, especially at higher currents. At very low gate voltages (below 10 V), the IGBT may operate in the linear region and quickly overheat. The UVLO function causes the output to be clamped whenever insufficient operating supply (V_{CC2}) is applied. Once V_{CC2} exceeds V_{UVLO+} (the positive-going UVLO threshold), the UVLO clamp is released to allow the device output to turn on in response to input signals. As V_{CC2} is increased from 0 V (at some level below V_{UVLO+}), first the DESAT protection circuitry becomes active. As V_{CC2} is further increased (above V_{UVLO+}), the UVLO clamp is released. Before the time the UVLO clamp is released, the DESAT protection is already active. Therefore, the UVLO and DESAT Fault detection feature work together to provide seamless protection regardless of supply voltage (V_{CC2}).

Active Miller Clamp

A Miller clamp allows the control of the Miller current during a high dV/dt situation and can eliminate the use of a negative supply voltage in most of the applications. During turn-off, the gate voltage is monitored and the clamp output is activated when gate voltage goes below 2V (relative to V_{EE}). The clamp voltage is $V_{OL}+2.5V$ typ for a Miller current up to 1100mA. The clamp is disabled when the LED input is triggered again.

Other Recommended Components

The application circuit in Figure 33 includes an output pull-down resistor, a DESAT pin protection resistor, a FAULT pin capacitor, and a FAULT pin pullup resistor and Active Miller Clamp connection.

Output Pull-Down Resistor

During the output high transition, the output voltage rapidly rises to within 3 diode drops of V_{CC2} . If the output current then drops to zero due to a capacitive load, the output voltage will slowly rise from roughly $V_{CC2}-3(V_{BE})$ to V_{CC2} within a period of several microseconds. To limit the output voltage to $V_{CC2}-3(V_{BE})$, a pull-down resistor, $R_{PULL-DOWN}$ between the output and V_{EE} is recommended to sink a static current of several 650 μA while the output is high. Pull-down resistor values are dependent on the amount of positive supply and can be adjusted according to the formula, $R_{pull-down} = [V_{CC2}-3 * (V_{BE})] / 650 \mu A$.

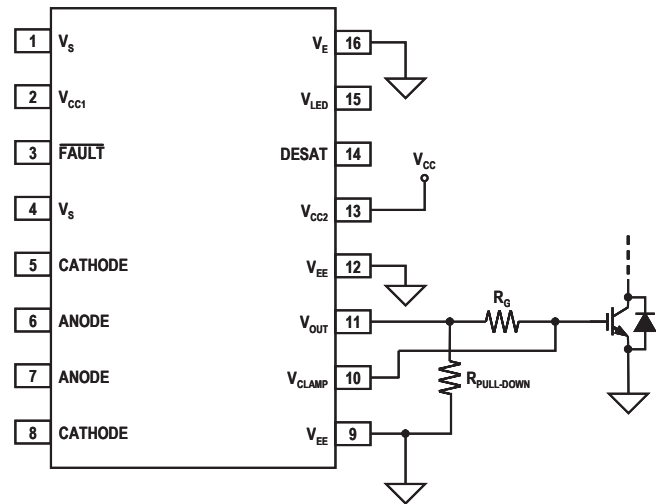

Figure 35. Output pull-down resistor.

DESAT Pin Protection Resistor

The freewheeling of flyback diodes connected across the IGBTs can have large instantaneous forward voltage transients which greatly exceed the nominal forward voltage of the diode. This may result in a large negative voltage spike on the DESAT pin which will draw substantial current out of the driver if protection is not used. To limit this current to levels that will not damage the driver IC, a 100 ohm resistor should be inserted in series with the DESAT diode. The added resistance will not alter the DESAT threshold or the DESAT blanking time.

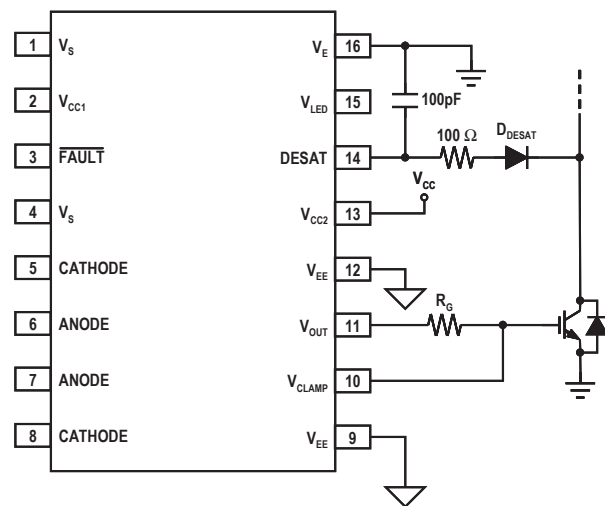

Figure 36. DESAT pin protection.

Capacitor on FAULT Pin for High CMR

Rapid common mode transients can affect the fault pin voltage while the fault output is in the high state. A 330 pF capacitor should be connected between the fault pin and ground to achieve adequate CMOS noise margins at the specified CMR value of 15 kV/ μ s. The added capacitance does not increase the fault output delay when a desaturation condition is detected.

Pull-up Resistor on FAULT Pin

The FAULT pin is an open collector output and therefore requires a pull-up resistor to provide a high-level signal. Also the FAULT output can be wire 'OR'ed together with other types of protection (e.g. over-temperature, over-voltage, over-current) to alert the microcontroller.

Other Possible Application Circuit (Output Stage)

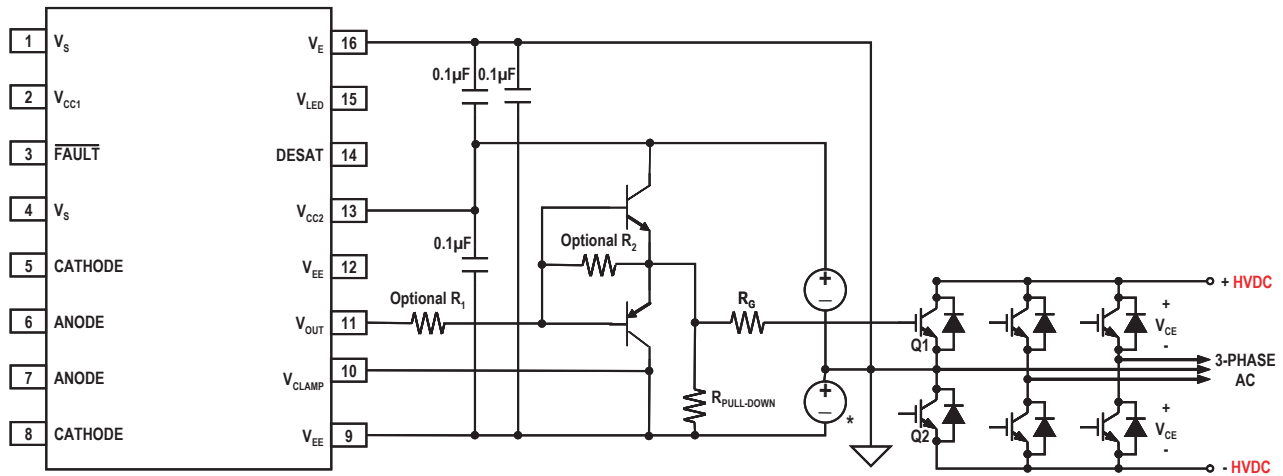

Figure 37. IGBT drive with negative gate drive, external booster and desaturation detection (V_{CLAMP} should be connected to V_{EE} when it is not used) V_{CLAMP} is used as secondary gate discharge path. * indicates component required for negative gate drive topology

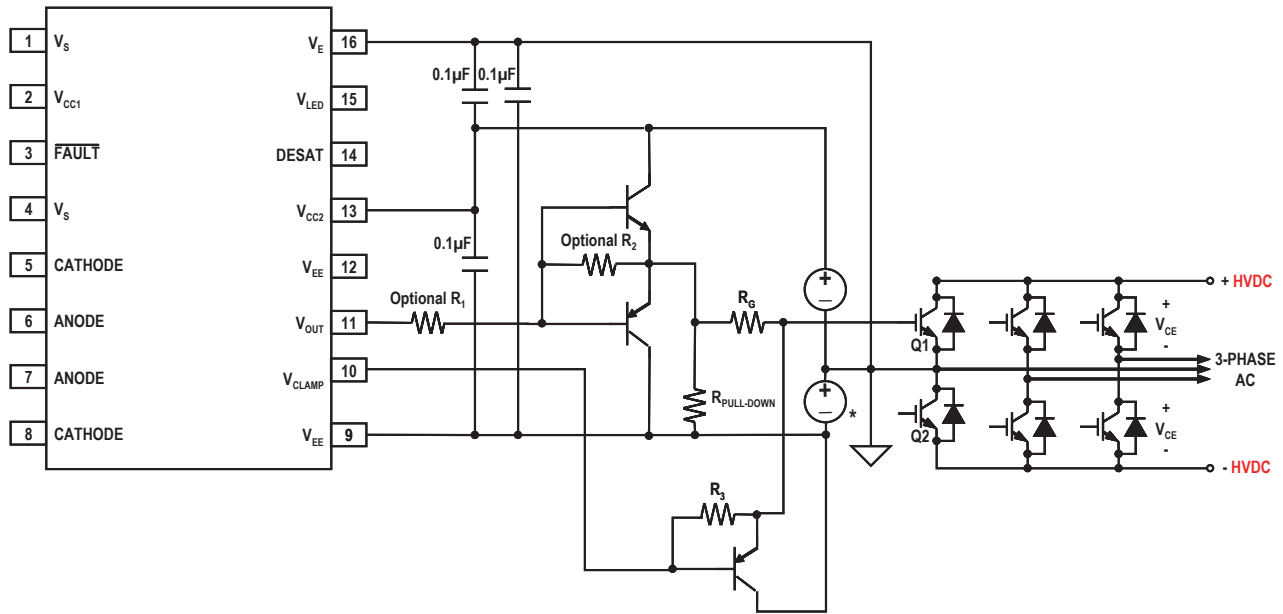

Figure 38. Large IGBT drive with negative gate drive, external booster. V_{CLAMP} control secondary discharge path for higher power application.

Related Application Notes

AN5314 – Active Miller Clamp

AN5315 – “Soft” Turn-off Feature

AN1087 – Thermal Data for Optocouplers

AN1043 – Common-Mode Noise : Sources and Solutions

AV02-0310EN - Plastic Optocouplers Product ESD and Moisture Sensitivity

For product information and a complete list of distributors, please go to our web site: www.avagotech.com

Avago, Avago Technologies, and the A logo are trademarks of Avago Technologies in the United States and other countries.
Data subject to change. Copyright © 2005-2009 Avago Technologies. All rights reserved.
AV02-1280EN - April 24, 2009

