

IRC urinal flush control valve

installation guide



1 Introduction

the infrared urinal flush control (IRC) valve automatically manages the supply of water to a urinal cistern.

On detection of movement in the washroom, the IRC activates a 30 minute cycle allowing water to flow into the cistern. During the last five minutes of the 30 minute cycle the sensor 'looks' for movement. If no movement is detected during these five

minutes the valve will close. If, however, the sensor does detect movement a new 30 minute cycle is activated. If no movement is detected for 12 hours the IRC will activate a hygiene cycle.

3 YEAR
warranty*

*See page 13 for details



supplied parts

- 1 Sensor unit
- 2 Valve unit
- 3 Remote valve plug and gasket
- 4 Flush mount plate
- 5 Terminal cover
- 6 Mounting bracket
- 7 Screws
- 8 Clip nut
- 9 White blanking plug
- 10 3mm selectable valve seat
- 11 Screw cap

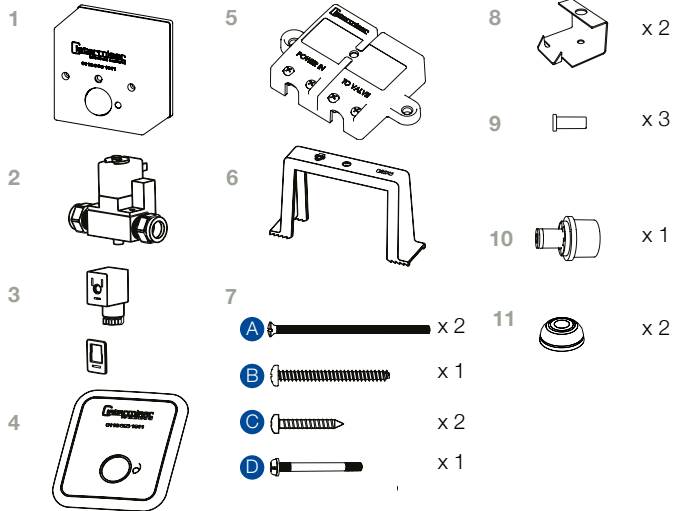

not supplied

- 2-core low voltage cable for remotely installed applications.
- Pattern box for surface / wall mounted applications.

FIT IN ACCORDANCE WITH WATER REGULATIONS

Under the water regulations, urinals should use no more than 7.5 litres per bowl per hour (10 litres for a single bowl)

2 Positioning

NOTE:

One IRC is required for every cistern.

NOTE: Where one cistern feeds multiple urinal outlets, ensure the urinal outlets are evenly distributed and balanced so the cistern gives equal flush.

A

pipe mounted, on the solenoid
(Battery powered only)

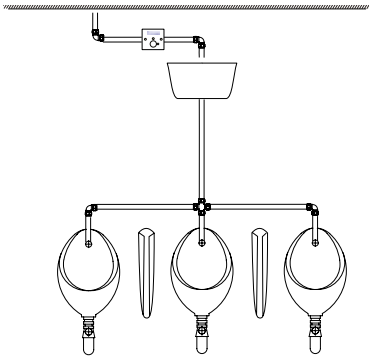

B

wall mounted, remote from the solenoid
(Battery and/or mains electricity)

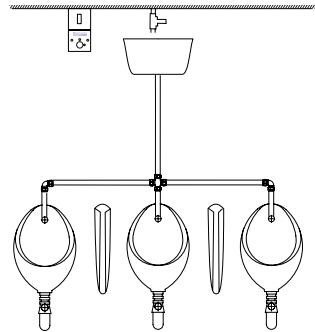

C

ceiling mounted, remote from solenoid (Battery and/or mains electricity)

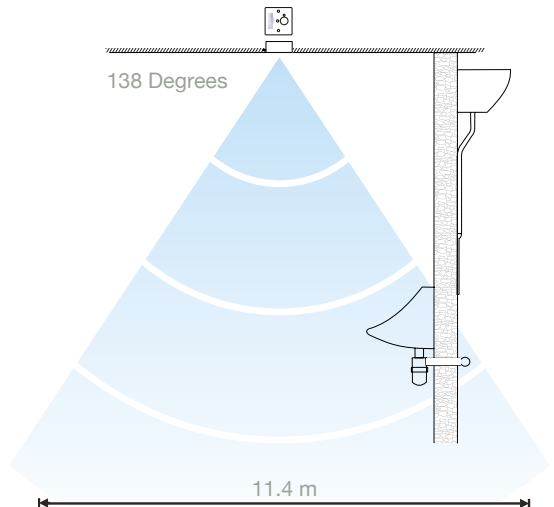
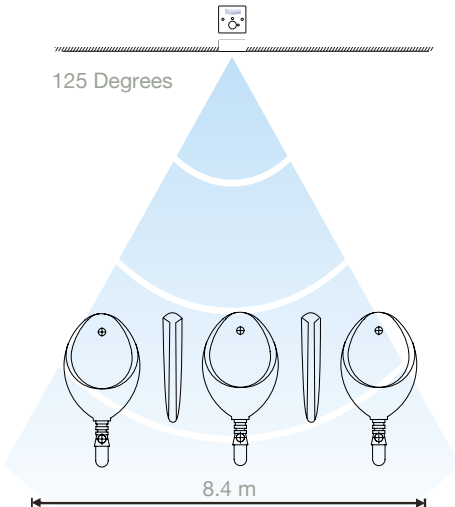

3 Valve installation

Install the valve on the 15mm pipe feeding the cistern.

NOTE:

The valve should be positioned with the directional arrow pointing in the same direction as the flow of the water with the solenoid on top.

NOTE:

There should be no restriction, such as a petcock or bibtap, after the valve.

To change the direction of the valve remove the screws from the black valve body, turn the valve around and screw the valve back in.

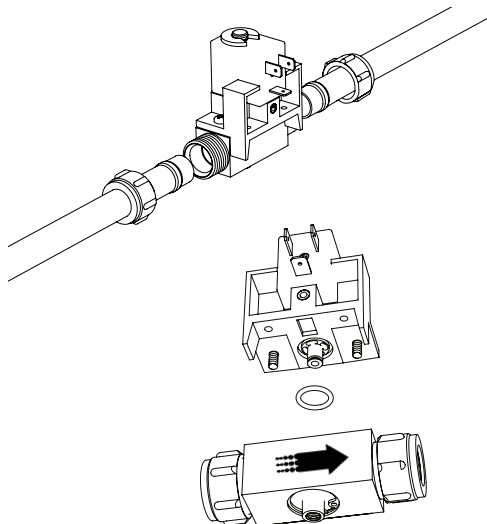

changing the selectable valve seat

NOTE:

3mm orifice should only be fitted when the water supply is from a tank or is at low pressure. (Refer to chart below)

1. To change the valve seat, remove the screws from the solenoid housing; this will give access to the selectable valve seat.
2. Remove the selectable valve seat from the valve body.
3. When refitting, place the selectable valve seat into the solenoid housing and fit the solenoid housing back on to the valve body.

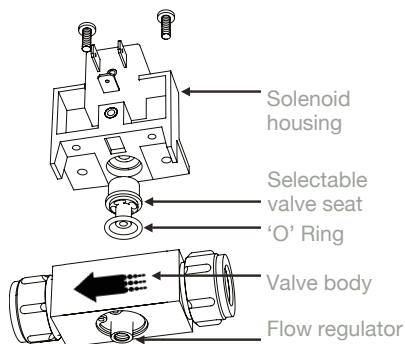

Valve seat	Dynamic Pressure	Max Flow lpm	Min Flow lpm
1.5mm orifice insert	6 bar	2.7	0.03
1.5mm orifice insert	2 bar	1.6	0.01
3mm orifice insert	2 bar	3.0	0.05
3mm orifice insert	0.1 bar	0.9	No flow

4 Sensor installation

A pipe mounted – battery powered only

Insert the batteries into the battery compartment of the sensor unit. Fit the sensor on to the solenoid and secure using screw **A**. Use the white blanking plugs **9** to fill in the unused holes.

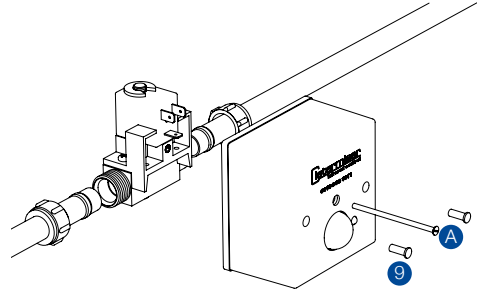

B wall mounted or solid ceiling, remote from solenoid – mains and/or battery powered

Using a subsurface or surface mounted pattress box, wire the sensor unit to the solenoid ensuring that the '1' on the sensor is connected to the '1' on the remote valve plug and likewise the '2' should be connected to '2'.

(See **E** on page 7)

For battery powered installations, insert the batteries into the battery compartment. For mains powered installations, wire the sensor unit using the appropriate mains voltage cable.

Fit terminal cover **5** to the sensor unit.

Insert the sensor unit and using two screws **A** secure it to the pattress box.

NOTE: If the wiring is not connected '1' to '1' and '2' to '2' the polarity will be reversed and the valve will not function as intended.

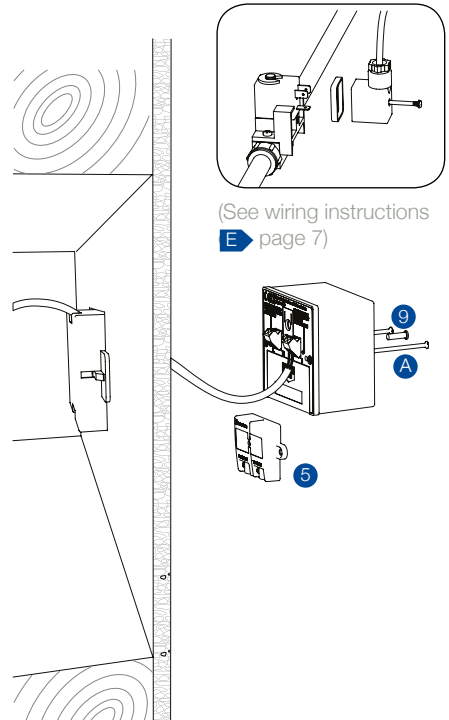

C

flush mounted, ceiling tile installations remote from solenoid – mains and/or battery powered

1. Using the template supplied, cut a hole for the sensor in the ceiling.
2. Wire the valve as indicated in **E**.
3. Position the flush mount plate **4** and screw the terminal cover **5** to the back of the sensor unit. (This will secure the flush mount plate).
4. Place the mounting bracket **6** over the back of the sensor unit and secure using screw **B**.

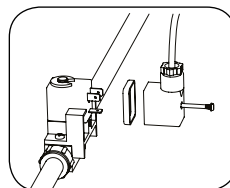
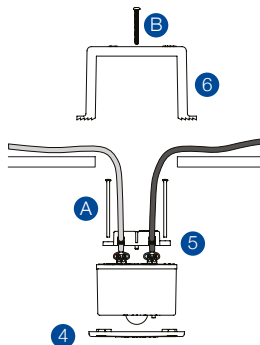

(See wiring instructions **E** page 7)

D

plaster board installation

Install as indicated in section **B**

1. Follow instructions **C** 1-3
2. Fit clip nuts **8** on plaster board
3. Punch holes in the flush plate and secure using screw **C**
4. Fit screw caps **11**

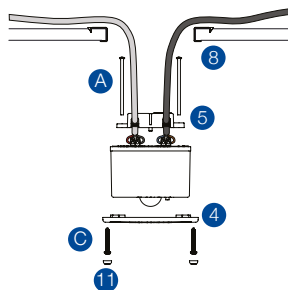

E wiring the valve for remote sensor installation

Using low voltage 2-core cable, wire the remote valve plug and gasket taking note of the '1' and '2' number markings. You will need to match these numbers when wiring the sensor i.e. '1' to '1' and '2' to '2'.

Place the plug on the solenoid and secure in place with screw **D**.

NOTE: Cable Specification:

CSA = 1mm²

Length = 10m (Max.) from sensor to solenoid

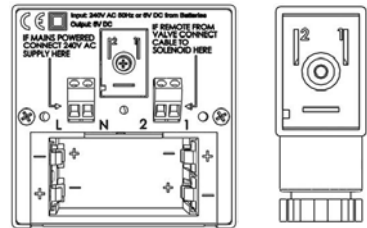
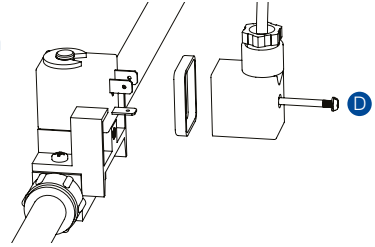

5 Commissioning

Once all is installed, the flow rate will need to be adjusted to suit the particular installation.

Using the flow regulator on the bottom of the solenoid you can either increase or decrease the flow of water. Ideally the cistern should flush once every 30 minutes.

Adjust the valve by turning the screw at the base of the brass valve body clockwise to reduce the flow and anti-clockwise to increase the flow.

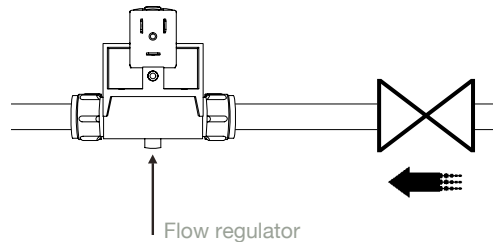

Flow regulator

NOTE: Use the table below to set your cistern to flush once every 30 minutes. Adjust the flow through the valve so it takes the time below to fill a measuring cup to 100ml.

Cistern size	Time to fill 100ml
4.5L	40 sec
9.0L	20 sec
13.5L	13.5 sec

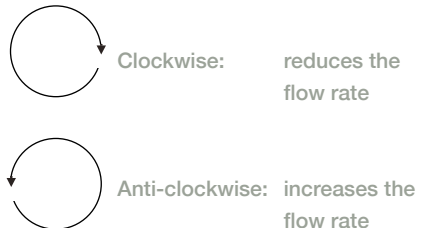

6 Self-test mode

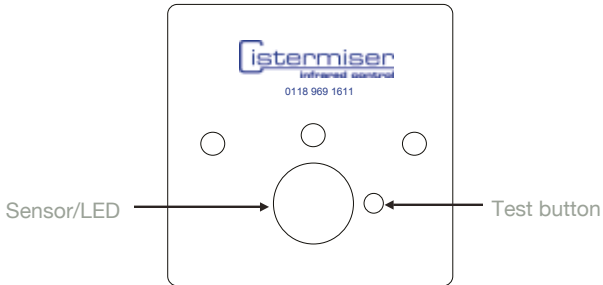

- 1 Press Test Button (Amber LED will illuminate).



2 Test cycle

Valve Test Mode

Valve opens and closes five times - amber LED will blink with every valve movement.



Sensor Test Mode

Valve closed for one minute. Body movement causes the amber LED to flash when detected. Check detection range by walking around the room to confirm the light flashing.



After one minute the sensor test mode will finish and the sensor will revert to normal operation.

Normal operation

Valve remains open for a period of 30 minutes (green LED will flash) after which it will shut down. If, however, presence is detected within the last five minutes of the 30 minute cycle, the valve will reactivate a new cycle.

LED sequence

Valve open	green LED flash once every 3 seconds (battery) green LED flash once every 2 seconds (mains)
Low Power	red LED flash
Fault	double red LED flash
Start up / test cycle	amber LED

7 Power connection

Cistermiser IRC can be powered by either batteries or mains electricity.

Fitting batteries to a mains connected unit will offer back-up power in case of mains supply failure.

NOTE: When fitted directly onto pipework only use battery power pack.

8 Usage advice and specification

power

Mains Supply:	Nominal 230V 50Hz 20mA.
Battery Supply:	230V AC +/-10% 20mA nominal, 50mA max.
Batteries (recommended):	Duracell Plus (Gold Top) MN1500 Capacity 2700mAh.
Operating Life:	Up to three years with recommended batteries depending on washroom usage.

solenoid valve

6V Latching Valve:	UK WRAS approved. One valve per sensor unit.
--------------------	--

pressure range

0.1 - 6.0 bar (Covered by selectable valve seat). Integral slow fill flow regulator.
If supply pressure is above 6.0 bar, fit a pressure reducing valve.

9 Frequently asked questions

test mode does not function

No power	Ensure unit is powered. Change batteries if battery powered; ensure mains electrical power is functioning if mains powered.
Power supply fault	Disconnect one source of power and check by pushing the test button. When the sensor is mounted directly on the valve it should be battery powered ONLY. Also check remote wiring if sensor is remote from valve.

no water passing the valve

Water supply	Ensure water supply is turned on and reaching the valve. The valve comes with a factory fitted 1.5mm insert fitted for water pressures of 2 - 6 bar. If your water pressure is within this range and the optional 3mm insert has been fitted then revert back to the 1.5mm insert. The 3mm insert is for use with water pressures of 0.1 - 2 bar.
Blockage on the outlet pipe	If a petcock or bibtap has been fitted, ensure it is removed or fully open. Instructions state there should be no restriction after the valve.
Mesh filter blocked on inlet	Remove valve. Check to ensure filter on the inlet side of the valve is clear.
Flow regulator	Ensure the flow regulator is fully opened; when the valve is letting water run, turn down to the required flow rate.
High water pressure (above 6 bar)	Fit pressure reducing valve before the IRC valve.
No power	Ensure unit is powered. Change batteries if battery powered; ensure mains electrical power is functioning if mains powered.

water is continuously flowing through the valve

User perception

Once activated the valve remains open for a period of 30 minutes and will reactivate if someone comes within the range of the sensor in the last five minutes of the 30 minute period. The valve appears to work continuously as long as someone is in the washroom.

No power

The power has failed while the valve is in the 'open' position. Ensure the unit is powered. Change batteries if battery powered; ensure mains electrical power is functioning if mains powered.

Valve incorrectly fitted

Ensure the arrow on the brass body is pointing in the direction of water flow.

the valve remains shut when the room is occupied but opens at other times

Incorrect remote wiring

If the valve and sensor have been set up remotely, ensure the remote wiring is wired as follows: '1' to '1' and '2' to '2'. If you find the wiring is connected '1' to '2' and '2' to '1' then the valve is working in reverse.

water flow rate through the valve seems to be very slow

Flow regulation

Increase the flow rate by turning the flow regulator anti-clockwise until you reach your desired flow rate; ideally it should fill the cistern once per activation and then flush. See Step 5 'Commissioning'

Mesh filter blocked

Check to ensure filter on the inlet side of the valve is clear.

Flow restrictor/insert

The valves comes with a factory fitted 1.5mm diameter insert fitted for water pressures of 2 - 6 bar; this should be changed over to the 3mm insert (for water pressures of 0.1 - 2 bar) to allow more water through. See Step 3 'Valve Installation'.

water flow rate through the valve is fast and the cistern is flushing too frequently

Flow regulator

Decrease the flow rate by turning the flow regulator clockwise until you reach your desired flow rate. Ideally it should fill the cistern once per activation (i.e. every 30 minutes) and then flush. See Step 5 'Commissioning'.

9 Frequently asked questions

there is a leak around the solenoid

If the black bracket/solenoid has been removed from the block and rotated for flow orientation the 'O' ring seal at the join may be dislodged or lost

If dislodged, re-position. If lost; call Cistermiser.

I have just changed the batteries and there is no power to the unit

Battery orientation

Check battery orientation; ensure there is not excessive corrosion on battery terminals. Ensure batteries are a reputable brand.

cistermiser product warranty and extended warranty

Cistermiser products are guaranteed for 12 months from the date of manufacture. The guarantee is for faulty products and parts only: there is no labour warranty. If you believe your product is faulty, please either contact Cistermiser directly on **0118 969 1611** or at **warranty@cistermiser.co.uk**, with a photograph and the serial number, to help diagnose the cause of the problem.

The warranty on Cistermiser products can be extended within one year of date of manufacture, at no cost, to three years from the date of installation by completing the enclosed warranty card or at **www.cistermiser.co.uk/warranty**. Please make a note of the serial number and take a photograph of the installation before you leave site.

commissioning check-list

IRC

Cistermiser products are guaranteed for 12 months from the date of manufacture. The guarantee is for manufacturing defects only: there is no labour warranty.

3 YEAR
warranty

The warranty on Cistermiser products can be extended within one year of date of manufacture, at no cost, to three years from the date of installation by completing online registration at www.cistermiser.co.uk/product-registration and completing and returning the commissioning checklist below.

This commissioning checklist is to be completed in full by the competent person who installed the product as a means of demonstrating compliance with the installation instructions and then returned to: Cistermiser Ltd., Unit 1, Woodley Park Estate, 59-69 Reading Road, Woodley, Berks, RG5 3AN.

product serial number

installation address

No	Activity	Checked	Date
1	Flush pipework prior to installation.	<input type="checkbox"/>	<input type="checkbox"/>
2	Correct valve seat fitted: 1.5mm 2 – 6 Bar (factory fitted). 3.0mm 0.1 – 2 Bar.	<input type="checkbox"/>	<input type="checkbox"/>
3	Ensure the flow direction through the valve is correct.	<input type="checkbox"/>	<input type="checkbox"/>
4	Ceiling mounted: ensure sensor range will cover urinal area.	<input type="checkbox"/>	<input type="checkbox"/>
5	Electrical connections: ensure mains or battery power is connected. If mains powered, ensure mains adaptor is wired to 1A fused spur.	<input type="checkbox"/>	<input type="checkbox"/>
6	Remote solenoid: check connections from sensor to solenoid are correctly wired. i.e. terminal 1 to 1 and terminal 2 to 2 between the sensor box and the solenoid.	<input type="checkbox"/>	<input type="checkbox"/>
7	Set flow rate: cistern should not fill more than once in a period of 30 minutes. Turn flow restrictor clockwise to reduce flow rate, anti-clockwise to increase flow rate.	<input type="checkbox"/>	<input type="checkbox"/>
8	Press Test Button: valve test mode, valve will open and close five times. Sensor test mode for one minute, body movement will cause amber LED to flash. Sensor reverts to normal operation after test program.	<input type="checkbox"/>	<input type="checkbox"/>

cistermiser range

urinal flushing



hydraulic valve

An automatic urinal flush control valve which reduces water consumption and odours. The valve uses a simple patented mechanism which prevents water waste by ensuring that the auto-flush cistern is only filled, and can only flush, when the washroom is used.



infrared control (IRC) valve

This valve automatically manages the water supply to the urinal cistern and reduces water consumption by up to 80%. The PIR sensor detects movement and activates the solenoid valve, allowing water into a urinal cistern.



direct flush valve

An infrared sensor controlled urinal valve. It automatically flushes individual urinals after use, ensuring the highest level of hygiene from the minimum volume of water.

wc flushing



easyflush wave

An infrared, hands-free and water-conserving WC cistern flush valve suitable for concealed or exposed cisterns. Easy to install in retrofits or new installations, its no-touch dual flush WC cistern valve promotes water economy and hygiene in domestic and commercial washrooms.



easyflush walkaway

An infrared controlled automatic wc cistern flush valve that is suitable for concealed cisterns. The valve flushes once the user exits the cubicle. Ideal for use in environments where hygiene and water economy are concerns.



easyflush direct

An infrared electronic flushing system that removes the need for a WC cistern by taking its water feed straight from the mains supply. Ideal for high traffic areas as the system allows for a second flush without a delay.

taps



novatap/vectatap

An infrared tap which promotes hygiene and reduces maintenance costs. It is a contemporary deck-mounted chrome basin spout with infrared sensor, control unit and valve (novatap - internal, vectatap - external) in its body, making it extremely simple to install.



vectaspout

A polished stainless steel panel-mounted basin spout. The infrared control reduces water and energy usage and stops dripping or the risk that the tap may be left running. It is completely hands-free and reduces cross contamination.



novaspout

Helps improve water and energy efficiency with its automatic shut-off, eliminating the risk of dripping or taps left running. It is an elegant panel-mounted polished stainless steel basin spout supplied with an infrared sensor control unit and valve.

total washroom control management systems



anti-vandal range

Our specialist vandal-resistant range of touch-activated washroom controls; for use in high risk or demanding public environments, such as prisons, secure hospitals, schools and sports facilities.



sensazone

An innovative system to conserve water and energy. Occupancy is monitored by sensors; when someone enters the washroom all services controlled by Sensazone are activated - the hot and cold water, lighting and extractor fans.



Davidson Holdings' brands

Salamander Pumps

Quality | Technology | Service | Value



salamander is one of the UK's leading manufacturers of pumps for boosting water pressure for showers, bathrooms and whole house supply in domestic and small commercial tank-fed systems.



www.salamanderpumps.co.uk

Talon

talon is the UK market leader in the manufacture and supply of plastic pipe clips, pipe collars and fixing plugs, plus a range of cover profiles for concealing pipework.



www.talon.co.uk



keraflo manufacture delayed action float valves, which provide an accurate and effective method of controlling the level of stored cold water in tanks both with and without raised float valve chambers. The range is used in domestic, commercial and industrial applications worldwide.



www.keraflo.co.uk



COMBIMATE

GUARANTEED LIMESCALE PREVENTION

combimate is a domestic limescale prevention device that prevents limescale build-up and soft water corrosion in combination boilers and other domestic hot water appliances.



www.combimate.co.uk



Giving your mains water the boost it needs

homeboost is an intelligent pump from Salamander Pumps that recognises when water flow is less than 12 ltrs/min and automatically boosts the performance of the incoming mains water up to 12 ltrs/min.



www.home-boost.co.uk



FUELSTOP

THERMOSTATIC FIRE VALVE

fuelstop TFV is an overheat protection device that shuts off supply to fuel burning appliances. The FuelStop TFV complies with British safety standards and, unlike other fire valves, it is filled with liquid not gas, reducing nuisance trips.



www.fuelstop.co.uk

Cistermiser Unit 1, Woodley Park Estate,
59-69 Reading Road, Woodley, Reading Berkshire RG5 3AN

cistermiser
water management at its best

0118 969 1611 | sales@cistermiser.co.uk | www.cistermiser.co.uk

A Davidson Holdings company **IPAC/15 B-01**