

DATA SHEET

74LVC126A

Quad buffer/line driver with 5-volt tolerant inputs/outputs (3-State)

Product specification
Supersedes data of 1997 Aug 01
IC24 Data Handbook

1998 Apr 28

Quad buffer/line driver with 5-volt tolerant inputs/outputs (3-state)

74LVC126A

FEATURES

- 5-volt tolerant inputs/outputs, for interfacing with 5-volt logic
- Supply voltage range of 1.2V to 3.6V
- Complies with JEDEC standard no. 8-1A
- CMOS low power consumption
- Direct interface with TTL levels
- High impedance when $V_{CC} = 0V$

DESCRIPTION

The 74LVC126A is a high performance, low-power, low-voltage Si-gate CMOS device and superior to most advanced CMOS compatible TTL families.

Inputs can be driven from either 3.3V or 5.0V devices. In 3-state operation, outputs can handle 5V.

The 74LVC126A consists of four non-inverting buffers/line drivers with 3-state outputs. The 3-state outputs (nY) are controlled by the output enable input (nOE). A LOW at nOE causes the outputs to assume a high impedance OFF-state.

QUICK REFERENCE DATA

GND = 0 V; $T_{amb} = 25^{\circ}C$; $t_r = t_f \leq 2.5$ ns

SYMBOL	PARAMETER	CONDITIONS	TYPICAL	UNIT
t_{PHL}/t_{PLH}	Propagation delay nA to nY	$C_L = 50$ pF; $V_{CC} = 3.3$ V	3.0	ns
C_I	Input capacitance		5.0	pF
C_{PD}	Power dissipation capacitance per buffer	$V_{CC} = 3.3$ V	20	pF

NOTES:

- C_{PD} is used to determine the dynamic power dissipation (P_D in μW)
 $P_D = C_{PD} \times V_{CC}^2 \times f_i + \sum (C_L \times V_{CC}^2 \times f_o)$ where:
 f_i = input frequency in MHz; C_L = output load capacity in pF;
 f_o = output frequency in MHz; V_{CC} = supply voltage in V;
 $\sum (C_L \times V_{CC}^2 \times f_o)$ = sum of the outputs.
- The condition is $V_I = GND$ to V_{CC}

ORDERING INFORMATION

PACKAGES	TEMPERATURE RANGE	OUTSIDE NORTH AMERICA	NORTH AMERICA	PKG. DWG. #
14-Pin Plastic SO	$-40^{\circ}C$ to $+125^{\circ}C$	74LVC126A D	74LVC126A D	SOT108-1
14-Pin Plastic SSOP Type II	$-40^{\circ}C$ to $+125^{\circ}C$	74LVC126A DB	74LVC126A DB	SOT337-1
14-Pin Plastic TSSOP Type I	$-40^{\circ}C$ to $+125^{\circ}C$	74LVC126A PW	74LVC126APW DH	SOT402-1

PIN CONFIGURATION

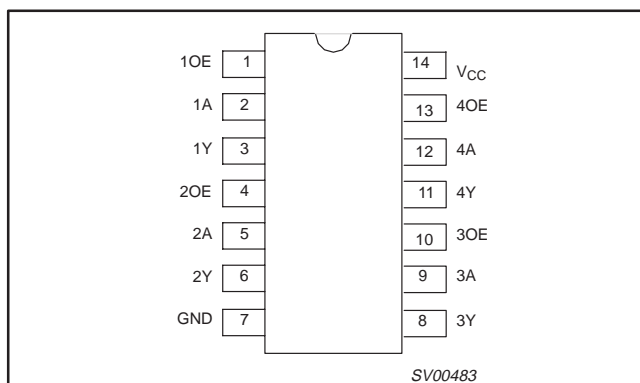

PIN DESCRIPTION

PIN NUMBER	SYMBOL	NAME AND FUNCTION
1, 4, 10, 13	1OE – 4OE	Data enable inputs (active HIGH)
2, 5, 9, 12	1A – 4A	Data inputs
3, 6, 8, 11	1Y – 4Y	Data Outputs
7	GND	Ground (0 V)
14	V_{CC}	Positive supply voltage

Quad buffer/line driver with 5-volt tolerant inputs/outputs (3-state)

74LVC126A

LOGIC SYMBOL

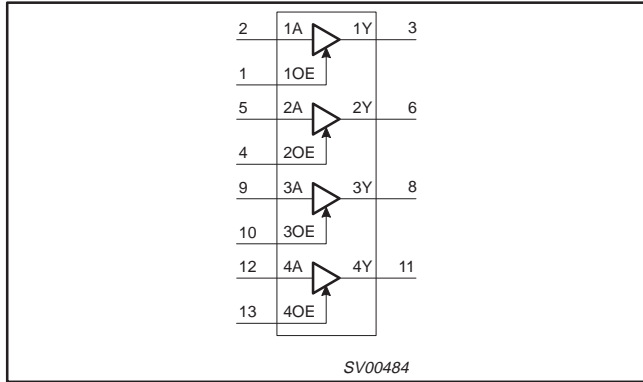

LOGIC SYMBOL (IEEE/IEC)

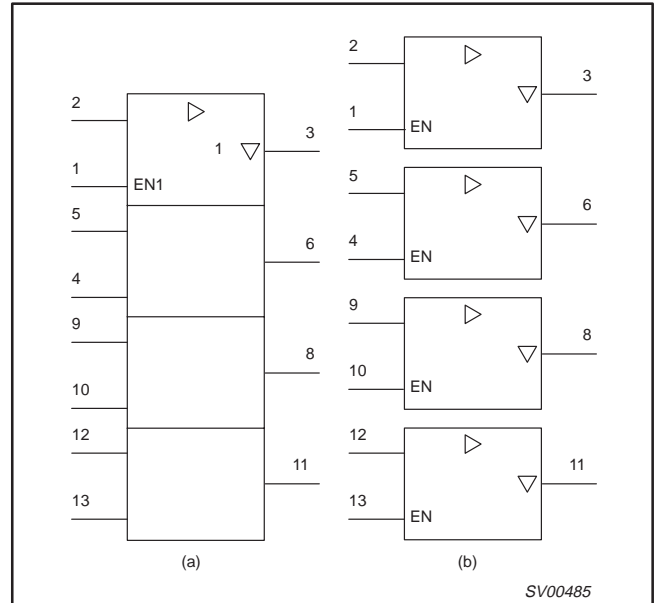

FUNCTION TABLE

INPUTS		OUTPUT
nOE	nA	nY
H	L	L
H	H	H
L	X	Z

NOTES:

- H = HIGH voltage level
- L = LOW voltage level
- X = don't care
- Z = high impedance OFF-state

LOGIC DIAGRAM

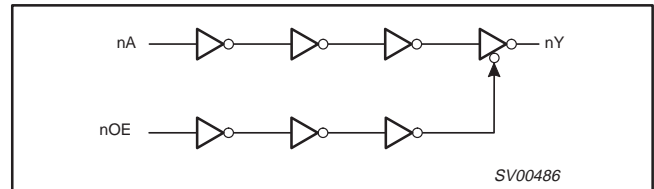

RECOMMENDED OPERATING CONDITIONS

SYMBOL	PARAMETER	CONDITIONS	LIMITS		UNIT
			MIN	MAX	
V _{CC}	DC supply voltage (for max. speed performance)		2.7	3.6	V
	DC supply voltage (for low-voltage applications)		1.2	3.6	
V _I	DC input voltage range		0	5.5	V
V _O	DC output voltage range; output HIGH or LOW state		0	V _{CC}	V
	DC output voltage range; output 3-State		0	5.5	
T _{amb}	Operating ambient temperature range in free-air		-40	+85	°C
t _p , t _f	Input rise and fall times	V _{CC} = 1.2 to 2.7V	0	20	ns/V
		V _{CC} = 2.7 to 3.6V	0	10	

Quad buffer/line driver with 5-volt tolerant inputs/outputs (3-state)

74LVC126A

ABSOLUTE MAXIMUM RATINGS¹

In accordance with the Absolute Maximum Rating System (IEC 134)

Voltages are referenced to GND (ground = 0V)

SYMBOL	PARAMETER	CONDITIONS	RATING	UNIT
V_{CC}	DC supply voltage		-0.5 to +6.5	V
I_{IK}	DC input diode current	$V_I < 0$	-50	mA
V_I	DC input voltage	Note 2	-0.5 to +5.5	V
I_{OK}	DC output diode current	$V_O > V_{CC}$ or $V_O < 0$	± 50	mA
V_O	DC output voltage; output HIGH or LOW state	Note 2	-0.5 to $V_{CC} + 0.5$	V
	DC output voltage; output 3-State	Note 2	-0.5 to 6.5	
I_O	DC output source or sink current	$V_O = 0$ to V_{CC}	± 50	mA
I_{GND}, I_{CC}	DC V_{CC} or GND current		± 100	mA
T_{stg}	Storage temperature range		-65 to +150	°C
P_{TOT}	Power dissipation per package – plastic mini-pack (SO) – plastic shrink mini-pack (SSOP and TSSOP)	above +70°C derate linearly with 8 mW/K	500	mW
		above +60°C derate linearly with 5.5 mW/K	500	

NOTES:

- Stresses beyond those listed may cause permanent damage to the device. These are stress ratings only and functional operation of the device at these or any other conditions beyond those indicated under "recommended operating conditions" is not implied. Exposure to absolute-maximum-rated conditions for extended periods may affect device reliability.
- The input and output voltage ratings may be exceeded if the input and output current ratings are observed.

DC ELECTRICAL CHARACTERISTICS

Over recommended operating conditions voltages are referenced to GND (ground = 0V)

SYMBOL	PARAMETER	TEST CONDITIONS	LIMITS			UNIT
			Temp = -40°C to +85°C			
			MIN	TYP ¹	MAX	
V_{IH}	HIGH level Input voltage	$V_{CC} = 1.2V$	V_{CC}			V
		$V_{CC} = 2.7$ to $3.6V$	2.0			
V_{IL}	LOW level Input voltage	$V_{CC} = 1.2V$			GND	V
		$V_{CC} = 2.7$ to $3.6V$			0.8	
V_{OH}	HIGH level output voltage	$V_{CC} = 2.7V; V_I = V_{IH}$ or $V_{IL}; I_O = -12mA$	$V_{CC} - 0.5$			V
		$V_{CC} = 3.0V; V_I = V_{IH}$ or $V_{IL}; I_O = -100\mu A$	$V_{CC} - 0.2$	V_{CC}		
		$V_{CC} = 3.0V; V_I = V_{IH}$ or $V_{IL}; I_O = -18mA$	$V_{CC} - 0.6$			
		$V_{CC} = 3.0V; V_I = V_{IH}$ or $V_{IL}; I_O = -24mA$	$V_{CC} - 0.8$			
V_{OL}	LOW level output voltage	$V_{CC} = 2.7V; V_I = V_{IH}$ or $V_{IL}; I_O = 12mA$			0.40	V
		$V_{CC} = 3.0V; V_I = V_{IH}$ or $V_{IL}; I_O = 100\mu A$			0.20	
		$V_{CC} = 3.0V; V_I = V_{IH}$ or $V_{IL}; I_O = 24mA$			0.55	
I_I	Input leakage current	$V_{CC} = 3.6V; V_I = 5.5V$ or GND		± 0.1	± 5	μA
I_{OZ}	3-State output OFF-state current	$V_{CC} = 0.0V; V_I$ or $V_O = 5.5V$			± 5	μA
I_{OFF}	Power off leakage current	$V_{CC} = 3.6V; V_I = V_{IH}$ or $V_{IL}; V_O = V_{CC}$ or GND		0.1	± 10	μA
I_{CC}	Quiescent supply current	$V_{CC} = 3.6V; V_I = V_{CC}$ or GND; $I_O = 0$		0.1	10	μA
ΔI_{CC}	Additional quiescent supply current per input pin	$V_{CC} = 2.7V$ to $3.6V; V_I = V_{CC} - 0.6V; I_O = 0$		5	500	μA

NOTES:

- All typical values are at $V_{CC} = 3.3V$ and $T_{amb} = 25^\circ C$.

Quad buffer/line driver with 5-volt tolerant inputs/outputs (3-state)

74LVC126A

AC CHARACTERISTICS

GND = 0 V; $t_r = t_f = 2.5$ ns; $C_L = 50$ pF; $R_L = 500\Omega$

SYMBOL	PARAMETER	WAVEFORM	LIMITS						UNIT
			$V_{CC} = 3.3V \pm 0.3V$			$V_{CC} = 2.7V$		$V_{CC} = 1.2V$	
			MIN	TYP ¹	MAX	MIN	MAX	TYP	
t_{PHL} t_{PLH}	Propagation delay nA to nY	Figures 1, 3	1.5	3.2	5.5	1.5	6.5	13.0	ns
t_{PZH} t_{PZL}	3-state output enable time nOE to nY	Figures 2, 3	1.5	3.9	6.3	1.5	7.3	13.0	ns
t_{PHZ} t_{PLZ}	3-state output disable time nOE to nY	Figures 2, 3	1.5	4.4	6.2	1.5	7.2	10	ns

NOTE:

1. These typical values are at $V_{CC} = 3.3V$ and $T_{amb} = 25^\circ C$.

AC WAVEFORMS

$V_M = 1.5$ V at $V_{CC} \geq 2.7$ V

$V_M = 0.5 \cdot V_{CC}$ at $V_{CC} < 2.7$ V

V_{OL} and V_{OH} are the typical output voltage drop that occur with the output load.

$V_X = V_{OL} + 0.3$ V at $V_{CC} \geq 2.7$ V; $V_X = V_{OL} + 0.1 \cdot V_{CC}$ at $V_{CC} < 2.7$ V

$V_Y = V_{OH} - 0.3$ V at $V_{CC} \geq 2.7$ V; $V_Y = V_{OH} - 0.1 \cdot V_{CC}$ at $V_{CC} < 2.7$ V

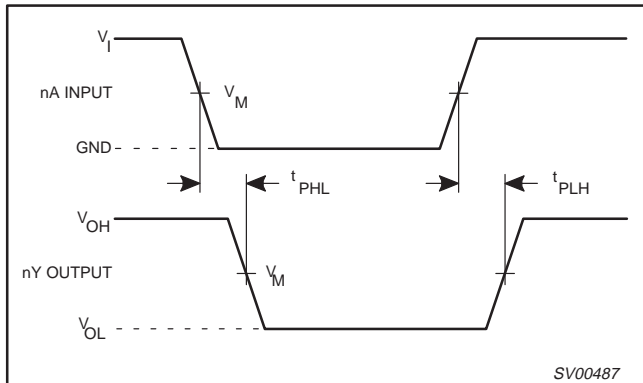

Figure 1. Input (nA) to output (nY) propagation delays.

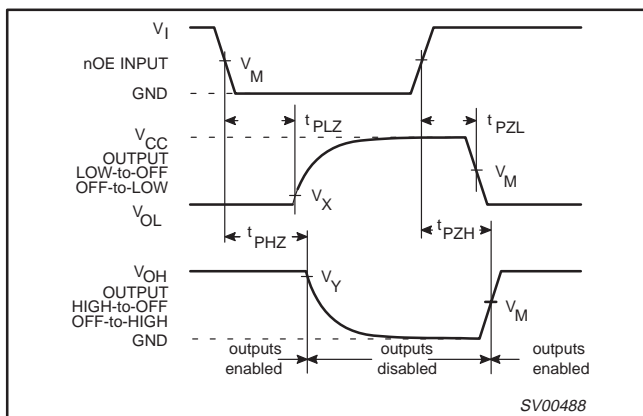

Figure 2. 3-state enable and disable times.

TEST CIRCUIT

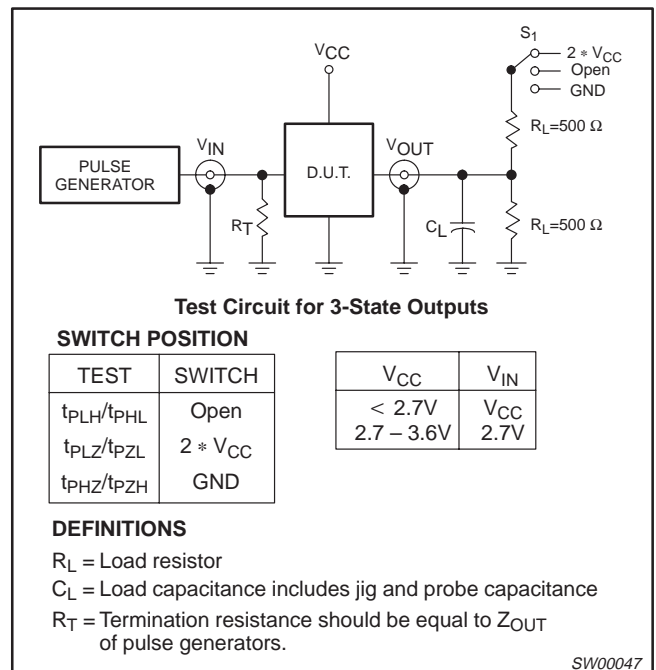

Figure 3. Load circuitry for switching times.

Quad buffer/line driver with 5-volt tolerant inputs/outputs (3-State)

74LVC126A

SO14: plastic small outline package; 14 leads; body width 3.9 mm

SOT108-1

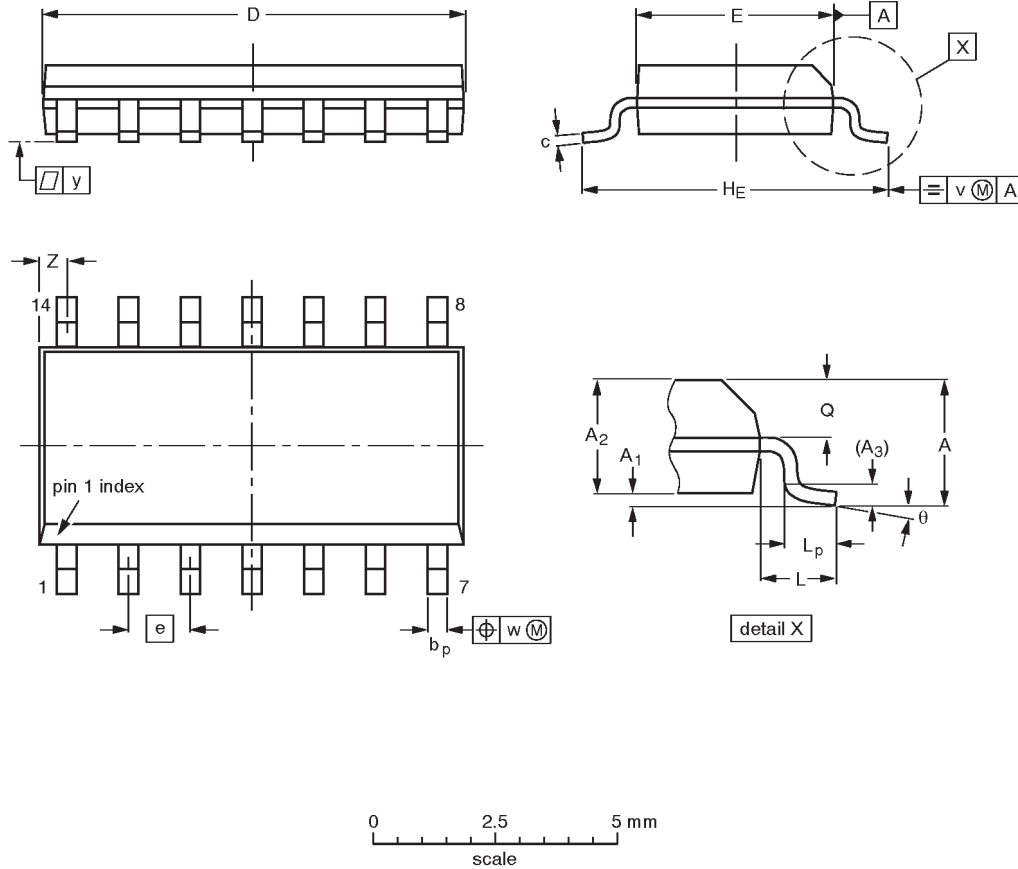

DIMENSIONS (inch dimensions are derived from the original mm dimensions)

UNIT	A max.	A ₁	A ₂	A ₃	b _p	c	D ⁽¹⁾	E ⁽¹⁾	e	H _E	L	L _p	Q	v	w	y	Z ⁽¹⁾	θ
mm	1.75	0.25 0.10	1.45 1.25	0.25	0.49 0.36	0.25 0.19	8.75 8.55	4.0 3.8	1.27	6.2 5.8	1.05	1.0 0.4	0.7 0.6	0.25	0.25	0.1	0.7 0.3	8° 0°
inches	0.069	0.0098 0.0039	0.057 0.049	0.01	0.019 0.014	0.0098 0.0075	0.35 0.34	0.16 0.15	0.050	0.24 0.23	0.041	0.039 0.016	0.028 0.024	0.01	0.01	0.004	0.028 0.012	

Note

1. Plastic or metal protrusions of 0.15 mm maximum per side are not included.

OUTLINE VERSION	REFERENCES				EUROPEAN PROJECTION	ISSUE DATE
	IEC	JEDEC	EIAJ			
SOT108-1	076E06S	MS-012AB				91-08-13 95-01-23

Quad buffer/line driver with 5-volt tolerant inputs/outputs (3-State)

74LVC126A

SSOP14: plastic shrink small outline package; 14 leads; body width 5.3 mm

SOT337-1

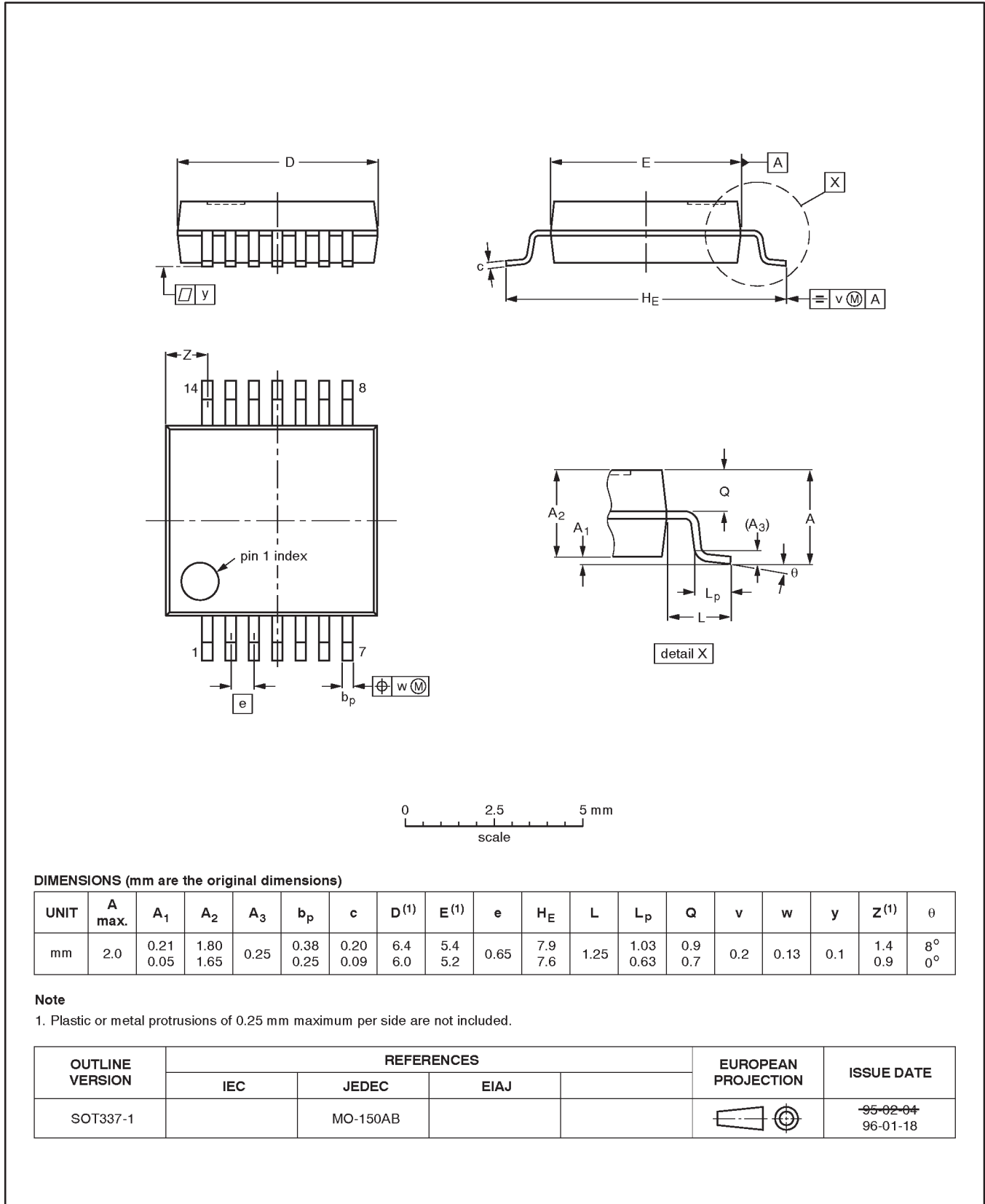

DIMENSIONS (mm are the original dimensions)

UNIT	A max.	A ₁	A ₂	A ₃	b _p	c	D ⁽¹⁾	E ⁽¹⁾	e	H _E	L	L _p	Q	v	w	y	Z ⁽¹⁾	θ
mm	2.0	0.21 0.05	1.80 1.65	0.25	0.38 0.25	0.20 0.09	6.4 6.0	5.4 5.2	0.65	7.9 7.6	1.25	1.03 0.63	0.9 0.7	0.2	0.13	0.1	1.4 0.9	8° 0°

Note

1. Plastic or metal protrusions of 0.25 mm maximum per side are not included.

OUTLINE VERSION	REFERENCES				EUROPEAN PROJECTION	ISSUE DATE
	IEC	JEDEC	EIAJ			
SOT337-1		MO-150AB				95-02-04 96-01-18

Quad buffer/line driver with 5-volt tolerant inputs/outputs (3-State)

74LVC126A

TSSOP14: plastic thin shrink small outline package; 14 leads; body width 4.4 mm

SOT402-1

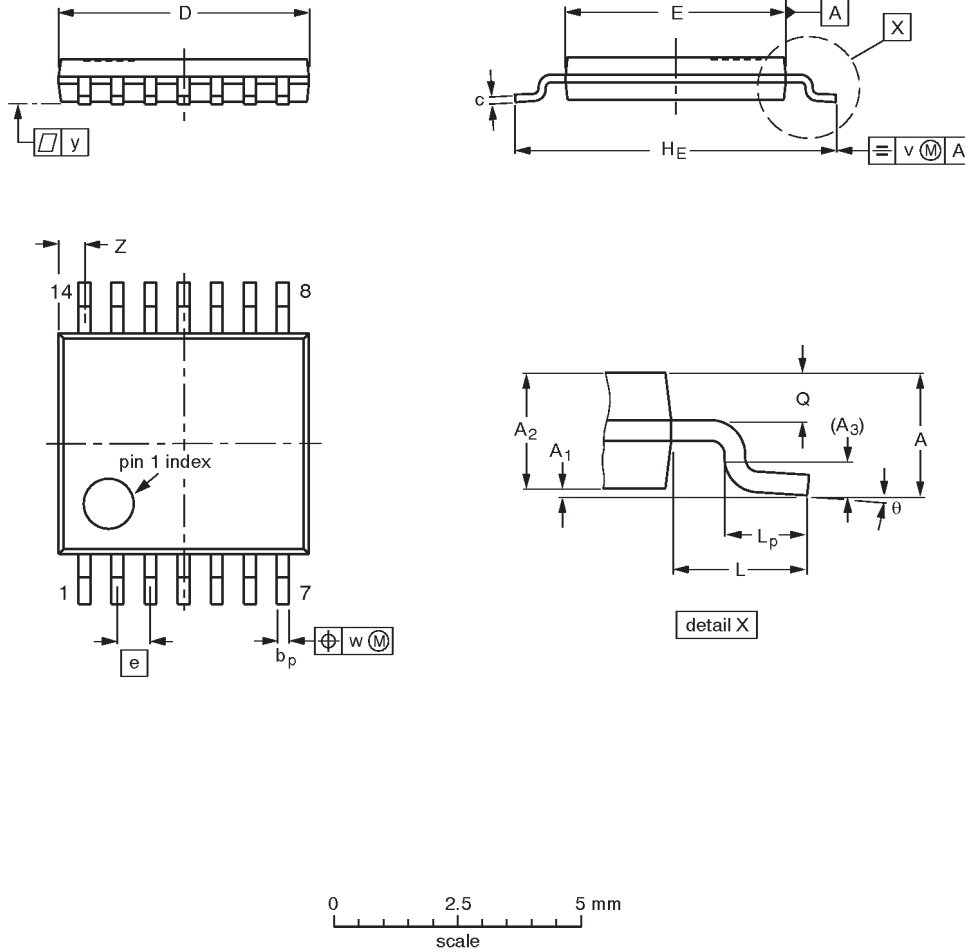

DIMENSIONS (mm are the original dimensions)

UNIT	A max.	A ₁	A ₂	A ₃	b _p	c	D ⁽¹⁾	E ⁽²⁾	e	H _E	L	L _p	Q	v	w	y	Z ⁽¹⁾	θ
mm	1.10	0.15 0.05	0.95 0.80	0.25	0.30 0.19	0.2 0.1	5.1 4.9	4.5 4.3	0.65	6.6 6.2	1.0	0.75 0.50	0.4 0.3	0.2	0.13	0.1	0.72 0.38	8° 0°

Notes

1. Plastic or metal protrusions of 0.15 mm maximum per side are not included.
2. Plastic interlead protrusions of 0.25 mm maximum per side are not included.

OUTLINE VERSION	REFERENCES				EUROPEAN PROJECTION	ISSUE DATE
	IEC	JEDEC	EIAJ			
SOT402-1		MO-153				-94-07-12- 95-04-04