

LEVINA

5377PJP100P30-11 Grey

EAN 4031582445336

Swivel castor with total lock, tail end of castor, housing and wheels made from high grade synthetic materials, double ball bearing swivel head, bolt hole. Wheel centre made of Polypropylene, Tread: TENTEprene (thermoplastic rubber), grey non-marking, precision ball bearing
Hint: These castors are also with grey locking lever available.



BETTER MOBILITY. BETTER LIFE.



Picture may differ from original product

Technical Data

Wheel diameter	100 mm
Width of Tread	32 mm
Centre hole	11 mm
Offset	36 mm
Swivel Interference	196 mm
Overall height	137 mm
Temperature	- 10 / + 40 °C
Standard	EN 12530
Weight	0.474 kg
Swivel Radius	98 mm
Hardness of tread	Shore A 87
Load capacity	100 kg
Load capacity (static)	200 kg

Advantages at a glance

Roll performance	● ● ● ○ ○
Movement noise	● ● ● ● ○
Attrition	● ● ● ○ ○
Corrosion resistance	● ● ● ● ○

Dimensions

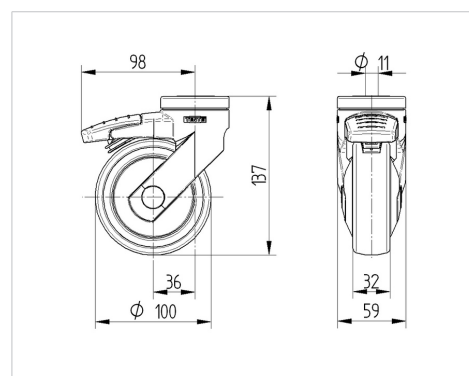

Structure & Mounting

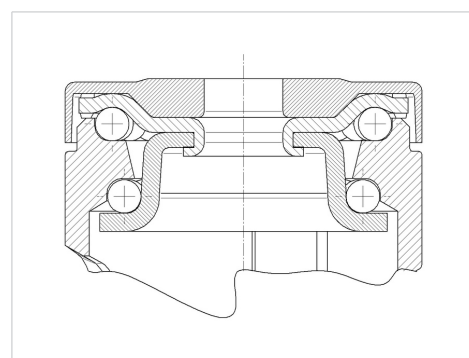

PRODUCT INFORMATION

LEVINA

5377PJP100P30-11 Grey

EAN 4031582445336



BETTER MOBILITY. BETTER LIFE.

Structure & Mounting

