

NEW

OMRON

# RFID System

## V680 Series

Next-Generation RFID System Conforming to ISO/IEC 18000-3 (ISO/IEC 15693).  
New 100-mm × 100-mm Antennas Available.

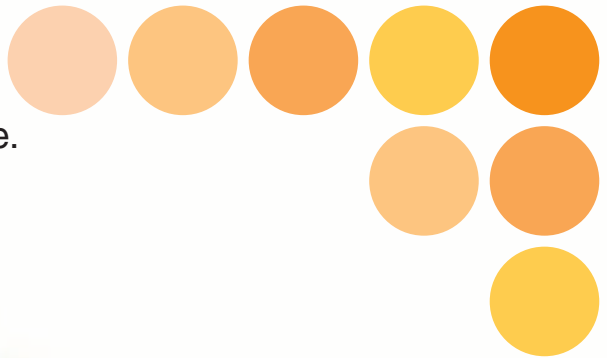

Visualize data transmission on production lines.

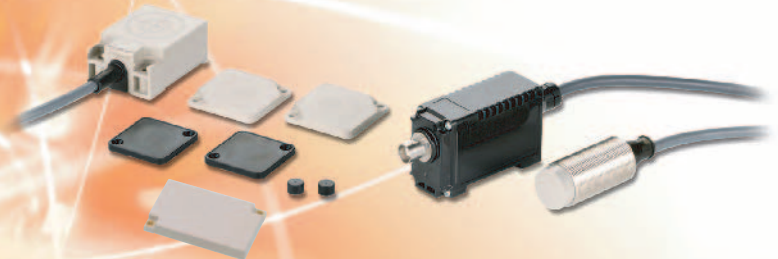

Managing process instructions and histories for engine manufacturing

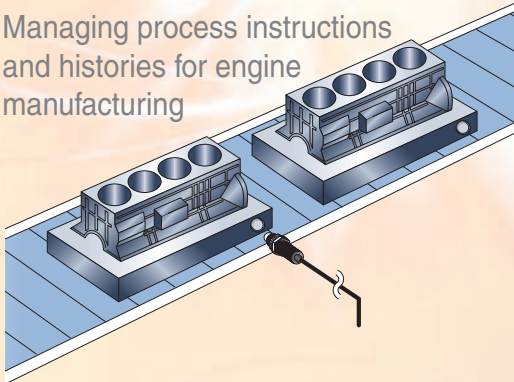

Managing manufacturing process traceability

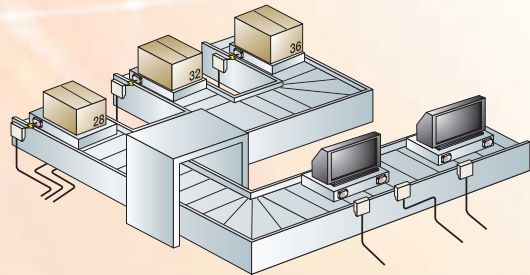

Managing the manufacture of LCDs and color filters

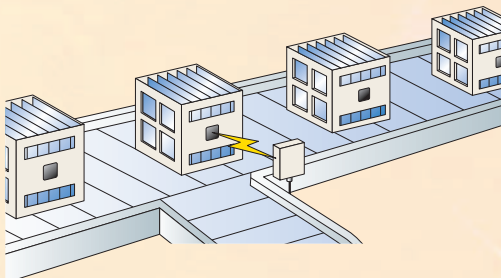

Managing dies, die histories, and die service lives

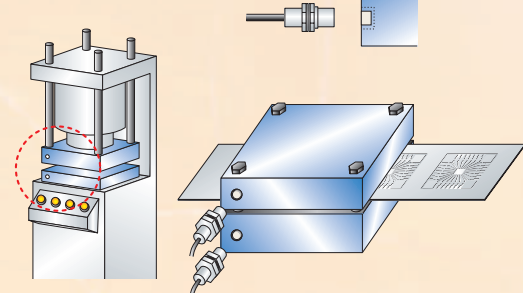

realizing

# Versatile Functions for Optimal Use on Production Lines

## Conforms to ISO/IEC 18000-3 (ISO/IEC 15693)

### Can be used in many countries around the world.

The V680 Series can be used in many parts of the world because it meets the requirements of radio wave regulations in Japan, Europe, the U.S.A., Canada, Mexico, Singapore, Malaysia, the Philippines, China, Hong Kong, Taiwan, and Korea. (The V680-HS65/-H01 meets the requirements of radio wave regulations in Japan, Europe, and the U.S.A.) Contact your OMRON sales representative for details on use in other countries.

## Enables High-speed Data Transmission

### High-speed transmission of 27 kbps achieved.

The V680 Series offers data transmission speeds as high as 27 kbps at an operating frequency of 13.56 MHz, and dramatically shortens turn around time (TAT) with a Self-execution Mode that eliminates the need for host access.

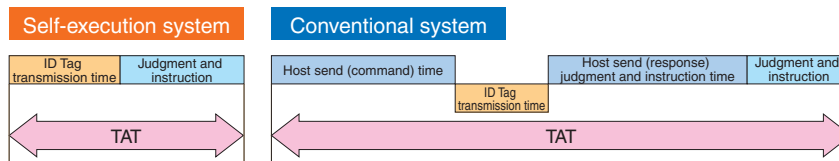

## A Wide Range of ID Tags Available for Various Production Lines

### These ultra-compact Tags also feature high environmental durability, long service lives, and maintenance-free operation.

- ID Tags can be either embedded in metal or mounted on non-metallic objects without requiring any extra attachments.
- A long service life enables 10 billion accesses.
- A new battery-less model with a large, 32-Kbyte capacity has been added to the line-up. In addition to managing the growing amount of production and quality data on today's factory floors, this new Tag makes it easy to build a system with traceability.
- The V680 Series features the same level of environmental durability as the previous V600 Series.



**10 billion accesses**  
Long service life

**Battery-less**

## No Changes Needed when Switching from an Existing System

The V680 Series also supports V600-series commands, so there is no need to change command systems.

## Easier Startup and Maintenance. Simpler Operation.

### Lets You Visualize Data Transmission

Contributes to higher efficiency for on-site startup and maintenance.

Seven maintenance modes make it easy to diagnose the optimal usage conditions for the V680 RFID System. Startup is also easier because the system can be checked without having to use a personal computer or other host device.

Maintenance modes are quickly switched with the DIP switch on the front of the Controller.

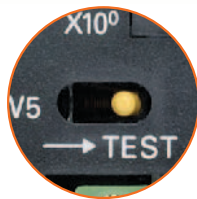

The Amplifier Unit is also equipped with an indicator that displays the communications condition, for easy confirmation from the location nearest the production line.

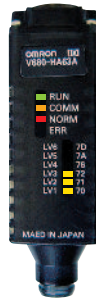

### Strong Support for Creating ID Tag Memory Maps

Using the ID Map Manager dramatically shortens the time required to allocate ID Tag memory and complete system designs.

Work efficiency is greatly increased because the ID Map Manager includes an ID Tag read/write test function and communications checking function in addition to memory map definition and editing functions. Memory map data created by the ID Map Manager can also be easily shared between the production line design department and the vendors that are building the line.

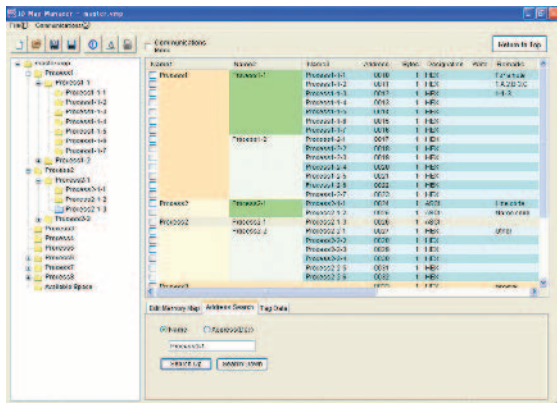

V680-A-IMMEG-P01

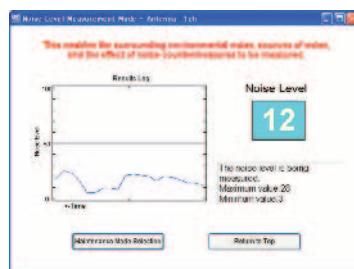

# Visualize Data Transmission without the Need for a Host Device. Perform Simple Diagnosis of Communications Conditions.

## Distance Level Measurement Mode

Confirms correct mounting positions for the Read/Write Antenna and ID Tag.

The distance between the Read/Write Antenna and ID Tag mounting locations relative to the communications range is displayed using six levels.

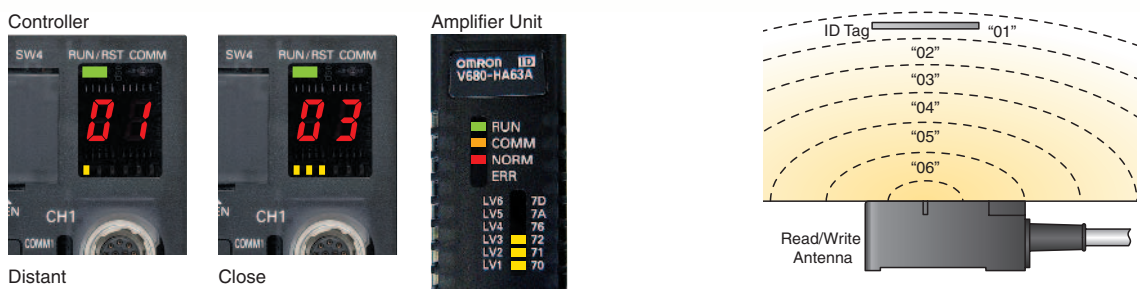

## Noise Level Measurement Mode

Confirms spatial noise, noise sources, and noise countermeasure effects.

Measures the ambient noise level and displays it in levels ranging from 00 to 99.



## Speed Level Measurement Mode (Read/Write)

Confirms the speed of moving ID Tags and the number of usable bytes.

Data is transmitted repeatedly to moving ID Tags, and the number of successful communications and speed level are displayed in levels ranging from 01 to 99.

(No data is actually written to the ID Tags during the write part of the Speed Level Measurement Mode.)

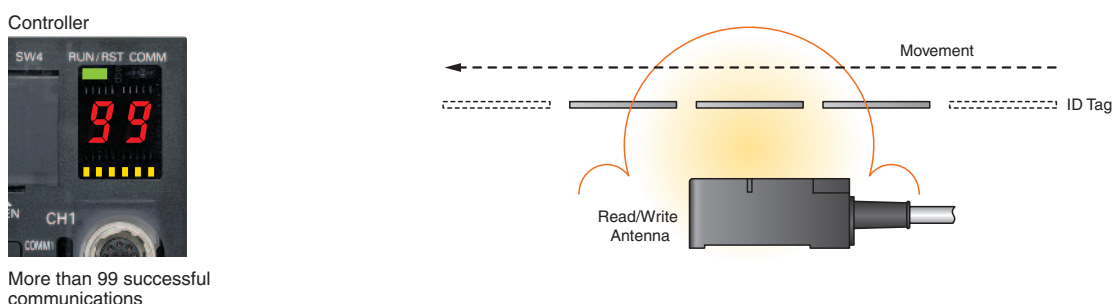

Seven maintenance modes make it easy to diagnose the communications conditions from the front panel of the Controller or Amplifier Unit. The data can also be output from the USB port of the Controller to a personal computer or other monitoring device.

(Maintenance Mode cannot be used when the V680-H01 Antenna is connected.)

## Communications Success Rate Measurement Mode

**Confirms the communications success rate between the Read/Write Antenna and ID Tags.**

A total of 100 communications are executed without retries, and the rate of communications success is displayed in levels ranging from 01 to 99.

Controller



Communications successes: 23

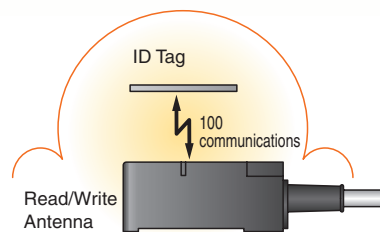

## Host Device Communications Monitor Mode (Protocol Analyzer Function)

**This mode can be used as a protocol analyzer function for host device communications lines.**

The communications commands sent from the host device and the execution result responses can be output from the USB port of the Controller.

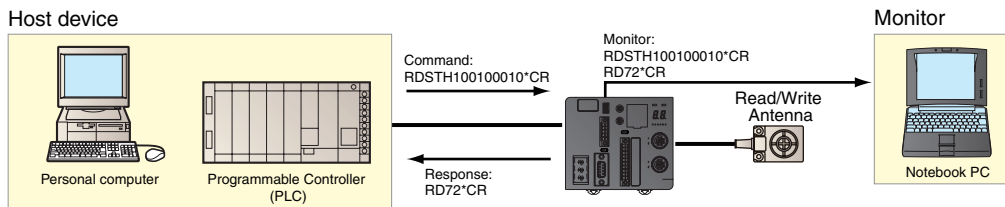

## Tag Communications Test Mode

**Confirms communications ability between the Read/Write Antenna and ID Tags.**

The end codes are displayed to show the results of communications between the Read/Write Antenna and ID Tags. When the Controller is mounted inside a control panel, or in some other location, this data can be output from the Controller's USB port and easily checked on a monitor.

(The Tag Communications Test Mode uses only read operations.)

Controller



Normal communication



Communications error

## Host Device Communications Confirmation Mode

**Confirms whether the signals sent from the Controller are being correctly transferred to an external device.**

The communications commands and responses between the Controller and a host device are output from the Controller's USB port for easy identification of problems, such as incorrect communications parameters or wiring.

# RFID System V680 Series

## New, Next-generation RFID Systems with ISO/IEC 18000-3 (ISO/IEC15693) Compliance

- High-speed, 27-kbps transmission response-only speed of 53 kbps from the V680-D□KF68.
- Read/Write Antennas and ID Tags with excellent environmental resistance.
- Wide line-up of ultra-compact, long-life ID Tags, with capacities from 1 to 32 Kbytes.
- Seven modes make it possible to visualize data transmission.
- ID Map Manager simplifies memory map designing for ID Tags.
- Complies with FCC Standards and R&TTE Directive.

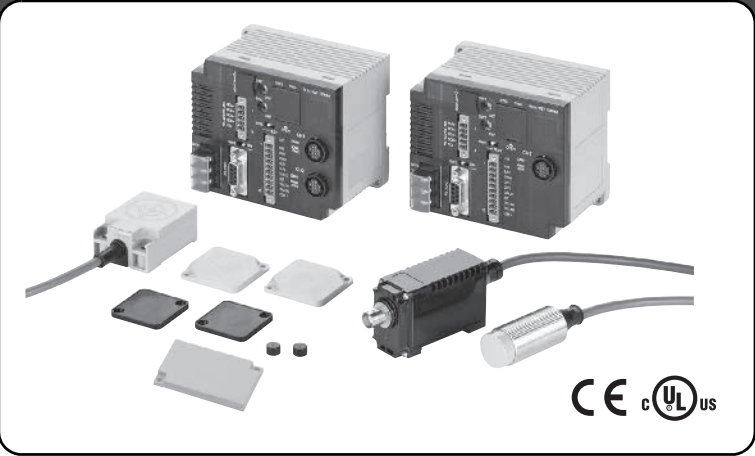



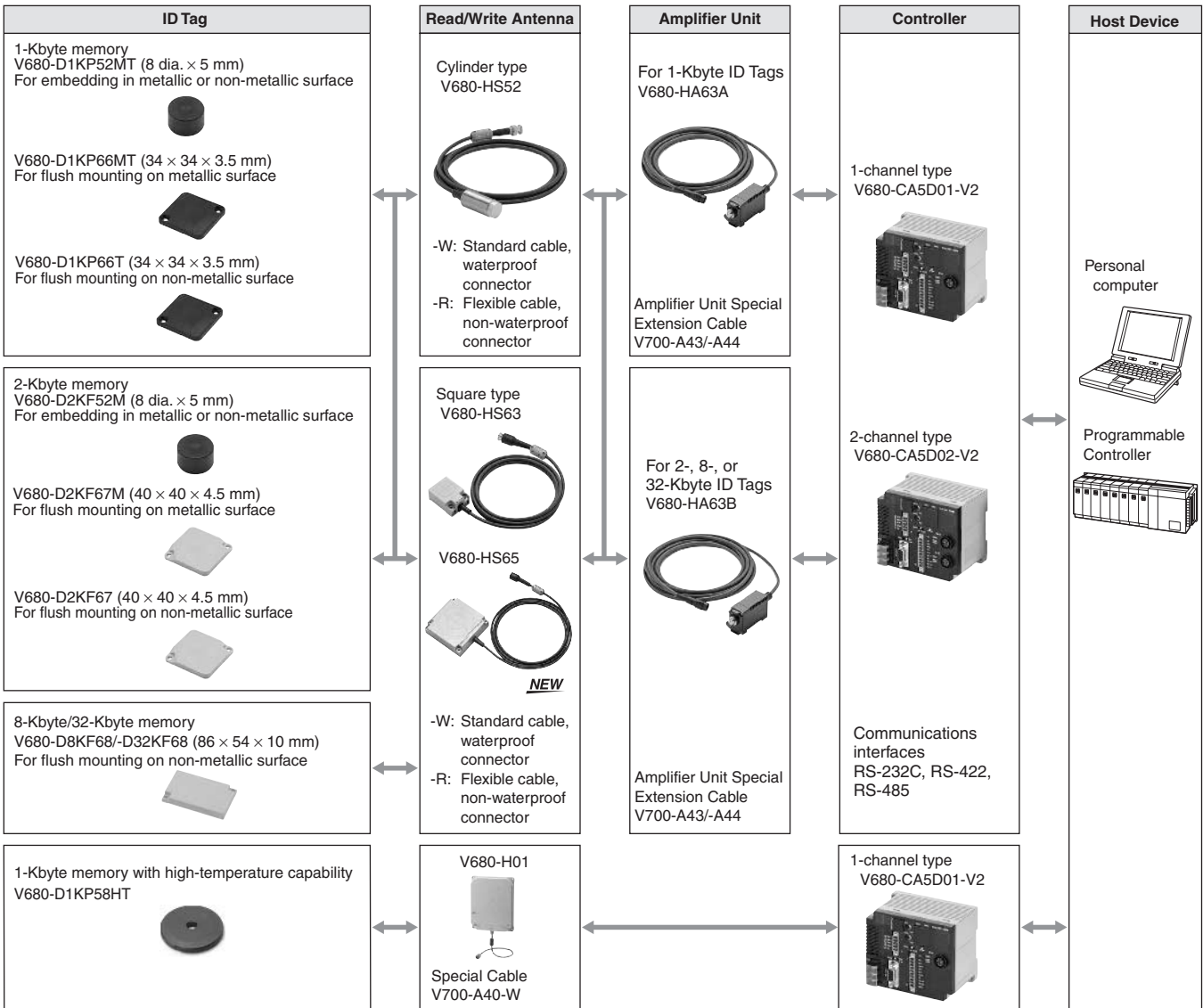



## System Configuration





# Ordering Information

## ID Tag

Type	Memory capacity	Appearance	Size	Metallic compatibility	Model
Battery-less	1 Kbyte		Cylindrical, ultra-compact 8 dia. × 5 mm	For embedding in metallic or non-metallic surface	V680-D1KP52MT
			Square 34 × 34 × 3.5 mm	For flush mounting on metallic surface	V680-D1KP66MT
				For flush mounting on non-metallic surface	V680-D1KP66T
		8 dia. × t10 mm (High-temperature type)	For flush mounting on non-metallic surface	V680-D1KP58HT	
	2 Kbytes		Cylindrical, ultra-compact 8 dia. × 5 mm	For embedding in metallic or non-metallic surface	V680-D2KF52M
			Square 40 × 40 × 4.5 mm	For flush mounting on metallic surface	V680-D2KF67M
				For flush mounting on non-metallic surface	V680-D2KF67
	8 Kbytes		86 × 54 × 10 mm	For flush mounting on non-metallic surface	V680-D8KF68
	32 Kbytes				V680-D32KF68

## Read/Write Antenna (Detachable Amplifier Unit Type)



Type	Appearance	Size	Cable length	Model
Cylindrical		M22 × 65 mm	Standard cable, waterproof connector 2 m	V680-HS52-W 2M
			12.5 m	V680-HS52-W 12.5M
			Flexible cable, non-waterproof connector 2 m	V680-HS52-R 2M
			12.5 m	V680-HS52-R 12.5M
Square		40 × 53 × 23 mm	Standard cable, waterproof connector 2 m	V680-HS63-W 2M
			12.5 m	V680-HS63-W 12.5M
			Flexible cable, non-waterproof connector 2 m	V680-HS63-R 2M
			12.5 m	V680-HS63-R 12.5M
		100 × 100 × 30 mm	Standard cable, waterproof connector 2 m	V680-HS65-W 2M
			12.5 m	V680-HS65-W 12.5M
			Flexible cable, non-waterproof connector 2 m	V680-HS65-R 2M
			12.5 m	V680-HS65-R 12.5M

## Read/Write Antenna with Built-in Amplifier

Type	Appearance	Size	Cable length	Model
Square		250 × 200 × 35 mm	0.5 m (See note.)	V680-H01



**Note:** Use an Antenna Cable to connect the Read/Write Antenna to the Controller.  
The maximum cable length is 30.5 m.

## Amplifier Unit

Type	Appearance	Size	Cable length	Model
For 1-Kbyte memory		25 × 40 × 65 mm	5 m	V680-HA63A 5M
			10 m	V680-HA63A 10M
For 2-/8-/32-Kbyte memory			5 m	V680-HA63B 5M
			10 m	V680-HA63B 10M



**Note:** The maximum extendable cable length is 50 m (including the Amplifier Unit cable). The maximum number of V700-A43/-A44 Amplifier Unit Special Extension Cables that can be connected is two.

## Controller

Type	No. of connectable Amplifiers	Appearance	Size	Transmission interface	Model
DC power supply	Single		105 × 90 × 65 mm	RS232C, RS422/RS485	V680-CA5D01-V2
	Dual				V680-CA5D02-V2

## Accessories (Order Separately)

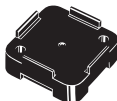
### ID Tag Attachment

Type	Appearance	Model
For the V680-D1KP66T		V600-A86
For the V680-D□KF68		V680-A81
To mount the V680-D1KP58HT		V680-A80

### Amplifier Unit Special Extension Cable (Amplifier Unit to Controller)

Cable length	Appearance	Model
10 m		V700-A43 10 M
20 m		V700-A44 20 M

### V680-H01 Read/Write Antenna Special Cable (Read/Write Antenna to Controller)

Cable length	Appearance	Model
2 m		V700-A40-W 2M
5 m		V700-A40-W 5M
10 m		V700-A40-W 10M
20 m		V700-A40-W 20M
30 m		V700-A40-W 30M

**Note:** The maximum cable length is 30.5 m. If extending the cable length, connect only one additional cable. (Do not connect more than two cables together.)

### RS-232C Communications Connector

Name	Model
Connector Plug	XM3B-0922-111
Connector Hood	XM2S-0911

### ID Map Manager

Type	Model
English version	V680-A-IMMEG-P01

**Note:** An RS422/RS485 Communications Connector is provided with the RFID System.

# Ratings and Performance

## ID Tag (1-Kbyte Memory)

Item	Model	V680-D1KP52MT	V680-D1KP66T	V680-D1KP66MT
Memory capacity		1,000 byte (user area)		
Memory type		EEPROM		
Data backup time		10 years after writing		
Memory longevity		100,000 times per block (at 25°C)		
Ambient operating temperature (during transmission)		-25 to 85°C (with no icing)		
Ambient operating temperature (not during transmission)		-40 to 125°C (with no icing) Heat resistance: 1,000 thermal cycles each of 30 minutes at -10°C/150°C, High-temperature storage: 1,000 hours at 150°C (See Note 1.) 200 thermal cycles each of 30 minutes at -10°C/180°C, High-temperature storage: 200 hours at 180°C (See Note 2.)		
Ambient storage temperature		-40 to 125°C (with no icing)		
Ambient operating humidity		35 to 95%		
Degree of protection		IEC 60529, IP68 In-house standard for antenna oil resistance (former JEM standard equivalent to IP67g) (See note 3.)		
Vibration resistance		10 to 2,000 Hz, 1.5-mm double amplitude at 150 m/s <sup>2</sup> acceleration with 10 sweeps in X, Y, and Z directions for 15 minutes each		
Shock resistance		500 m/s <sup>2</sup> in X, Y, and Z directions 3 times each (18 times in total)		
Appearance		8 dia. × 5 mm	34 × 34 × 3.5 mm	
Materials		Case: PPS resin Filling: Epoxy resin	Molding: PPS resin	
Weight		Approx. 0.5 g	Approx. 6 g	Approx. 7.5 g
Metallic compatibility		Yes	No	Yes

**Note 1.** 150°C heat resistance: The heat resistance has been checked at 150°C for up to 1,000 hours, and thermal shock has been checked through testing 1,000 thermal cycles each of 30 minutes at -10/150°C. (Test samples: 22, defects: 0)

**2.** 180°C heat resistance: The heat resistance has been checked at 180°C for up to 200 hours, and thermal shock has been checked through testing 200 thermal cycles each of 30 minutes at -10°C/180°C. (Test samples: 22, defects: 0)

**3.** This OMRON in-house standard confirms resistance to cutting and other oils. It is equivalent to the former JEM standard.

**4.** For details, refer to the *User's Manual* (Cat. No. Z262).

## ID Tag with 1-Kbyte Memory with High-temperature Capability

Item	Model	V680-D1KP58HT
Memory capacity		1,000 byte (user area)
Memory type		EEPROM
Data backup time		10 years after writing (See note.)
Memory longevity		100,000 times per block (at 85°C)
Ambient operating temperature (during transmission)		-10 to 85°C (with no icing)
Ambient operating temperature (not during transmission)		-40 to 110°C (with no icing) Heat resistance: 2,000 thermal cycles each of 30 minutes at room temperature/200°C (Refer to Heat Resistance, below, for details.)
Ambient storage temperature		-40 to 110°C (with no icing)
Ambient operating humidity		No limits.
Degree of protection		IEC 60529, IP67
Vibration resistance		10 to 2,000 Hz, 1.5-mm single amplitude at 150 m/s <sup>2</sup> acceleration with 10 sweeps in X, Y, and Z directions for 15 minutes each
Materials		PPS resin
Shock resistance		500 m/s <sup>2</sup> in X, Y, and Z directions 3 times each (18 times in total)
Weight		Approx. 90 g

**Note:** The data storage time at high temperatures (110 to 200°C) is 10 hours. Rewrite the data before 10 hours has lapsed.

## Heat Resistance

Sufficient heat resistance has been confirmed by evaluation testing comprising 2,000 thermal cycles each of 30 minutes at room temperature/200°C (Criterion: LTPD 10%).

The lifetime of the V680-D1KP58HT is affected by high-temperature storage, due to the effects of high temperatures on internal components. For details on the relationship between heat resistance and lifetime, refer to the *User's Manual* (Cat. No. Z221).

## ID Tag (2-Kbyte Memory)

Item	Model	V680-D2KF52M	V680-D2KF67	V680-D1KF67M
Memory capacity		2,000 bytes (user area)		
Memory type		FRAM		
Data backup time		10 years after writing (55°C or less)		
Memory longevity		10 billion times per block. Access frequency (See note 1.): 10 billion times		
Ambient operating temperature		-25 to 85°C (with no icing)		
Ambient storage temperature		-40 to 85°C (with no icing)		
Ambient operating humidity		35 to 95%	35 to 85%	
Degree of protection		IEC 60529, IP67		
Vibration resistance		10 to 2,000 Hz, 1.5-mm double amplitude at 150 m/s <sup>2</sup> acceleration with 10 sweeps in X, Y, and Z directions for 15 minutes each		
Shock resistance		500 m/s <sup>2</sup> in X, Y, and Z directions 3 times each (18 times in total)		
Appearance		8 dia. × 5 mm	40 × 40 × 4.5 mm	
Materials		Case: PPS resin Filling: Epoxy resin	Molding: ABS resin Filling: Epoxy resin	
Weight		Approx. 0.5 g	Approx. 6.5 g	Approx. 7 g
Metallic compatibility		Yes	No	Yes

**Note 1.** The total Read or Write communication frequency is called the access frequency.

**2.** For details, refer to the *User's Manual* (Cat. No. Z248).

## ID Tag with 8-/32-Kbyte Memory

Item	Model	V680-D8KF68	V680-D32KF68
Memory capacity		8,192 bytes (user area)	32,744 bytes (user area)
Memory type		FRAM	
Data backup time		10 years (at 70°C max.) or 6 years (at 85°C max.) after data is written	
Memory longevity		10 billion times per block at 85°C max. Access frequency (See note 1.): 10 billion times	
Ambient operating temperature		-20 to 85°C (with no icing)	
Ambient storage temperature		-40 to 85°C (with no icing)	
Ambient operating humidity		35 to 85%	
Degree of protection		IEC 60529, IP67 In-house standard for antenna oil resistance (former JEM standard equivalent to IP67g) (See note 2.)	
Vibration resistance		10 to 500 Hz, 1.5-mm double amplitude at 100 m/s <sup>2</sup> acceleration with 10 sweeps in X, Y, and Z directions for 11 minutes each	
Shock resistance		500 m/s <sup>2</sup> in X, Y, and Z directions 3 times each (18 times in total)	
Dimensions		86 × 54 × 10 mm	
Materials		Case: PBT resin Filling: Epoxy resin	
Weight		Approx. 50 g	
Metallic compatibility		No	

**Note 1.** The total Read or Write communication frequency is called the access frequency.

**2.** This OMRON in-house standard confirms resistance to cutting and other oils. It is equivalent to the former JEM standard.

**3.** For details, refer to the *User's Manual* (Cat. No. Z248).

### Cylindrical Read/Write Antenna (Detachable Amplifier Unit Type)

Item	Model	V680-HS52-W (Standard Cable, Waterproof Connector)	V680-HS52-R (Flexible Cable, Non-waterproof Connector)
Ambient operating temperature		-10 to 60°C (with no icing)	
Ambient storage temperature		-25 to 75°C (with no icing)	
Ambient operating humidity		35% to 95% (with no condensation)	
Insulation resistance		20 MΩ min. (at 500 VDC) between the cable terminals and the case	
Dielectric strength		1,000 VAC (50/60 Hz) for 1 minute between the cable terminals and the case with a current leakage of 5 mA max.	
Degree of protection		IP67 (IEC60529) In-house standard for antenna oil resistance (former JEM standard equivalent to IP67g) (Read/Write Antenna portion) (See note 1.)	IP67 (IEC60529) In-house standard for antenna oil resistance (former JEM standard equivalent to IP67g) (Read/Write Antenna portion) (See note 2.)
Vibration resistance		10 to 500 Hz variable vibration, 1.5-mm double amplitude at 100 m/s <sup>2</sup> acceleration, with 10 sweeps in X, Y, and Z directions for 8 minutes each	
Shock resistance		500 m/s <sup>2</sup> in X, Y, and Z directions 3 times each (18 times in total)	
Appearance		M22 × 65 mm	
Materials		ABS, brass, epoxy resin filling	
Weight		Approx. 850 g (with 12.5-m cable)	

**Note 1.** The degree of protection for the Connector is IP67/IP65. This OMRON in-house standard confirms resistance to cutting and other oils. It is equivalent to the former JEM standard.

**2.** The Connector is not waterproof. This OMRON in-house standard confirms resistance to cutting and other oils. It is equivalent to the former JEM standard.

**3.** For details, refer to the *User's Manual* (Cat. No. Z248 or Z262).

### Square Read/Write Antenna (Detachable Amplifier Unit Type)

Item	Model	V680-HS63-W (Standard Cable, Waterproof Connector)	V680-HS63-R (Flexible Cable, Non-waterproof Connector)
Ambient operating temperature		-10 to 60°C (with no icing)	
Ambient storage temperature		-25 to 75°C (with no icing)	
Ambient operating humidity		35% to 95% (with no condensation)	
Insulation resistance		20 MΩ min. (at 500 VDC) between the cable terminals and the case	
Dielectric strength		1,000 VAC (50/60 Hz) for 1 minute between the cable terminals and the case with a current leakage of 5 mA max.	
Degree of protection		IP67 (IEC60529) In-house standard for antenna oil resistance (former JEM standard equivalent to IP67g) (Read/Write Antenna portion) (See note 1.)	IP67 (IEC60529) In-house standard for antenna oil resistance (former JEM standard equivalent to IP67g) (Read/Write Antenna portion) (See note 2.)
Vibration resistance		10 to 500 Hz variable vibration, 1.5-mm double amplitude at 100 m/s <sup>2</sup> acceleration, with 10 sweeps in X, Y, and Z directions for 11 minutes each	
Shock resistance		500 m/s <sup>2</sup> in X, Y, and Z directions 3 times each (18 times in total)	
Appearance		40 × 53 × 23 mm	
Materials		ABS, epoxy resin filling	
Weight		Approx. 850 g (with 12.5-m cable)	

Item	Model	V680-HS65-W (Standard Cable, Waterproof Connector)	V680-HS65-R (Flexible Cable, Non-waterproof Connector)
Ambient operating temperature		-25 to 70°C (with no icing)	
Ambient storage temperature		-40 to 85°C (with no icing)	
Ambient operating humidity		35% to 95% (with no condensation)	
Insulation resistance		20 MΩ min. (at 500 VDC) between the cable terminals and the case	
Dielectric strength		1,000 VAC (50/60 Hz) for 1 minute between the cable terminals and the case with a current leakage of 5 mA max.	
Degree of protection		In-house standard for antenna oil resistance (former JEM standard equivalent to IP67g) (Read/Write Antenna portion) (See note 1.)	In-house standard for antenna oil resistance (former JEM standard equivalent to IP67g) (Read/Write Antenna portion) (See note 2.)
Vibration resistance		10 to 500 Hz variable vibration, 1.5-mm double amplitude at 100 m/s <sup>2</sup> acceleration, with 10 sweeps in X, Y, and Z directions for 11 minutes each	
Shock resistance		500 m/s <sup>2</sup> in X, Y, and Z directions 3 times each (18 times in total)	
Appearance		100 × 100 × 30 mm	
Materials		ABS, epoxy resin filling	
Weight		Approx. 1,100 g (with 12.5-m cable)	

**Note 1.** The degree of protection for the Connector is IP67/IP65. This OMRON in-house standard confirms resistance to cutting and other oils. It is equivalent to the former JEM standard.

**2.** The Connector is not waterproof. This OMRON in-house standard confirms resistance to cutting and other oils. It is equivalent to the former JEM standard.

**3.** For details, refer to the *User's Manual* (Cat. No. Z248 or Z262).

## Square Read/Write Antenna with Built-in Amplifier

Item	Model	V680-H01
Ambient operating temperature		-10 to 55°C (with no icing)
Ambient storage temperature		-35 to 65°C (with no icing)
Ambient operating humidity		35% to 85% (with no condensation)
Ambient storage humidity		35% to 95% (with no condensation)
Insulation resistance		20 MΩ min. (at 100 VDC) between the back plate and the case
Dielectric strength		1,000 VAC (50/60 Hz) for 1 minute between the back plate and the case with a current leakage of 1 mA max.
Degree of protection		IEC 60529: IP63 (Mounting direction: Transmission surface facing up)
Vibration resistance		10 to 150 Hz variable vibration, 0.7-mm double amplitude with 4 sweeps in X, Y, and Z directions for 8 minutes each
Shock resistance		150 m/s <sup>2</sup> in X, Y, and Z directions 3 times each
Cable length		0.5 m (See note 1.)
Weight		Approx. 900 g

- Note 1.** Use an Antenna Cable to connect the Read/Write Antenna to the Controller.  
The maximum cable length is 30.5 m. If extending the cable length, connect only one additional cable. (Do not connect more than two cables together.)
- 2.** For details, refer to the *User's Manual* (Cat. No. Z221).

## Amplifier Unit

Item	Model	V680-HA63A	V680-HA63B
Ambient operating temperature		-10 to 55°C (with no icing)	
Ambient storage temperature		-25 to 65°C (with no icing)	
Ambient operating humidity		35% to 85% (with no condensation)	
Insulation resistance		20 MΩ min. (at 500 VDC) between the cable terminals and the case	
Dielectric strength		1,000 VAC (50/60 Hz) for 1 minute between the cable terminals and the case with a current leakage of 5 mA max.	
Degree of protection		IP40 (IEC60529) (See note 1.)	IP67/IP65 (IEC60529) (See note 2.)
Vibration resistance		10 to 500 Hz variable vibration, 1.5-mm double amplitude at 100 m/s <sup>2</sup> acceleration, with 10 sweeps in X, Y, and Z directions for 11 minutes each	
Shock resistance		500 m/s <sup>2</sup> in X, Y, and Z directions 3 times each (18 times in total)	
Appearance		25 × 40 × 65 mm (not including projections)	
Material		Polycarbonate (PC) resin	
Weight		Approx. 650 g (with 10-m cable)	
Cable length		5 m, 10 m (See note 3.)	
Transmittable ID Tags		1-Kbyte memory	2-, 8-, 32-Kbyte memory

- Note 1.** When connected to the V680-HS63-R or V680-HS52-R.
- 2.** When connected to the V680-HS63-W or V680-HS52-W. (Not including the Connector on the Controller.)
- 3.** The maximum extendable cable length is 50 m (including the Amplifier Unit Cable). The maximum number of cables that can be connected is two.
- 4.** For details, refer to the *User's Manual* (Cat. No. Z248 or Z262).

**Controller**

Item	Model	V680-CA5D01-V2	V680-CA5D02-V2
Power supply voltage		24 VDC (-15% to +10%)	
Power consumption		15 W max., 0.8 A max.	
Ambient operating temperature		-10 to 55°C (with no icing)	
Ambient operating humidity		25% to 85% (with no condensation)	
Ambient storage temperature		-25 to 65°C (with no icing)	
Ambient storage humidity		25% to 85% (with no condensation)	
Insulation resistance		20 MΩ min. (at 500 VDC) applied as follows: (1) Between power supply terminals and grounded case (2) Between ground and terminals	
Dielectric strength		1,000 VAC (50/60 Hz) for 1 minute (1) Between power supply terminals and grounded case (2) Between ground and terminals	
Degree of protection		Panel mounted (equivalent to IP20)	
Vibration resistance		10 to 150 Hz variable vibration, 0.2-mm double amplitude at 15 m/s <sup>2</sup> acceleration, with 10 sweeps in X, Y, and Z directions for 8 minutes each	
Shock resistance		150 m/s <sup>2</sup>	
Appearance		105 × 90 × 65 mm (not including projections)	
Material		Polycarbonate (PC) resin, ABS resin	
Weight		Approx. 300 g	
Mounting method		DIN Track or M4 screws	
Connectable Amplifier Units		1	2

Note: For details, refer to the *User's Manual* (Cat. No. Z249).

**Transmission Specifications**

Item	Specifications	
	RS-232C	RS-422/RS-485
Connector specifications	9-pin D-Sub connector with threaded socket: M2.6	5-pin connector mfd. by Phoenix Contact: MC1.5/5GF-3.5
Transmission method	Half-duplex serial	4-wire/2-wire half-duplex serial
Transmission speed	9,600/19,200/38,400/115,200 bps	
Data length	7 or 8 bits	
Stop bit length	1 or 2 bits	
Error detection	Parity (even/odd/none)	
Cable length	15 m max.	500 m max.

**Input/Output Specifications**

**Input Specifications  
(RST, TRG1, TRG2)**

Input voltage	24 VDC (+10% to -15%, including ripple) (PNP and NPN compatible)
Input impedance	2.2 kΩ
Input current	10 mA TYP (24 VDC)
ON voltage	19 V min.
OFF voltage	5 V max.
Input response	70 ms max.

**Output Specifications  
(RUN, BUSY/OUT3, ERROR/OUT4, OUT1, OUT2)**

Maximum switching capacity	24 VDC (+10% to -15%, including ripple) 100-mA photoMOS output (PNP and NPN compatible)
Leakage current	100 μA max.
Residual voltage	2.0 V max.

- Note 1.** When RST input is ON, the CPU halts operation and the RST LED lights. The ERROR output is then reset.  
**2.** Short-circuiting in a no-load condition may cause transistor damage.

**USB Port**











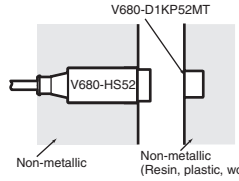

The USB port is used for a simple connection with a personal computer using a USB cable. The port complies with USB 1.1, and the USB cable uses a series A or series mini-B connector. A USB port driver must be separately provided. Consult with your OMRON representative for details. When connected to a host device via USB, the communications will use 1:1 protocol regardless of the setting of DIP switches 3 to 9. The USB port is not used for control purposes. When building a system, be sure to provide an RS-232C port or RS-422/ RS-485C port.

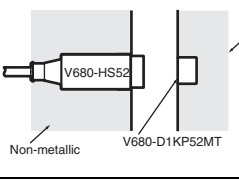

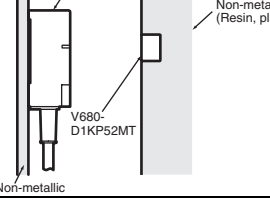

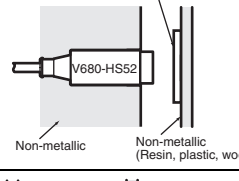

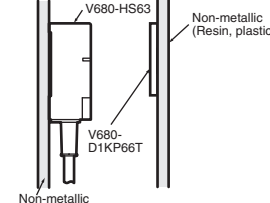

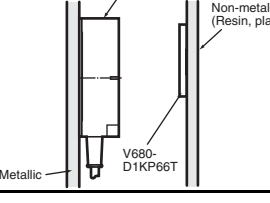
**System Configuration**

Connect V680 Read/Write Antennas and Amplifier Units to a V680-series Controller, and read or write data from or to V680-series ID Tags. Transmission is also possible with ID Tags other than those of the V680 Series as long as they comply with ISO/IEC 18000-3 (ISO/IEC 15693). However, transmission with ID Tags other than those of the V680 Series cannot be assured. The user must confirm transmission capabilities carefully prior to use.

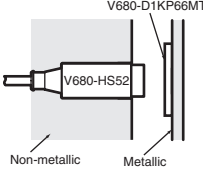
## ■ Performance Specifications

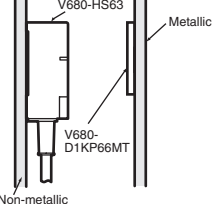

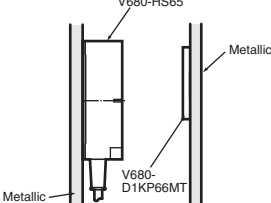

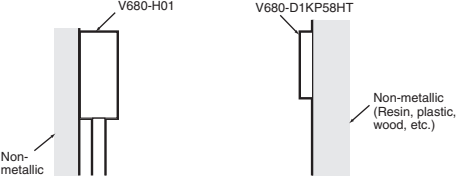







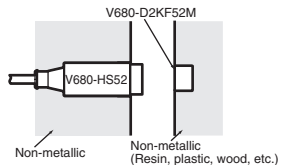

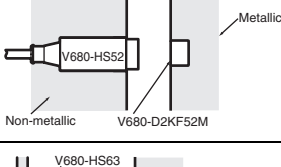

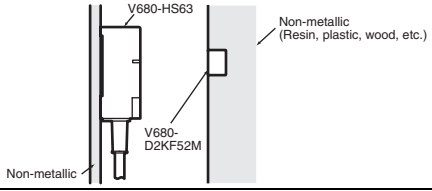

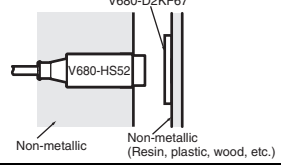
### ID Tag (1-kbyte Memory) Transmission

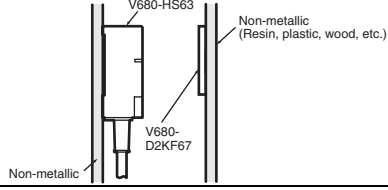
Recommended combination		Function	Transmission distance (unit: mm)	ID Tag and Read/Write Antenna mounting conditions
ID Tag	Read/Write Antenna			
V680-D1KP52MT 	V680-HS52 	Read distance	0 to 9.0 mm (axial deviation $\pm 2$ )	
		Write distance	0 to 8.5 mm (axial deviation $\pm 2$ )	
V680-D1KP52MT (embedded in metallic surface: steel) 	V680-HS52 	Read distance	0 to 4.5 mm (axial deviation $\pm 2$ )	
		Write distance	0 to 4.0 mm (axial deviation $\pm 2$ )	
V680-D1KP52MT 	V680-HS63 	Read distance	0 to 12.0 mm (axial deviation $\pm 2$ )	
		Write distance	0 to 9.5 mm (axial deviation $\pm 2$ )	
V680-D1KP66T 	V680-HS52 	Read distance	0 to 17.0 mm (axial deviation $\pm 2$ ) (See note.)	
		Write distance	0 to 17.0 mm (axial deviation $\pm 2$ ) (See note.)	
	V680-HS63 	Read distance	0 to 30.0 mm (axial deviation $\pm 10$ ) (See note.)	
		Write distance	0 to 25.0 mm (axial deviation $\pm 10$ ) (See note.)	
	V680-HS65 	Read distance	0 to 47.0 mm (axial deviation $\pm 10$ ) (See note.)	
		Write distance	0 to 42.0 mm (axial deviation $\pm 10$ )	

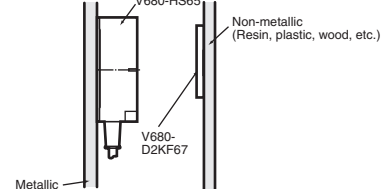

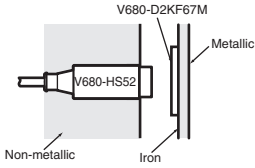

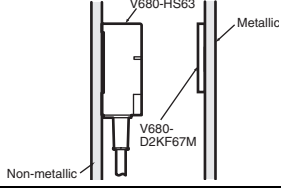

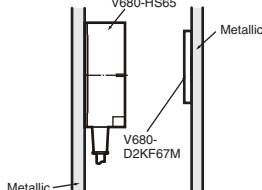

Recommended combination		Function	Transmission distance (unit: mm)	ID Tag and Read/Write Antenna mounting conditions
ID Tag	Read/Write Antenna			
		Read distance	0 to 16.0 mm (axial deviation $\pm 2$ )	
		Write distance	0 to 14.0 mm (axial deviation $\pm 2$ )	
		Read distance	0 to 25.0 mm (axial deviation $\pm 10$ )	
		Write distance	0 to 20.0 mm (axial deviation $\pm 10$ )	
		Read distance	0 to 25.0 mm (axial deviation $\pm 10$ )	
		Write distance	0 to 20.0 mm (axial deviation $\pm 10$ )	
		Read distance	0 to 150 mm (See note.)	
		Write distance		

**Note:** The transmission distance may be reduced if the V680-D1KP66T or V680-D1KP58HT is mounted onto a metallic surface. Refer to the *User's Manual* (V680-D1KP□□: Cat. No. Z262, V680-D1KP58HT: Cat. No. Z221) for details.

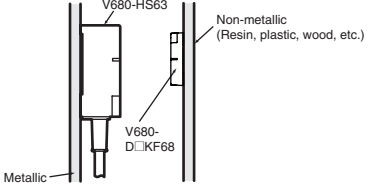
**ID Tag (2-kbyte Memory) Transmission**

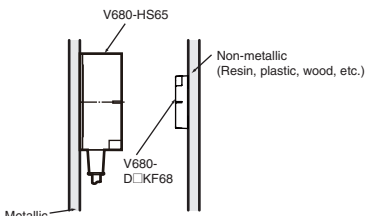
Recommended combination		Function	Transmission distance (unit: mm)	ID Tag and Read/Write Antenna mounting conditions
ID Tag	Read/Write Antenna			
V680-D2KF52M 	V680-HS52 	Read distance	0 to 8.0 mm (axial deviation ±2)	
		Write distance	0 to 8.0 mm (axial deviation ±2)	
V680-D2KF52M (embedded in metallic surface: steel) 	V680-HS52 	Read distance	0 to 3.0 mm (axial deviation ±2)	
		Write distance	0 to 3.0 mm (axial deviation ±2)	
V680-D2KF52M 	V680-HS63 	Read distance	0 to 9.5 mm (axial deviation ±2)	
		Write distance	0 to 9.5 mm (axial deviation ±2)	
V680-D2KF67 	V680-HS52 	Read distance	0 to 17.0 mm (axial deviation ±2) (See note.)	
		Write distance	0 to 17.0 mm (axial deviation ±2) (See note.)	
	V680-HS63 	Read distance	7 to 30.0 mm (axial deviation ±10) (See note.)	
		Write distance	7 to 30.0 mm (axial deviation ±10) (See note.)	
	V680-HS65 	Read distance	0 to 42.0 mm (axial deviation ±10) (See note.)	
		Write distance	0 to 42.0 mm (axial deviation ±10) (See note.)	
V680-D2KF67M (flush-mounted on metallic surface: steel) 	V680-HS52 	Read distance	0 to 16.0 mm (axial deviation ±2)	
		Write distance	0 to 16.0 mm (axial deviation ±2)	
	V680-HS63 	Read distance	6 to 25.0 mm (axial deviation ±10)	
		Write distance	6 to 25.0 mm (axial deviation ±10)	
	V680-HS65 	Read distance	0 to 25.0 mm (axial deviation ±10)	
		Write distance	0 to 25.0 mm (axial deviation ±10)	

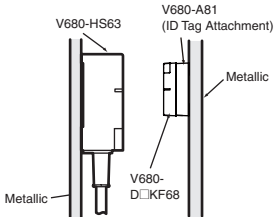
### ID Tag (8-/32-Kbyte Memory) Transmission

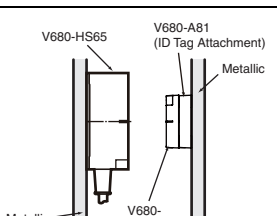
Recommended combination		Function	Transmission distance (unit: mm)	ID Tag and Read/Write Antenna mounting conditions
ID Tag	Read/Write Antenna			
		Read distance	0 to 45.0 mm (axial deviation ±10) (See note.)	
		Write distance	0 to 45.0 mm (axial deviation ±10) (See note.)	
		Read distance	0 to 75.0 mm (axial deviation ±10) (See note.)	
		Write distance	0 to 75.0 mm (axial deviation ±10) (See note.)	
		Read distance	0 to 35.0 mm (axial deviation ±10)	
		Write distance	0 to 35.0 mm (axial deviation ±10)	
		Read distance	0 to 55.0 mm (axial deviation ±10)	
		Write distance	0 to 55.0 mm (axial deviation ±10)	

**Note:** The transmission distance may be reduced if the V680-D□KF68 is mounted onto a metallic surface. Refer to the *User's Manual* (Cat. No. Z248) for details.

## Characteristic Data (Typical)

### Transmission Range

(unit: mm)

#### 1-kbyte Memory ID Tag

V680-HS52 & V680-D1KP52MT

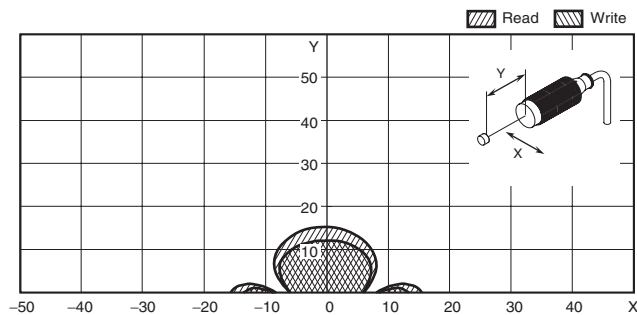

#### V680-HS52 & V680-D1KP52MT (embedded in metallic surface: steel)

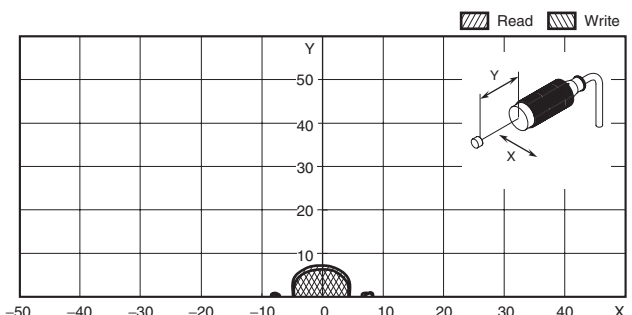

V680-HS63 & V680-D1KP52MT

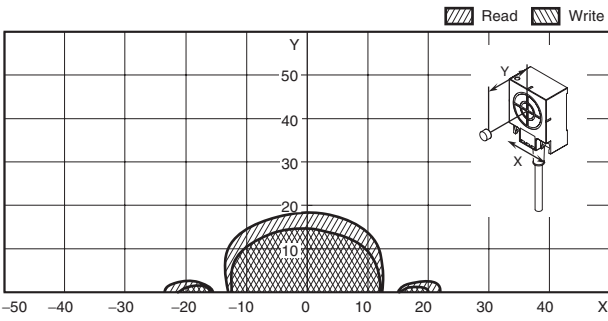

V680-HS63 & V680-D1KP66T

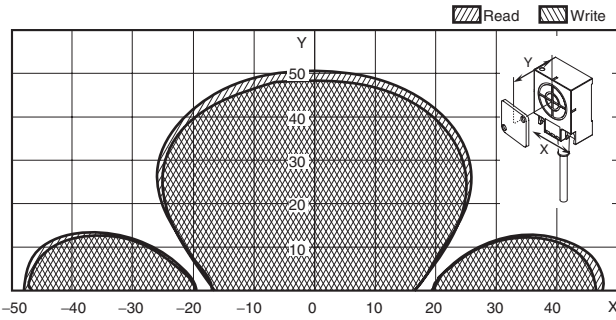

V680-HS52 & V680-D1KP66MT  
(flush-mounted on metallic surface: steel)

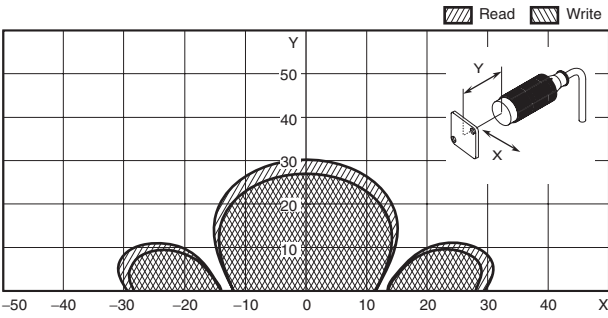

V680-HS65 & V680-D1K66MT  
(flush-mounted on metallic surface: steel)

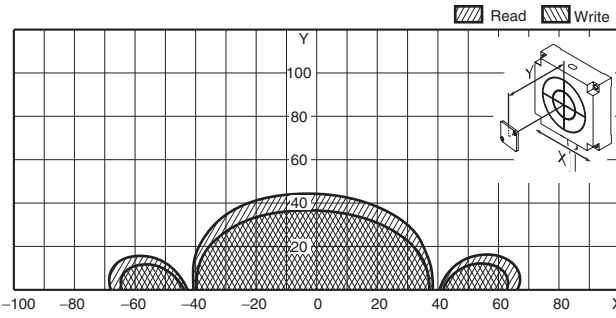

V680-HS52 & V680-D1KP66T

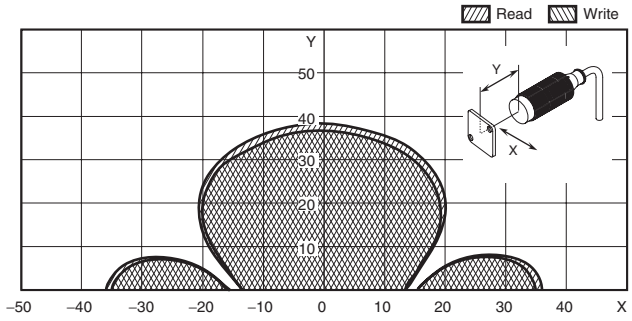

V680-HS65 & V680-D1KP66T

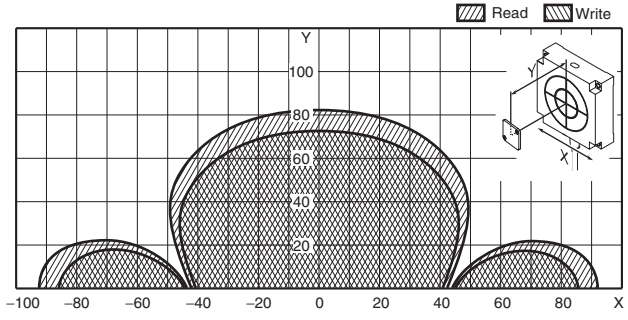

V680-HS63 & V680-D1KP66MT  
(flush-mounted on metallic surface: steel)

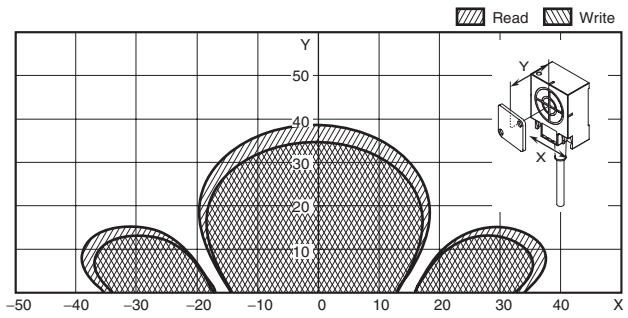

V680-H01 & V680-D1KP58HT

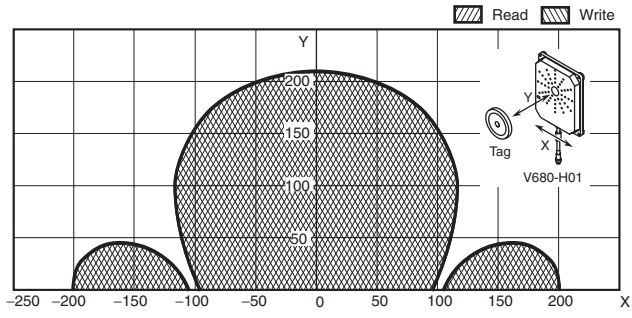

**2-kbyte Memory ID Tag**

V680-HS52 & V680-D2KF52M

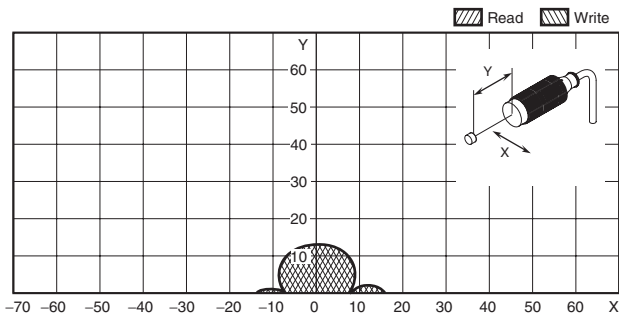

V680-HS63 & V680-D2KF52M

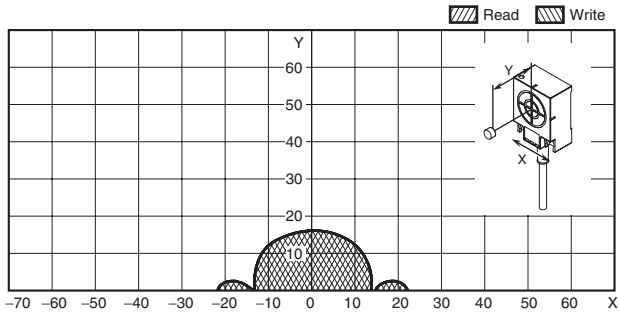

V680-HS52 & V680-D2KF67

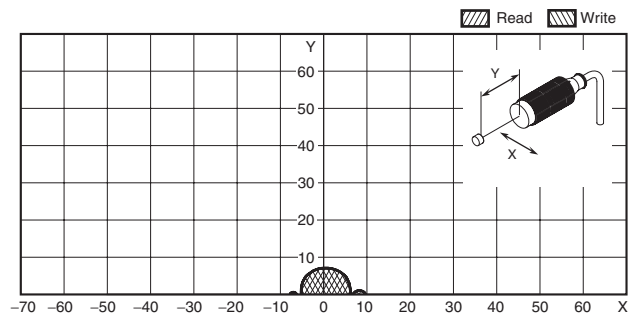

V680-HS65 & V680-D2KF67

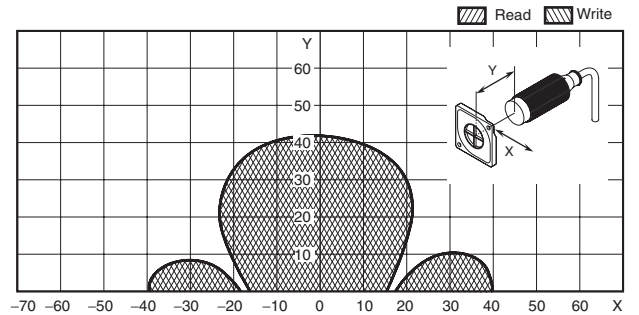

V680-HS52 & V680-D2KF67M

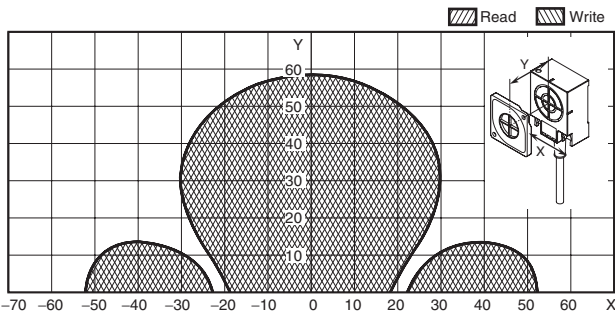

V680-HS63 & V680-D2KF67M

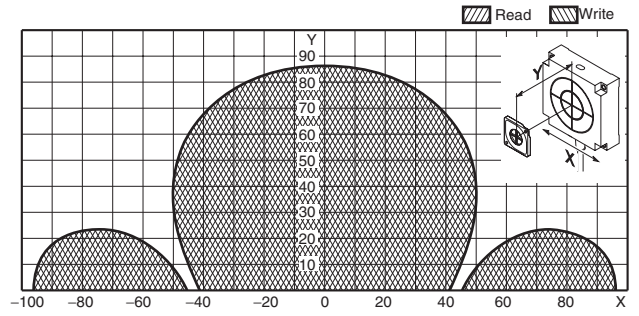

V680-HS65 & V680-D2KF67M

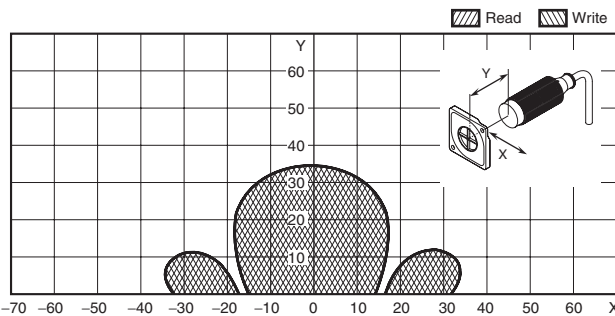

V680-HS65 & V680-D2KF67M

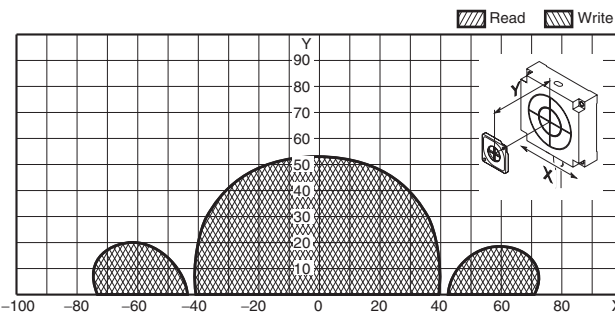
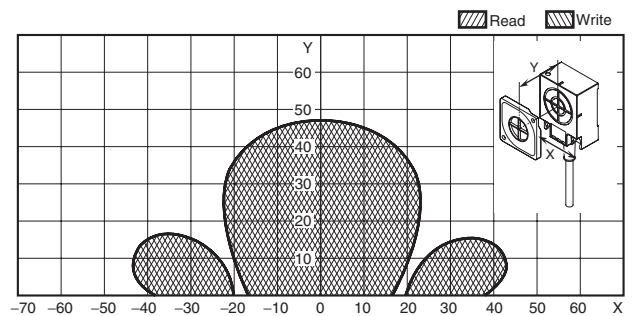

**8-/32-Kbyte Memory ID Tag**

**V680-HS63 & V680-D8KF68/-D32KF68**  
(Horizontal-facing ID Tag)

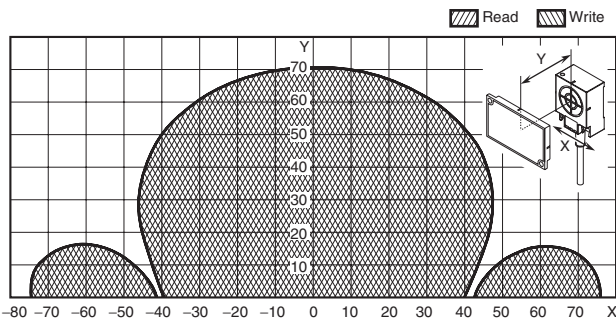

**V680-HS63 & V680-D8KF68/-D32KF68**  
Flush-mounted on metallic surface: steel (Horizontal-facing ID Tag) When the V680-A81 ID Tag Attachment is mounted.

**V680-HS63 & V680-D8KF68/-D32KF68**  
(Vertical-facing ID Tag)

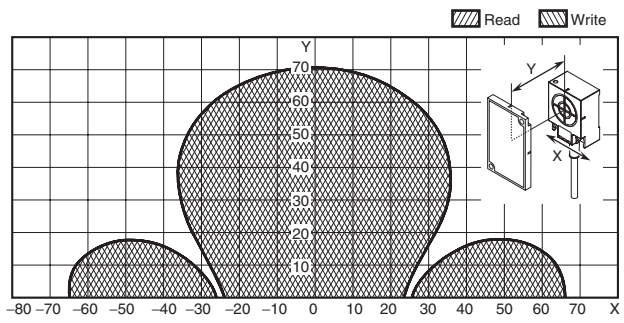

**V680-HS63 & V680-D8KF68/-D32KF68**  
Flush-mounted on metallic surface: steel (Vertical-facing ID Tag) When the V680-A81 ID Tag Attachment is mounted.

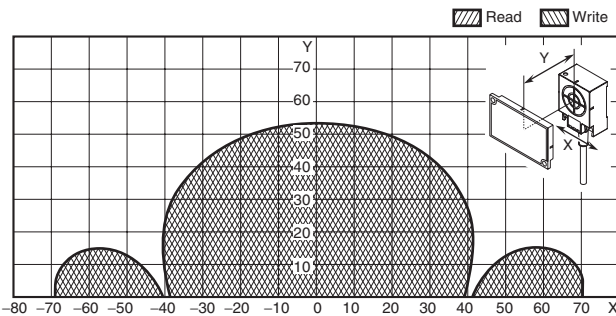

**V680-HS65 & V680-D8KF68/-D32KF68**  
(Horizontal-facing ID Tag)

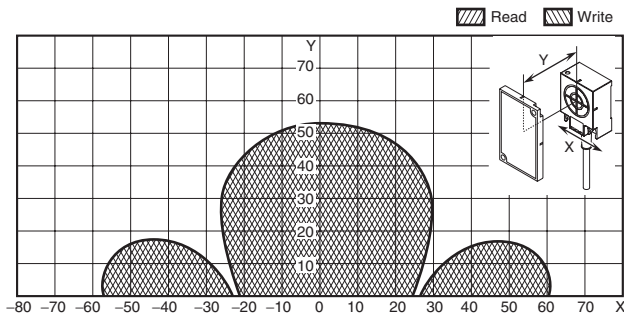

**V680-HS65 & V680-D8KF68/-D32KF68**  
(Vertical-facing ID Tag)

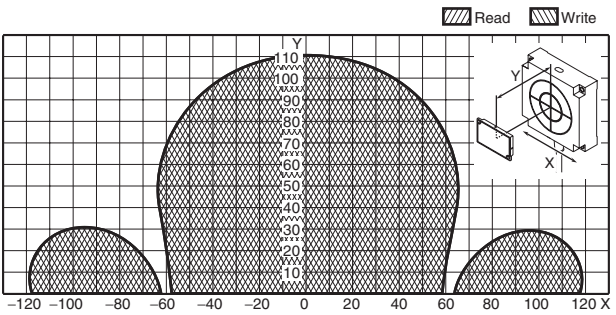

**V680-HS65 & V680-D8KF68/-D32KF68**  
Flush-mounted on metallic surface: steel (Horizontal-facing ID Tag) When the V680-A81 ID Tag Attachment is mounted.

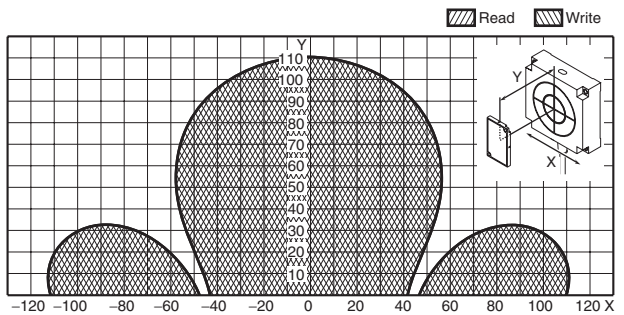

**V680-HS65 & V680-D8KF68/-D32KF68**  
Flush-mounted on metallic surface: steel (Vertical-facing ID Tag) When the V680-A81 ID Tag Attachment is mounted.

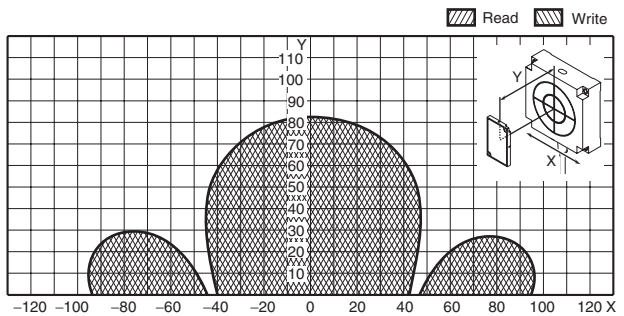
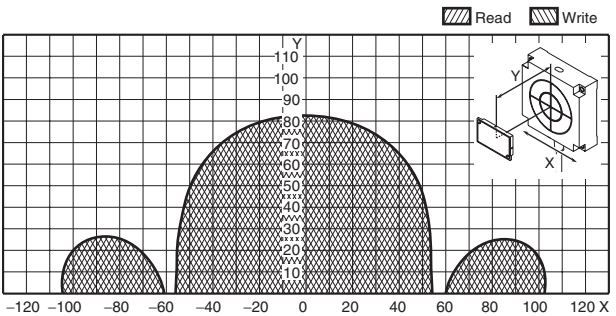

# ■ TAT and Communications Time (Reference)

## Communications Time

### 1-Kbyte Memory ID Tag

V680-D1KP□ (used in combination with the V680-HS□□ Read/Write Antenna and V680-HA63A Amplifier Unit)  
 V680-D1KP58HT (used in combination with the V680-H01 Read/Write Antenna)

● Transmission speed: Normal mode

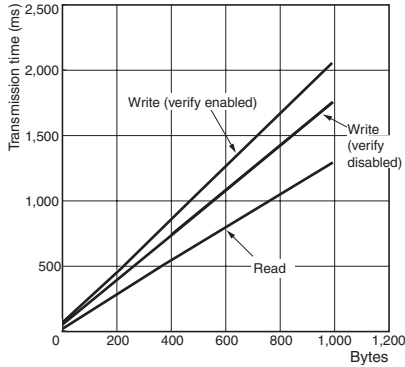

● Transmission speed: High-speed mode

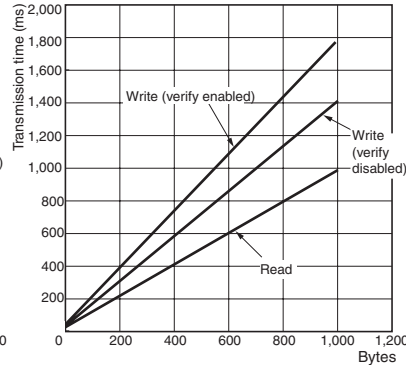

Controller transmission speed setting	Command	Write verification setting	Transmission time (ms) N = Number of processing bytes
Normal mode	Read	---	$T = 1.3N + 31$
	Write	Enabled	$T = 2.1N + 58$
		Disabled	$T = 1.8N + 56$
High-speed mode (See notes 1 and 2.)	Read	---	$T = 1.0N + 29$
	Write	Enabled	$T = 1.8N + 51$
		Disabled	$T = 1.5N + 47$

**Note 1.** The V680-H01 Read/Write Antenna cannot be used in high-speed mode.

**2.** When multi-access or FIFO is selected as the transmission option, the transmission time will be the same as in normal mode even when the transmission speed is set to high-speed mode.

### 2-Kbyte Memory ID Tag

V680-D2KF□□ (used in combination with the V680-HS□□ Read/Write Antenna and V680-HA63B Amplifier Unit)

● Transmission speed: Normal mode

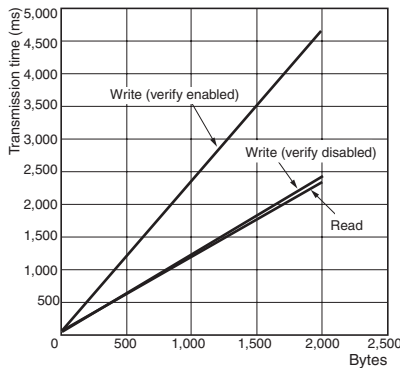

● Transmission speed: High-speed mode

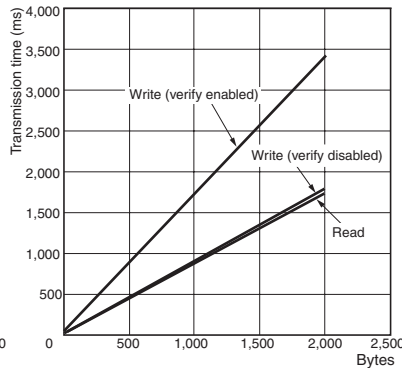

Controller transmission speed setting	Command	Write verification setting	Transmission time (ms) N = Number of processing bytes
Normal mode	Read	---	$T = 1.2N + 30$
	Write	Enabled	$T = 2.4N + 49$
		Disabled	$T = 1.2N + 49$
High-speed mode (See note.)	Read	---	$T = 0.9N + 27$
	Write	Enabled	$T = 1.7N + 49$
		Disabled	$T = 0.9N + 41$

**Note:** When multi-access or FIFO is selected as the transmission option, the transmission time will be the same as in normal mode even when the transmission speed is set to high-speed mode.

### 8-/32-Kbyte Memory ID Tag

V680-D8KF□□, V680-D32KF□□ (used in combination with the V680-HS□□ Read/Write Antenna and V680-HA63B Amplifier Unit)

● Transmission speed: Normal mode

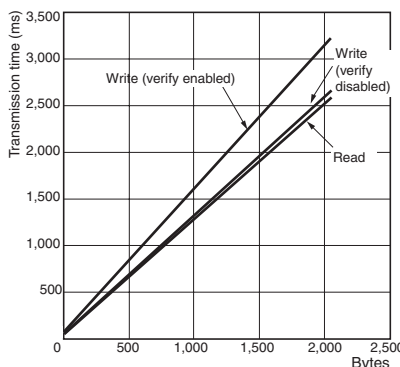

● Transmission speed: High-speed mode

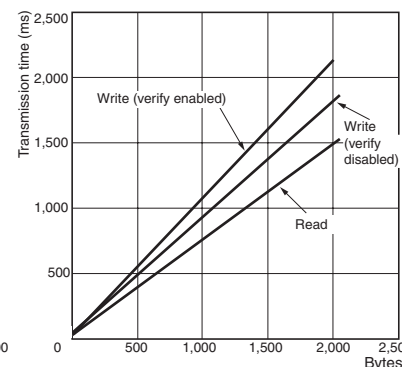

Controller transmission speed setting	Command	Write verification setting	Transmission time (ms) N = Number of processing bytes
Normal mode	Read	---	$T = 1.3N + 30$
	Write	Enabled	$T = 1.6N + 59$
		Disabled	$T = 1.3N + 50$
High-speed mode (See note.)	Read	---	$T = 0.8N + 25$
	Write	Enabled	$T = 0.9N + 40$
		Disabled	$T = 1.1N + 41$

**Note:** When multi-access or FIFO is selected as the transmission option, the transmission time will be the same as in normal mode even when the transmission speed is set to high-speed mode.

## TAT (Reference)

### TAT (Turn Around Time)

TAT refers to the total time required from the point at which a host device (such as a personal computer) starts sending a command until a response is received.

$$\text{TAT} = \text{Command send time} + \text{ID Tag transmission time} + \text{response receipt time}$$

Command send time: This is the time required for sending a command from the host device to the Controller.  
It varies depending on the communications speed and format.

ID Tag transmission time: This is the time required for transmission between the Read/Write Antenna and the ID Tag.

Response receipt time: This is the time required for returning a response from the Controller to the host device.  
It varies depending on the communications speed and format.

#### For an ordinary command



### 1-Kbyte Memory ID Tag

V680-D1KP□ (used in combination with the V680-HS□□ Read/Write Antenna and V680-HA63A Amplifier Unit)

V680-D1KP58HT (used in combination with the V680-H01 Read/Write Antenna)

Controller transmission speed setting	Command	Write verification setting	Number of bytes to processed (byte)	TAT (ms) (See note 1.)	
Normal mode	Read	---	100	173	
			256	389	
			512	747	
			1,000	1,431	
	Write	Enabled	Enabled	100	280
				256	621
				512	1,184
				1,000	2,258
		Disabled	Disabled	100	248
				256	542
				512	1,028
				1,000	1,956
High-speed mode (See notes 2 and 3.)	Read	---	100	141	
			256	310	
			512	591	
			1,000	1,129	
	Write	Enabled	Enabled	100	243
				256	537
				512	1,023
				1,000	1,951
		Disabled	Disabled	100	209
				256	456
				512	865
				1,000	1,647

**Note 1.** These are the TAT values for a baud rate of 115,200 bps. For information on the TAT for baud rates other than 115,200 bps, refer to the *User's Manual*.

**2.** The V680-H01 Read/Write Antenna cannot be used in high-speed mode.

**3.** When multi-access or FIFO is selected as the transmission option, the transmission time will be the same as in normal mode even when the transmission speed is set to high-speed mode.

**4.** The value given for TAT data assumes that communications settings for the V680-CA5D01/02-V2 ID Controller are as follows:  
Data length: 8 bits, Stop bits: 1, Parity: Odd.

In this example, communications are continuous, with no gaps between characters.

**5.** The number of bytes of TAT data is the number of bytes when ASCII is specified as the code.

## 2-Kbyte Memory ID Tag

V680-D2KF□□ (used in combination with the V680-HS□□ Read/Write Antenna and V680-HA63B Amplifier Unit)

Controller transmission speed setting	Command	Write verification setting	Number of bytes to processed (byte)	TAT (ms) (See note 1.)	
Normal mode	Read	---	100	162	
			256	363	
			512	695	
			1,000	1,330	
			2,000	2,620	
	Write	Enabled	Enabled	100	301
				256	689
				512	1,328
				1,000	2,549
				2,000	5,039
		Disabled	Disabled	100	181
				256	382
				512	714
				1,000	1,349
2,000				2,639	
High-speed mode (See note 2.)	Read	---	100	132	
			256	286	
			512	541	
			1,000	1,030	
			2,000	2,020	
	Write	Enabled	Enabled	100	231
				256	510
				512	970
				1,000	1,849
				2,000	3,639
		Disabled	Disabled	100	143
				256	297
				512	552
				1,000	1,041
2,000				2,031	

- Note 1.** These are the TAT values for a baud rate of 115,200 bps. For information on the TAT for baud rates other than 115,200 bps, refer to the *User's Manual*.
- 2.** When multi-access or FIFO is selected as the transmission option, the transmission time will be the same as in normal mode even when the transmission speed is set to high-speed mode.
- 3.** The value given for TAT data assumes that communications settings for the V680-CA5D01/02-V2 ID Controller are as follows:  
Data length: 8 bits, Stop bits: 1, Parity: Odd.  
In this example, communications are continuous, with no gaps between characters.
- 4.** The number of bytes of TAT data is the number of bytes when ASCII is specified as the code.

### 8-/32-Kbyte Memory ID Tag

V680-D8KF□□, V680-D32KF□□ (used in combination with the V680-HS□□ Read/Write Antenna and V680-HA63B Amplifier Unit)

Controller transmission speed setting	Command	Write verification setting	Number of bytes to processed (byte)	TAT (ms) (See note 1.)	
Normal mode	Read	---	100	172	
			256	388	
			512	746	
			1,000	1,430	
			2,000	2,820	
	Write	Yes		100	231
				256	494
				512	929
				1,000	1,759
				2,000	3,449
		No		100	192
				256	408
				512	766
				1,000	1,450
High-speed mode (See note 2.)	Read	---	100	117	
			256	255	
			512	485	
			1,000	925	
			2,000	1,815	
	Write	Yes		100	163
				256	348
				512	655
				1,000	1,241
				2,000	2,431
		No		100	142
				256	296
				512	551
				1,000	1,040
			2,000	2,030	

- Note 1.** These are the TAT values for a baud rate of 115,200 bps. For information on the TAT for baud rates other than 115,200 bps, refer to the *User's Manual*.
- 2.** When multi-access or FIFO is selected as the transmission option, the transmission time will be the same as in normal mode even when the transmission speed is set to high-speed mode.
- 3.** The value given for TAT data assumes that communications settings for the V680-CA5D01/02-V2 ID Controller are as follows:  
Data length: 8 bits, Stop bits: 1, Parity: Odd.  
In this example, communications are continuous, with no gaps between characters.
- 4.** The number of bytes of TAT data is the number of bytes when ASCII is specified as the code.

# Safety Precautions

## ⚠ WARNING

Do not use this product as a detection device to protect people.



**Note:** This catalog is intended only to help select the appropriate product. Be sure to read the User's Manual for usage precautions prior to using the product.

## Precautions for Safe Use

To ensure safety, be sure to follow the following precautions:

1. Do not operate this product in any flammable, explosive, or corrosive gas environment.
2. Do not disassemble, repair, or remodel this product.
3. Tighten the base lock screws and terminal block screws completely.
4. Be sure to use wiring crimp terminals of the specified size.
5. If any cable has a locking mechanism, be sure to check that it has been locked before using it.
6. The DC power supply must be within the specified rating (24 VDC +10%/–15%).
7. Do not reverse the power supply connection.
8. Do not insert water, wire, etc., into any of the gaps in the case. Doing so may cause fire or electric shock.
9. Turn OFF the Controller power before attaching or removing the Read/Write Antenna.
10. In the event that the product exhibits any abnormal condition, immediately stop using the system, turn OFF the power, and contact your OMRON sales representative.
11. Dispose of this product as industrial waste.
12. Be sure to follow any other warnings, cautions, and notices given in this document.

## Precautions for Correct Use

Please observe the following precautions to prevent failure to operate, malfunctions, or undesirable effects on product performance.

### Installation Site

Install the product at a location where:

- It is not exposed to corrosive gases, dust, metal chips, or salt.
- The ambient operating temperature is within the range stipulated in the specifications.
- There are no sudden variations in temperature (no condensation).
- The ambient operating humidity is within the range stipulated in the specifications.
- No vibration or shock exceeding the values stipulated in the specifications is transmitted directly to the body of the product.
- It is not subject to splashing water, oil, or chemical substances.

### Installation

- The product uses the 13.56-MHz frequency band to communicate with ID Tags. Some devices, such as some motors, inverters, and switching power supplies, generate electromagnetic waves (i.e., noise) that can affect communications with ID Tags. If any of these devices are nearby, communications with ID Tags may be affected or ID Tags may be destroyed. If the product is to be used near such devices, check the effects on communications before using the product.
- To minimize the general influence of noise, observe the following precautions:
  1. Ground any metallic material located around this device to 100 Ω or less.
  2. Keep the product away from high voltage and heavy current.
- Do not use products that are not waterproof in misty environments.
- Do not subject the products to chemicals that adversely affect product materials.
- When installing the product, tighten screws to the following torque:
 

Controller:	1.2 N·m max.
V680-HS63 Read/Write Antenna:	1.2 N·m
V680-HS52 Read/Write Antenna:	40 N·m
V680-HS65 Read/Write Antenna:	1.2 N·m
- When Read/Write Antennas are mounted side-by-side, mutual interference may reduce the transmission performance. Refer to the *RFID System Amplifier and Antennas/ID Tags User's Manual* to mount them in a way that will prevent mutual interference.

### Storage

Store the product at a location where:

- It is not exposed to corrosive gases, dust, metal chips, or salt.
- The ambient storage temperature is within the range stipulated in the specifications.
- There are no sudden variations in temperature (no condensation).
- The ambient storage humidity is within the range stipulated in the specifications.
- No vibration or shock exceeding the values stipulated in the specifications is transmitted directly to the body of the product.
- It is not subject to splashing water, oil, or chemical substances.

### Cleaning

Do not use thinner, benzene, acetone, or kerosene for cleaning. Using these substances may dissolve the resin material and the case.

# Dimensions

Note: All units are in millimeters unless otherwise indicated.

## ID Tag

### V680-D1KP52MT

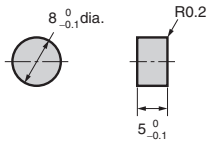

Case material	PPS resin
Filling	Epoxy resin

### V680-D1KP66T/-D1KP66MT

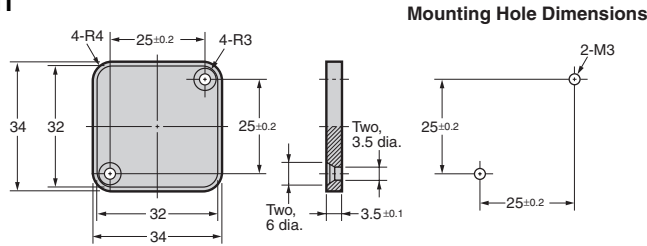

Case material	PPS resin
---------------	-----------

### V680-D2KF52M

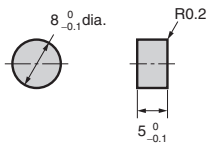

Case material	PPS resin
Filling	Epoxy resin

### V680-D2KF67/-D2KF67M

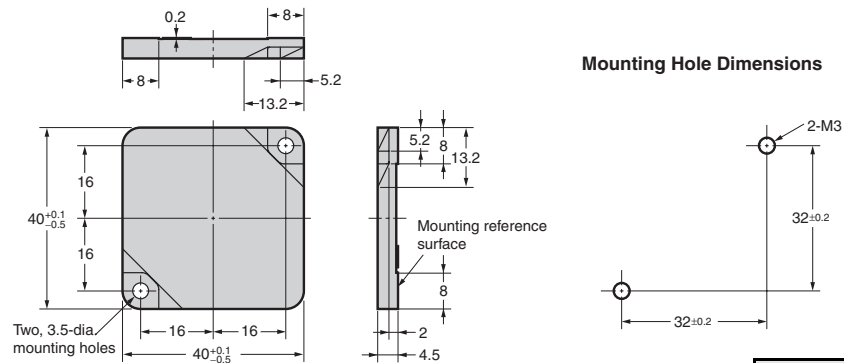

Case material	ABS resin
Filling	Epoxy resin

### V680-D8KF68/-D32KF68

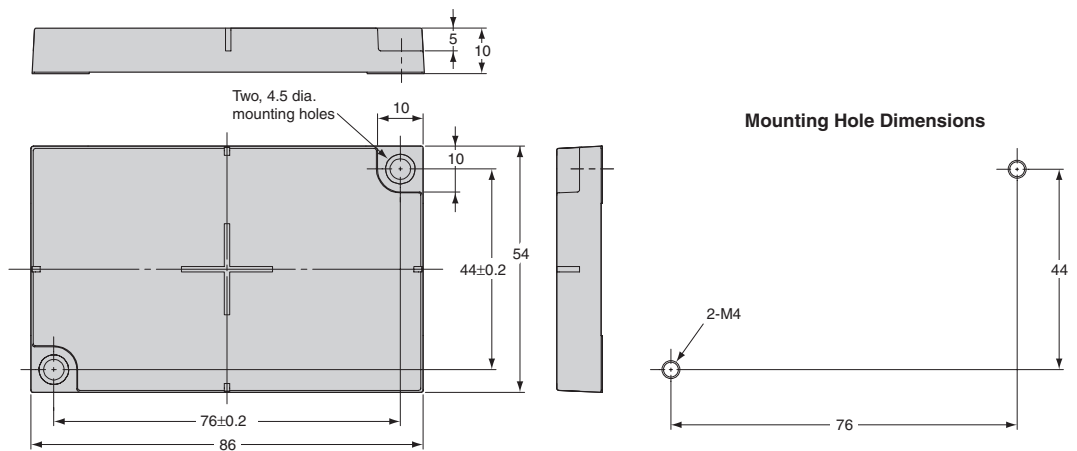

Case material	PBT resin
Filling	Epoxy resin

V680-D1KP58HT

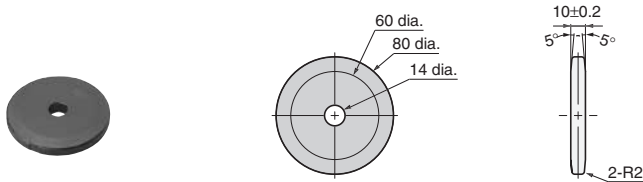

Read/Write Antenna with Detachable Amplifier Unit

V680-HS52-W

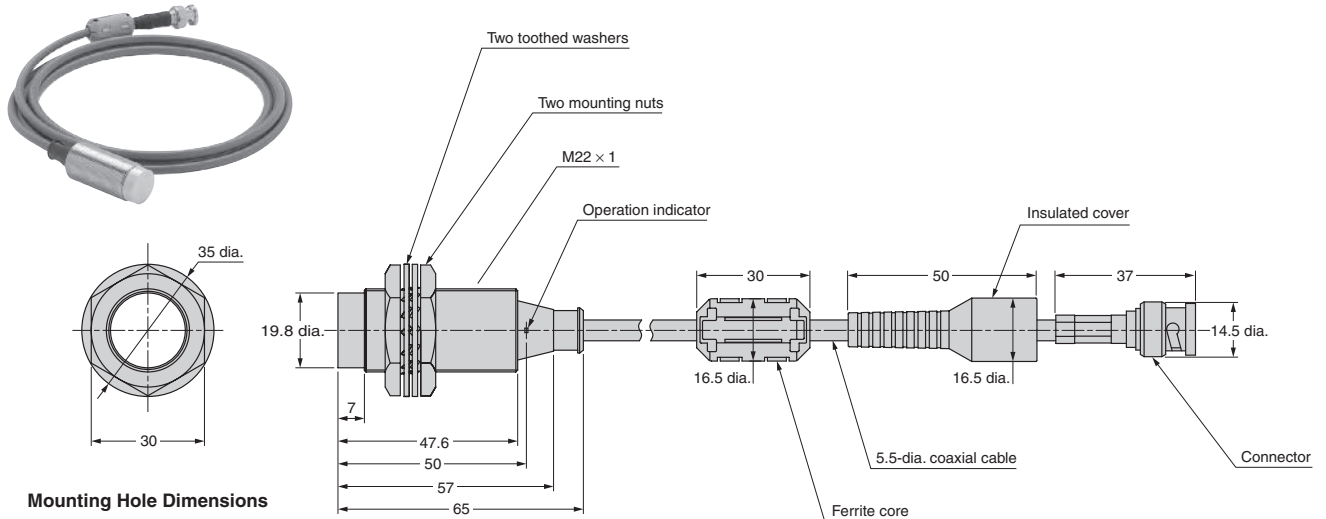

Mounting Hole Dimensions

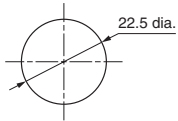

<b>Case material</b>	Brass
<b>Transmission surface</b>	PBT resin
<b>Filling</b>	Epoxy resin
<b>Cable</b>	PVC
<b>Cable length</b>	2M/12.5M

V680-HS52-R

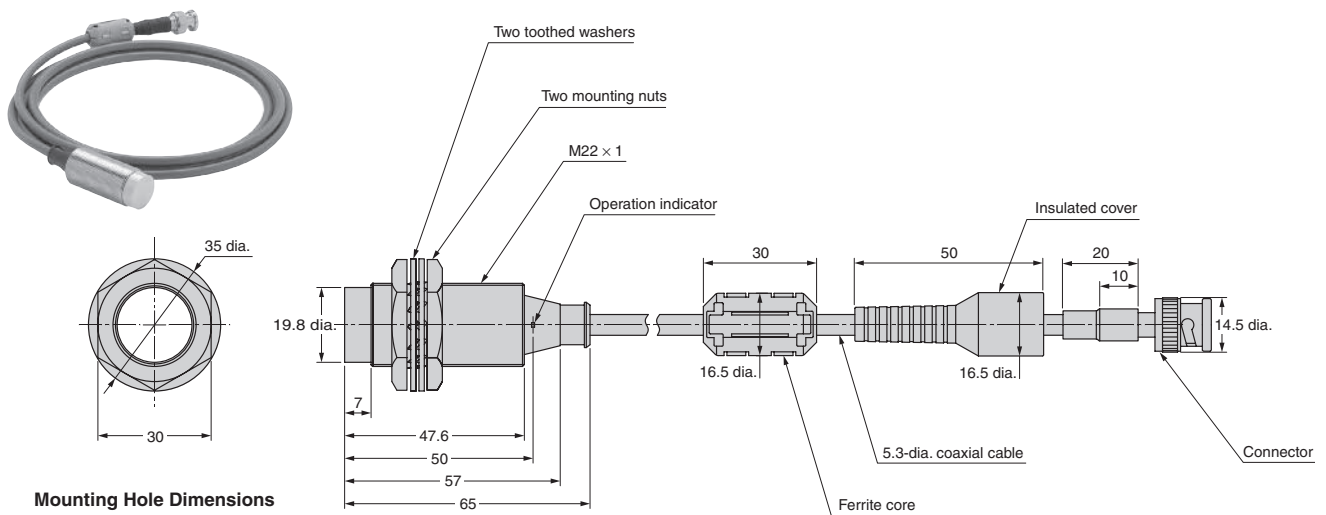

Mounting Hole Dimensions

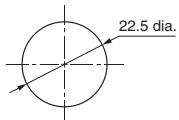

<b>Case material</b>	Brass
<b>Transmission surface</b>	PBT resin
<b>Filling</b>	Epoxy resin
<b>Cable</b>	PVC
<b>Cable length</b>	2M/12.5M

V680-HS63-W

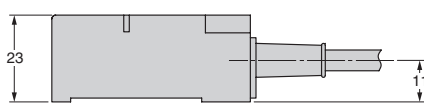
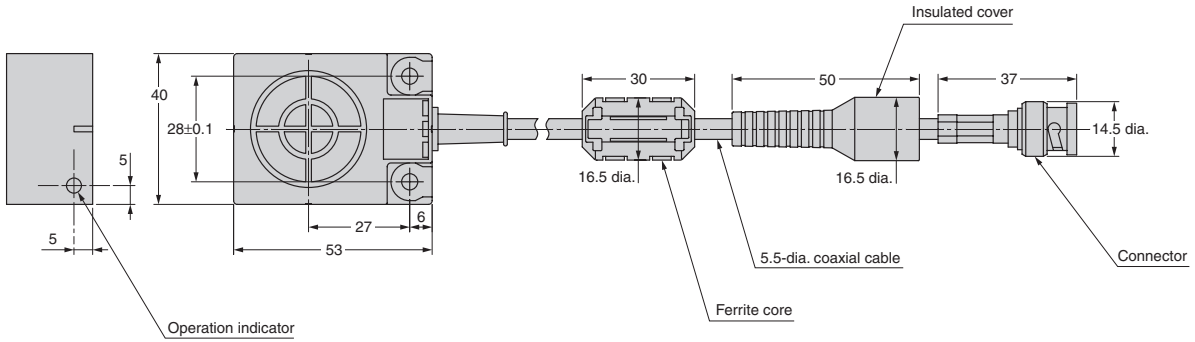

Mounting Hole Dimensions

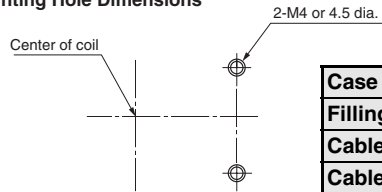

Case material	ABS resin
Filling	Epoxy resin
Cable	PVC
Cable length	2M/12.5M

V680-HS63-R

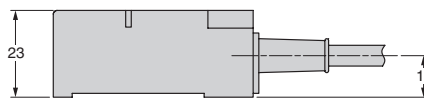
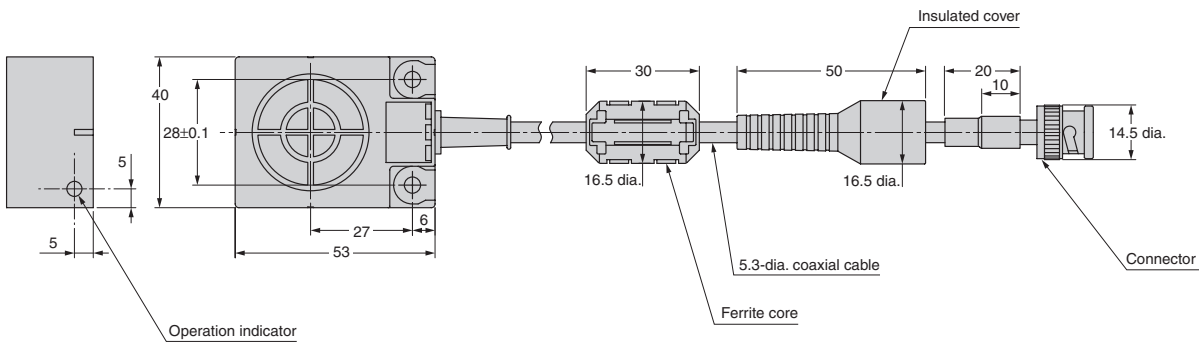

Mounting Hole Dimensions

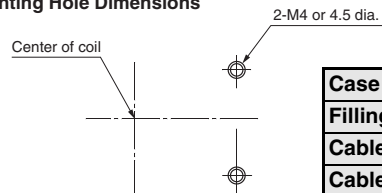

Case material	ABS resin
Filling	Epoxy resin
Cable	PVC
Cable length	2M/12.5M

V680-HS65-W

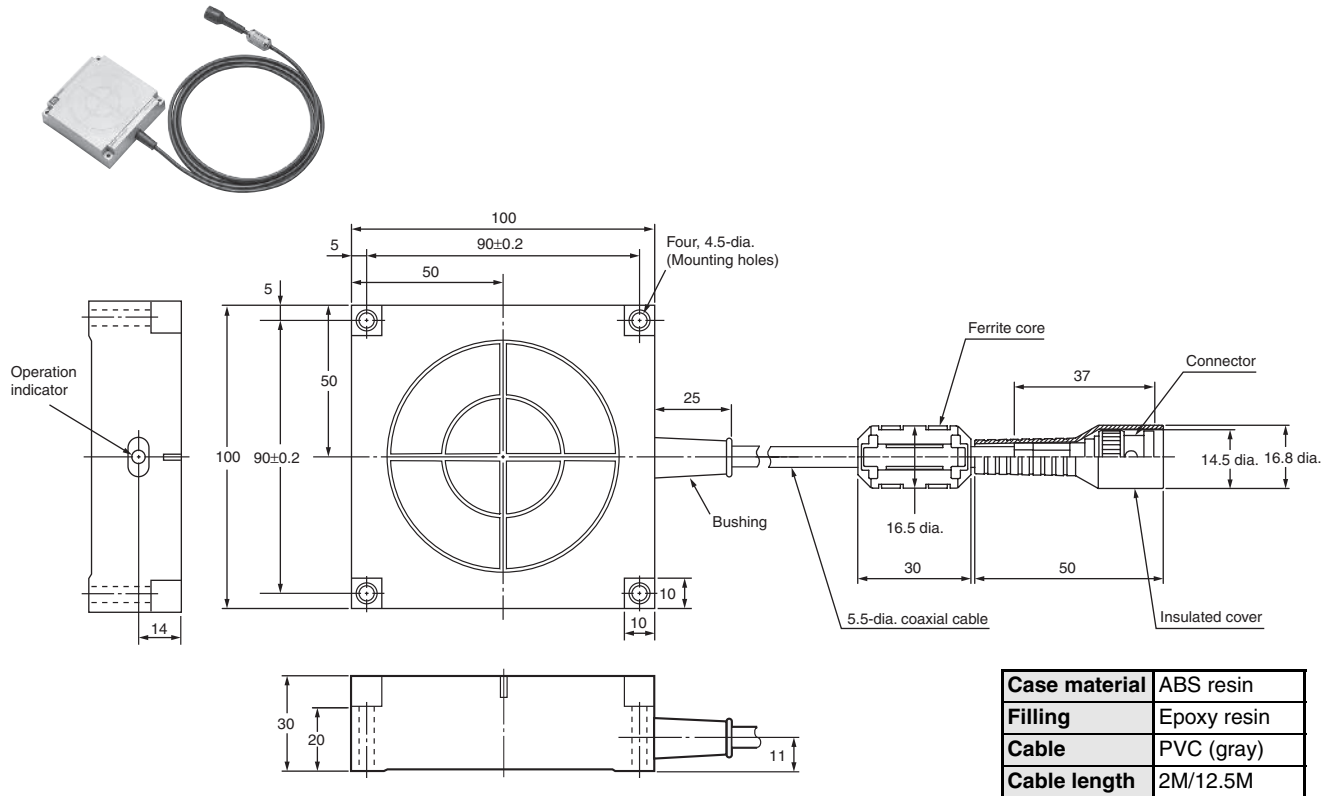

V680-HS65-R

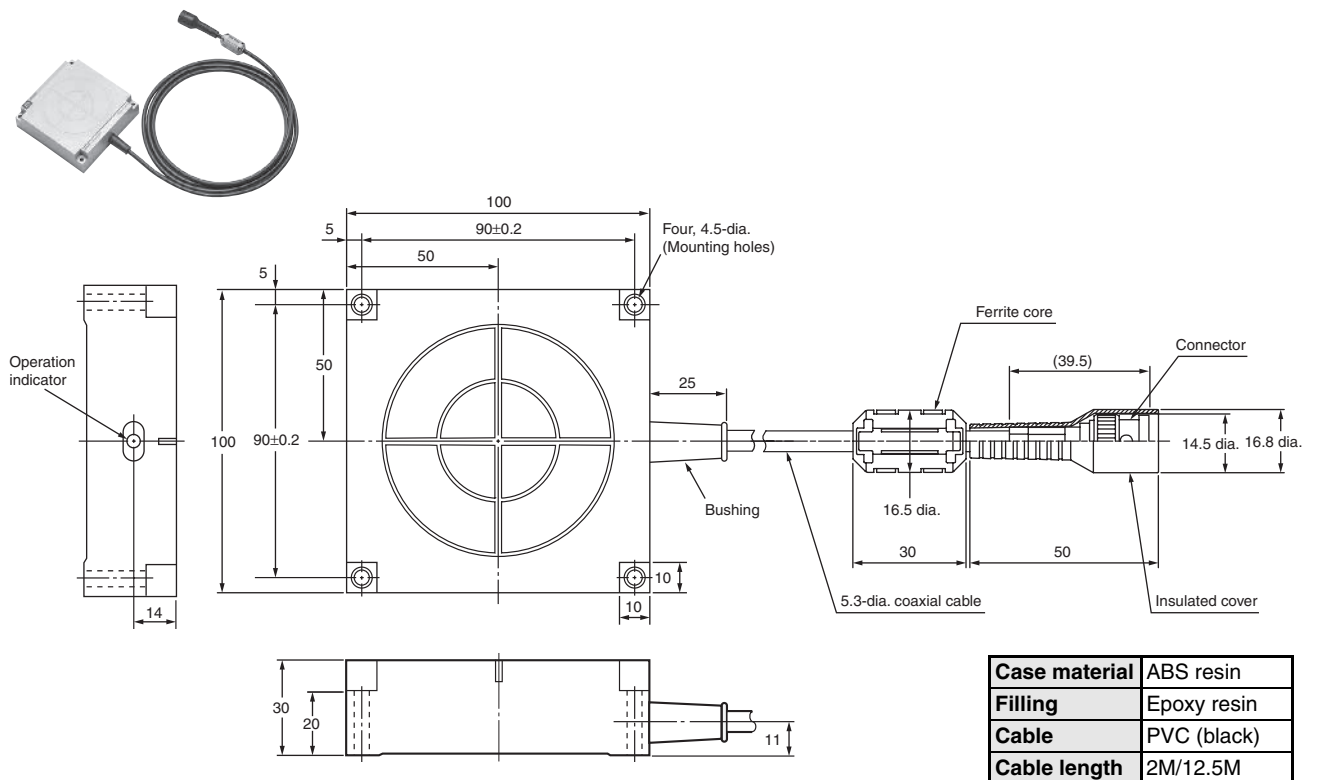

Read/Write Antenna with Built-in Amplifier Unit

V680-H01

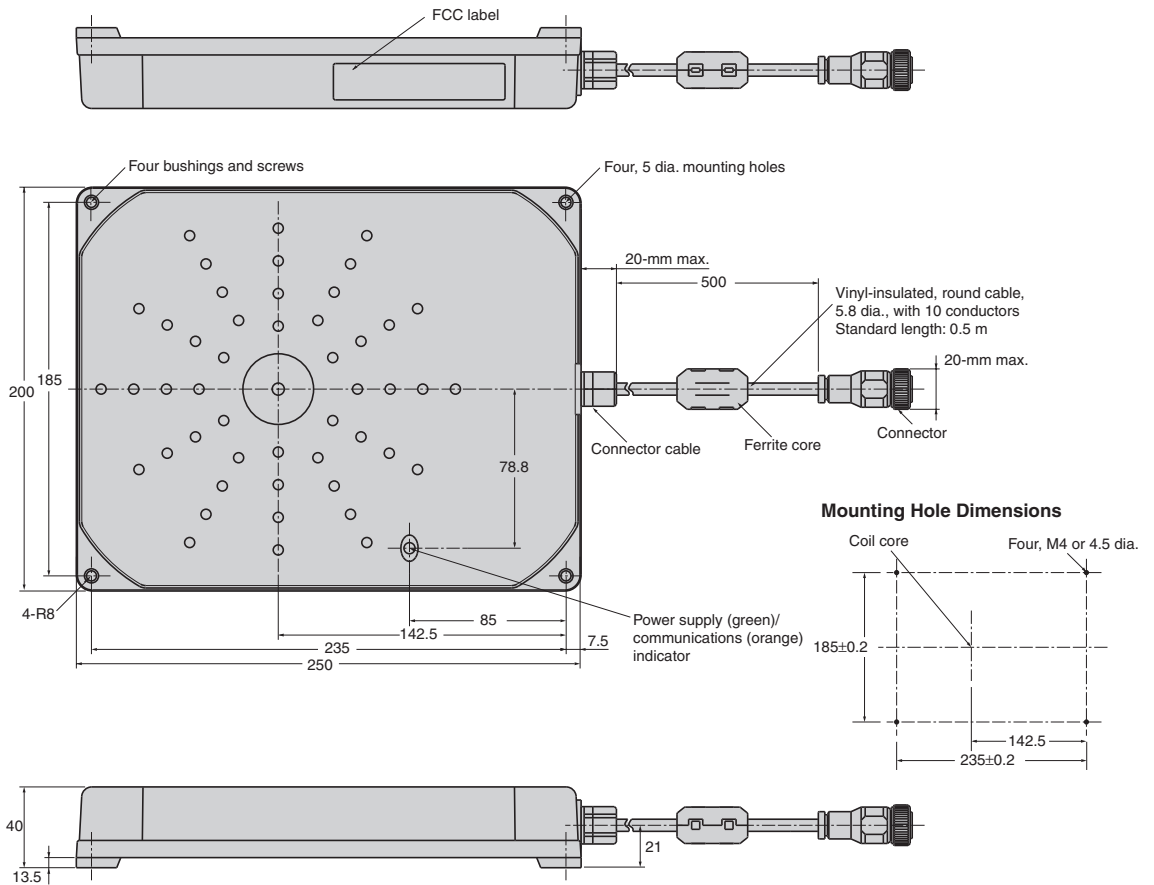

<b>Case material</b>	PC/ASA resin
<b>Filling</b>	Aluminum
<b>Cable</b>	PVC

### Amplifier Unit

V680-HA63A/HA63B

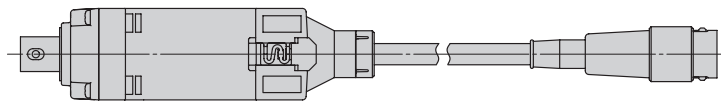
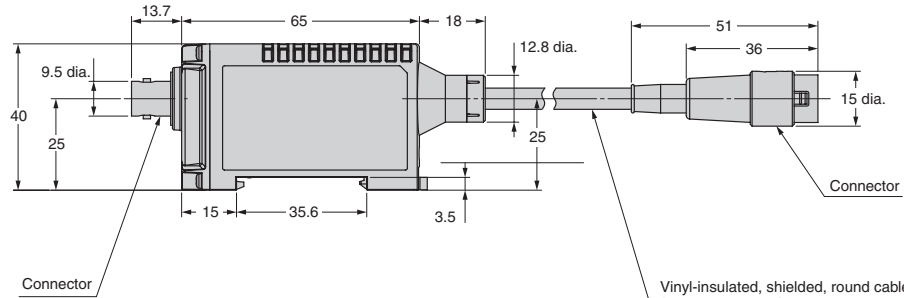
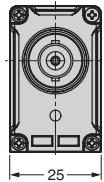
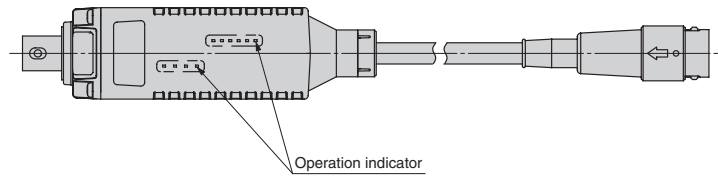

Case material	PC resin
Filling	Epoxy resin
Cable	PVC
Cable length	5M/10M

### ID Controller

V680-CA5D01-V2/CA5D02-V2

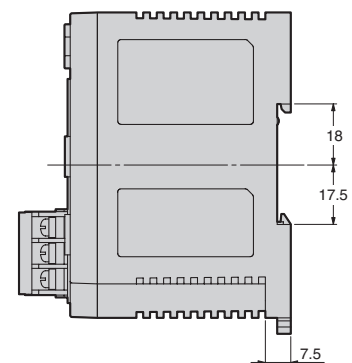
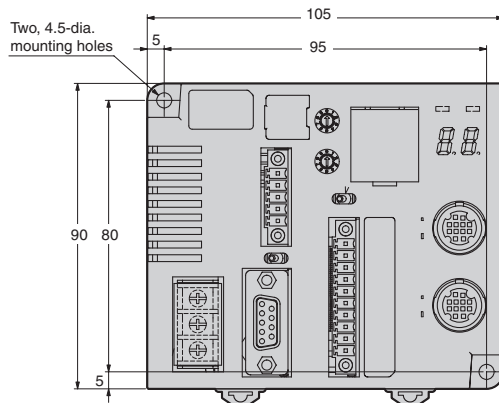
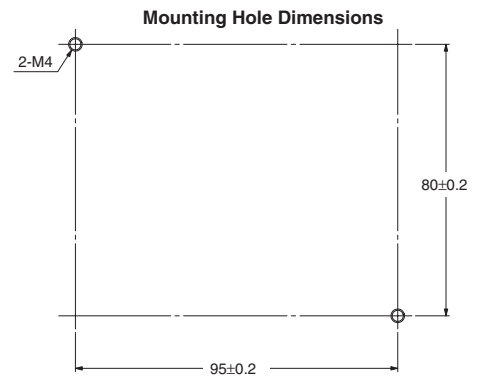
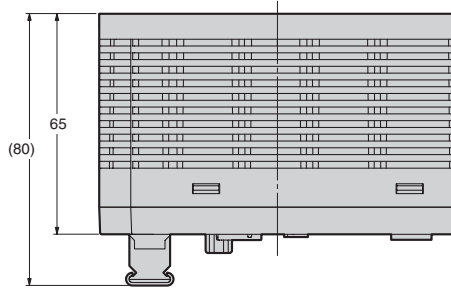

**Accessory**

**V680-D1KP66T Attachments**

**V600-A86 Holder**

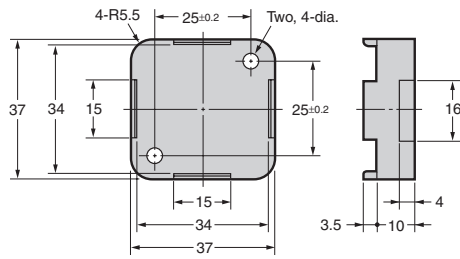
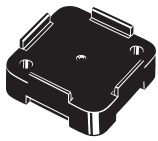

**Mounting Hole Dimensions**

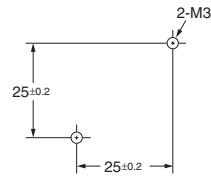

<b>Case material</b>	PPS resin
----------------------	-----------

**V680-D8KF68/-D32KF68 Attachments**

**V600-A81 Holder**

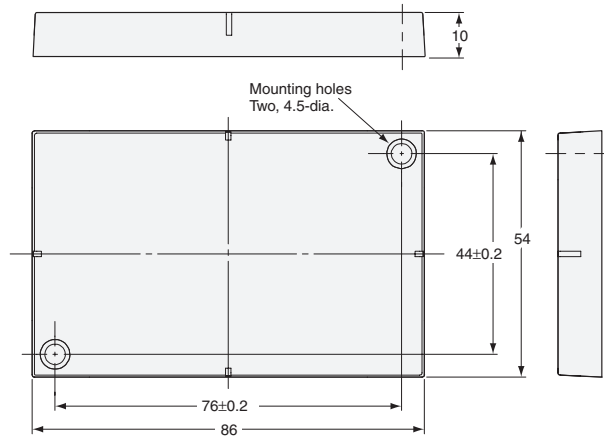

**Mounting Hole Dimensions**

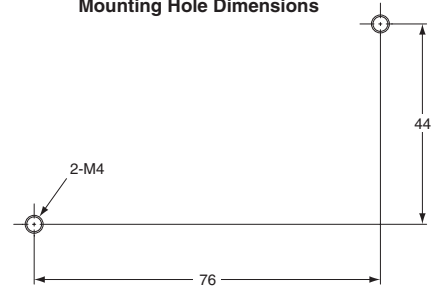

<b>Case material</b>	PBT resin
<b>Filling</b>	Epoxy resin

**V680-D1KP58HT Attachments**

**V680-A80**

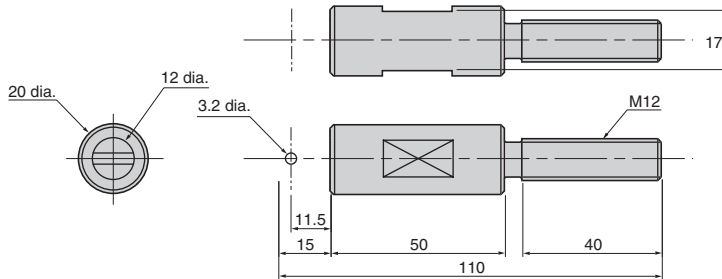

**Mounting Hole Dimensions**

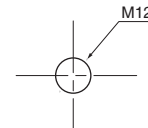

**V680-H01 Special Cables**

- V700-A40-W 2M
- V700-A40-W 5M
- V700-A40-W 10M
- V700-A40-W 20M
- V700-A40-W 30M

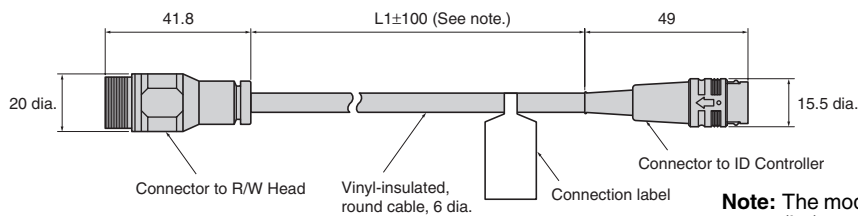

**Note:** The model numbers for each length (L1) are as follows:

Model	Length L1
V700-A40-W 2M	2,000
V700-A40-W 5M	5,000
V700-A40-W 10M	10,000
V700-A40-W 20M	20,000
V700-A40-W 30M	30,000

<b>Material</b>	PVC
-----------------	-----

## **READ AND UNDERSTAND THIS DOCUMENT**

Please read and understand this document before using the products. Please consult your OMRON representative if you have any questions or comments.

## **WARRANTY**

OMRON's exclusive warranty is that the products are free from defects in materials and workmanship for a period of one year (or other period if specified) from date of sale by OMRON.

OMRON MAKES NO WARRANTY OR REPRESENTATION, EXPRESS OR IMPLIED, REGARDING NON-INFRINGEMENT, MERCHANTABILITY, OR FITNESS FOR PARTICULAR PURPOSE OF THE PRODUCTS. ANY BUYER OR USER ACKNOWLEDGES THAT THE BUYER OR USER ALONE HAS DETERMINED THAT THE PRODUCTS WILL SUITABLY MEET THE REQUIREMENTS OF THEIR INTENDED USE. OMRON DISCLAIMS ALL OTHER WARRANTIES, EXPRESS OR IMPLIED.

## **LIMITATIONS OF LIABILITY**

OMRON SHALL NOT BE RESPONSIBLE FOR SPECIAL, INDIRECT, OR CONSEQUENTIAL DAMAGES, LOSS OF PROFITS OR COMMERCIAL LOSS IN ANY WAY CONNECTED WITH THE PRODUCTS, WHETHER SUCH CLAIM IS BASED ON CONTRACT, WARRANTY, NEGLIGENCE, OR STRICT LIABILITY.

In no event shall responsibility of OMRON for any act exceed the individual price of the product on which liability is asserted.

IN NO EVENT SHALL OMRON BE RESPONSIBLE FOR WARRANTY, REPAIR, OR OTHER CLAIMS REGARDING THE PRODUCTS UNLESS OMRON'S ANALYSIS CONFIRMS THAT THE PRODUCTS WERE PROPERLY HANDLED, STORED, INSTALLED, AND MAINTAINED AND NOT SUBJECT TO CONTAMINATION, ABUSE, MISUSE, OR INAPPROPRIATE MODIFICATION OR REPAIR.

## **SUITABILITY FOR USE**

THE PRODUCTS CONTAINED IN THIS DOCUMENT ARE NOT SAFETY RATED. THEY ARE NOT DESIGNED OR RATED FOR ENSURING SAFETY OF PERSONS, AND SHOULD NOT BE RELIED UPON AS A SAFETY COMPONENT OR PROTECTIVE DEVICE FOR SUCH PURPOSES. Please refer to separate catalogs for OMRON's safety rated products.

OMRON shall not be responsible for conformity with any standards, codes, or regulations that apply to the combination of products in the customer's application or use of the product.

At the customer's request, OMRON will provide applicable third party certification documents identifying ratings and limitations of use that apply to the products. This information by itself is not sufficient for a complete determination of the suitability of the products in combination with the end product, machine, system, or other application or use.

The following are some examples of applications for which particular attention must be given. This is not intended to be an exhaustive list of all possible uses of the products, nor is it intended to imply that the uses listed may be suitable for the products:

- Outdoor use, uses involving potential chemical contamination or electrical interference, or conditions or uses not described in this document.
- Nuclear energy control systems, combustion systems, railroad systems, aviation systems, medical equipment, amusement machines, vehicles, safety equipment, and installations subject to separate industry or government regulations.
- Systems, machines, and equipment that could present a risk to life or property.

Please know and observe all prohibitions of use applicable to the products.

NEVER USE THE PRODUCTS FOR AN APPLICATION INVOLVING SERIOUS RISK TO LIFE OR PROPERTY WITHOUT ENSURING THAT THE SYSTEM AS A WHOLE HAS BEEN DESIGNED TO ADDRESS THE RISKS, AND THAT THE OMRON PRODUCT IS PROPERLY RATED AND INSTALLED FOR THE INTENDED USE WITHIN THE OVERALL EQUIPMENT OR SYSTEM.

## **PERFORMANCE DATA**

Performance data given in this document is provided as a guide for the user in determining suitability and does not constitute a warranty. It may represent the result of OMRON's test conditions, and the users must correlate it to actual application requirements. Actual performance is subject to the OMRON Warranty and Limitations of Liability.

## **CHANGE IN SPECIFICATIONS**

Product specifications and accessories may be changed at any time based on improvements and other reasons.

It is our practice to change model numbers when published ratings or features are changed, or when significant construction changes are made. However, some specifications of the product may be changed without any notice. When in doubt, special model numbers may be assigned to fix or establish key specifications for your application on your request. Please consult with your OMRON representative at any time to confirm actual specifications of purchased products.

## **DIMENSIONS AND WEIGHTS**

Dimensions and weights are nominal and are not to be used for manufacturing purposes, even when tolerances are shown.

## **ERRORS AND OMISSIONS**

The information in this document has been carefully checked and is believed to be accurate; however, no responsibility is assumed for clerical, typographical, or proofreading errors, or omissions.

## **PROGRAMMABLE PRODUCTS**

OMRON shall not be responsible for the user's programming of a programmable product, or any consequence thereof.

## **COPYRIGHT AND COPY PERMISSION**

This document shall not be copied for sales or promotions without permission.

This document is protected by copyright and is intended solely for use in conjunction with the product. Please notify us before copying or reproducing this document in any manner, for any other purpose. If copying or transmitting this document to another, please copy or transmit it in its entirety.

**ALL DIMENSIONS SHOWN ARE IN MILLIMETERS.**

To convert millimeters into inches, multiply by 0.03937. To convert grams into ounces, multiply by 0.03527.

Cat. No. Q151-E1-03

**In the interest of product improvement, specifications are subject to change without notice.**

## **OMRON Corporation**

Industrial Automation Company

**Sensing Devices Division H.Q.**

**Industrial Sensors Division**

Shiokoji Horikawa, Shimogyo-ku,

Kyoto, 600-8530 Japan

Tel: (81)75-344-7022/Fax: (81)75-344-7107

*Regional Headquarters*

**OMRON EUROPE B.V.**

**Sensor Business Unit**

Carl-Benz-Str. 4, D-71154 Nufringen,

Germany

Tel: (49) 7032-811-0/Fax: (49) 7032-811-199

**OMRON ELECTRONICS LLC**

One Commerce Drive Schaumburg,

IL 60173-5302 U.S.A.

Tel: (1) 847-843-7900/Fax: (1) 847-843-7787

**OMRON ASIA PACIFIC PTE. LTD.**

No. 438A Alexandra Road # 05-05/08 (Lobby 2),

Alexandra Technopark, Singapore 119967

Tel: (65) 6835-3011/Fax: (65) 6835-2711

**OMRON (CHINA) CO., LTD.**

Room 2211, Bank of China Tower,

200 Yin Cheng Zhong Road,

Pu Dong New Area, Shanghai, 200120, China

Tel: (86) 21-5037-2222/Fax: (86) 21-5037-2200

Printed in Japan

0907-0.11M (1106) (M)

