

OV7960 NTSC/PAL product brief



Superior Image Quality for Professional Grade CCTV Cameras



available in
a lead-free
package

Optimized for NTSC and PAL applications, the OV7960 system on chip (SoC) with advanced image signal processing capabilities delivers vivid image capture even in the most challenging lighting conditions, making it an ideal solution for both indoor and outdoor security applications.

The low-voltage, high-performance OV7960 provides the full functionality of a single-chip analog NTSC/PAL sensor. Based on OmniVision's 6.0 μm OmniPixel3-HS™ architecture, the OV7960 features the industry's best-in-class low light sensitivity of 12 V/lux-sec. The OV7960 has an active array of 768 x 576 to support both PAL and NTSC formats without scaling.

The OV7960 incorporates advanced image processing functions, including exposure control, gain control,

white balance, lens correction and defective pixel correction to provide full-frame images. The functions are programmable through the serial camera control bus (SCCB) interface. For storage purposes, the OV7960 includes 16 bytes of one-time programmable (OTP) memory.

The OV7960 features automatic exposure/gain with 16 zone control, horizontal and vertical windowing capability, aperture/gamma correction, external frame sync capability and extremely low dark current for high temperature applications. The OV7960 comes in a CLCC package and is capable of operating within a temperature range of -20° to 70°C.

Find out more at www.ovt.com.

Applications

- Security and Surveillance

Product Features

- NTSC and PAL output
- high sensitivity
- automatic exposure/gain with 16 zone control
- horizontal and vertical windowing capability
- auto white balance control
- aperture/gamma correction
- external frame sync capability (Genlock)
- slave compatible serial camera control bus (SCCB) control interface for register programming
- low power consumption
- extremely low dark current for high temperature applications
- 50/60 Hz flicker cancellation
- SPI master for single static overlay and loading setting
- dynamic overlay controls
- defective pixel correction
- on screen display (OSD) support

OV7960

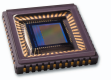

Ordering Information

- OV07960-C48N (color, NTSC, lead-free, 48-pin CLCC)
- OV07960-C48P (color, PAL, lead-free, 48-pin CLCC)

Product Specifications

- **active array size:**
 - NTSC: 656 x 492
 - PAL: 768 x 576
- **power supply:**
 - core: 1.5V
 - analog: 3.14 - 3.47V
 - I/O: 1.7 - 3.47V
- **power requirements:**
 - active: 225 mV
 - standby: 20 μ A
- **temperature range:**
 - operating: -20°C to 70°C junction temperature
 - stable image: 0°C to 50°C junction temperature
- **optical size:**
 - NTSC: 1/3.6"
 - PAL: 1/3"
- **lens chief ray angle:** 0° (no microlens shift)
- **output formats:** NTSC/PAL, CCIR656
- **maximum image transfer rate:**
 - NTSC: 60 fields per second
 - PAL: 50 fields per second
- **sensitivity:** 12 V/lux-sec
- **shutter:** rolling shutter
- **max S/N ratio:** 38 dB
- **dynamic range:** 70 dB @ 8x gain
- **scan mode:** interlaced
- **pixel size:** 6.0 μ m x 6.0 μ m
- **dark current:** 50 mV/s @ 60°C junction temperature
- **image area:** 4752 μ m x 3552 μ m
- **package dimensions:** 14.22 mm x 14.22 mm

Functional Block Diagram

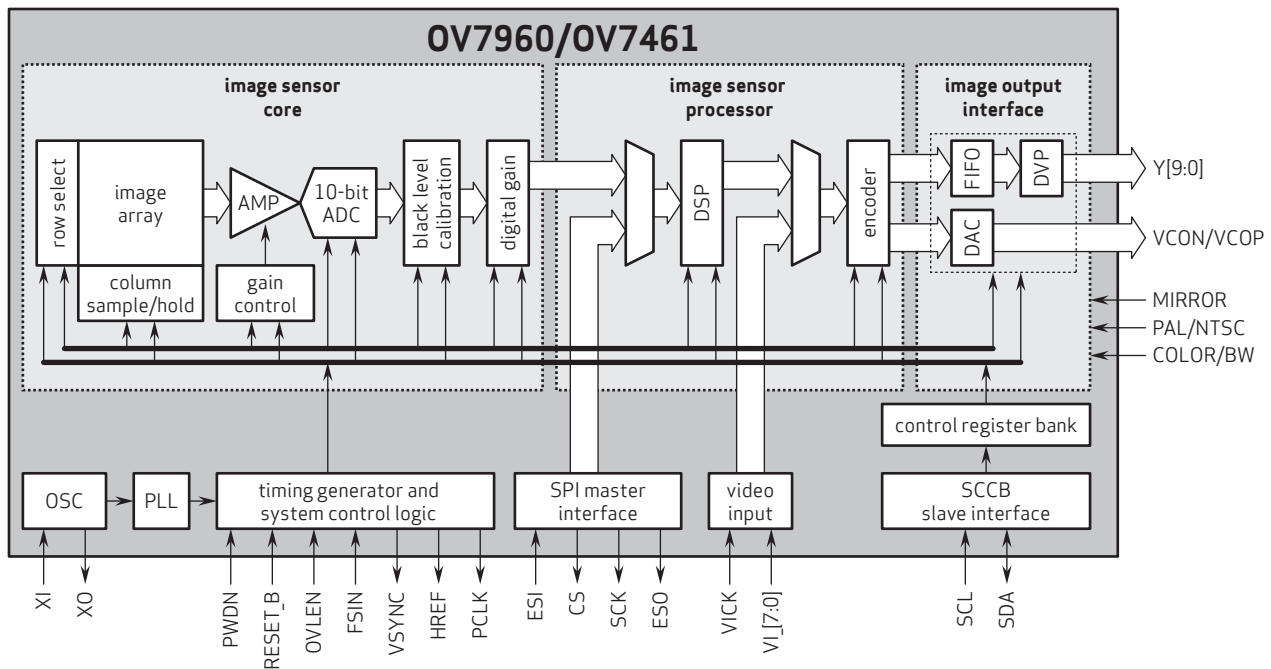

4275 Burton Drive
Santa Clara, CA 95054
USA

Tel: + 1 408 567 3000
Fax: + 1 408 567 3001
www.ovt.com

OmniVision reserves the right to make changes to their products or to discontinue any product or service without further notice. OmniVision, the OmniVision logo and OmniPixel are registered trademarks of OmniVision Technologies, Inc. OmniPixel3-HS is a trademark of OmniVision Technologies, Inc. All other trademarks are the property of their respective owners.

