

KADS-8070-2 SERIES

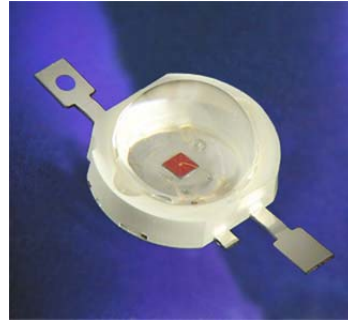

ATTENTION
OBSERVE PRECAUTIONS
FOR HANDLING
ELECTROSTATIC
DISCHARGE
SENSITIVE
DEVICES



Features

- Super high flux output and high luminance.
- Designed for high current operation.
- Low thermal resistance.
- Silicone resin with silicone lens.
- Compatible with IR-reflow processes.
- ESD protection .
- Package : 500pcs / reel.
- RoHS compliant.

Applications

- Substitution of micro incandescent lamps.
- Portable light source.
- Signal and symbol luminaire for orientation.
- Marker lights (e.g. steps, exit ways, etc).
- Decorative and entertainment lighting.
- Commercial and residential lighting.
- Emergency-vehicle lighting.

Application Note

Static electricity and surge damage the LEDs.

It is recommended to use a wrist band or anti-electrostatic glove when handling the LEDs.

All devices, equipment and machinery must be electrically grounded.

Package Dimensions

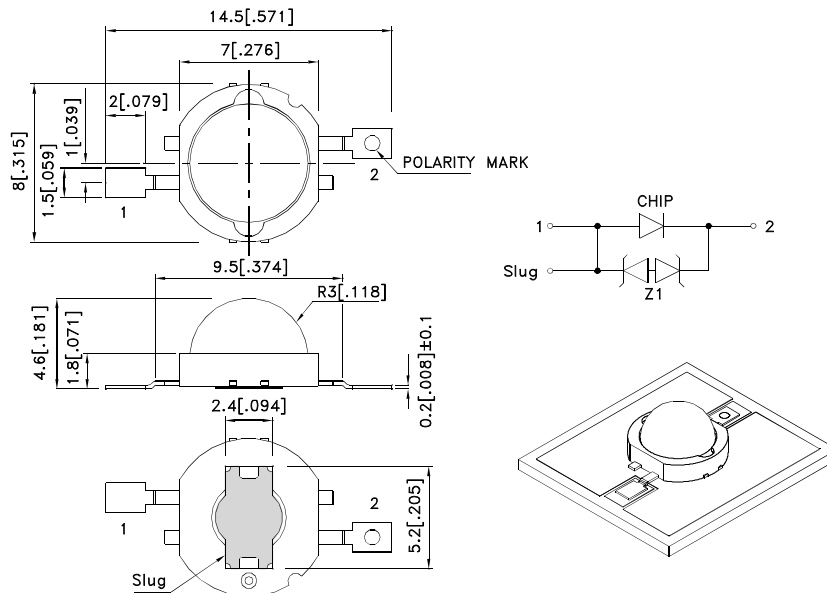

Notes:

1. All dimensions are in millimeters (inches).
2. Tolerance is $\pm 0.25(0.01)$ unless otherwise noted.
3. The specifications, characteristics and technical data described in the datasheet are subject to change without prior notice.
4. The device has a single mounting surface. The device must be mounted according to the specifications.



Flux Characteristics at 500mA Ambient Temperature, $T_a = 25^\circ\text{C}$

Color	Part No.	Luminous Flux (lm) @ 500mA [1]			Typical Luminous Flux (lm) [1]
		Code.	Min.	Max.	Typ.
Reddish-Orange (AlGaInP)	KADS-8070SE9Z1S/2	B7	29	35	43
		B8	35	42	
		B9	42	50	
		B10	50	60	
Super Bright Yellow (AlGaInP)	KADS-8070SY9Z1S/2	B6	24	29	37
		B7	29	35	
		B8	35	42	
		B9	42	50	

Note:

1. Minimum luminous flux performance guaranteed within published operating conditions. Kingbright maintains tolerance of +/-15% on flux.

Optical Characteristics at 500mA Ambient Temperature, $T_a = 25^\circ\text{C}$

Color	Dominant Wavelength [1] λ_D			Typical Spectral Halfwidth [2] (nm) $\Delta\lambda_{1/2}$	Typical Temperature Coefficient of Dominant Wavelength (nm/ $^\circ\text{C}$) $\Delta\lambda_D/\Delta T$	Typical Viewing Angle [3] (degrees) $2\theta_{1/2}$
	Min.	Typ.	Max.			
Reddish-Orange	619nm	623nm	629nm	22	0.03	90°
Super Bright Yellow	586nm	591nm	594nm	23	0.07	90°

Notes:

1. Dominant wavelength is derived from the CIE 1931 Chromaticity diagram and represents the perceived color.
2. Spectral width at 1/2 of the peak intensity.
3. Viewing angle is the off axis angle from lamp centerline where the luminous intensity is 1/2 of the peak value.

Electrical Characteristics at 500mA Ambient Temperature, $T_a = 25^\circ\text{C}$

Color	Forward Voltage V_f [1] (V)			Typical Temperature Coefficient of Forward Voltage [2] (mV/ $^\circ\text{C}$) $\Delta V_f/\Delta T$	Typical Thermal Resistance ($^\circ\text{C}/\text{W}$) $R_{th\ j\text{-slug}}$
	Min.	Typ.	Max.		
Reddish-Orange	2.0	2.7	3.3	-2.8	12
Super Bright Yellow	2.0	2.5	3.1	-2.6	12

Notes:

1. Kingbright maintains a tolerance of +/- 0.1V on forward voltage measurements.
2. Measured between $25^\circ\text{C} < T_J < 110^\circ\text{C}$ at $I_F = 500\text{ mA}$.

Absolute Maximum Ratings

Parameter	Reddish-Orange / Super Bright Yellow
DC Forward Current (mA) [1]	500
Peak Pulsed Forward Current (mA)	700
Average Forward Current (mA)	500
Reverse Voltage (V)	5
ESD Sensitivity	8000V HBM
LED Junction Temperature (°C)	110
Operation Temperature (°C)	-40 - 100
Storage Temperature (°C)	-40 - 110
Soldering Temperature (°C)	260 For 5 Seconds

Note:

1. Proper current derating must be observed to maintain junction temperature below the maximum.

Moisture Sensitivity

KADS-8070-2 LEDs are packaged in airtight and moisture-resistant bags to prevent moisture absorption which may lead to catastrophic failure in reflow soldering process. Kingbright recommends that the devices must be baked before soldering if they are removed from the original package, and are exposed to environmental conditions for longer than the durations (unit: days) defined in the table below. Recommended baking conditions are 24 hours at 80°C.

Temperature	Maximum Percent Relative Humidity						
	30%	40%	50%	60%	70%	80%	90%
30°C	9	5	4	3	1	1	1
25°C	12	7	5	4	2	1	1
20°C	17	9	7	6	2	2	1

Storage Conditions

After being removed from the original sealed package, KADS-8070-2 LEDs should be stored at a temperature of 25 °C with a relative humidity lower than 10%. Under such conditions, storage duration is excluded from the exposure duration as defined in the Moisture Sensitivity section.

Wavelength Characteristics $T_a = 25^\circ\text{C}$

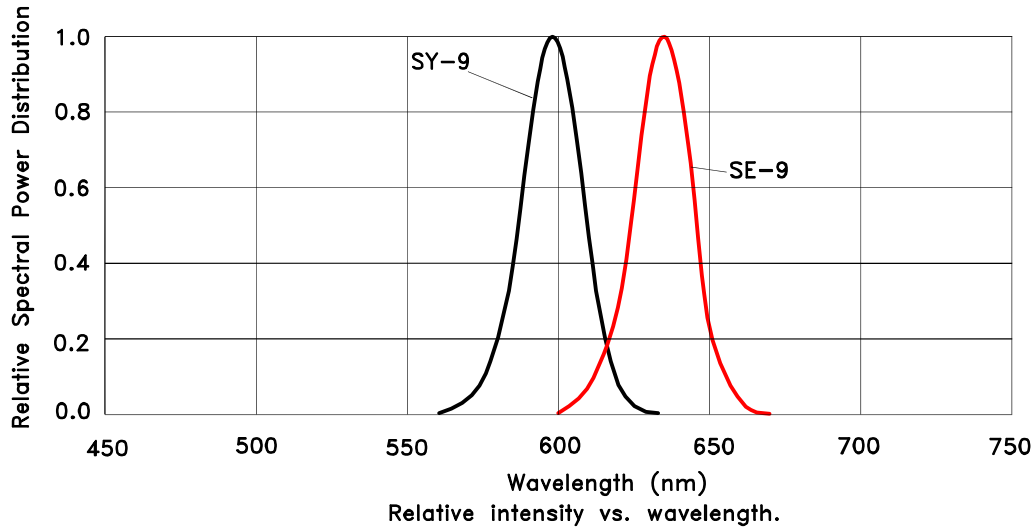

Light Output Characteristics

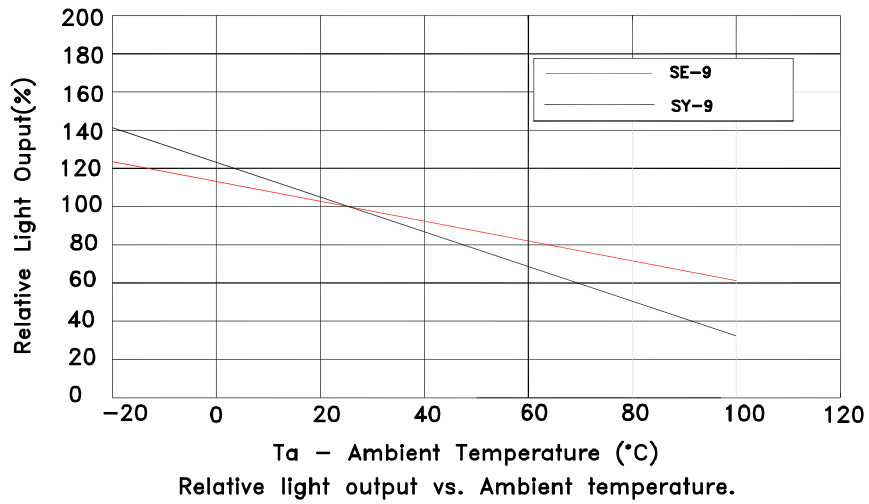

Forward Current Characteristics, $T_a = 25^\circ\text{C}$

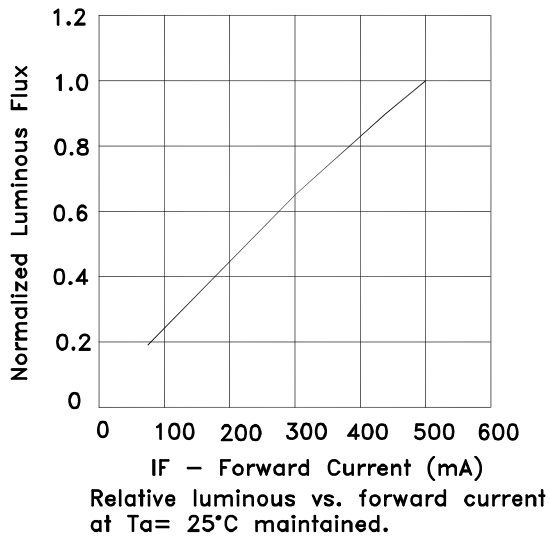
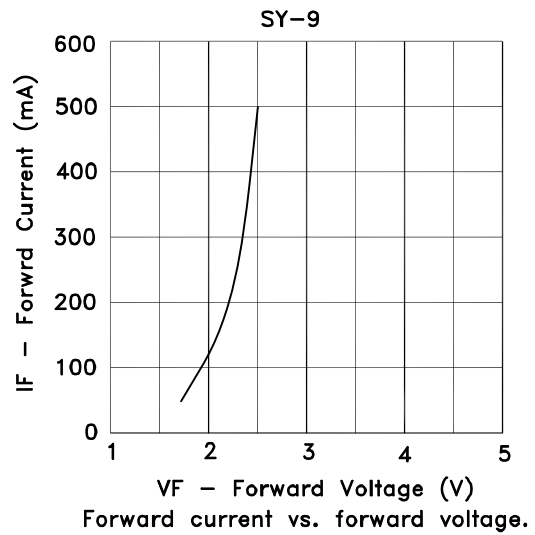
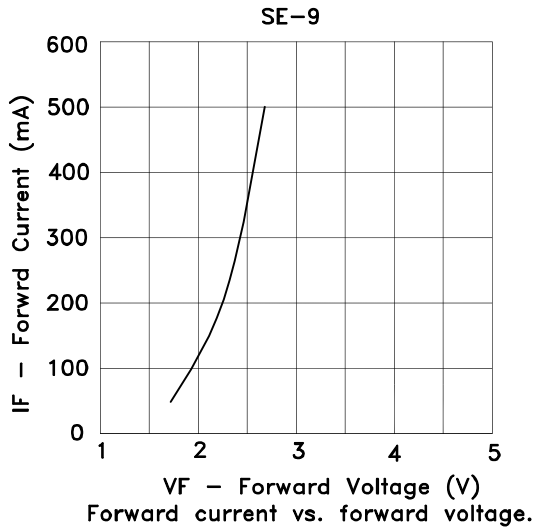

Current Derating Curves

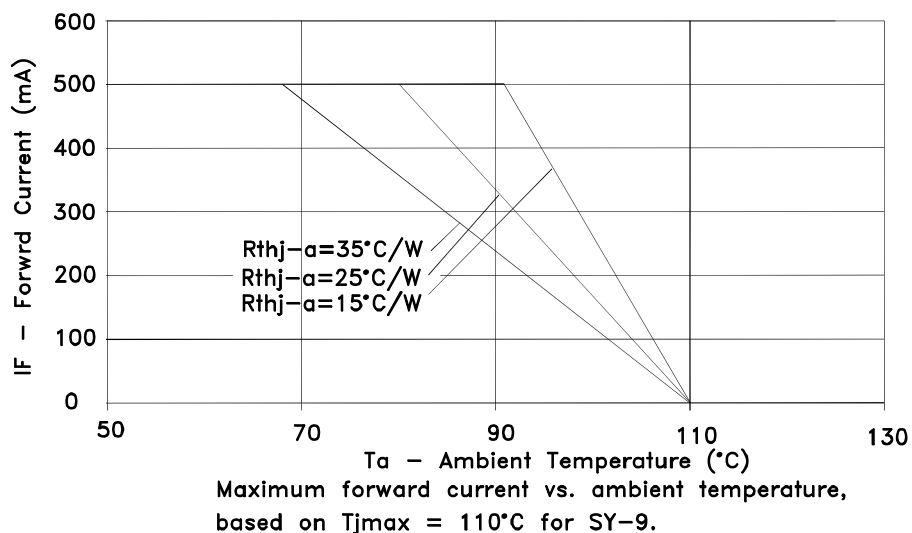
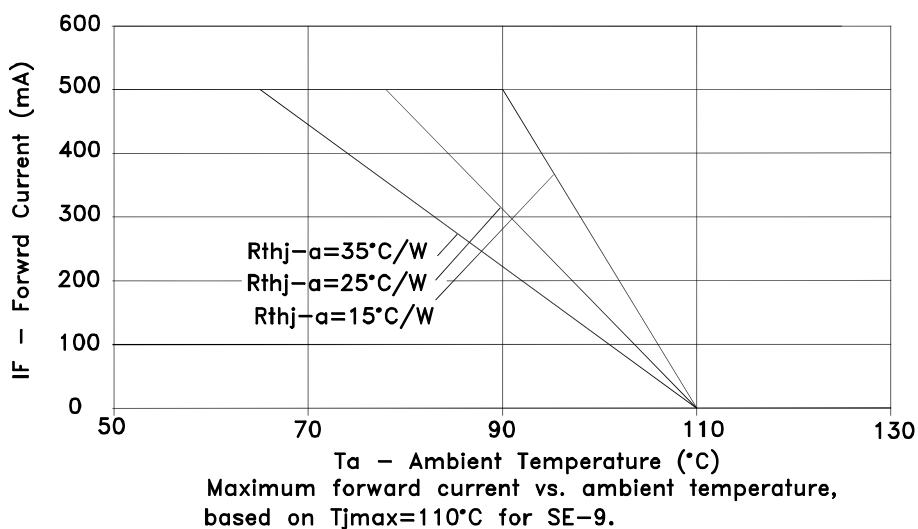

Representative Typical Spatial Radiation Pattern

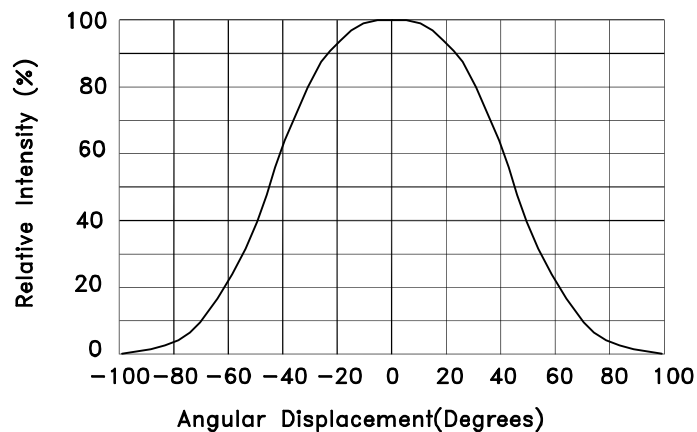

Reflow soldering is recommended and the soldering profile is shown below.
Other soldering methods are not recommended as they might cause damage to the product.

Reflow Soldering Profile For Lead-free SMT Process.

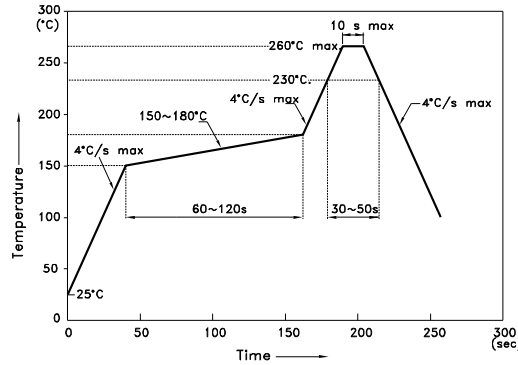

NOTES:

1. We recommend the reflow temperature 245°C (+/-5°C). The maximum soldering temperature should be limited to 260°C.
2. Don't cause stress to the epoxy resin while it is exposed to high temperature.
3. Number of reflow process shall be 2 times or less.

Heat Generation:

1. Thermal design of the end product is of paramount importance. Please consider the heat generation of the LED when making the system design. The coefficient of temperature increase per input electric power is affected by the thermal resistance of the circuit board and density of LED placement on the board, as well as other components. It is necessary to avoid intense heat generation and operate within the maximum ratings given in this specification.

2. Please determine the operating current with consideration of the ambient temperature local to the LED and refer to the plot of Permissible Forward current vs. Ambient temperature on CHARACTERISTICS in this specification. Please also take measures to remove heat from the area near the LED to improve the operational characteristics on the LED.

3. The equation ① indicates correlation between T_j and T_a , and the equation ② indicates correlation between T_j and T_s

$$T_j = T_a + R_{thj-a} * W \dots\dots\dots \textcircled{1}$$

$$T_j = T_s + R_{thj-s} * W \dots\dots\dots \textcircled{2}$$

T_j = dice junction temperature: °C

T_a = ambient temperature: °C

T_s = solder point temperature: °C

R_{thj-a} = heat resistance from dice junction temperature to ambient temperature : °C /W

R_{thj-s} = heat resistance from dice junction temperature to T_s measuring point : °C /W

W = inputting power (IFx VF) : W

Recommended Soldering Pattern (Units : mm ; Tolerance: ± 0.1)

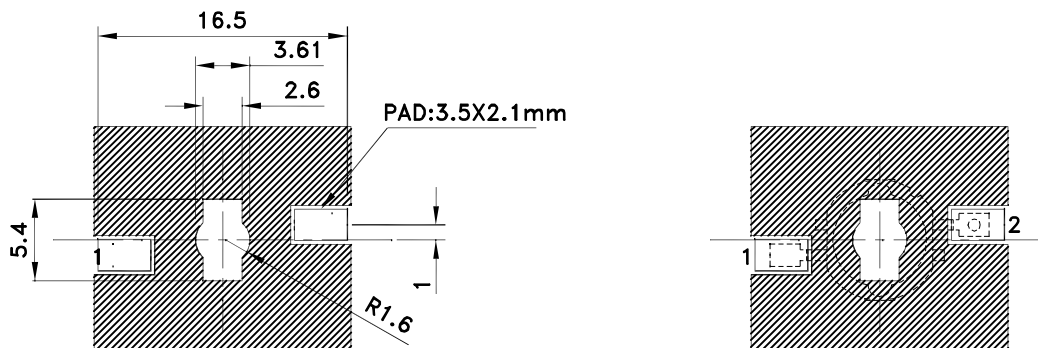

Tape Dimensions (Units : mm)

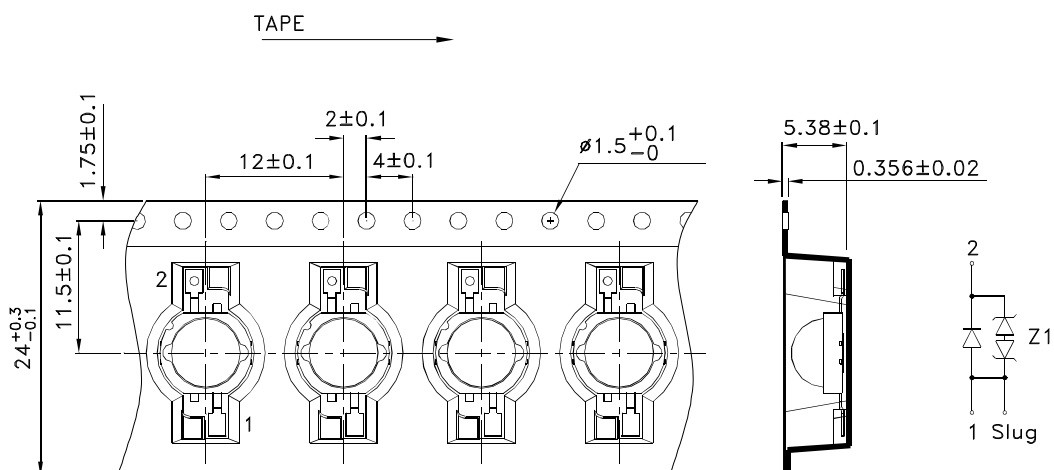

Reel Dimension

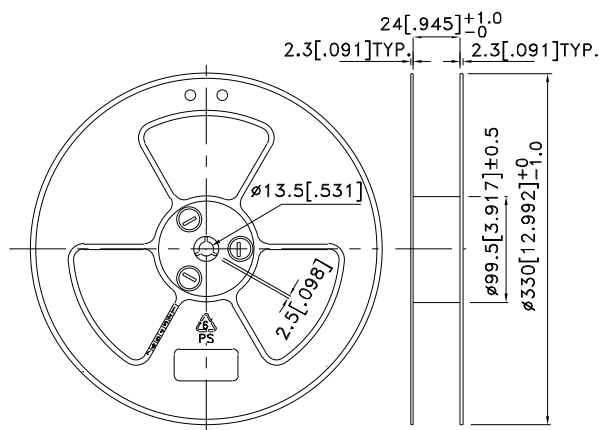

Kingbright

PACKING & LABEL SPECIFICATIONS

KADS-8070-2 SERIES

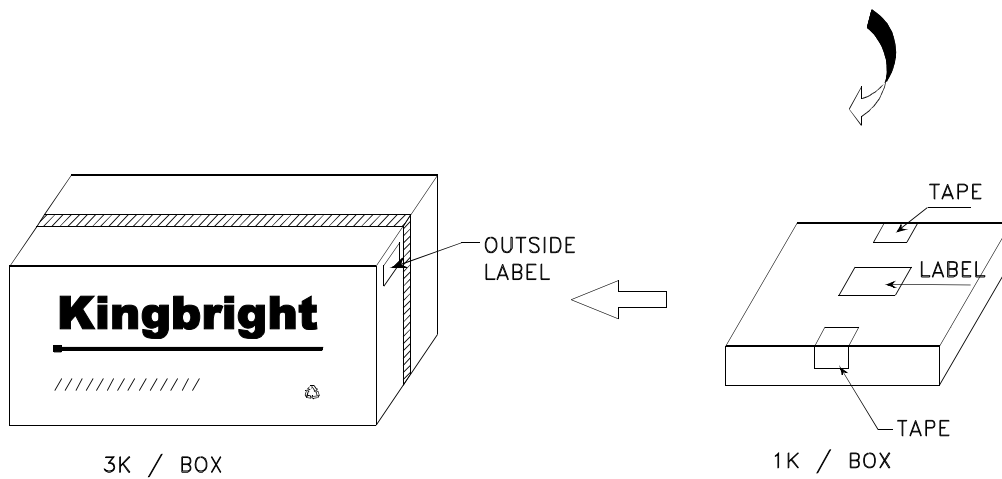
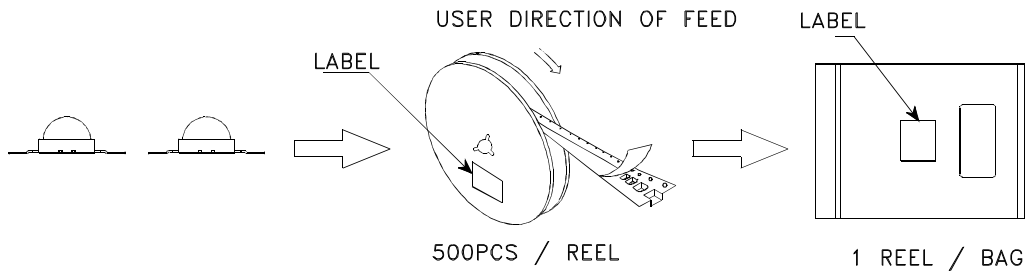

<h1>Kingbright</h1>	
P/NO: KADS-8070xxx	
QTY: 500 pcs	Q.C. Q C XX XX XXXX PASSED
S/N: XXXX	
CODE: XXX	
LOT NO:	
 XXXXXXXXXXXX	
RoHS Compliant	