



**Contactor relay, 2N/O+2N/C, DC current**

**Part no.** DILA-22(24VDC)  
**Article no.** 276414  
**Catalog No.** XTRE10B22TD



**Delivery programme**

Product range			DILA relays
Application			Contactor relays
Description			Basic devices with positive operation contacts
Connection technique			Screw terminals
<b>Rated operational current</b>			
AC-15			
220 V 230 V 240 V	$I_e$	A	4
380 V 400 V 415 V	$I_e$	A	4
<b>Contacts</b>			
N/O = Normally open			2 N/O
N/C = Normally closed			2 NC
Contact sequence			
<b>Code number and version of combination</b>			
Distinctive number			22E
Can be combined with auxiliary contact module			DILA-XHI(V)...
Actuating voltage			24 V DC
Voltage AC/DC			DC operation
Suppressor circuit			built-in
<b>Instructions</b>			Contact numbers to EN 50011 Coil terminal markings to EN 50005 built-in suppressor circuit'

**Technical data**

<b>General</b>			
Standards			IEC/EN 60947, VDE 0660, UL, CSA
Lifespan, mechanical			
AC operated	Operations	$\times 10^6$	20
DC operated	Operations	$\times 10^6$	20
Maximum operating frequency			
Maximum operating frequency	Operations/h		9000
Climatic proofing			
Damp heat, constant, to IEC 60068-2-78 Damp heat, cyclic, to IEC 60068-2-30			
Ambient temperature			
Open		°C	-25 - +60
Enclosed		°C	- 25 - 40
Ambient temperature, storage		°C	- 40 - 80
Mounting position			
Mounting position			
Mechanical shock resistance (IEC/EN 60068-2-27)			
Half-sinusoidal shock, 10 ms			
Basic unit with auxiliary contact module		g	

N/O contact	g	7
N/C contact	g	5
Degree of Protection		IP20
Protection against direct contact when actuated from front (EN 50274)		Finger and back-of-hand proof
Weight		
AC operated	kg	0.23
DC operated	kg	0.28
Terminal capacities	mm <sup>2</sup>	
Screw terminals		
Solid	mm <sup>2</sup>	1 x (0,75 - 4) 2 x (0,75 - 2,5)
Flexible with ferrule	mm <sup>2</sup>	1 x (0,75 - 2,5) 2 x (0,75 - 2,5)
Solid or stranded	AWG	18 - 14
Terminal screw		M3.5
Pozidriv screwdriver	Size	2
Standard screwdriver	mm	0.8 x 5.5 1 x 6
Max. tightening torque	Nm	1.2
Spring-loaded terminals		
Solid	mm <sup>2</sup>	1 x (0,75 - 2,5) 2 x (0,75 - 2,5)
Flexible with or without ferrule DIN 46228	mm <sup>2</sup>	1 x (0,75 - 1,5) 2 x (0,75 - 1,5)
Solid or stranded	AWG	18 - 14
Standard screwdriver	mm	0.6 x 3.5

## Contacts

Positive operating contacts to ZH 1/457, including auxiliary contact module			Yes
Rated impulse withstand voltage	$U_{imp}$	V AC	6000
Overvoltage category/pollution degree			III/3
Rated insulation voltage	$U_i$	V AC	690
Rated operational voltage	$U_e$	V AC	690
Rated operational current		A	
Conventional free air thermal current, 3 pole, 50 - 60 Hz			
Open			
Conv. thermal current	$I_{th}$	A	16
AC-15			
220 V 230 V 240 V	$I_e$	A	4
380 V 400 V 415 V	$I_e$	A	4
500 V	$I_e$	A	1.5
DC current			
DC-13 L/R - 15 ms			
Contacts in series:		A	
1	24 V	A	10
1	60 V	A	6
2	60 V	A	10
1	110 V	A	3
3	110 V	A	6
1	220 V	A	1
3	220 V	A	5
DC L/R  50 ms			
Contacts in series:		A	
3	24 V	A	4
3	60 V	A	4
3	110 V	A	2
3	220 V	A	1

Conv. thermal current	$I_{th}$	A	16
Safe isolation to EN 61140			
between coil and auxiliary contacts		V AC	400
between the auxiliary contacts		V AC	400
Control circuit reliability	Failure rate	$\lambda$	$<10^{-8}$ , < one failure at 100 million operations (at $U_e = 24$ V DC, $U_{min} = 17$ V, $I_{min} = 5.4$ mA)
Short-circuit rating without welding			
Maximum overcurrent protective device			
220 V 230 V 240 V		PKZM0	4
380 V 400 V 415 V		PKZM0	4
Short-circuit protection maximum fuse			
500 V		A gG/gL	10
Current heat loss at $I_{th}$			
AC operated		W	0.3
DC operated		W	0.3

## Magnet systems

Voltage tolerance		$\times U_c$	
AC operated		$\times U_c$	
	Pick-up	$\times U_c$	0.8 - 1.1
DC operated		$\times U_c$	
	Pick-up	$\times U_c$	0.8 - 1.1
at 24 V: without auxiliary contact component (40 °C)	Pick-up	$\times U_c$	0.7 - 1.3
Power consumption			
50 Hz	Pick-up	VA	24
50 Hz	Sealing	VA	3.4
50 Hz	Sealing	W	1.2
60 Hz	Pick-up	VA	30
60 Hz	Sealing	VA	4.4
60 Hz	Sealing	W	1.4
50/60 Hz	Pick-up	VA	27 25
50/60 Hz	Sealing	VA	4.2 3.3
50/60 Hz	Sealing	W	1.4 1.2
DC operated	Pull-in = sealing	W	3
duty factor		% DF	100
Switching times at 100 % $U_c$ (approximate values)			
AC operated closing delay		ms	15 - 21
AC operated N/O contact opening delay		ms	9 - 18
DC operated closing delay		ms	
Switching times, DC operated, max. closing delay		ms	31
DC operated N/O contact opening delay		ms	
Switching times, DC actuated make contact Opening delay, max.		ms	12

## Notes

**Notes** Making and breaking conditions to DC-13, time constant as stated  
Smoothed DC, three-phase bridge rectifiers or smoothed double-wave rectification

## Design verification as per IEC/EN 61439

Technical data for design verification			
Rated operational current for specified heat dissipation	$I_n$	A	15.5
Heat dissipation per pole, current-dependent	$P_{vid}$	W	1
Equipment heat dissipation, current-dependent	$P_{vid}$	W	0
Static heat dissipation, non-current-dependent	$P_{vs}$	W	2.6
Heat dissipation capacity	$P_{diss}$	W	0
Operating ambient temperature min.		°C	-25

Operating ambient temperature max.	°C	60
IEC/EN 61439 design verification		
10.2 Strength of materials and parts		
10.2.2 Corrosion resistance		Meets the product standard's requirements.
10.2.3.1 Verification of thermal stability of enclosures		Meets the product standard's requirements.
10.2.3.2 Verification of resistance of insulating materials to normal heat		Meets the product standard's requirements.
10.2.3.3 Verification of resistance of insulating materials to abnormal heat and fire due to internal electric effects		Meets the product standard's requirements.
10.2.4 Resistance to ultra-violet (UV) radiation		Meets the product standard's requirements.
10.2.5 Lifting		Does not apply, since the entire switchgear needs to be evaluated.
10.2.6 Mechanical impact		Does not apply, since the entire switchgear needs to be evaluated.
10.2.7 Inscriptions		Meets the product standard's requirements.
10.3 Degree of protection of ASSEMBLIES		Does not apply, since the entire switchgear needs to be evaluated.
10.4 Clearances and creepage distances		Meets the product standard's requirements.
10.5 Protection against electric shock		Does not apply, since the entire switchgear needs to be evaluated.
10.6 Incorporation of switching devices and components		Does not apply, since the entire switchgear needs to be evaluated.
10.7 Internal electrical circuits and connections		Is the panel builder's responsibility.
10.8 Connections for external conductors		Is the panel builder's responsibility.
10.9 Insulation properties		
10.9.2 Power-frequency electric strength		Is the panel builder's responsibility.
10.9.3 Impulse withstand voltage		Is the panel builder's responsibility.
10.9.4 Testing of enclosures made of insulating material		Is the panel builder's responsibility.
10.10 Temperature rise		The panel builder is responsible for the temperature rise calculation. Eaton will provide heat dissipation data for the devices.
10.11 Short-circuit rating		Is the panel builder's responsibility. The specifications for the switchgear must be observed.
10.12 Electromagnetic compatibility		Is the panel builder's responsibility. The specifications for the switchgear must be observed.
10.13 Mechanical function		The device meets the requirements, provided the information in the instruction leaflet (IL) is observed.

## Technical data ETIM 6.0

Low-voltage industrial components (EG000017) / Contactor relay (EC000196)		
Electric engineering, automation, process control engineering / Low-voltage switch technology / Contactor (LV) / Contactor relay (ec @ss8.1-27-37-10-01 [AAB716011])		
Rated control supply voltage $U_s$ at AC 50HZ	V	0 - 0
Rated control supply voltage $U_s$ at AC 60HZ	V	0 - 0
Rated control supply voltage $U_s$ at DC	V	24 - 24
Voltage type for actuating		DC
Rated operation current $I_e$ , 400 V	A	4
Connection type auxiliary circuit		Screw connection
Mounting method		DIN-rail/screw
Interface		No
Number of auxiliary contacts as normally closed contact		2
Number of auxiliary contacts as normally open contact		2
Number of auxiliary contacts as normally closed contact, delayed switching		0
Number of auxiliary contacts as normally open contact, leading		0
With LED indication		No
Number of auxiliary contacts as change-over contact		0
Manual operation possible		No

## Approvals

Product Standards		IEC/EN 60947-4-1; UL 508; CSA-C22.2 No. 14-05; CE marking
UL File No.		E29184
UL Category Control No.		NKCR
CSA File No.		012528
CSA Class No.		3211-03
North America Certification		UL listed, CSA certified

## Characteristics

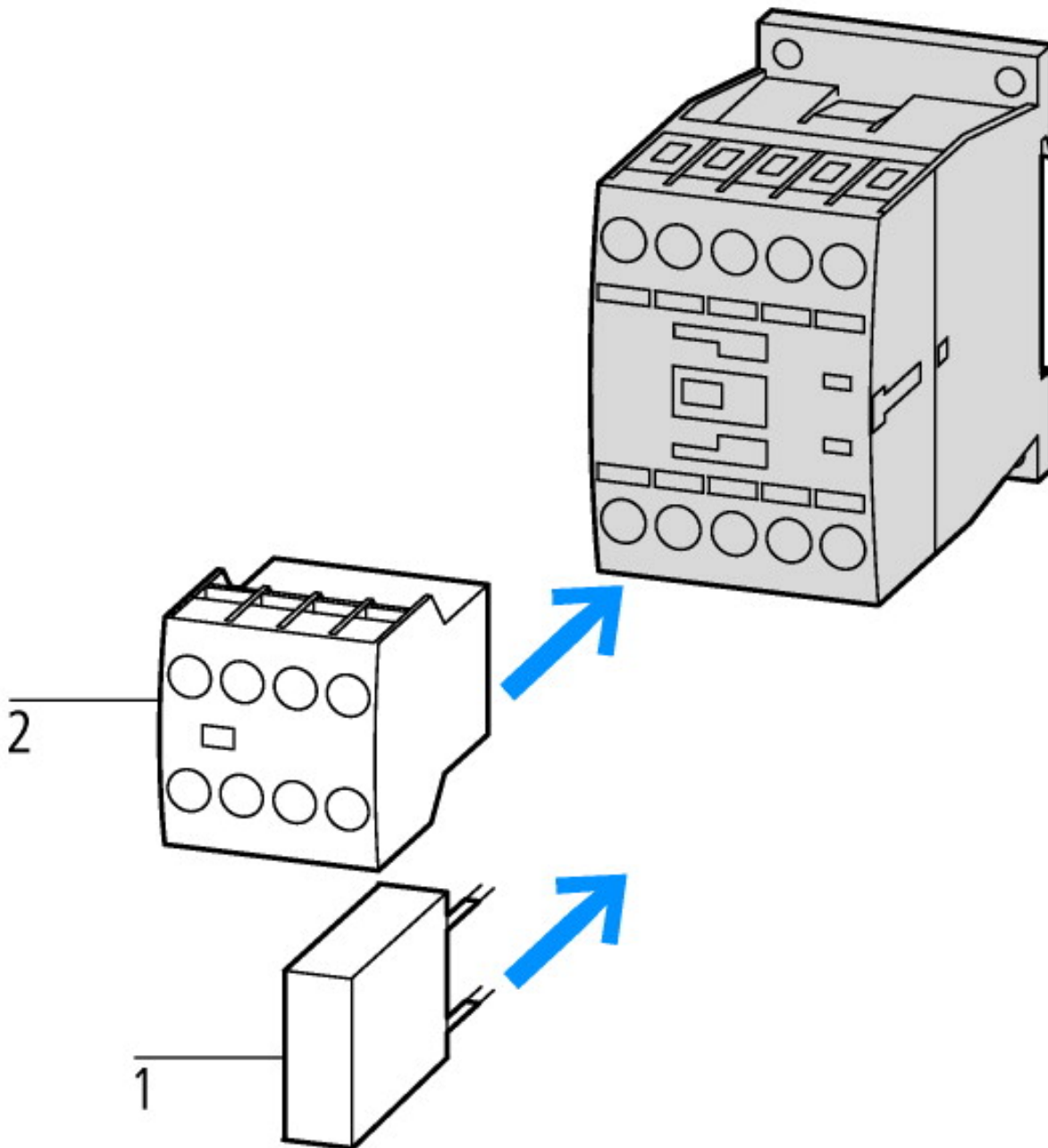

- 1: Suppressor
- 2: Auxiliary contact module

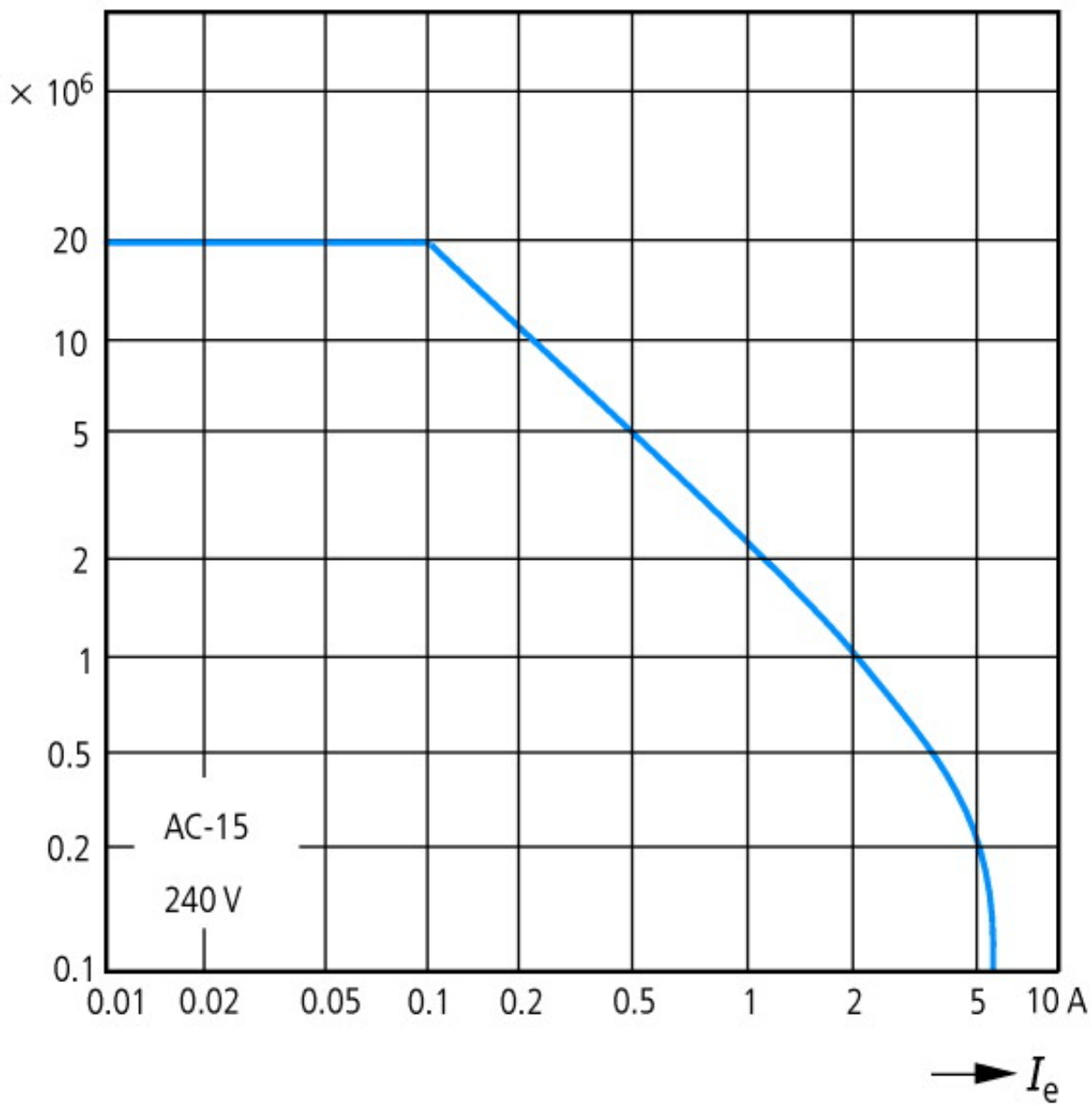

Component lifespan (operations)  
 $I_e$  = Rated operational current

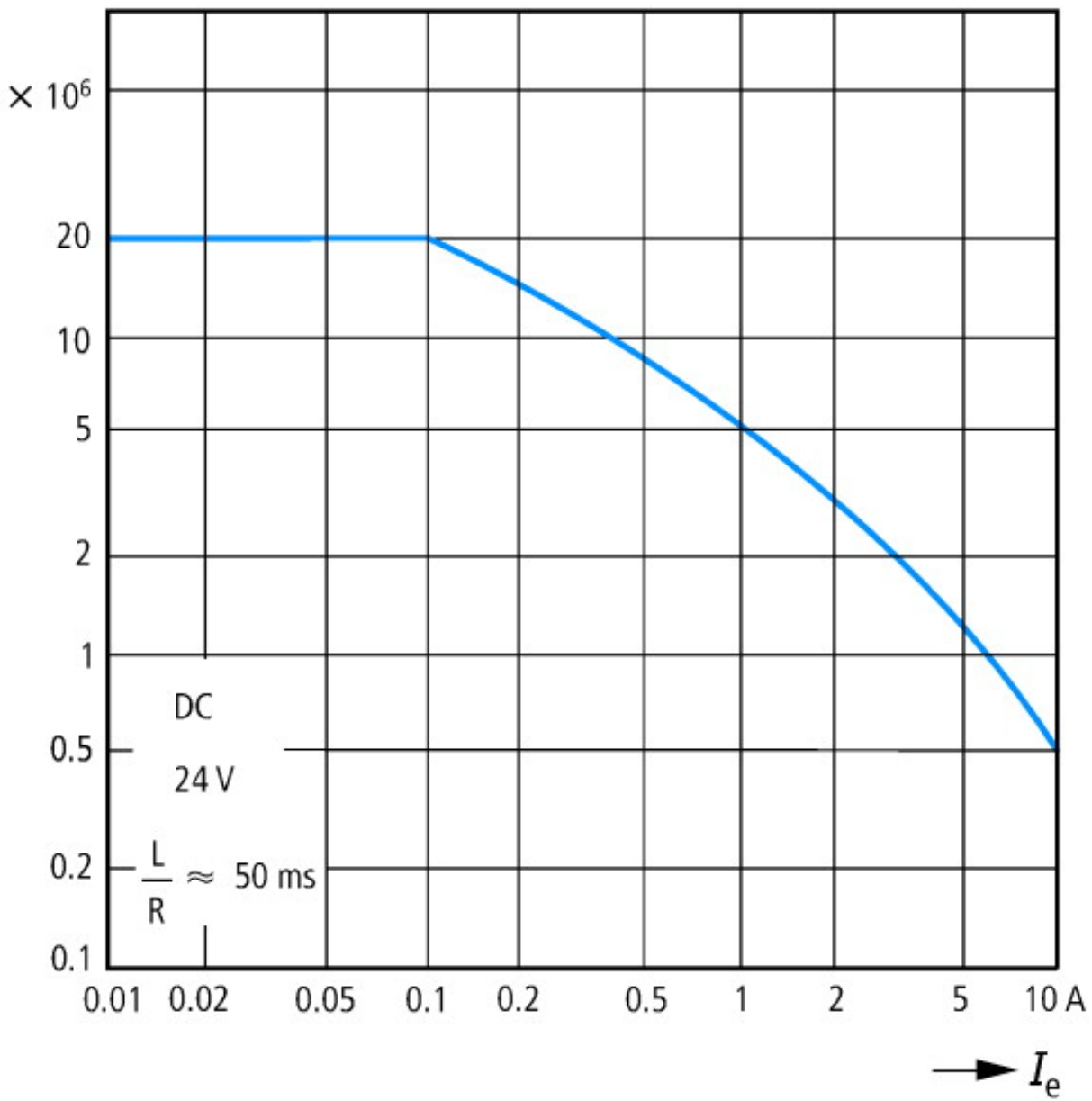

Component lifespan (operations)  
 $I_e$  = Rated operational current

## Dimensions

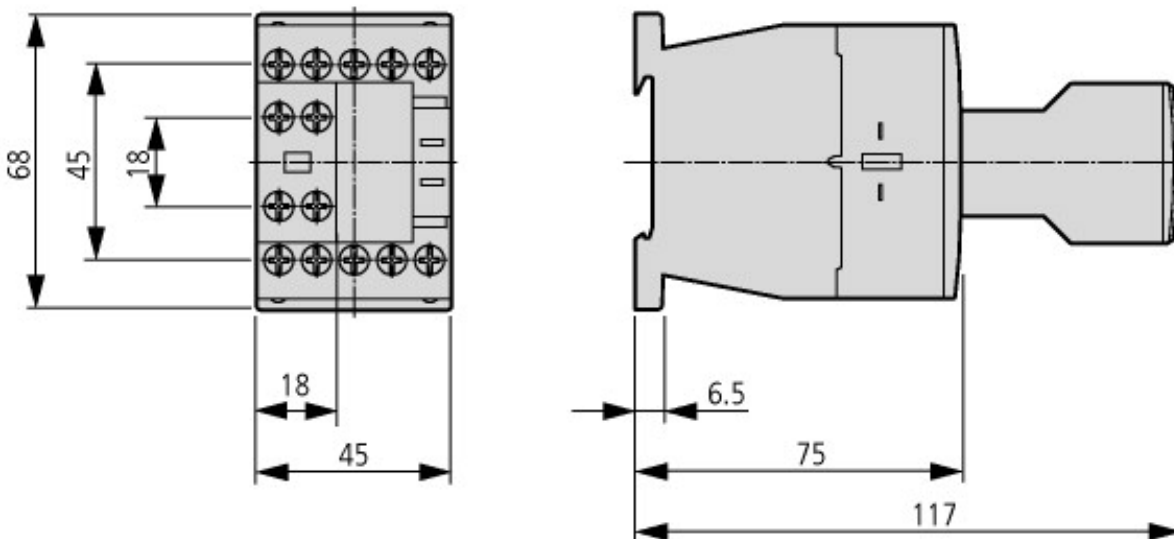

Contactor with auxiliary contact module

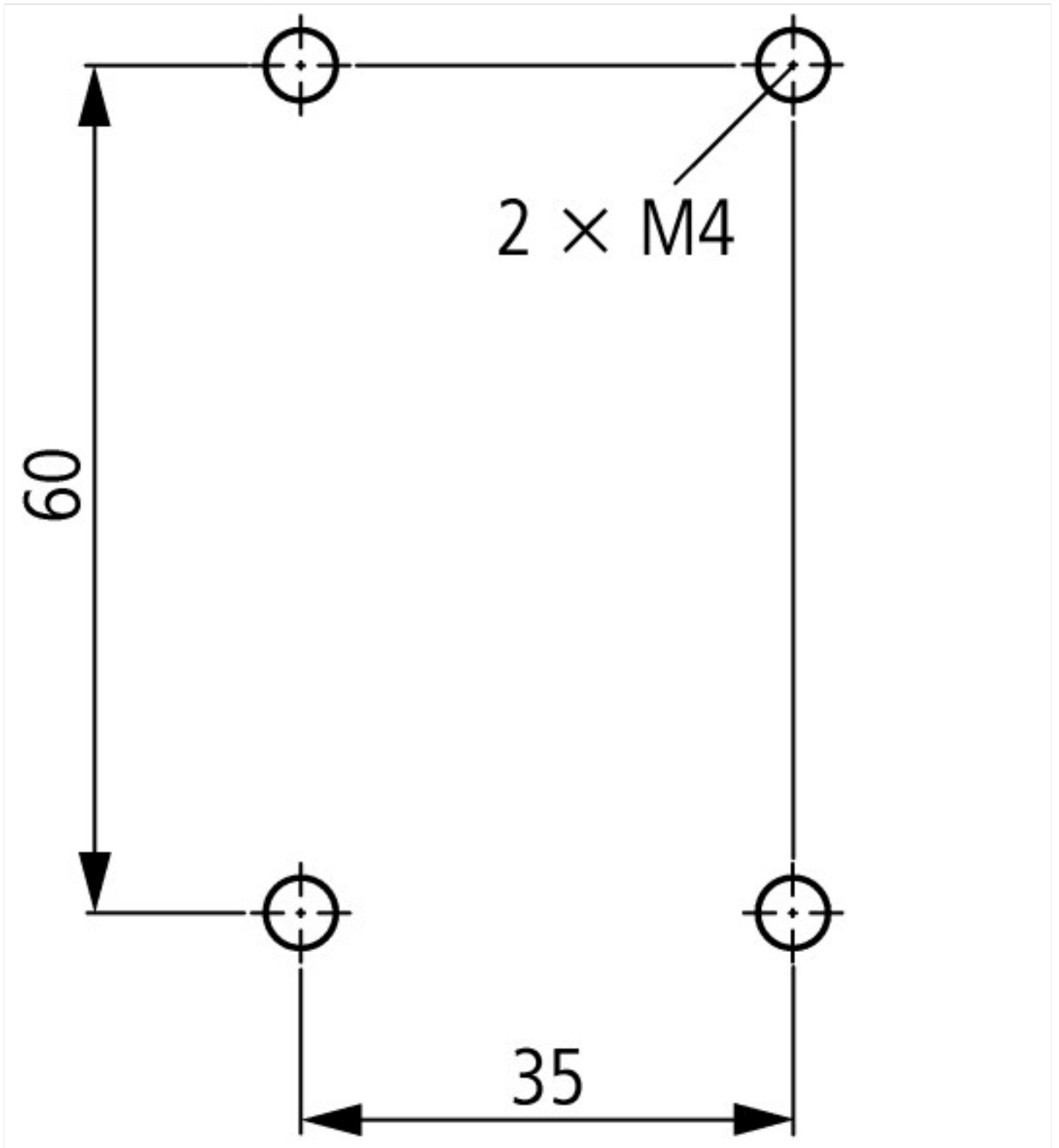

### Additional product information (links)

#### IL03407013Z (AWA2100-2126) Contactors

IL03407013Z (AWA2100-2126) Contactors [ftp://ftp.moeller.net/DOCUMENTATION/AWA\\_INSTRUCTIONS/IL03407013Z2012\\_03.pdf](ftp://ftp.moeller.net/DOCUMENTATION/AWA_INSTRUCTIONS/IL03407013Z2012_03.pdf)

UL/CSA: Approved rating data <http://de.ecat.moeller.net/flip-cat/?edition=HPLTE&startpage=5.84>