

# UTS series IP68 / IP69K Plastic Connectors

Part of the TRIM TRIO® interconnect system

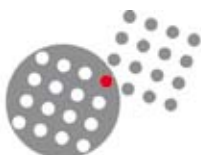

**SOURIAU**  
Connection Technology



# Company Profile

## SOURIAU

### Connectors and interconnect systems for severe environments

The company designs, manufactures and markets high performance interconnect solutions for severe environments from industrial broadband and universal ranges to complex system with integrated functions: filtering, high speed data transmission, hermetic seal, separation mechanism, remote handling, underwater mating, ...



Industrial



Aeronautical



Equipment & System

The dedicated end markets for SOURIAU's products are aeronautical, defense-space and industrial



Railway  
Geophysics  
Manufacturing environment  
Instrumentation  
Automation & process



Civil & military aircraft  
Helicopter  
Weapon delivery system  
Avionics



Military marine  
Communications  
Satellites  
Launcher & missile

SOURIAU was established in 1977 and has been created by successive acquisitions of the industrial, aeronautical, defense and space activities of SOURIAU, JUPITER and BURNDY.

The Group's products are engineered and manufactured in the USA and Dominican Republic, Europe and Morocco, Japan and India, and sold by a worldwide sales and marketing organization, and in addition to SOURIAU's offices, a large network of licensed distributors and agents.

SOURIAU complies with most of national and international Quality Assurance Standards, production unit with ISO 14001

Quality Certificate  
Management System

ISO 9001

Environment Certificate  
Management System

ISO 14001

Quality Certificate  
Management System

Aeronautic Industry : EN 9100



# Content



<b>Company Profile</b> .....	<b>2</b>
<b>Contents</b> .....	<b>3</b>
<b>Overview</b> .....	<b>4-7</b>
<b>UTS range: Benefits</b> .....	<b>8-10</b>
<b>Connectors (contacts non included)</b> .....	<b>11-33</b>
• UTS connectors .....	11-18
• UTS discrete wire sealing .....	19-24
<b>Contacts</b> .....	<b>25-54</b>
• RC/RM machined contacts #16 .....	25-30
• SC/SM machined contacts #16 .....	31-34
• Multipiece coaxial contacts .....	35-38
• Monocrimp coaxial contacts .....	39-42
• Fibre optic contacts .....	43-46
• Machined / Stamped & Formed contacts #20 .....	47-50
• Power contacts .....	51-54
<b>Pre-equipped connectors</b> .....	<b>55-70</b>
• UTS Hi seal .....	55-62
• UTS with screw termination contacts .....	63-66
• UTS RJ45 .....	67-70
<b>Accessories</b> .....	<b>71-72</b>
<b>Tooling</b> .....	<b>73-78</b>
<b>What is IP rating?</b> .....	<b>79</b>
<b>What is NEMA?</b> .....	<b>80</b>
<b>Applications</b> .....	<b>81</b>



# Overview

Description	
<p><b>IP68 / IP69K plastic circular connector with rapid locking system</b></p> <p>UTS is the latest addition to the well known TRIM TRIO® interconnect system. UTS is a range of industrial circular multiway connectors.</p> <p>The keywords for the new UTS are: <b>Rapid - Secure - High performance</b></p>	
<p><b>• Rapid</b></p> 	<p>Rapid refers to the locking system and the total installed cost starting with the wiring &amp; cabling and ending with the installation to the customers equipment. Rapid also refers to the total service on price request, samples and production deliveries.</p>
<p><b>• Secure</b></p> 	<p>The secure locking system together with the secure and versatile TRIM TRIO® contacts are giving confidence to both the connection and the customer's equipment. Moreover UTS is part of the well-known TRIM TRIO® interconnect system with its more than 40 years of field experience.</p>
<p><b>• High Performance</b></p> 	<p>Extreme performance on water protection even in dynamic situations this in combination with a rapid and secure locking system makes UTS suitable for any high performance application.</p>

**UTS**  
page 11-18



**UTS discrete wire sealing**  
page 19-24



**UTS Hi seal**  
page 55-62



**UTS screw termination contacts** - page 63-66



**UTS RJ45**  
page 67-70



UTS provides a connection that performs faster, easier, safer and more reliable, it makes :

**UTS : Your first choice in waterproof connectors !**



# Overview

**UTS, part of the TRIM TRIO® interconnect system**  
Any TRIM TRIO® contact can be used in any combination in any connector style

## Contacts\*



Machined



Stamped & formed



Coax



Fibre Optic



UTP  
Simplicity



UTS Sealed  
Plastic\*\*



UTG  
Intensive Use



UTO Full Metal  
& Shielding



MBG Ultra  
Intensive Use

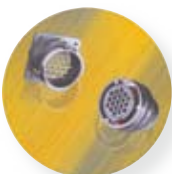

UTV Highly  
Ruggedized



MSM/MSO  
High Density



V.35  
High Density  
DTE/DCE

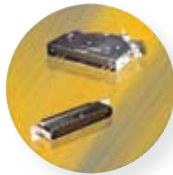

MSG/MB  
High Density  
Low Profile



SMS  
Quick Mating

\* Only valid for contact #16 / \*\*Except pre-equipped connectors

**UTS : Your first choice in waterproof connectors !**



# Overview

## UTS contact arrangements

Size 8						
2	3	3A/98	4	33		
Contacts : 2 Ø 1 (#20)	Contacts : 3 Ø 1 (#20)	Contacts : 3 Ø 1 (#20)	Contacts : 4 Ø 1 (#20)	Contacts : 3 Ø 1 (#20)		

Size 10						
2W2	3	3W3	4	6	7	98
Contacts : 2 Ø2.4 (#12) 2 Ø1.0 (#20)	Contacts* : 3 Ø 1.6 (#16)	Contacts : 3 Ø 1.6 (#16) 3 Ø 1.0 (#20)	Contacts : 4 Ø 1.6 (#16)	Contacts : 6 Ø 1 (#20)	Contacts : 7 Ø 1 (#20)	Contacts : 6 Ø 1 (#20)

Size 12						
2	3	4	8	8	10	14
Contacts : 2 Ø 1.6 (#16)	Contacts : 3 Ø 1.6 (#16)	Contacts* : 4 Ø 1.6 (#16)	Contacts : 8 Ø 1.6 (#16)	Contacts : 8 Ø 1 (#20)	Contacts : 10 Ø 1 (#20)	Contacts : 14 Ø 1 (#20)

Size 14						
5	7	12	12	15	18	19
Contacts : 5 Ø 1.6 (#16)	Contacts* : 7 Ø 1.6 (#16)	Contacts : 12 Ø 1.6 (#16)	Contacts : 8 Ø 1 (#20) 4 Ø 1.6 (#16)	Contacts : 14 Ø 1 (#20) 1 Ø 1.6 (#16)	Contacts : 18 Ø 1 (#20)	Contacts : 19 Ø 1 (#20)

\* Arrangements with advanced grounding cavity (For other arrangements, First Mate, Last Break contacts are available - see from page 27)

**UTS : Your first choice in waterproof connectors !**



# Overview

**Size 18**

<b>11</b>	<b>23</b>	<b>32</b>	<b>30</b>	<b>RJ45</b>
Contacts : 11 Ø 1.6 (#16)	Contacts : 23 Ø 1.6 (#16)	Contacts : 32 Ø 1 (#20)	Contacts : 29 Ø 1 (#20) 1 Ø 1.6 (#16)	

- UTS standard version
- UTS Hi seal version
- ▲ UTS discrete wire sealing version
- UTS with screw contact termination
- In-Line version

For specific arrangements, please consult us



## Working voltage according to VDE & UL standards

			VDE0110	UL1977
			Overvoltage class III, pollution degree 2 / IEC 60664-1 (equivalent)	Type 2
<div style="margin-bottom: 10px;"> <b>#16</b> Ø 1.6 mm         </div> <div style="margin-bottom: 10px;"> <b>#20</b> Ø 1.0 mm         </div> <div> <b>Mixed<sup>1</sup></b> </div>	Shell size	Nb of contacts	320 V*	500 V**
	10	3	400 V*	
	12	4	125 V	500 V**
	14	7	125 V	250 V**
	18	23 <sup>1</sup>	200 V	500 V
	18	32 <sup>1</sup>	50 V	250 V

<sup>1</sup> Not certified

Note : all the written working voltage are in Volts AC/DC

\* tested by the VDE organism

\*\* certified by the UL organism (only for shell size 10, 12 & 14)

**UTS : Your first choice in waterproof connectors !**



# UTS series

## Major features & benefits



### Rapid & secure locking system

- ➡ Confidence that the connector is properly mated
- ➡ Easy to connect in difficult places
- ➡ Minimalised operator fatigue
- ➡ Labor saving



### Rapid and secure panel mounting

Rear panel mount solution suitable for pre-harnessing and PCB mounting

Captive panel seal

Robust jam nut to guarantee a rapid, secure and vibration proof panel mounting

D-shape panel cut to ensure correct mounting and to prevent the connector from rotating

O-ring seal to guarantee sealing between receptacle and plug

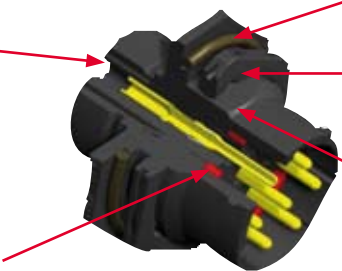

#### Assembly procedure of jam nut receptacle

Step 1

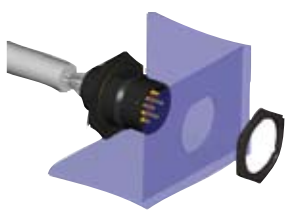

Step 2

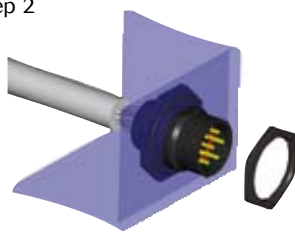

Step 3

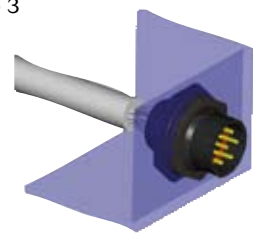

#### Assembly procedure of square flange receptacle

Step 1

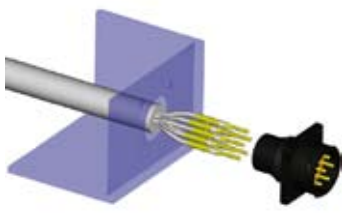

Step 2

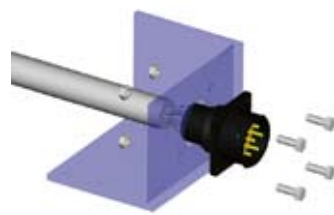

Step 3

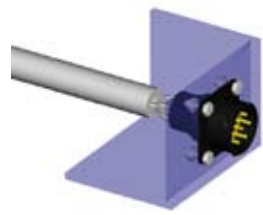

**UTS : Your first choice in waterproof connectors !**



# UTS series



## Ergonomic plug design with maximized cabling space and minimized connector length



«Easy grip» bayonet coupling ring to allow quick and secure mating

O-ring seal to guarantee sealing between plug and backshell

Colored rings available for visual identification (see accessories page 72)



## Backshells ... accepting a wide range of cables



Wide cable range

Size 8	1.5 to 6.5 mm
Size 10	1.5 to 8.0 mm
Size 12	3.0 to 12.0 mm
Size 14	5.0 to 14.0 mm
Size 18	7.0 to 18.0 mm

Low installed cost with reduced number of components



## Sealing caps ... easy to install ... at any time

➡ Receptacle sealing cap

➡ Plug sealing cap

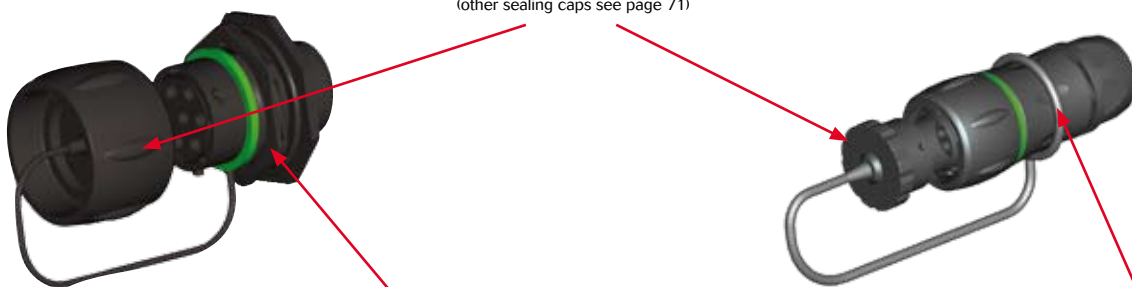

Sealing cap  
(other sealing caps see page 71)

- easy attachment to connector at any time

- easy attachment to connector at any time

### UTS : Your first choice in waterproof connectors !

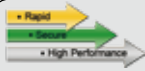

## Extreme environmental sealing performance

➡ IP68 / IP69K sealing ... even in dynamic situations

➡ Dynamic IP68

Connector will remain IP68 even when:

- Pulling on the cable
- Bending the cable

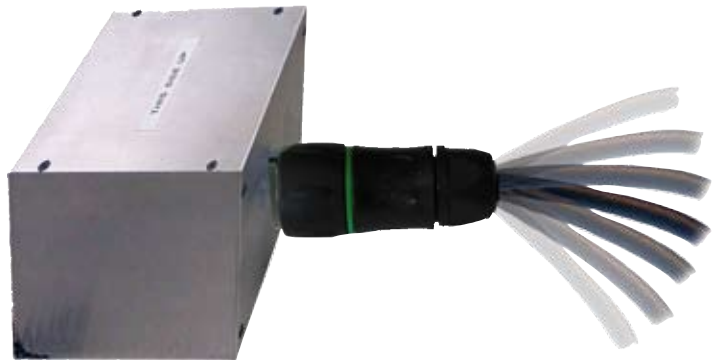

➡ Dynamic IP69K

Connector withstands high pressure water cleaning

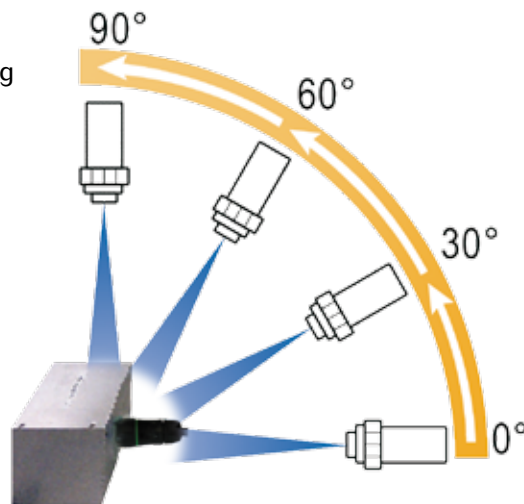

**UTS : Your first choice in waterproof connectors !**

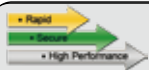

## Description

### IP68/IP69K - Plastic connector

- UTS series is a range of industrial plastic circular connectors offering **IP68/IP69K water protection**.  
4 shell sizes - up to 32 contact positions - are available with different contact styles in size 16 & size 20:
  - Machined contacts
  - Stamped & formed contacts
  - Coax contacts
  - Fibre optic contacts
- Other typical UTS features are:
  - Rapid & secure locking system
  - Extreme environmental sealing performances
  - Easy visual identification
  - Rapid wiring, cabling & installation
  - Suitable for a wide range of industrial applications

**UTS : Your first choice in waterproof connectors !**



## Technical characteristics

### Mechanical

- Durability: 250 matings & unmatings
- Vibration resistance: Sinusoidal vibrations per CEI 60512-4 - from 10 to 2000 Hz  
5 cycles 30 min. from -40°C to 105°C
- Thermal shock: per MIL-STD 1344 method 1003

### Electrical

- Current per contact max.:  
Size 16: 13A  
Size 20: 7.5A - machined contact  
5A - stamped & formed contact
- Insulation resistance: ≥ 5000 MΩ
- Test potential: 2000 VAC - #16 contact  
1500 VAC - #20 contact
- Working voltage: up to 400 V class III, PD 2 as per VDE  
up to 500 V as per UL1977  
see page 7 for more details

### Environmental

- Operating temperature: -40°C to + 105°C
- Flammability rating: UL94-V0
- Salt spray: 500 hours
- Sealing (mated):  
Dynamic IP68 - 10 m under water for 1 week per IEC60529  
Dynamic IP69K per DIN40050
- UV resistant:  
No mechanical degradation or important variation of color after 5 years of exposure in natural environment (equivalence exposure to sun and moisture as per ISO4892)

### Material

- Connectors + Backshell: Thermoplastic

### Contact accommodation

- UTS connectors accept TRIM TRIO® size 16 or size 20 (depending on arrangement) removable snap-lock contacts
- Contacts to be ordered separately (except PCB versions) - see from page 25 to 54

In accordance with UL requirements (UL ECBT2.E169916 and CSA ECBT8.E169916)

## Ordering information

Type	UTS	6	JC	12	10	S
	UTS	7	-	12	10	P
	UTS	1	JC	12	10	S
<b>Connector type</b>						
0 Square flange receptacle						
6 Cable plug						
7 Jam nut receptacle						
1 In-line receptacle						
<b>Rear of the connector</b>						
JC Backshell (only for plug & In-line version)						
<b>Shell size</b> 10 - 12 - 14 - 18						
<b>Number of contacts</b> - see next page						
<b>Contact Gender</b>						
P: Pin contacts / S: Socket contacts						





UTS : Your first choice in waterproof connectors !





# UTS

## UTS contact arrangements



**Size 10**

<b>2W2</b> 	<b>3</b> 	<b>3W3</b> 	<b>4</b> ♦ 	<b>6</b> 
Contacts : 2 Ø2.4 (#12) 2 Ø1.0 (#20)	Contacts* : 3 Ø 1.6 (#16)	Contacts : 3 Ø 1.6 (#16) 3 Ø 1.0 (#20)	Contacts : 4 Ø 1.6 (#16)	Contacts : 6 Ø 1 (#20)

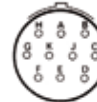

**Size 12**

<b>4</b> 	<b>8</b> ♦ 	<b>10</b> 
Contacts* : 4 Ø 1.6 (#16)	Contacts : 8 Ø 1.6 (#16)	Contacts : 10 Ø 1 (#20)

**Size 14**

<b>7</b> 	<b>12</b> ♦ 	<b>19</b> 
Contacts* : 7 Ø 1.6 (#16)	Contacts : 12 Ø 1.6 (#16)	Contacts : 19 Ø 1 (#20)

**Size 18\*\***

<b>23</b> ♦ 	<b>32</b> 
Contacts : 23 Ø 1.6 (#16)	Contacts : 32 Ø 1 (#20)

\* Arrangements with advanced grounding cavity  
 \*\* For in-line version shell size 18, please consult us

All arrangements are available in plug and jam nut versions.  
 Arrangements marked with ♦ are available in square flange version as well.

**UTS : Your first choice in waterproof connectors !**



## Cable plug with backshell for pin & socket contacts

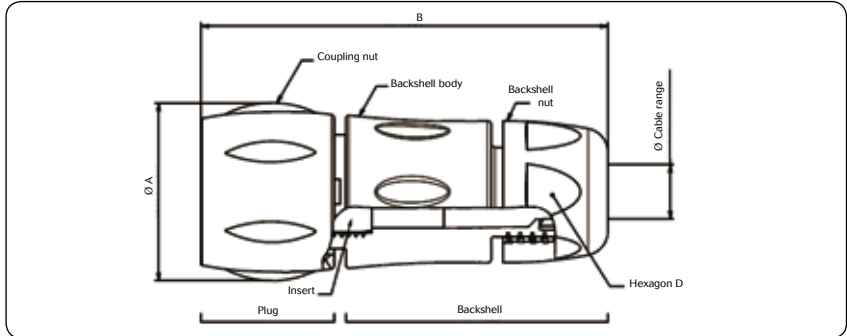

Shell size	Part numbers		Ø A	B	Ø Cable range Standard seal	Ø Cable range Reducing seal	Hexagon D
	Male contact	Female contact					
10	UTS6JC10 - - - P	UTS6JC10 - - - S	26.7	63.2	2.5 / 8.0	1.5 / 5.0	18.5
12	UTS6JC12 - - P	UTS6JC12 - - S	30.15	66.7	5.0 / 12.0	3.0 / 9.0	24.0
14	UTS6JC14 - - P	UTS6JC14 - - S	35.1	71.5	7.0 / 14.0	5.0 / 12.0	26.0
18	UTS6JC18 - - P	UTS6JC18 - - S	42.0	81.3	9.0 / 18.0	7.0 / 16.0	33.0

Coloured ring supplied as optional extra (see page 72).

Each plug has 2 seals to cover the specified cable range (see table).

The standard seal is preassembled. The second seal is supplied as loose piece together with a plug.



## Jam nut receptacle for pin & socket contacts

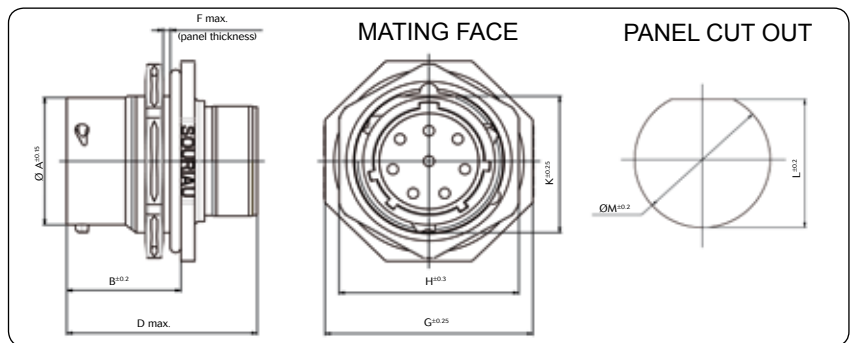

Shell size	Part numbers		Ø A	B	D max	F max	G	H	L	Ø M	Tightening torque
	Male contact	Female contact									
10	UTS710 - - - P	UTS710 - - - S	14.9	19.3	33.9	3.2	27.0	22.2	16.5	17.7	3
12	UTS712 - - P	UTS712 - - S	19.0	19.3	33.9	3.2	31.8	27.0	21.2	22.5	4
14	UTS714 - - P	UTS714 - - S	22.2	19.3	33.9	3.2	34.9	30.2	24.3	25.7	5
18	UTS718 - - P	UTS718 - - S	28.5	19.3	33.9	3.2	41.3	36.6	30.6	32.0	5

Coloured ring supplied as optional extra (see page 72).

Note : all dimensions are in mm

**UTS : Your first choice in waterproof connectors !**



## In-line receptacle for pin & socket contacts

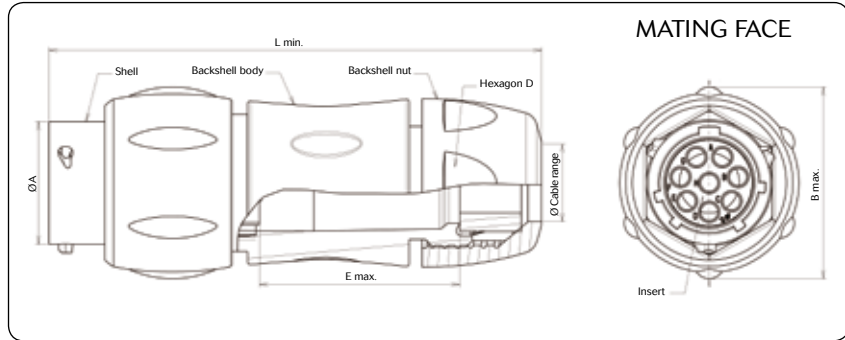

Shell size	Part numbers		Ø A	L min.	B max	Ø Cable range Standard seal	Ø Cable range Reducing seal	Hexagon D	E max	
	Male contact	Female contact							Male	Female
10	UTS1JC10 --- P	UTS1JC10 --- S	14.9	70.0	26.7	2.5/8.0	1.5/5.0	18.5	31.0	38.0
12	UTS1JC12 --- P	UTS1JC12 --- S	19.0	74.0	30.1	5.0/12.0	3.0/9.0	24.0	34.0	41.5
14	UTS1JC14 --- P	UTS1JC14 --- S	22.2	78.5	35.1	7.0/14.0	5.0/12.0	26.0	38.0	45.5
18*	UTS1JC18 --- P	UTS1JC18 --- S	28.5	89.0	42.0	9.0/18.0	7.0/16.0	33.0	46.5	54.0

For shell size 18, please consult us  
Coloured ring supplied as optional extra (see page 72).



## Square flange receptacle

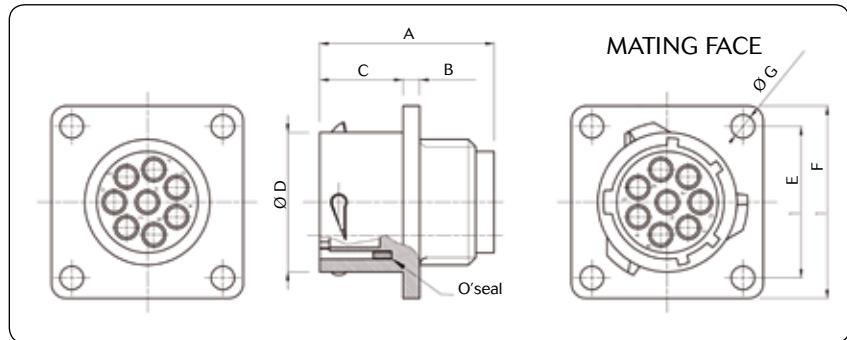

Shell size	Part numbers		A max.	B <sup>±0.15</sup>	C <sup>±0.2</sup>	Ø D <sup>±0.15</sup>	E <sup>±0.25</sup>	F <sup>±0.25</sup>	Ø G <sup>±0.1</sup>	Ø H <sup>±0.1</sup>	Ø J <sup>±0.1</sup>
	Male contact	Female contact									
10	UTS0104P	UTS0104S	24.3	2.3	11.3	15.0	18.3	23.8	3.2	17.3	15.1
12	UTS0128P	UTS0128S	24.3	2.3	11.3	19.0	20.6	26.2	3.2	21.8	18.2
14	UTS01412P	UTS01412S	24.3	2.3	11.3	22.2	23.0	28.6	3.2	25.0	21.4
18	UTS01823P	UTS01823S	24.3	2.5	11.3	28.5	26.9	33.3	3.2	31.3	27.8

Coloured ring supplied as optional extra (see page 72).

Note : all dimensions are in mm

**UTS : Your first choice in waterproof connectors !**



## PCB jam nut receptacle for male contacts



MALE CONNECTOR

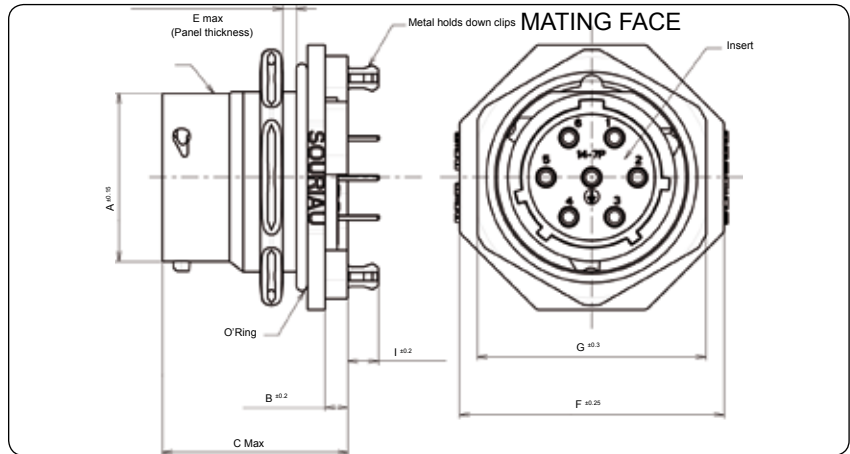

DRILLING PATTERNS

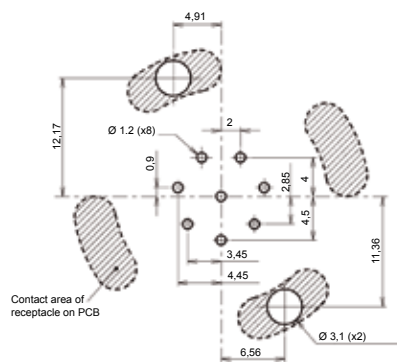
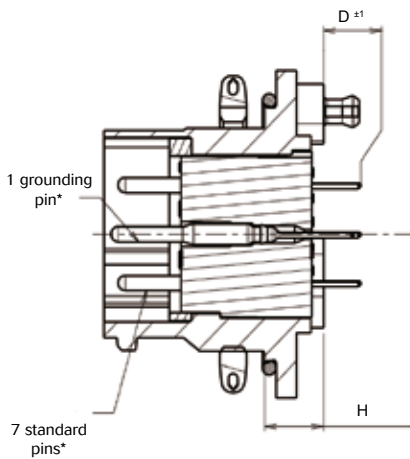

UTS7128PSEK9

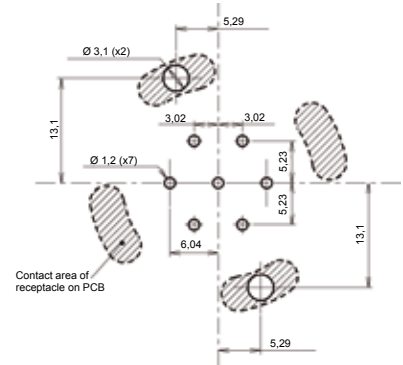

UTS7147PSEK9

Shell size	Part number	Nb of contacts	Ø A	B	C	D	E	F	G	H	I	J	Ø K
12	UTS7128PSEK9	8	19.0	3.0	25.0	3.6	3.2	31.8	27.0	6.5/6.8	4.0	21.2	22.5
14	UTS7147PSEK9	7	22.14	3.0	25.0	3.6	3.2	34.9	30.2	7.0	4.0	24.3	25.7

\* Only for the UTS7147PSEK9 version

Other arrangements upon request.

### Plating

- Plating for machined contacts
- Plating for stamped contacts

min 0.4 µm gold all over  
min 0.4 µm gold in contact area / 3 – 5 µm tin on solder tail

Other platings upon request

### PANEL CUT OUT

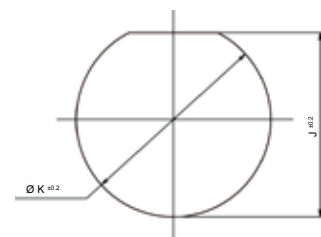

Note : all dimensions are in mm

**UTS : Your first choice in waterproof connectors !**

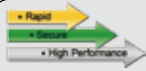

## PCB receptacle ... low profile with rapid installation features

**Low profile housing** to limit space between panel and PCB

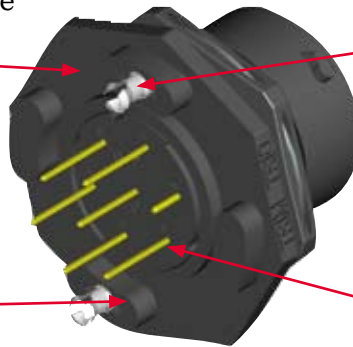

**Stand-offs** to allow cleaning after soldering

**Metal hold down clips**

- to lock the connector easily on the PCB and to release stress on solder joints
- Suitable for soldering in a metalised hole

**Pre-assembled PCB contacts**

- machined or stamped versions available
- different solder tails lengths possible
- different plating options

**UTS : Your first choice in waterproof connectors !**



# UTS discrete wire sealing

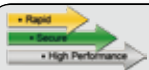

## Description

Using proven grommet technology from SOURIAU's extensive knowledge of harsh environments, the UTS connector with grommet guarantees a discrete wire sealing rated to IP67 (up to IP68 / IP69k for the easy handling version - with ergonomic backshell).

- UTS version with grommet is a range of connectors offering **IP67/69K water protection** thanks to the three sealing barriers where membranes are pierced when a termination wire is loaded. Sealing level can reach IP68 / IP69K with a backshell.
- UTS with grommet is available :
  - In 3 shell sizes up to 12 contact positions
  - With female plug & male receptacle
- Major benefits for the UTS version with grommet are :
  - A discrete sealing solution
  - Easy to assemble
  - Ideal for Outdoor / Indoor applications

**No filler plug needed !**

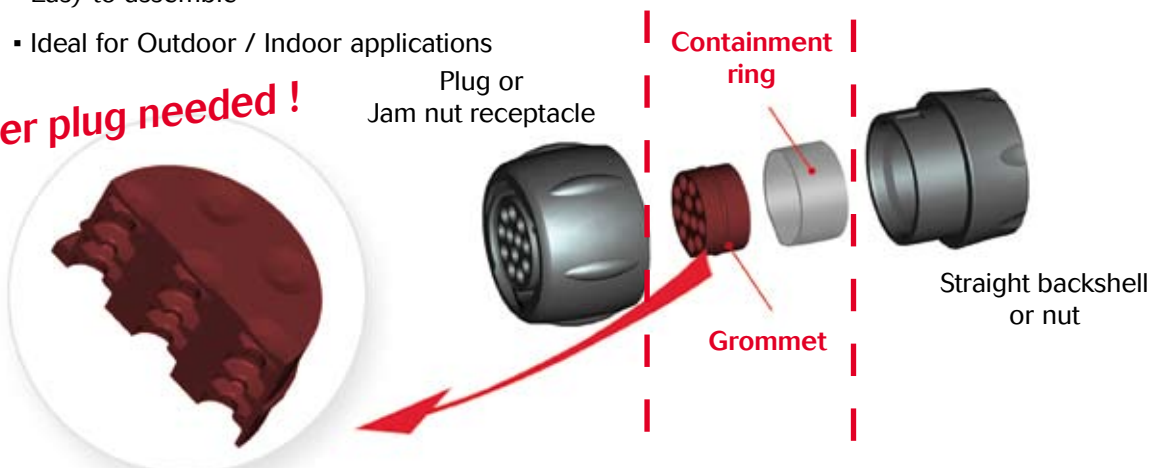

**UTS : Your first choice in waterproof connectors !**

# UTS discrete wire sealing



## Technical characteristics

### Mechanical

- Durability: 250 matings & unmatings
- Vibration resistance: Sinusoidal vibrations per CEI 60512-4 - from 10 to 2000 Hz 5 cycles 30 min. from -40°C to 105°C
- Thermal shock: 5 cycles 30 min. from -40°C to 105°C per MIL-STD 1344 method 1003
- Wire insulation: Ø from 1.7 to 3.0 mm

### Electrical

- Current per contact max.: 13A
- Insulation resistance: ≥ 5000 MΩ
- Test potential: 2000 VAC
- Working voltage: up to 400V class III, PD 2 as per VDE up to 500V as per UL1977 see page 7 for more details

### Environmental

- Operating temperature: -40°C to + 105°C
- Flammability rating: UL94-V0
- Salt spray: 500 hours
- Sealing (mated): IP67/69K (up to IP68/69K with the easy handling backshell)
- UV resistant: No mechanical degradation or important variation of color after 5 years of exposure in natural environment (equivalence exposure to sun and moisture as per ISO4892)

### Material

- Connectors + Backshell: Thermoplastic

### Contact accommodation

- UTS connectors accept TRIM TRIO® size 16 or size 20 (depending on arrangement) removable snap-lock contacts
- Contacts to be ordered separately - see from page 25 to 54

In accordance with UL requirements (UL ECBT2.E169916 and CSA ECBT8.E169916)

## Ordering information

<b>Type</b>		<b>UTS</b>	<b>6</b>	<b>G</b>	<b>JC</b>	<b>14</b>	<b>12</b>	<b>S</b>
		<b>UTS</b>	<b>7</b>	<b>G</b>	<b>N</b>	<b>14</b>	<b>12</b>	<b>P</b>
		<b>UTS</b>	<b>1</b>	<b>G</b>	<b>N</b>	<b>14</b>	<b>12</b>	<b>P</b>
<b>Connector type</b>								
1	In-line receptacle							
6	Cable plug							
7	Jam nut receptacle							
<b>Grommet</b>								
<b>Rear of the connector</b>								
JC	Backshell							
N	Nut							
<b>Insert arrangements</b>								
		10	12	14				
<b>Number of contacts</b>								
		4	8	7 - 12				
<b>Contact Gender</b>								
P	Pin contacts - only for receptacle							
S	Socket contacts - only for cable plug							

UTS : Your first choice in waterproof connectors !



# UTS discrete wire sealing

## UTS discrete wire sealing contacts arrangements

**Size 10**

**4**

Contacts :  
4 Ø 1.6 (#16)

**Size 12**

**8**

Contacts :  
8 Ø 1.6 (#16)

**Size 14**

**7**      **12**

Contacts\* :  
7 Ø 1.6 (#16)

Contacts :  
12 Ø 1.6 (#16)

All arrangements are available in plug and jam nut versions.

## Assembly Instructions

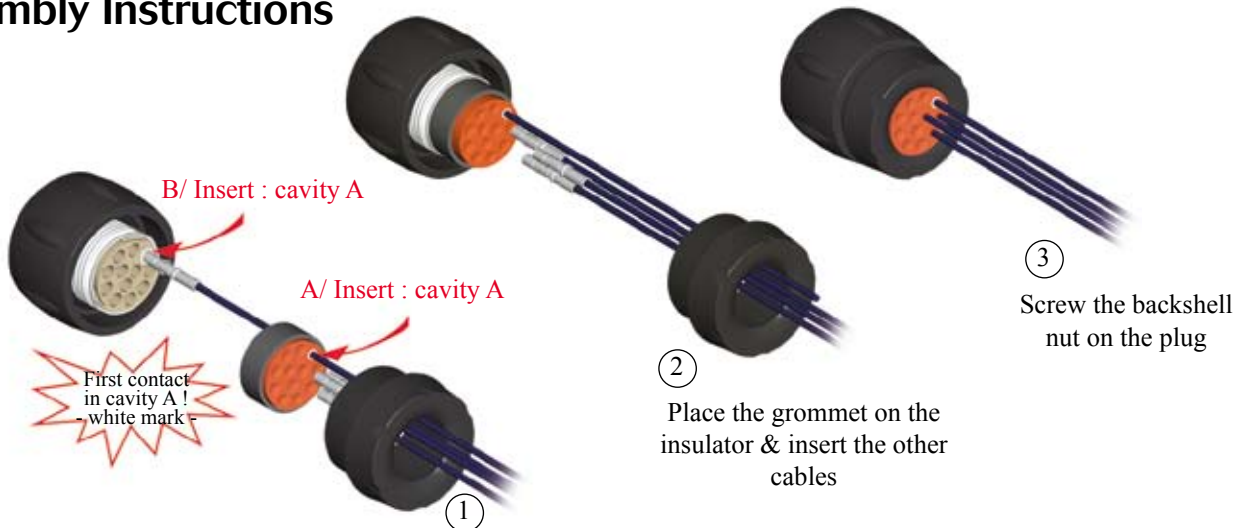

## Range presentation

**Female plug + Grommet + Backshell**

Shell size	Layout	Part numbers Female contact	A	B min.	Ø Cable range Standard seal	Ø Cable range Reducing seal	Hexagon D
10	10-4	UTS6GJC104S	26.2	61.5	2.5/8.0	1.5/5.0	18.5
12	12-8	UTS6GJC128S	29.7	64.5	5.0/12.0	3.0/9.0	24.0
14	14-7 14-12	UTS6GJC147S UTS6GJC1412S	34.6	70.0	7.0/14.0	5.0/12.0	26.0

Note : all dimensions are in mm / Coloured ring supplied as optional extra (see page 72).

**UTS : Your first choice in waterproof connectors !**

# UTS discrete wire sealing

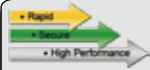

## Female plug + Grommet + Backshell nut

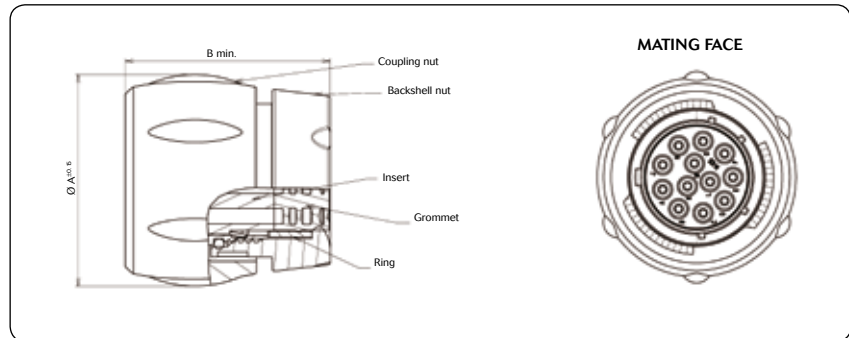

Shell size	Layout	Part numbers Female contact	A	B min.
10	10-4	UTS6GN104S	26.2	32.5
12	12-8	UTS6GN128S	29.7	32.3
14	14-7 14-12	UTS6GN147S UTS6GN1412S	34.6	32.0

Coloured ring supplied as optional extra (see page 72).

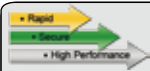

## Male jam nut receptacle + Grommet + Backshell

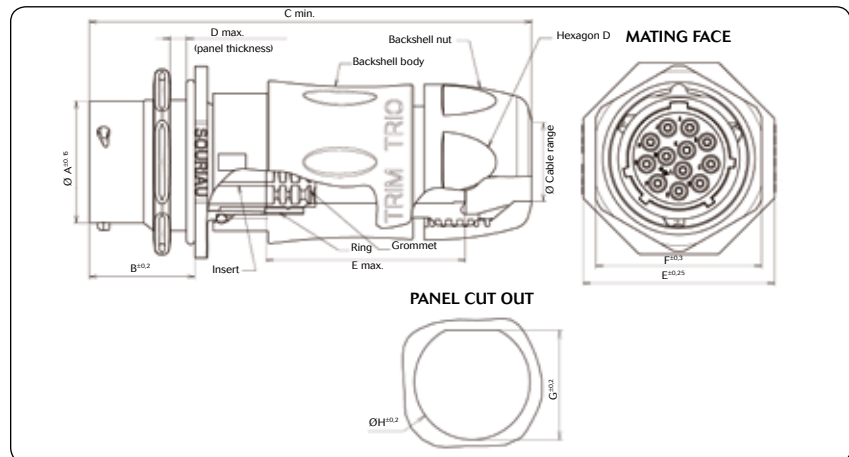

Shell size	Layout	Part numbers Male contact	Ø A	B	C	D	E <sup>±0.25</sup>	F	G	Ø H	Ø Cable range Standard seal	Ø Cable range Reducing seal	E
10	10-4	UTS7GJC104P	14.9	19.3	70.5	3.2	27.0	22.2	16.5	17.7	2.5 / 8	1.5 / 5	29.2
12	12-8	UTS7GJC128P	19.0	19.3	74.0	3.2	31.8	27.0	21.2	22.5	5 / 12	3 / 9	32.7
14	14-7 14-12	UTS7GJC147P UTS7GJC1412P	22.2	19.3	80.5	3.2	34.9	30.2	24.3	25.7	7 / 14	5 / 12	36.7

Note : all dimensions are in mm

**UTS : Your first choice in waterproof connectors !**



# UTS discrete wire sealing



## Male jam nut receptacle + Grommet + Backshell nut

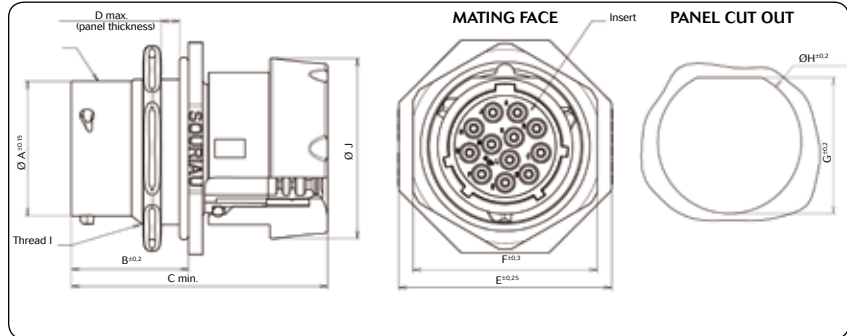

Shell size	Layout	Part numbers Male contact	Ø A	B	C	D	E	F	G	Ø H	Ø J
10	10-4	UTS7GN104P	14.9	19.3	41.0	3.2	27.0	22.2	16.5	17.7	22.0
12	12-8	UTS7GN128P	19.0	19.3	40.7	3.2	31.8	27.0	21.2	22.5	25.4
14	14-7 14-12	UTS7GN147P UTS7GN1412P	22.2	19.3	43.0	3.2	34.9	30.2	24.3	25.7	29.8



## Male In-line + grommet + backshell

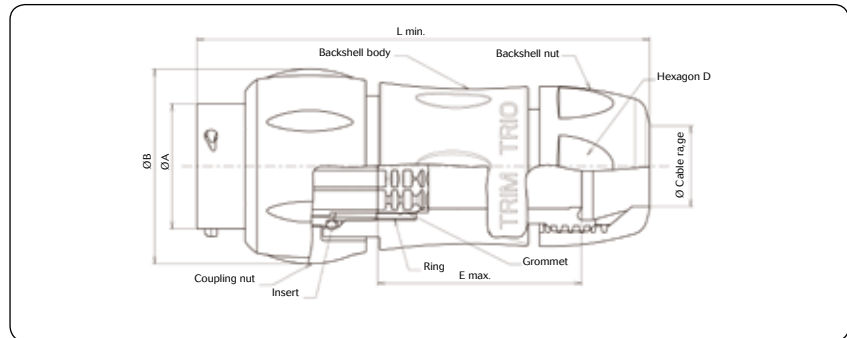

Shell size	Layout	Part numbers Male contact	Ø A	Ø B	L	Hexagon D	Ø Cable range Standard seal	Ø Cable range Reducing seal	E
10	10-4	UTS1GJC104P	14.9	26.2	70.7	27.0	2.5 / 8.0	1.5 / 5.0	30.0
12	12-8	UTS1GJC128P	19.0	29.7	74.5	31.8	5.0 / 12.0	3.0 / 9.0	33.5
14	14-7 14-12	UTS1GJC147P UTS1GJC1412P	22.2	34.6	80.5	34.9	7.0 / 14.0	5.0 / 12.0	37.6

Coloured ring supplied as optional extra (see page 72).

Note : all dimensions are in mm

**UTS : Your first choice in waterproof connectors !**

# UTS discrete wire sealing



• Rapid

• Simple

• High Performance

## Male In-line + grommet + backshell nut



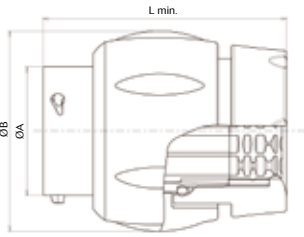

Shell size	Layout	Part numbers Male contact	Ø A	Ø B	L
10	10-4	UTS1GN104P	14.9	26.2	40.9
12	12-8	UTS1GN128P	19.0	29.7	40.9
14	14-7 14-12	UTS1GN147P UTS1GN1412P	22.2	34.6	43.0

Coloured ring supplied as optional extra (see page 72).

Note : all dimensions are in mm

**UTS : Your first choice in waterproof connectors !**

# RC/RM machined contacts size 16

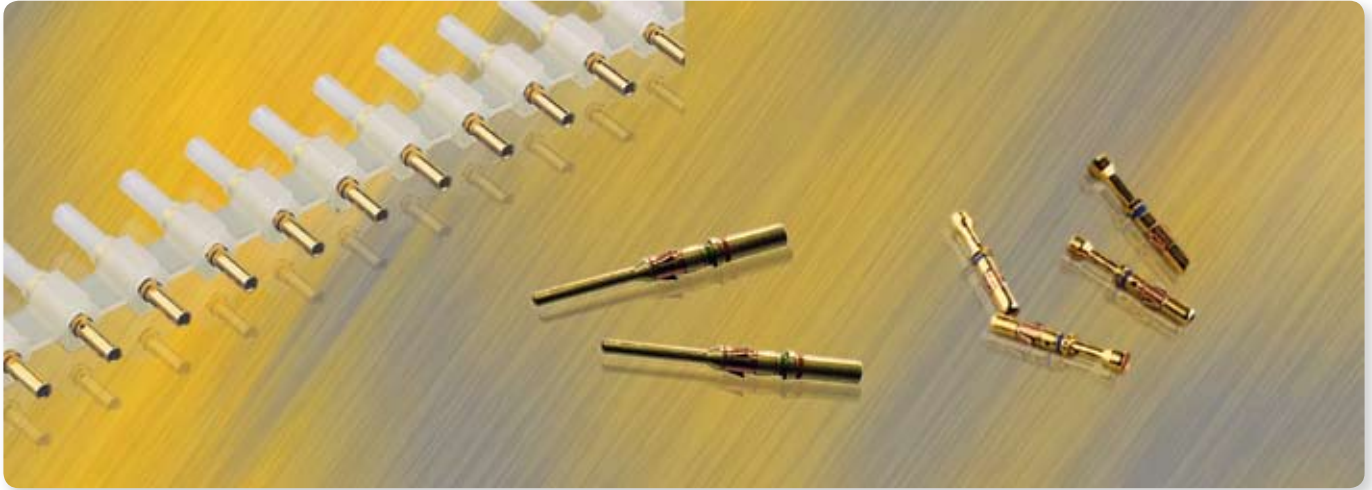

**Rapid**  
**Reliable**  
**High Performance**

## Description

**Size 16 machined contacts for TRIM TRIO® connectors**

Size 16 RM/RC .0625" (1.6mm) diameter contacts are precision machined crimp snap-in pins and sockets for heavy duty top performance requirements. The socket inner spring supplies high contact pressure to ensure low resistance contact between pin and socket. The socket contact features closed entry to prevent probe damage. Crimp barrels have insulation grips for vibration support and are provided with a wire stop and inspection hole.

Typical benefits are :

- Easy mounting & dismounting
- Excellent cable retention as well as contact retention in the cavity
- Easy wire identification with color coding

**UTS : Your first choice in waterproof connectors !**



# RC/RM machined contacts size 16



## Technical characteristics

### Electrical

- Current per contact max.: 13 A according to SAE 39029  
15 A according to NFF61030
- Contact resistance:  $\leq 3 \text{ M}\Omega$
- Contact retention in body: 110 N min.
- Individual insertion force: 3.5 N max.
- Individual withdrawal force: 0.55 N min

### Construction

- Contact body: High conductive copper alloy

### Plating table

- K (std) Min. 0.4 $\mu\text{m}$  gold all over, over nickel
- J Gold flash all over, over nickel
- N Min. 0.75 $\mu\text{m}$  gold all over, over nickel

Other plating, on request

### Connector accommodation

- TRIM TRIO® RC/RM machined contact size 16 can be used in any contact position in any connector from the TRIM TRIO® interconnection system - UTP, UTS, UTG, UTO, MBG, MS-M, MSG / MB, SMS, UTV - as well as in VGE1 and 838 connectors

## Ordering information

Type	(KRM)	16	M	23	(GE1)	K	-
	(KRC)	16	M	23	(GE7)	K	-
RM	Male contact bulk packing						
RC	Female contact bulk packing						
KRM	Male contact on plastic carrier strip						
KRC	Female contact on plastic carrier strip						
Wire size : 14, 16, 20, 24, 28							
Contact size 16 : .0625" (1.6mm) diameter contacts							
Design variation : Crimp barrel							
Types of contact							
No digit	Standard contact						
GE1	Longer contact						
GE3	Shorter contact (only male contact)						
GE7	Shorter contact (only female contact)						
Plating indication : See plating table							
Packing quantity							
No digit (std)	50 pcs bulk packing (RM/RC) 2000 pcs on reel (KRM/KRC)						
1000	1000 pcs bulk packing (RM/RC)						

## The RM/RC contact principle

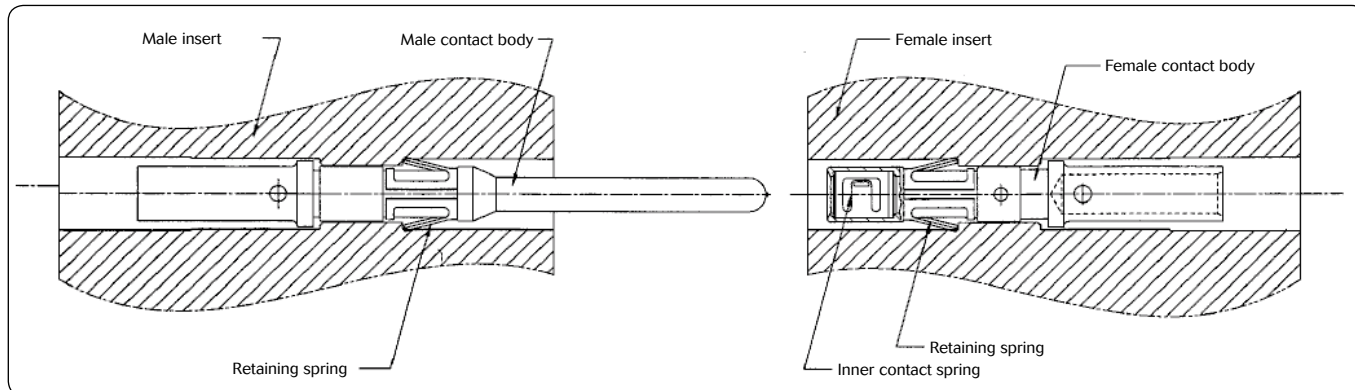

**UTS : Your first choice in waterproof connectors !**

# RC/RM machined contacts size 16



## Standard RM/RC crimp contacts: Contact size 16 - Pin Ø1.6mm (.063")

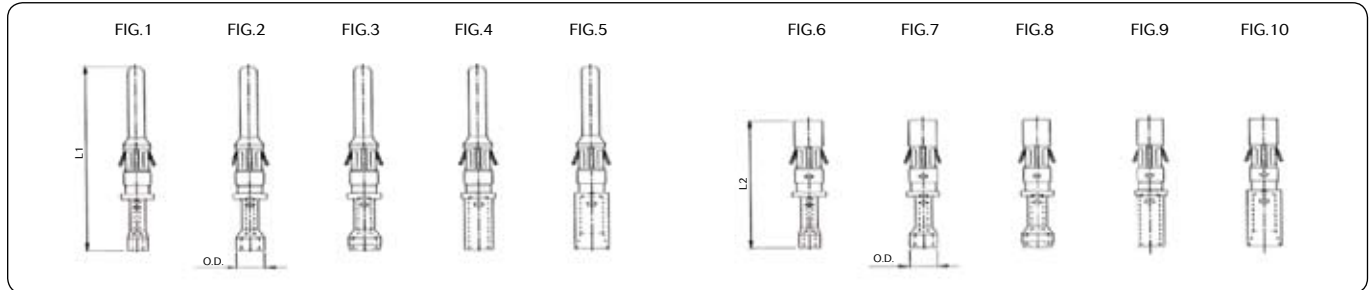

## Dimensional table - Standard RM/RC contacts

Part numbers				Wire size		Max. wire Ø	Max. insul. Ø	Wire strip length	O.D.**	L1	L2
Male contact	Fig.	Female contact	Fig.	AWG	mm <sup>2</sup>						
RM28M1(*)	1	RC28M1(*)	6	30-28	0.05-0.08	0.55	1.1	4.8	1.90	26.2	18.2
RM24M9(*)	2	RC24M9(*)	7	26-24	0.13-0.20	0.8	1.6		2.55		
RM20M13(*)	3	RC20M13(*)	8	22-20	0.32-0.52	1.18	1.8		2.92		
RM20M12(*)		RC20M12(*)					2.2	2.92			
RM16M23(*)	4	RC16M23(*)	9	20-16	0.52-1.50	1.80	3.2	7.1	2.55	26.2	18.2
RM14M50(*)	5	RC14M50(*)	10	16-14	1.5-2.5	2.05			3.10		
RM14M30(*)	5	RC14M30(*)	10	16-14	1.5-2.5	2.28			3.10		

\* Plating indication : See plating table  
 For machined contacts reeled on plastic carrier: put «K» in front of part number e.g. KRM16M13K

## Dimensional table - Crimp RM/RC contacts

### Comparison with standard RM / RC contacts

	GE1	GE3	GE7
RM contact (male contact)	+ 1 mm	-1 mm	-
RC contact (female contact)	+ 1.5 mm	-	-0.6 mm

### Contact selector guide

	Standard RC contact	RM*GE1	RC*GE7
Standard RC contact	X		
Standard RM contact			Last Mate, First Break
RM*GE1	First Mate, Last Break	X	

First Mate, Last Break contact can be used as grounding contact.

Note : all dimensions are in mm / \*\* Outer diameter

**UTS : Your first choice in waterproof connectors !**

# RC/RM machined contacts size 16



## Longer RM/RC contacts

Part numbers				Wire size		Max. wire Ø	Max. insul. Ø	Wire strip length	O.D.**	L1	L2
Male contact	Fig.	Female contact	Fig.	AWG	mm <sup>2</sup>						
RM28M1GE1(*)	1	RC28M1GE1(*)	6	30-28	0.05-0.08	0.55	1.1	4.8	1.90	27.2	19.7
RM24M9GE1(*)	2	RC24M9GE1(*)	7	26-24	0.13-0.20	0.8	1.6		2.55		
RM20M13GE1(*)	3	RC20M13GE1(*)	8	22-20	0.32-0.52	1.18	1.8		2.92		
RM20M12GE1(*)		RC20M12GE1(*)					2.2				
RM16M23GE1(*)	4	RC16M23GE1(*)	9	20-16	0.52-1.50	1.80	3.2	7.1	2.55		
RM14M50GE1(*)	5	RC14M50GE1(*)	10	16-14	1.5-2.5	2.05			3.10		
RM14M30GE1(*)	5	RC14M30GE1(*)	10			2.28					

\* Plating indication : See plating table

## Shorter RM/RC contacts

Part numbers		Wire size		Max. wire Ø	Max. insul. Ø	Wire strip length	O.D.**	L1
Male contact	Fig.	AWG	mm <sup>2</sup>					
RM28M1GE3*	1	30-28	0.05-0.08	0.55	1.1	4.8	1.90	25.2
RM24M9GE3*	2	26-24	0.13-0.20	0.8	1.6		2.55	
RM20M13GE3*	3	22-20	0.32-0.52	1.18	1.8		2.92	
RM20M12GE3*					2.2			
RM16M23GE3*	4	20-16	0.52-1.50	1.80	3.2	7.1	2.55	
RM14M50GE3*	5	16-14	1.5-2.5	2.05			3.10	
RM14M30GE3*	5			2.28				

\* Plating indication : See plating table

Part numbers		Wire size		Max. wire Ø	Max. insul. Ø	Wire strip length	O.D.**	L2
Female contact	Fig.	AWG	mm <sup>2</sup>					
RC28M1GE7*	6	30-28	0.05-0.08	0.55	1.1	4.8	1.90	17.6
RC24M9GE7*	7	26-24	0.13-0.20	0.8	1.6		2.55	
RC20M13GE7*	8	22-20	0.32-0.52	1.18	1.8		2.92	
RC20M12GE7*					2.2			
RC16M23GE7*	9	20-16	0.52-1.50	1.80	3.2	7.1	2.55	
RC14M50GE7*	10	16-14	1.5-2.5	2.05			3.10	
RC14M30GE7*	10			2.28				

\* Plating indication : See plating table

## Dimensional table - Handsolder RM/RC contacts

Part numbers		Wire size	
Male contact	Female contact	AWG	mm <sup>2</sup>
RM16SE0(*)	RC16SE4(*)	16-20	1.50-0.52

\* Plating indication : See plating table

Note : all dimensions are in mm / \*\* Outer diameter

**UTS : Your first choice in waterproof connectors !**

# RC/RM machined contacts size 16



## Crimptooling table

Size	Hand crimp tooling for loose contacts			Automatic crimp tooling for contacts on strip		Extraction tools
	Hand tools die set included	MH860		P107 Press		
		Positioner (not incl.)	Locator setting	Left side applicator KRM/KRC (not incl.)	Stripper unit (not incl.)	
R*28M1	Y16RCM	MH86164G	4/6	-	SC11	RX2025GE1
R*24M9			5/6	MLSP2763		
R*20M12/13			5/7	MLSP2764		
R*16M23			6/8	MLSP2765		
R*14M50	AF8 + TP1142	-	-	-	-	
R*14M30			-	-	-	
R*28M1GE1	Y16RCM	MH861686	4/6	-	-	
R*24M1GE1			5/6	-	-	
R*20*GE1			5/7	-	-	
R*16M23GE1			6/8	-	-	
R*14*GE1	*	-	-	-	-	
RM28M1GE3	Y16RCM	*	4/6	-	SC11	
RM24M1GE3			5/6	MLSP2763		
RM20*GE3			5/7	MLSP2764		
RM16M23GE3			6/8	MLSP2765		
RM14*GE3	*	-	-	-	-	
RC28M1GE7	Y16RCM	*	4/6	-	SC11	
RC24M1GE7			5/6	MLSP2763		
RC20*GE7			5/7	MLSP2764		
RC16M23GE7			6/8	MLSP2765		
RC14*GE7	*	-	-	-	-	

\* Consult factory

Note : all dimensions are in mm

**UTS : Your first choice in waterproof connectors !**

# RC/RM machined contacts size 16



**Nominal length (dim G) of dipsolder contacts out of connector**  
(contacts to be ordered separately)

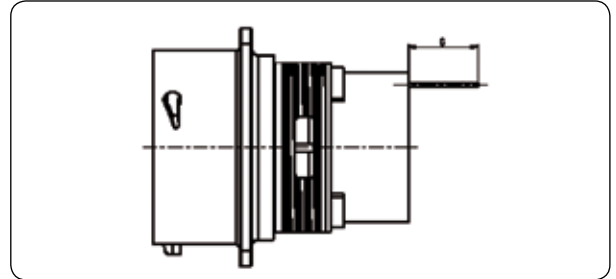

## UTS0 wall mounting receptacles

Connector sizes	Male contacts		Female contacts		
	RM20M12E8*	RM20M12E83*	RC20M12E8*	RC20M12E83*	RC20M12E84*
All sizes	5.2	10.3	5.2	10.4	13.9

\* Plating indication : See plating table

## UTS7 jam nut receptacles

Connector sizes	Male contacts		Female contacts		
	RM20M12E8*	RM20M12E83*	RC20M12E84*	RC20M12E85*	RC20M12E86*
10	4.1	9.2	4.65	7.15	7.95
12	4.1	9.2	4.65	7.15	7.95
14	4.1	9.2	5.35	7.85	8.65
16	4.1	9.2	4.65	7.15	7.95
18	4.1	9.2	4.65	7.15	7.95
20		4.85		3.4	4.2
22		4.85		2.7	3.5
24		3.35		1.3	2.1

For recommended PC-Board hole layout, please consult factory

\* Plating indication : See plating table

## The RM/RC contact packing



50 pcs bulk packing (standard)



1000 pcs bulk packing

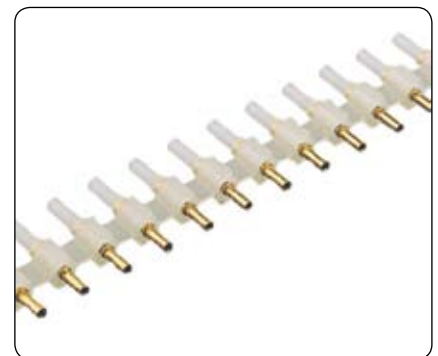

Reeled contacts on plastic carrier (qty 2000 pcs)

**UTS : Your first choice in waterproof connectors !**

# SC/SM Stamped & formed contacts size 16



• Rapid • Simple • High Performance	Description
	<p><b>Size 16 stamped and formed contacts for TRIM TRIO® connectors</b></p> <p>Size 16 SM/SC .0625" (1.6mm) diameter contacts are two piece strip formed crimp snap-in pin and sockets. These contacts consist of a crimp body made of high conductive copper alloy, and a stainless steel retaining spring featuring retention in the housing cavity and a closed entry socket to prevent probe damage.</p> <p>The contact with open barrel is standard available on strip and packaged with 3000 pcs on reel. This reel packaging combined with semi or even full automatic crimp tooling provides the added advantage of a lower installed cost.</p> <p>Typical features and benefits are :</p> <ul style="list-style-type: none"><li>▪ Made from high conductive copper alloy with gold or tin over nickel plate finish.</li><li>▪ Two piece construction with dual purpose spring which serves for contact retention and protects the body against damage.</li><li>▪ Contacts available on reel (standard) and in bulk packing (100 pcs).</li><li>▪ Suitable for automatic crimping thus lower installation cost.</li></ul>

**UTS : Your first choice in waterproof connectors !**

# SC/SM Stamped & formed contacts size 16



**Technical characteristics**

**Electrical**

- Current per contact max.: 13A
- Contact resistance: ≤ 6 MΩ
- Contact retention in body: 65 N min.
- Individual insertion force: 3.5 N max.
- Individual withdrawal force: 0.55 N min

**Construction**

- Contact body: High conductive copper alloy

**Plating table**

- S6 0.75 μm gold min. in contact area, flash on crimp barrel over nickel
- D70 (std) Gold flash all over, over nickel (standard)
- TK6 Preplated tin all over

**Connector accommodation**

- Any TRIM TRIO® size 16 contact can be used in any contact position in any connector in the TRIM TRIO® size 16 interconnection system : UTP, UTS, UTG, UTO, MBG, MS-M, MSG / MB, UTV

Note : Reeled contacts are for applicator with left side feeding.

## Ordering information

Type		SM	16	M	(L)	1	S6
SM Male contact		SC	16	M	(L)	1	S6
SC Female contact							
<b>AWG size</b> : 14, 16, 20, 24							
<b>Type of crimp barrel</b> : American crimp barrel							
<b>Packing</b>							
<b>No digit</b> Contacts on strip (qty 3000 per reel)							
L Preformed loose piece contact							
<b>Design variation</b>							
1 Only wire crimp for size 14 and 16							
1 Wire + insulation crimp for sizes 20 and 24							
11 Wire + insulation crimp for size 16							
<b>Plating indication</b> : See plating table							

**UTS : Your first choice in waterproof connectors !**

# SC/SM Stamped & formed contacts size 16

## Standard SM/SC crimp contacts: Contact size 16 - Pin Ø1.6mm (.063")

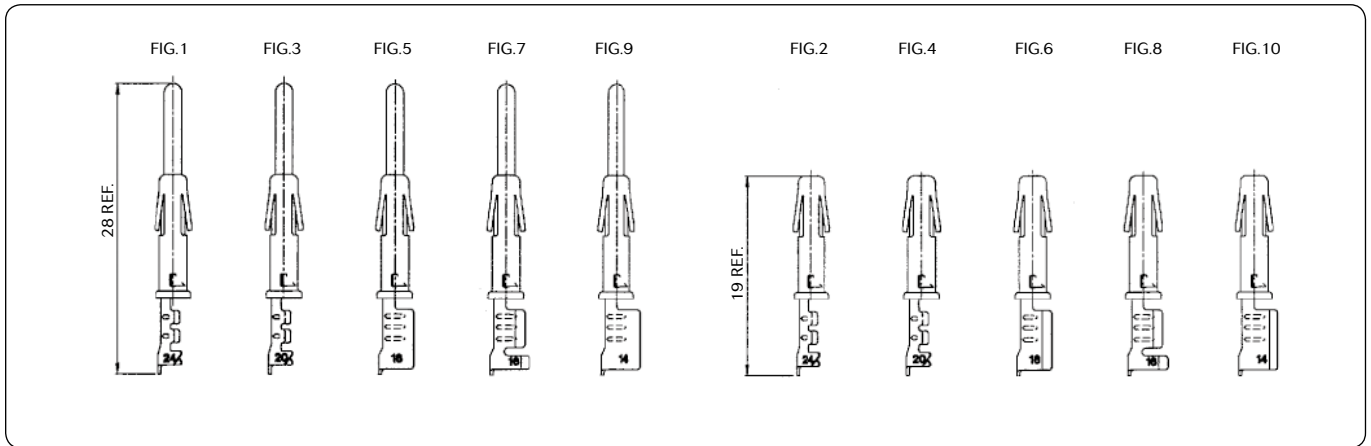

## Dimensional table

Part numbers : contacts on strip Loose pieces				Wire size		Insulation diameter	Wire strip length
Male contacts	Fig.	Female contacts	Fig.	AWG	mm <sup>2</sup>		
SM24M1S6 SM24ML1S6	1	SC24M1S6 SC24ML1S6	2	26 - 24	0.13 - 0.25	0.89 - 1.58	4.0
SM20M1S6 SM20ML1S6	3	SC20M1S6 SC20ML1S6	4	22 - 20	0.35 - 0.50	1.17 - 2.08	4.0
SM16M1S6 SM16ML1S6	5	SC16M1S6 SC16ML1S6	6	18 - 16	0.80 - 1.50	3.0	6.35
SM16M11S6 SM16ML11S6	7	SC16M11S6 SC16ML11S6	8	18 - 16	0.80 - 1.50	2.0 - 3.0	4.65
SM14M1S6 SM14ML1S6	9	SC14M1S6 SC14ML1S6	10	14	2.0	3.2	6.35

For other platings : See plating table

## Crimptooling table

Size	Hand crimp tooling for loose contacts y14MTV / y16SCM2 die set included	Automatic crimp tooling for contacts on strip		Extraction tools
		P107 Press Mini applicator (not incl.)	(Stripper - crimper)	
24	y14MTV or y16SCM2	MLS0318B	SC11	RX2025GE1
20		MLS0555A		
16M(L)11		MLS0356A		
16M(L)1		MLS1579		
14		MLS1047		

For detailed information on crimp tooling: See crimp tooling section

Note : all dimensions are in mm

**UTS : Your first choice in waterproof connectors !**



# Multipiece coaxial contacts size 16



## Description

### Size 16 Multipiece COAXIAL contacts for TRIM TRIO® connectors

Size 16 RMDX/RCDX Multipiece .0625" (1.6mm) diameter contacts are subminiature coaxial contacts to cover a wide range of subminiature coaxial and twisted pair cables.

They are suitable in applications where a mix of signal, power and coaxial cable terminations for low frequency, shielded signal and high frequency applications are needed.

The contact consists of an inner pin/socket and an outer male/female body.

The thermoplastic insulating bushing in the outer body is designed to accept and permanently retain the inner contact.

The outer ferrule hold the outer braid to the outer contact and act as an insulating support to ensure against bending and vibrating stresses.

The inner and the outer conductors are crimped individually, thereby enabling inspection of both critical crimp points.

Typical features and benefits are :

- The inner and outer conductors are crimped individually.
- The thermoplastic insulating bushing in the outer body is designed to accept and permanently retain the inner contact.
- Outer ferrule hold the outer braid to the outer contact and act as an insulating support to ensure against bending and vibration.

**UTS : Your first choice in waterproof connectors !**

# Multipiece coaxial contacts size 16



 <b>Technical characteristics</b>	
<p><b>Electrical</b></p> <ul style="list-style-type: none"> <li>• Operating voltage between inner / outer contact: 230 VDC</li> <li>• Test potential between inner / outer contact: 750 VAC 1 min.</li> <li>• Contact retention in body: 65 N min.</li> <li>• Contact voltage drop at 1A: 25m V max.</li> <li>• Isolation at 30 MHz: 140 db.</li> </ul> <p><b>Construction</b></p> <ul style="list-style-type: none"> <li>• Inner and outer contacts: High conductive copper alloy</li> <li>• Insulating bushing: Thermoplastic</li> </ul>	<p><b>Environmental</b></p> <ul style="list-style-type: none"> <li>• Operating temperature: -55°C to +125°C</li> </ul> <p><b>Plating table</b></p> <ul style="list-style-type: none"> <li>• Retaining spring: Nickel spring</li> <li>• Inner and outer contacts: D28: 0.75µm gold min. over nickel</li> </ul> <p><b>Connector accommodation</b></p> <ul style="list-style-type: none"> <li>• Any TRIM TRIO® size 16 contact can be used in any contact position in any connector in the TRIM TRIO® size 16 interconnection system : UTP, UTS, UTG, UTO, MS-M, MSG / MB, SMS</li> </ul>

## Ordering information

Type	RMDX RCDX	K10 K1	D28 D28
<p><b>Contact type</b></p> <p>RMDX Male subminiature coax</p> <p>RCDX Female subminiature coax</p>			
<p><b>Multipiece coax kit</b></p> <p>K10 Kit male coax</p> <p>K1 Kit female coax</p>			
<p><b>Plating indication</b></p>			

**UTS : Your first choice in waterproof connectors !**

# Multipiece coaxial contacts size 16

## MULTIPIECE Subminiature coax - Male contact for coaxial cable

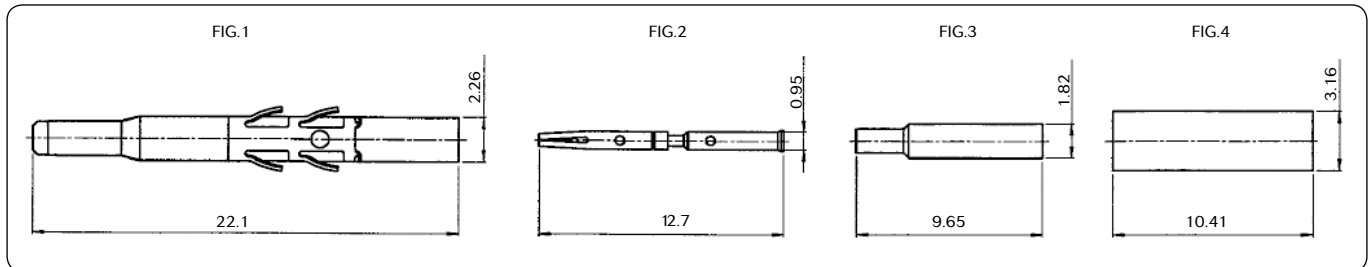

Type of coaxial cable	Contact for inner conductor				Contact for outer braid						Extraction tool
	Inner female contact		Crimp tool M10S1		Outer male contact		Hyring		Crimp tool M10S1		
	Part number	Fig.	Die set	Stop bushing	Part number	Fig.	Part number	Fig.	Die set	Stop bushing	
RG161U RG179A/U RG179B/U RG187U RG188/U RG174/U RG178A/U RG196U	RFD26L1D28	2	S23D2	SL46D2	RMDX602D28	1	YOC074	4	S22-1	SL47-1	RX2025GE1
S26D2											
S23D2			YOC074 + RMDXB0553				4 3				

Kit reference RMDXK10D28 includes RMDX602D28 + RFD26L1D28 + YOC074 + RMDXB0553 and are packed in plastic bag.

## MULTIPIECE Subminiature coax - Female contact for coaxial cable

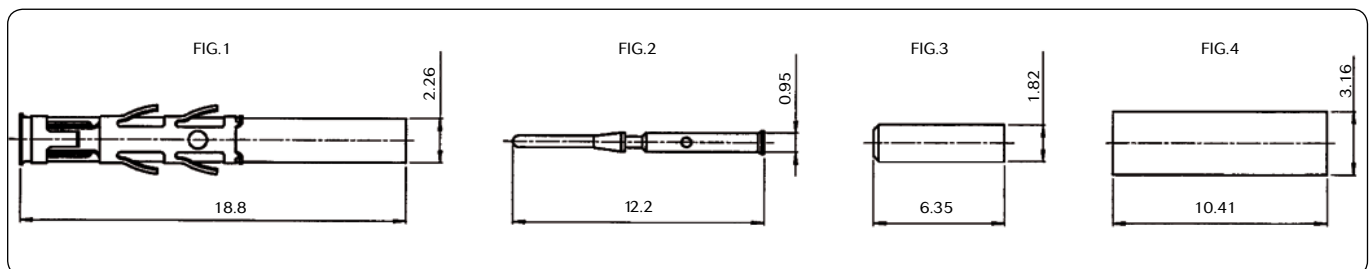

Type of coaxial cable	Contact for inner conductor				Contact for outer braid						Extraction tool
	Inner male contact		Crimp tool M10S1		Outer female contact		Hyring		Crimp tool M10S1		
	Part number	Fig.	Die set	Stop bushing	Part number	Fig.	Part number	Fig.	Die set	Stop bushing	
RG161U RG179A/U RG179B/U RG187U RG174/U RG188/U RG174/U RG178A/U RG196U	RMD26L1D28	2	S23D2	SL46D2	RCDX602D28	1	YOC074	4	S22-1	SL47-1	RX2025GE1
S26D2			YOC074								
S23D2			YOC074 + RCDXB0551				4 3				

Kit reference RCDXK1D28 includes RCDX602D28 + RMD26L1D28 + YOC074 + RCDXB0551 and are packed in plastic bag.

**UTS : Your first choice in waterproof connectors !**

# Multipiece coaxial contacts size 16

## MULTIPIECE Subminiature coax - Male contact for coaxial cable

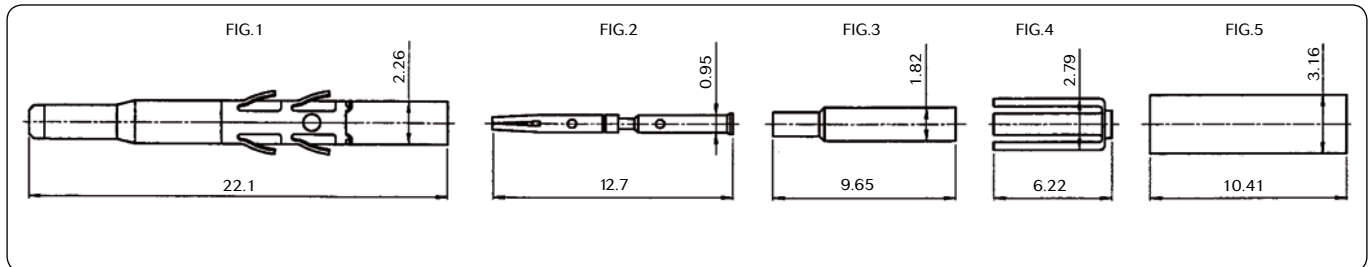

Type of coaxial cable	Contact for inner conductor				Contact for outer braid						Extraction tool
	Inner female contact		Crimp tool M10S1		Outer male contact		Hyring		Crimp tool M10S1		
	Part number	Fig.	Die set	Stop bushing	Part number	Fig.	Part number	Fig.	Die set	Stop bushing	
2 #24 stranded MIL-W-16878 Type B 2 #24 solid MIL-W-76 Type LW 2 #26 stranded MIL-W-76 Type LW or MIL-W16878 type B & E 2 #28 solid MIL-W-8 1822/3	RFD26L1D28	2	S26D2	SL46D2	RMDX602D28	1	YOC074	5	S221	SL471	RX2025GE1
							RMDXB0554	3			
			YORX090	4							
			YOC074	5			S47				
RMDXB0553	3										
YORX090	4										

## MULTIPIECE Subminiature coax - Female contact for coaxial cable

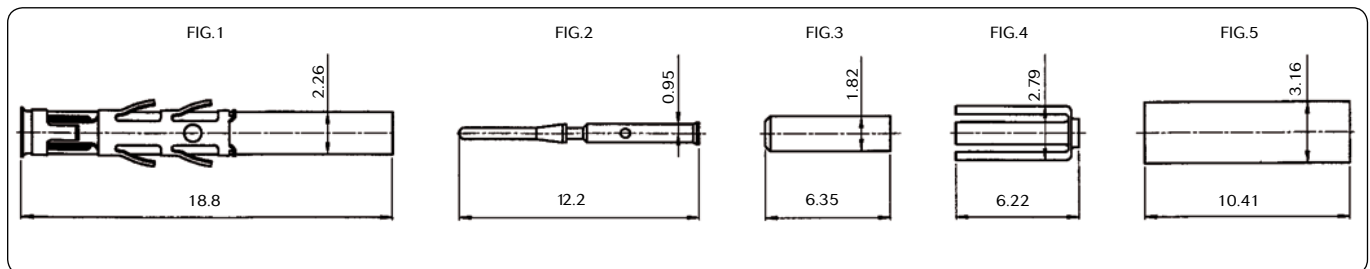

Type of coaxial cable	Contact for inner conductor				Contact for outer braid						Extraction tool
	Inner male contact		Crimp tool M10S1		Outer female contact		Hyring		Crimp tool M10S1		
	Part number	Fig.	Die set	Stop bushing	Part number	Fig.	Part number	Fig.	Die set	Stop bushing	
2 #24 stranded MIL-W-16878 Type B 2 #24 solid MIL-W-76 Type LW 2 #26 stranded MIL-W-76 Type LW or MIL-W16878 type B & E 2 #28 solid MIL-W-8 1822/3	RMD26L1D28	2	S26D2	SL46D2	RCDX602D28	1	YOC074	5	S221	SL471	RX2025GE1
							RCDXB0552	3			
			YORX090	4							
			YOC074	5			S47				
RMDXB0551	3										
YORX090	4										

UTS : Your first choice in waterproof connectors !

# Monocrimp coaxial contacts size 16



 Rapid Simple High Performance	Description
	<p><b>Size 16 Monocrimp COAXIAL contacts for TRIM TRIO® connectors</b></p> <p>Size 16 RMDX/RCDX Monocrimp .0625" (1.6mm) diameter contacts are one-piece monocrimp subminiature coaxial contacts to cover a wide range of subminiature coaxial and twisted pair cables.</p> <p>They provide cost effective solutions in applications where a mix of signal, power and coaxial cable terminations for low frequency, shielded signal and high frequency applications are needed.</p> <p>Monocrimp one-piece coaxial contacts offer high reliability plus the economic advantage of a 95% reduction in installation time over conventional assembly methods currently in use.</p> <p>Typical features and benefits are :</p> <ul style="list-style-type: none"><li>▪ The monocrimp one-piece coaxial contacts offer high reliability plus the economic advantage of a 95% reduction in installation time over conventional assembly methods.</li><li>▪ This economy is achieved by simultaneously crimping of both the inner and outer conductor.</li></ul>

**UTS : Your first choice in waterproof connectors !**

# Monocrimp coaxial contacts size 16



 <b>Technical characteristics</b>	
<p><b>Electrical</b></p> <ul style="list-style-type: none"> <li>• Operating voltage between inner / outer contact: 230 VDC</li> <li>• Test potential between inner / outer contact: 450 VAC 1 min.</li> <li>• Contact retention in body: 65 N min.</li> <li>• Contact voltage drop at 1A: 30m V max.</li> <li>• Isolation at 30 MHz: 140 db.</li> </ul> <p><b>Construction</b></p> <ul style="list-style-type: none"> <li>• Inner and outer contacts: High conductive copper alloy</li> <li>• Insulating bushing: Thermoplastic</li> </ul>	<p><b>Environmental</b></p> <ul style="list-style-type: none"> <li>• Operating temperature: -55°C to +125°C</li> </ul> <p><b>Plating table</b></p> <ul style="list-style-type: none"> <li>• Retaining spring: Nickel</li> <li>• Inner and outer contacts: D28: 0.75µm gold min. over nickel</li> </ul> <p><b>Connector accomodation</b></p> <ul style="list-style-type: none"> <li>• Any TRIM TRIO® size 16 contact can be used in any contact position in any connector in the TRIM TRIO® size 16 interconnection system : UTP, UTS, UTG, UTO, MS-M, MSG / MB, SMS</li> </ul>

## Ordering information

Type	RMDX60 RCDX60	36 36	D28 D28
<b>Contact type</b> RMDX Male subminiature coax RCDX Female subminiature coax			
Monocrimp design variation			
Plating indication			

**UTS : Your first choice in waterproof connectors !**

# Monocrimp coaxial contacts size 16

## MONOCRIMP Subminiature coax

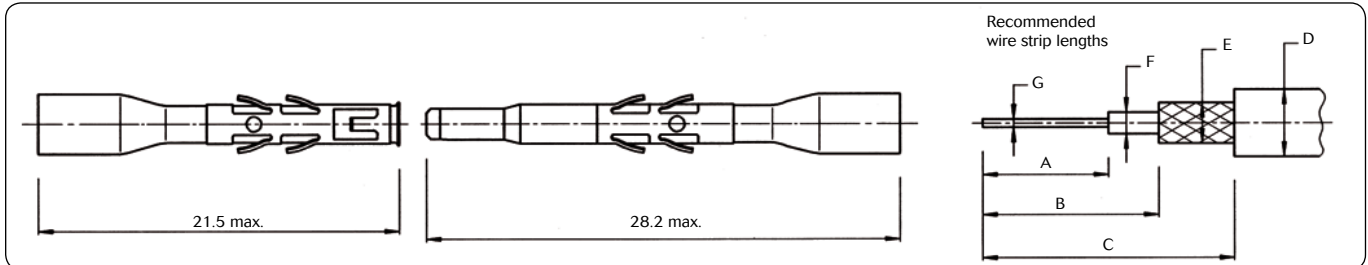

Part numbers	AWG inner conduct.	Cable type	Coax dimensions				Coax strip lengths			Crimp tool M10S1		Extraction tool
			D max.	E	F	G	A	B	C	Die set not incl.	Stop bushing not incl.	
RMDX6050D28 RCDX6050D28	30	-	2.64	2.11	1.70	0.30	5.1	6.35	8.9	S80	SL105	RX2025GE1
RMDX6050D28 RCDX6050D28		-	2.29	1.63	1.22		4.2	5.97	8.5	S87		
RMDX6032D28 RCDX6032D28	28	-	2.90	1.29	1.91	0.38	5.1	6.35	11.7	S80		
RMDX6024D28 RCDX6024D28	-	1.78	1.37	0.96	0.48				8.9	S82		
RMDX6032D28 RCDX6032D28	26	RG174/U	2.92	2.24	1.52	0.48			11.7	S80		
RMDX6026D28 RCDX6026D28		-	3.05	2.44	1.96	0.41			8.9	S82		
RMDX6036D28 RCDX6036D28		RG188A/U	2.79	1.98	1.52	0.51			11.7	S80		
RMDX6036D28 RCDX6036D28		RG316/U	2.72									

\* M10SG8 consists of die set, stop bushing and M10S1 tool

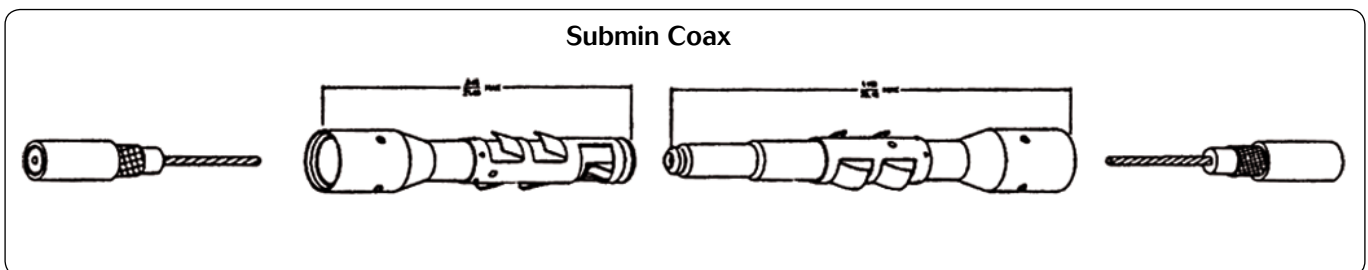

Note : all dimensions are in mm

**UTS : Your first choice in waterproof connectors !**

# Monocrimp coaxial contacts size 16

## MONOCRIMP Twisted pair

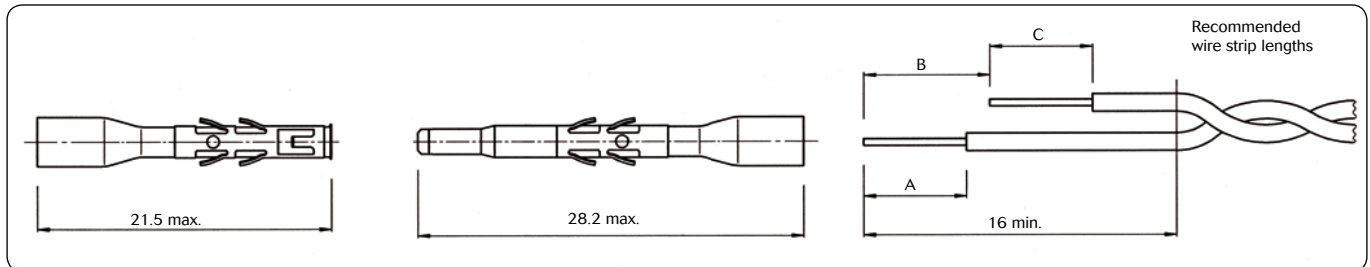

Part number	AWG inner conduct.	Dia. outer	Cable strip lengths			Crimp tool M10S1		Extraction tool
			A	B	C	Die set not incl.	Stop bushing not incl.	
Male								
Female								
RMDX6019D28	26 (19 x 0.10)	1.25	4.7	6.0	4.0	M10SG8* Crimping kit		RX2025GE1
RCDX6019D28	24 (7 x 0.20)	1.25						
	24 (19 x 0.13)	1.45						
RMDX6031D28	26 (7 x 0.16)	0.70				S80	SL105	
RCDX6031D28								

\* M10SG8 consists of die set, stop bushing and M10S1 tool

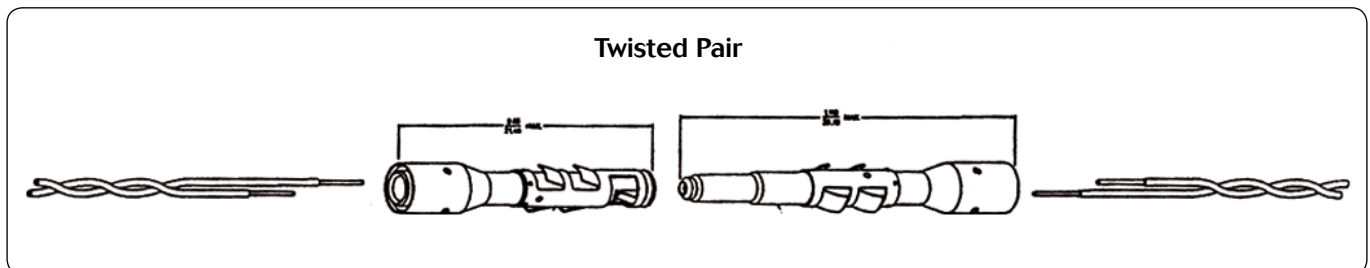

Note : all dimensions are in mm

**UTS : Your first choice in waterproof connectors !**

# Fibre optic contacts size 16

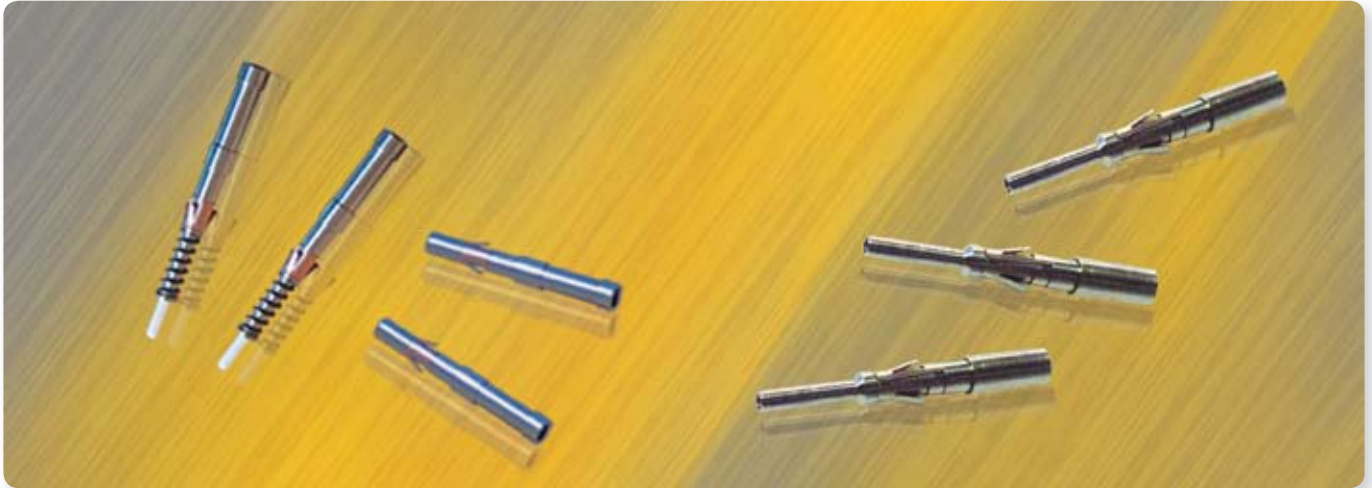

## Description

### Size 16 Fibre optic contacts for TRIM TRIO® connectors

Size 16 Fibre optic contacts are optical contacts designed for the integration of optical links in all TRIM TRIO® cable connectors.

The Fibre optic contacts are designed to accommodate:

- Plastic Optical Fibre (POF)  
1 mm core and 2.2 mm jacket
- Plastic Clad Fibre (PCF)  
230µm core and 2.2 mm jacket
- Multimode Silica Fibre  
62.5/125µm type 2.0 mm max. jacket
- Singlemode Silica Fibre  
9/125µm type 2.0 mm jacket

Typical features and benefits are :

- Socket contact is spring loaded to avoid any air gap between the two optical faces.
- Low insertion loss is provided by high precision pieces.
- Single jumpers, multiway harness and active device housings can be supplied regarding customer requirement.

**UTS : Your first choice in waterproof connectors !**

# Fibre optic contacts size 16



## Technical characteristics

### Performance

• Fibre type:	POF/PCF	Multimode	Singlemode
• Wave length:	650 nm	62.5/125µm	9/125µm
• Optical insertion loss (typ.):	2 dB max.	1300 nm	1310 nm
• Jacketed external diameter:	2.2mm	< 0.5 dB	< 0.35 dB
• Temperature range:	-25°C to +70°C	2.0mm max.	2.0mm max.
• Cable retention:	49N	-25°C to +70°C	-25°C to +70°C
• Mating cycles without cleaning:	50		
• Max. mating cycles:	500		

### Construction

- Contact body: Copper alloy

### Connector accommodation

Any TRIM TRIO® size 16 contact can be used in any contact position in any connector in the TRIM TRIO® size 16 interconnection system : UTP, UTS, UTG, UTO.

## Ordering information

### POF Contacts (Plastic Optical Fibre)

Male contact	RMPOF1000
Female contact	RCPOF1000B

### PCF Contacts (Plastic Clad Fibre)

Male contact	RMPCF230
Female contact	RCPOF230B

### Silica Contacts - Multimode

Male contact	RMMMMOFA
Female contact	RCMMOFA

### Silica Contacts - Monomode

Male contact	RMSMOFA
Female contact	RCSMOFA

## Tooling kit



### POF Contact (Plastic Optical Fibre)

#### STANDARD TOOLING KIT - P/N 80MS0004

The **standard tooling kit** is made of the part numbers below that can be ordered separately as well.

Part numbers	Descriptions
80WD005	Stripping tool
80WD0025	Automatic stripping tool for Ø 0.5 mm, 0.6 mm, 0.7 mm & 3.8 mm
80WM0006	Ruler
80WP0005	Polishing plate
80WP0013	Non slip base (to hold the polishing plate)
80WP0014	Polishing disk (grain size 9µm)
80WP0018	Polishing tool
80WP0019	Polishing disk (grain size 30µm)
80WS0002	Crimping plier

#### SPECIFIC TOOLING LIST - can be ordered only separately

Part numbers	Descriptions
80WG0010	Needle
80WG0015	Capsule
80WG0016	Syringe
80WN0005	Dry air spray
80WN0006	Optical paper
80WN0012	Dropping bottle
80WN0008	Wiping solvent

**UTS : Your first choice in waterproof connectors !**

# Fibre optic contacts size 16



## PCF Contact (Plastic Clad Fibre)

### STANDARD TOOLING KIT - P/N 80MG0039

Descriptions
Stripping tool for Ø 2.2 mm
Kevlar scissors
Stripping tool for Ø 0.25 mm
Alumina blade
Polishing tool
Press fit tool
Microscope

Descriptions
Polishing disk (grain size 9µm)
Polishing disk (grain size 0.3µm)
Curing oven
Polishing plate
Non slip base (to hold the polishing plate)
Glue



## Multimode Contact - Silica

### STANDARD TOOLING KIT - P/N 80MG0027

The *standard tooling kit* is made of the part numbers below that can be ordered separately as well.

Part numbers	Descriptions
80WC0001	Aramid yarn scissors
80WC0003	Cutter
80WC0004	Alumina blade
80WD0008	Stripping tool for Ø 0.20 mm
80WD0010	Stripping tool for Ø 0.25 mm
80WD0014	Stripping tool for Ø 0.60 mm
80WD0025	Automatic stripping tool for Ø 0.5 mm, 0.6 mm, 0.7 mm & 3.8 mm
80WM0006	Ruler
80WP0005	Polishing plate
80WP0013	Non slip base (to hold the polishing plate)
80WT0008	Curing oven
80WT0009	Protective tube

### SPECIFIC TOOLING LIST - can be ordered only separately

Part numbers	Descriptions
80WD0036	Stripping tool for Ø 0.9 mm & 0.25 mm
80WD0005	Stripping tool for Ø 2.2 mm & 1.5 mm
80WL0001	Microscope x400
80WL0008	Microscope adaptor
80WP0025	Polishing tool
80WS0002	Crimping tool
80WT0005	Contact support for polymerisation
80WG0010	Needle
80WG0014	Glue
80WG0015	Capsule
80WG0016	Syringe
80WN0005	Dry air spray
80WN0006	Optical paper
80WN0012	Dropping bottle
80WP0014	Polishing disk (grain size 9µm)
80WP0015	Polishing disk (grain size 0.3µm)

UTS : Your first choice in waterproof connectors !



## Notes

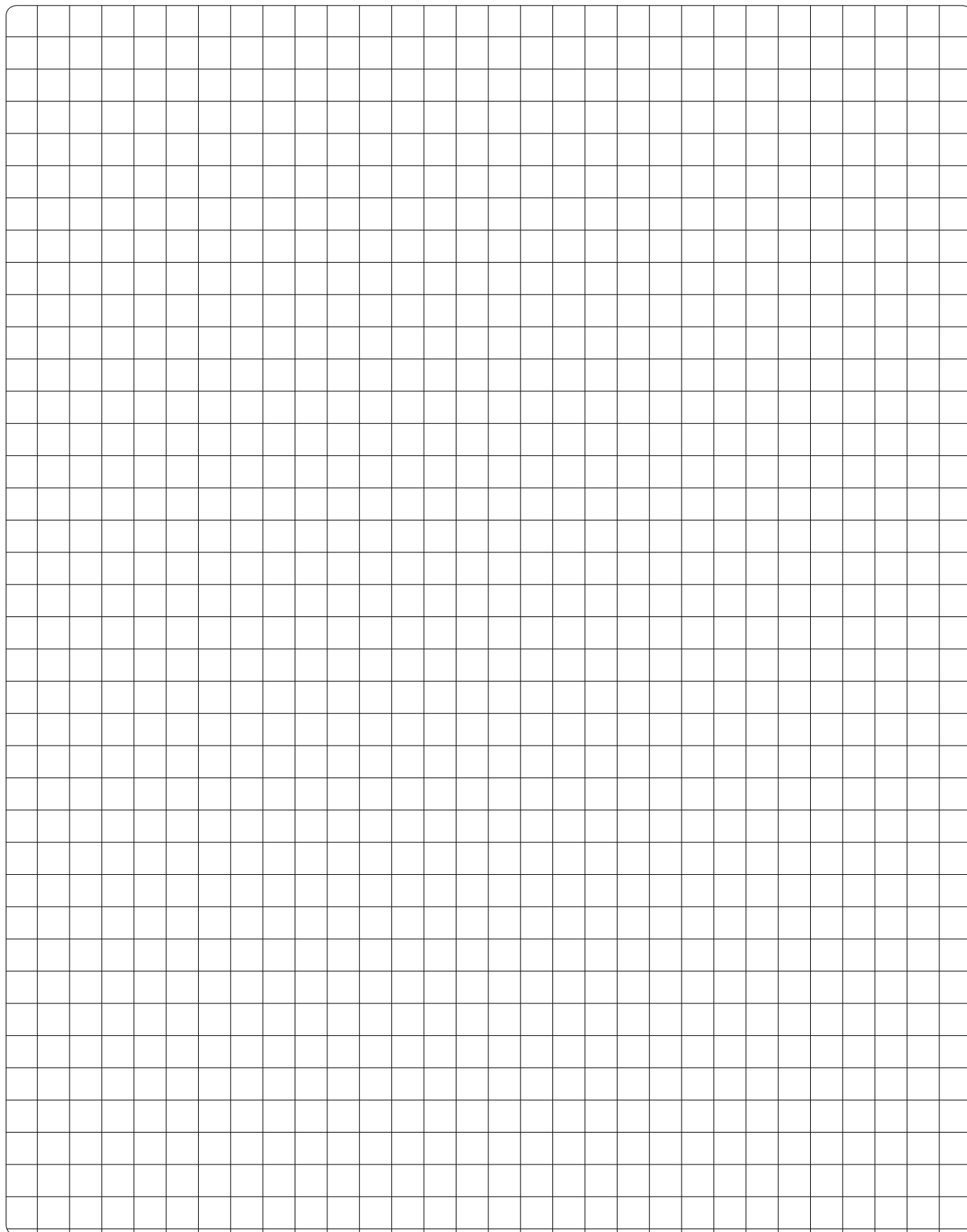

# Machined / Stamped & formed contacts size 20

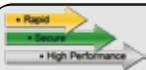
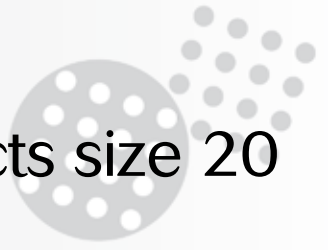

## Description

### Size 20 contacts for TRIM TRIO® connectors

Size 20 contacts with a .040" (1.0mm) pin diameter are two piece crimp snap-in contacts in pin and socket version available in:

- **Machined version**
- **Stamped and formed version**
- **Machined dip solder contacts**
  - 50A7
  - 5016

and designed for heavy duty top performance requirements. These contacts consist of a crimp/solder body made of high conductive copper alloy, and a stainless steel retaining spring featuring retention in the housing cavity and a closed entry socket to prevent probe damage.

Crimp contacts accommodate AWG20 through AWG26 wire and the crimp barrels.

Typical features and benefits are :

- Made from high conductive copper alloy with gold plate finish.
- Two piece construction with dual purpose spring which serves for contact retention and protects the body against damage.
- Stamped and formed contacts packaging: on reel: 3000 pcs / in bulk packing: 100 pcs in plastic bag.
- Machined crimp and dip solder contacts packaging: 50 pcs in plastic box.

**UTS : Your first choice in waterproof connectors !**

# Machined / Stamped & formed contacts size 20



## Technical characteristics

### Performance

	Machined	Stamped and formed
• Current per contact max.:	7.5 A	5 A
• Contact resistance:	≤ 6 mΩ	≤ 15 mΩ
• Dielectric withstanding voltage:	1500 V Rms min.	
• Contact retention in body:	90 N max.	
• Contact engagement force:	5 N max.	
• Contact separation force:	0.3 N min.	
• Plating:	0.40µm gold over nickel	0.75µm gold over nickel

### Construction

- Contact body: High conductive copper alloy

### Connector accommodation

Any size 20 contacts for UTO, UTS and UTG connectors can be used in any contact position.

## Ordering information

	Contact type		Part numbers	AWG	Section mm <sup>2</sup>	Insulation diameter
Machined crimp		Pin	RM24W3K	26 - 24	0.13 - 0.20	1.58 max.
			RM20W3K	22 - 20	0.32 - 0.52	1.58 max.
			RM18W3K	20 - 18	0.50 - 0.93	2.10 max.
		Socket	RC24W3K	26 - 24	0.13 - 0.20	1.58 max.
			RC20W3K	22 - 20	0.32 - 0.52	1.58 max.
			RC18W3K	20 - 18	0.50 - 0.93	2.10 max.
Stamped and formed crimp		Reeled loose piece Pin	SM24W3S26	26 - 24	0.13 - 0.25	0.89 - 1.58
			SM24WL3S26			
		Reeled loose piece Socket	SM20W3S26	22 - 20	0.35 - 0.50	1.17 - 2.08
			SM20WL3S26			
		Reeled loose piece Pin	SC24W3S25	26 - 24	0.13 - 0.25	0.89 - 1.58
			SC24WL3S25			
		Reeled loose piece Socket	SC20W3S25	22 - 20	0.35 - 0.50	1.17 - 2.08
			SC20WL3S25			
Machined Dip solder		Pin	50A7	RMW50A7K	For solder tail details see next page	
			5016	RMW5016K		
	Socket	50A7	RCW507AK			
		5016	RCW5016K			

Note : all dimensions are in mm

UTS : Your first choice in waterproof connectors !

# Machined / Stamped & formed contacts size 20

## Crimptooling table

Size	Hand crimp tooling for loose contacts		Automatic crimp tooling for contacts on strip		Extraction tools	
	Y14MTV / Y16SCM2 die set included	MH860 Positioner (not incl.)	Locator setting	P107 Press Left side applicator KRM/KRC (not incl.)		Stripper unit (not incl.)
RM24W3K	Y16RCM or AF8 + TP120	MH86301	5/6	-	-	RX20D44
RM20W3K			5/7			
RM18W3K			6/8			
RC24W3K			5/6			
RC20W3K			4/7			
RC18W3K			6/8			
SM24W3S26 SM24WL3S26	Y14MTV	-	-	MLS0318B	SC11	
SM20W3S26 SM20WL3S26				MLS0555A		
SC24W3S25 SC24WL3S25				MLS0318B		
SC20W3S25 SC20WL3S25				MLS0555A		
RMW50A7K	For solder tail details, see below					
RMW5016K						
RCW507AK						
RCW5016K						

## Nominal length (dim G) of dip solder contacts out of connector

(contacts to be ordered separately)

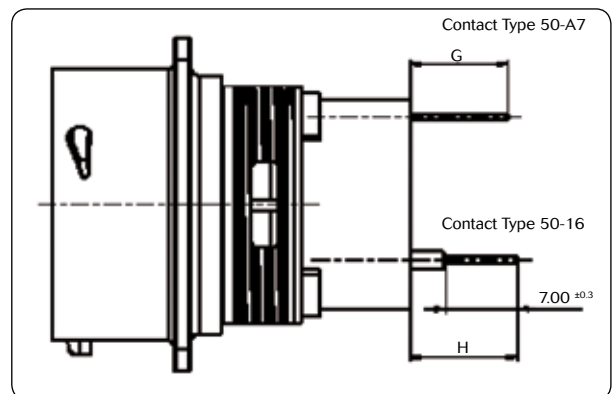

## UTS7 jam nut receptacle connectors

Size	Male contact		Female contact	
	RMW50A7K	RMW5016K	RCW50A7K	RCW5016K
10	9.51	10.41	2.4	3.04
12				
14				
16				
18	5	6	-	-
20				
22				
24	3.6	4.6		

\* Plating indication : see plating table / Note : all dimensions are in mm

**UTS : Your first choice in waterproof connectors !**



# Power contacts



## Description

TRIM TRIO® connectors also offer possibilities to use or combine power contacts with the standard size 16 signal contacts into the same housing.

It offers customers to reduce the number of connectors when combining signal and high current applications into one connector.

The signal cavities accept the full range of TRIM TRIO®:

- Size 16 contacts for applications up till 13 A
- Size 20 contacts for applications up till 7.5 A

Power cavities will either accept:

- **Size 12 contacts for applications up till 26A**
- **Size 8 contacts for applications up till 44A**

Pin and socket contacts are machined crimp snap-in and sockets for heavy duty top performance requirements.

*For any specific power arrangement, please consult us.*

**UTS : Your first choice in waterproof connectors !**



# Power contacts



## Technical characteristics

### Performance

	Contacts #12 (Ø2.4)	Contacts #8 (Ø3.6)
• Current per contact max.:	26 A	44A
• Contact resistance:	≤ 5 mΩ	≤ 5 mΩ

### Construction

• Contact body: High conductive copper alloy

### Plating

K	0.4µm gold min. all over, over nickel
A	3µm silver all over

### Connector accommodation

Power contacts can be used in the existing power arrangements of the UTS - see catalog pages 6/7 - UTP, UTG, UTO, UTV and SMS connectors - see pages in the TRIM TRIO® catalog.

## Contacts #12 (Ø2.4 mm)

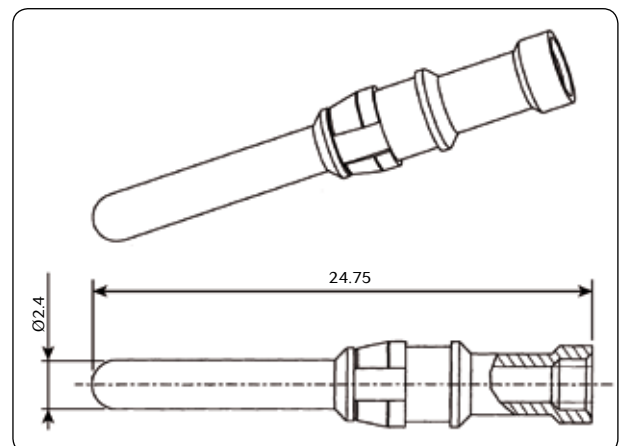
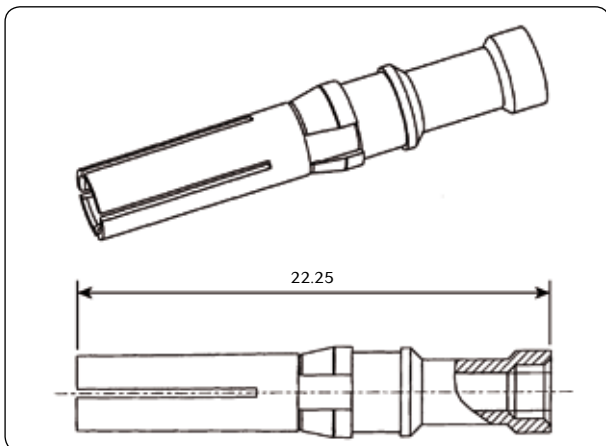

## Contacts #8 (Ø3.6 mm)

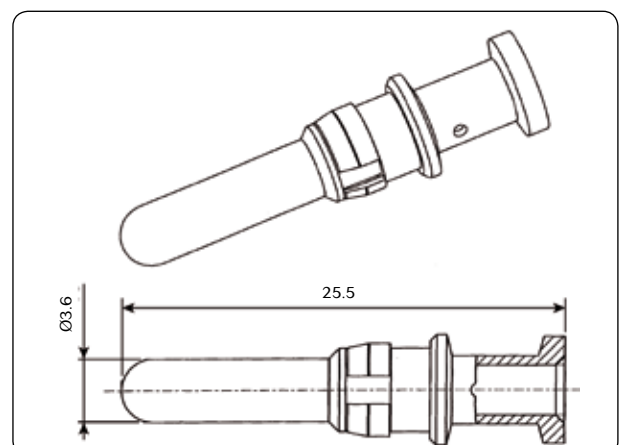
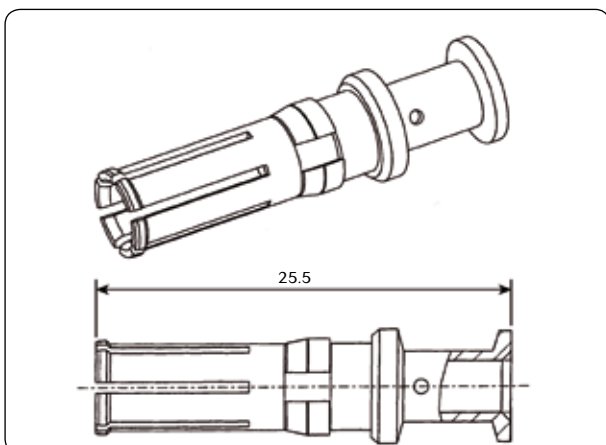

Note : all dimensions are in mm

**UTS : Your first choice in waterproof connectors !**

# Power contacts



## Ordering information

Part numbers		Contact size	Contact Ø	Cable			Crimp tooling	Locator setting	Locator	Extraction tooling	Plating
Pin	Socket			Section		Insulator Ø					
				mm <sup>2</sup>	AWG	mm					
82911459NA	82911458A	#12	2.4	0.5	20	4.9	M317	VGE10077A	51060210924	Ag	
82911461NA	82911460A			0.75-1.0	18						
82911463NA	82911462A			1.5	16						
82911465NA	82911464A			2.5	14						
82911467NA	82911466A			4.0	12						
82911459NK	82911458K	#12	2.4	0.5	20	4.9	M317	VGE10077A	51060210924	Au	
82911461NK	82911460K			0.75-1.0	18						
82911463NK	82911462K			1.5	16						
82911465NK	82911464K			2.5	14						
82911467NK	82911466K			4.0	12						
82913601A	82913600A	#8	3.6	1.5	16	6.5	M317	VGE10078A	51060210936	Ag	
82913603A	82913602A			2.5	14						
82913605A	82913604A			4.0	12						
82913607A	82913606A			6.0	10						
82913609A	82913608A			10.0	8						

Note : all dimensions are in mm

**UTS : Your first choice in waterproof connectors !**



## Notes

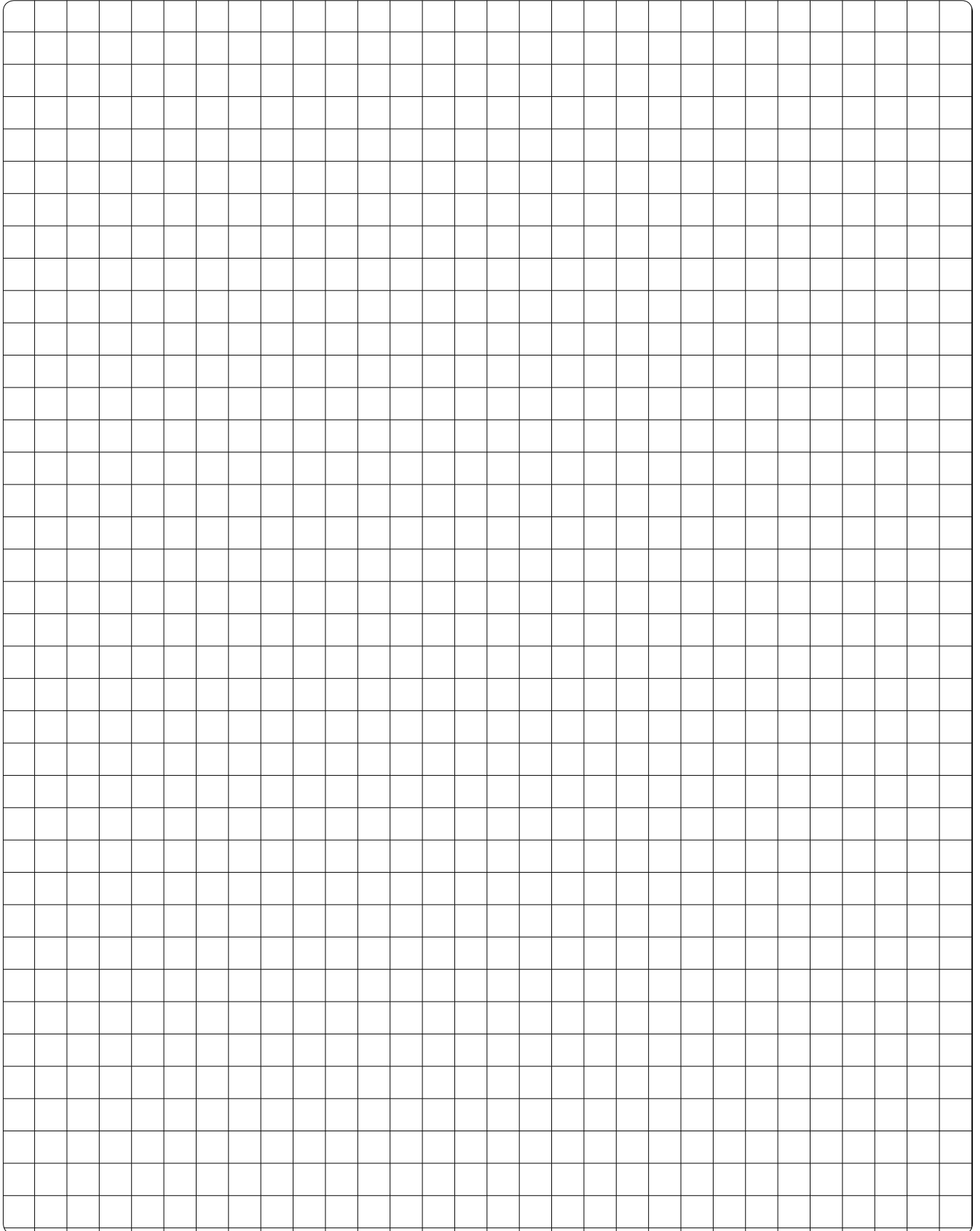

# UTS Hi seal

**SEALED UNMATED**  
**MIL-DTL-26482**  
**COMPATIBLE**



## Description

### Dynamic IP68/IP69K - Waterproof connectors in mated and unmated condition

- UTS Hi seal connector is a range of lightweight industrial plastic circular connectors compatible with MIL-DTL-26482 connectors. It offers **Dynamic IP68/IP69K** water protection in **both mated & unmated conditions**.
- Available :
  - in 5 shell sizes,
  - up to 21 contact positions
  - with multiple polarization options.
- Connectors are standard supplied with preassembled handsolder contacts. For dipsolder or crimp contacts, please consult factory.



**UTS : Your first choice in waterproof connectors !**

# UTS Hi seal

**SEALED UNMATED**  
**MIL-DTL-26482**  
**COMPATIBLE**



## Major features & benefits



Extreme sealing performance in **unmated** conditions

### In **unmated** conditions

- ➡ Dynamic IP68  
Connector will remain IP68 even when:
  - Pulling on the cable
  - Bending the cable

- ➡ Dynamic IP69K  
Connector withstands high pressure water cleaning



### In **mated** conditions

- ➡ Dynamic IP68  
Connector will remain IP68 even when:
  - Pulling on the cable
  - Bending the cable

- ➡ Dynamic IP69K  
Connector withstands high pressure water cleaning

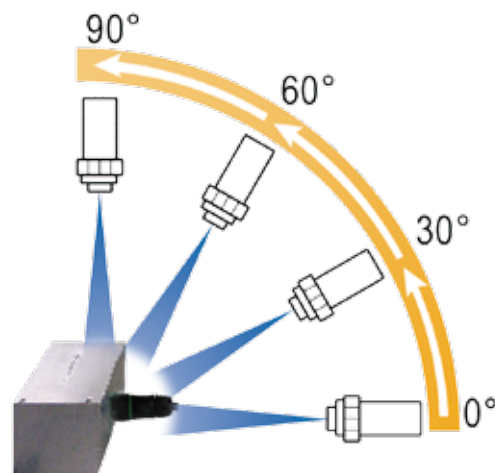
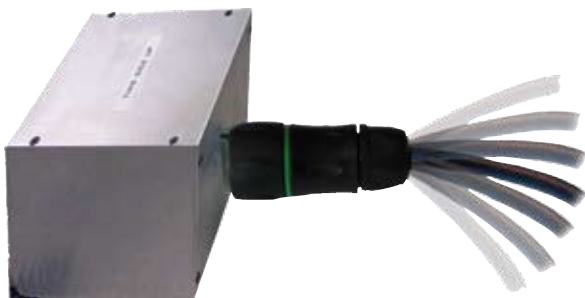

**UTS : Your first choice in waterproof connectors !**

# UTS Hi seal

**SEALED UNMATED  
MIL-DTL-26482  
COMPATIBLE**



**Intermateable with MIL-DTL-26482 or equivalents**

UTS Hi seal connectors are fully intermateable and interchangeable with MIL-DTL-26482 connectors or equivalents such as : BS 9522-F0017, NFC 93422, HE 301B, VG 95328.

**Intermateable with MIL-DTL-26482 connectors (or equivalents)**

**Hand solder contacts**

Hand solder contacts require no special skills or tooling. Only a standard soldering-bolt is needed to fit the wires to the contacts, making it incredibly user friendly and suitable for any field installation.

Hand solder contact

Wire

Stranded wire  
or  
Solid wire

**UTS : Your first choice in waterproof connectors !**

# UTS Hi seal

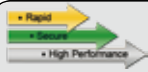

## Technical characteristics

### Mechanical

- Durability: 250 matings & unmatings
- Vibration resistance: Sinusoidal vibrations per CEI 60512-4 - from 10 to 2000 Hz
- Thermal shock: 5 cycles 30 min. from -40°C to 105°C per MIL-STD1344 method 1003

### Electrical

- Current per contact max.: Size 16: 13A  
Size 20: 7.5A
- Insulation resistance:  $\geq 5000 \text{ M}\Omega$  under 500Vcc at 25°C
- Test potential: 1500 Veff between contacts size 20  
2300 Veff between contacts size 16 according to MIL-DTL-26482
- Working voltage: 600 V - contacts size 20  
1000 V - contacts size 16 according to MIL-DTL-26482

### Environmental

- Operating temperature: -40°C to + 105°C
- Sealing (mated/unmated): Dynamic IP68 - under water for 1 week, 1 bar  
Dynamic IP69K per DIN 40050
- Salt spray: 500 hours
- RoHS compliant & conform to the Chinese standard SJ/T1166-2006 (Chinese RoHS equivalent)
- UV resistant: No mechanical degradation or important variation of color after 5 years of exposure in natural environment (equivalence exposure to sun and moisture as per ISO4892)

### Material

- Housing + Backshell: Thermoplastic UL94-V0
- Insert: Elastomer
- Contacts: Copper alloy - gold plated  
Other platings on request



## Ordering information

Connector family	UTS	7	-	8	E	2	P	-
	UTS	6	JC	8	E	2	S	-
<b>Body variation</b>								
6	Cable plug + backshell							
7	Jam nut receptacle							
0	Square flange receptacle							
<b>Backshell</b> : JC = Backshell (only for plug) / No digit = No backshell (only for plug)								
<b>Shell size</b> : 8, 10, 12, 14, 18								
<b>Contact type</b>								
E = Handsolder contacts / R = Crimp contacts* / D = PC tail contacts*								
<b>Insert arrangement</b> - see next page								
<b>Contact gender</b> : P = Pin contacts / S = Socket contacts								
<b>Insert rotation</b> : No digit = Normal / W, X, Y, Z = Different orientations - see page 60								

\* Please consult factory

**UTS : Your first choice in waterproof connectors !**

# UTS Hi seal

**SEALED UNMATED  
MIL-DTL-26482  
COMPATIBLE**



## UTS Hi seal contacts arrangements

**Size 8**

<b>2</b>	<b>3</b>	<b>3A/98</b>	<b>4</b>	<b>33</b>
Contacts : 2 Ø 1 (#20)	Contacts : 3 Ø 1 (#20)	Contacts : 3 Ø 1 (#20)	Contacts : 4 Ø 1 (#20)	Contacts : 3 Ø 1 (#20)

**Size 10**

<b>6</b>	<b>7</b>	<b>98</b>
Contacts : 6 Ø 1 (#20)	Contacts : 7 Ø 1 (#20)	Contacts : 6 Ø 1 (#20)

**Size 12**

<b>2</b>	<b>3</b>	<b>8</b>	<b>10</b>	<b>14</b>
Contacts : 2 Ø 1.6 (#16)	Contacts : 3 Ø 1.6 (#16)	Contacts : 8 Ø 1 (#20)	Contacts : 10 Ø 1 (#20)	Contacts : 14 Ø 1 (#20)

**Size 14**

<b>5</b>	<b>12</b>	<b>15</b>	<b>18</b>	<b>19</b>
Contacts : 5 Ø 1.6 (#16)	Contacts : 8 Ø 1 (#20) 4 Ø 1.6 (#16)	Contacts : 14 Ø 1 (#20) 1 Ø 1.6 (#16)	Contacts : 18 Ø 1 (#20)	Contacts : 19 Ø 1 (#20)

**Size 18\***

<b>11</b>	<b>32</b>	<b>30</b>
Contacts : 11 Ø 1.6 (#16)	Contacts : 32 Ø 1 (#20)	Contacts : 29 Ø 1 (#20) 1 Ø 1.6 (#16)

\* Please consult factory

**UTS : Your first choice in waterproof connectors !**

# UTS Hi seal

**SEALED UNMATED  
MIL-DTL-26482  
COMPATIBLE**



## Insert orientation\*

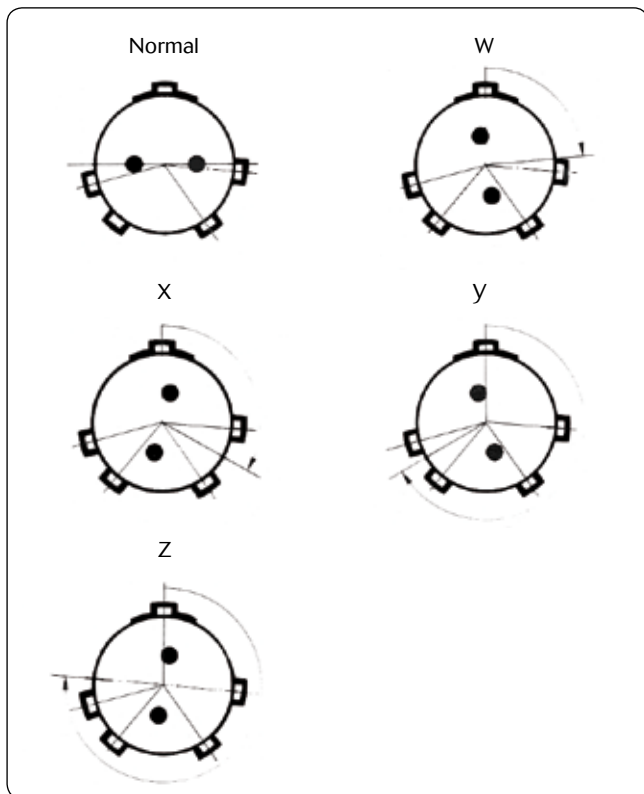

Shell sizes	layouts	angle in degrees			
		W	X	y	Z
8	2	58	122	-	-
	3	60	210	-	-
	3A (98)*	60	210	-	-
	4	45	-	-	-
	33	90	-	-	-
10	6	90	-	-	-
	7*	90	-	-	-
	98	90	180	240	270
12	3	-	-	180	-
	8	90	112	203	292
	10	60	155	270	295
	2	-	-	-	-
14	14*	45	-	-	-
	5	40	92	184	273
	12	43	90	-	-
	15	17	110	155	234
	18	15	90	180	270
18	19	30	165	315	-
	11	62	119	241	340
	32	85	138	222	265
	30	180	193	285	350

\* Insert rotated in body (viewed from front face of male insert)

\* 8-98 layout, W and X non standard orientations / 10-7 & 12-14 layouts, X non standard orientation

## Range presentation

• Rapid  
• Durable  
• High Performance

### Square flange receptacle with handsolder contacts

Shell size	Part numbers		A	B	C	Ø D	E	F	G	Ø I	Ø J
	Male contact	Female contact									
8	UTS08E -- P -	UTS08E -- S -	21.5	2.3	11.7	12.0	15.1	21.0	3.2	15.5	12.5
10	UTS010E -- P -	UTS010E -- S -	21.5	2.3	11.7	15.0	18.3	23.8	3.2	17.3	15.1
12	UTS012E -- P -	UTS012E -- S -	21.5	2.3	11.7	19.0	20.6	26.2	3.2	21.8	18.2
14	UTS014E -- P -	UTS014E -- S -	21.5	2.3	11.7	22.2	23.0	28.6	3.2	25.0	21.5
18	UTS018E -- P -*	UTS018E -- S -*	21.5	2.5	11.7	28.5	27.0	33.3	3.2	31.8	27.8

Note : all dimensions are in mm / \* Please consult factory

**UTS : Your first choice in waterproof connectors !**

# UTS Hi seal

**SEALED UNMATED  
MIL-DTL-26482  
COMPATIBLE**



## Jam nut receptacle with handsolder contacts

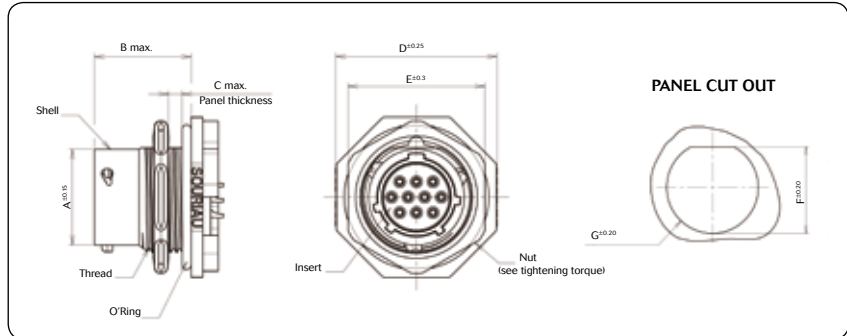

Shell size	Part numbers		Ø A	B	C	D	E	F	Ø G	Tightening torque
	Male contact	Female contact								
8	UTS78E -- P -	UTS78E -- S -	12.0	19.3	3.2	24.0	19.3	13.75	14.6	2 Nm
10	UTS710E -- P -	UTS710E -- S -	14.9	19.3	3.2	27.0	22.2	16.5	17.7	3 Nm
12	UTS712E -- P -	UTS712E -- S -	19.0	19.3	3.2	31.8	27.0	21.2	22.5	4 Nm
14	UTS714E -- P -	UTS714E -- S -	22.2	19.3	3.2	34.9	30.2	24.3	25.7	5 Nm
18	UTS718E -- P -*	UTS718E -- S -*	28.5	19.3	3.2	41.3	36.6	30.6	32.0	5 Nm



## Cable plug with handsolder contacts

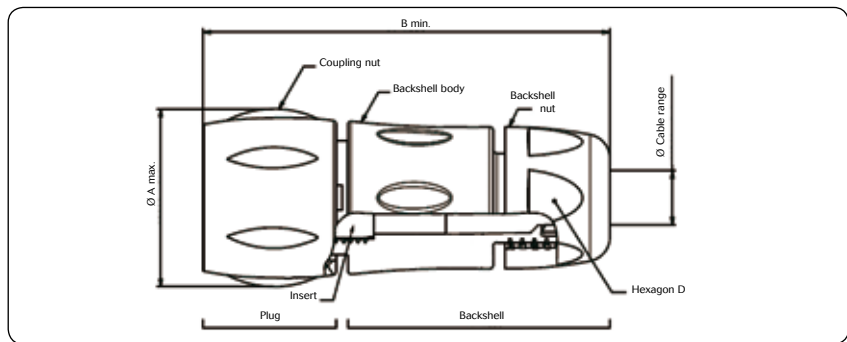

Shell size	Part numbers		Ø A	B	Ø Cable range Standard seal	Ø Cable range Reducing seal	Hexagon D
	Male contact	Female contact					
8	UTS6JC8E -- P -	UTS6JC8E -- S -	22.5	54.0	2.5 / 6.5	1.5 / 5.0	16.0
10	UTS6JC10E -- P -	UTS6JC10E -- S -	26.7	63.2	2.5 / 8.0	1.5 / 5.0	18.5
12	UTS6JC 2E -- P -	UTS6JC12E -- S -	30.2	66.7	5.0 / 12.0	3.0 / 9.0	24.0
14	UTS6JC14E -- P -	UTS6JC14E -- S -	35.1	71.5	7.0 / 14.0	5.0 / 12.0	26.0
18	UTS6JC18E -- P -*	UTS6JC18E -- S -*	42.0	81.3	9.0 / 18.0	7.0 / 16.0	33.0

Coloured ring supplied as optional extra (see page 72).

Note : all dimensions are in mm / \* Please consult factory

**UTS : Your first choice in waterproof connectors !**

# UTS Hi seal

**SEALED UNMATED  
MIL-DTL-26482  
COMPATIBLE**



## Cable plug without backshell

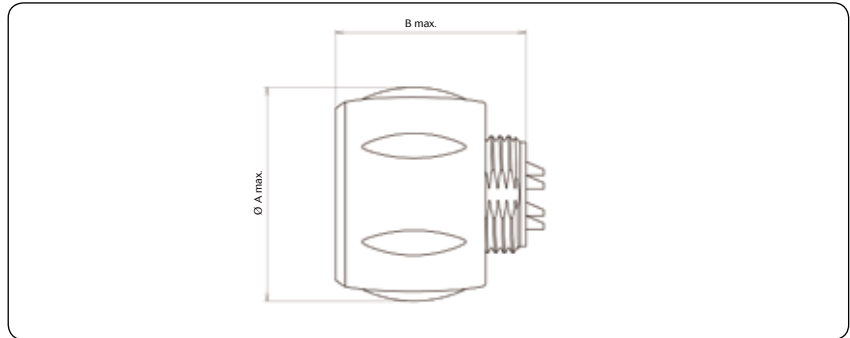

Shell size*	Part numbers		Ø A	B
	Male contact	Female contact		
8	UTS68E - - P -	UTS68E - - S -	22.5	21.3
10	UTS610E - - P -	UTS610E - - S -	26.7	23.6
12	UTS612E - - P -	UTS612E - - S -	30.2	23.6
14	UTS614E - - P -	UTS614E - - S -	35.1	23.6

\* For shell size 18, please consult factory

Note : all dimensions are in mm

**UTS : Your first choice in waterproof connectors !**

# UTS screw termination contacts



**Description**

UTS series with screw termination contacts combines extreme sealing performance, rapid & secure connector mating with the ease of wire termination.

It requires no special skills or tools. Only a standard screwdriver is needed to fit the wires to the contacts, making it incredibly user-friendly and suitable for any field installation.

**Just fit the wires to the connector !**

**No special tools required !**

**Use a standard screwdriver !**

Stranded wire  
or  
Solide wire

**UTS : Your first choice in waterproof connectors !**



# UTS screw termination contacts

## Technical characteristics

### Mechanical

- Durability: 250 matings & unmatings
- Thermal shock: 5 cycles 30 min. from -40°C to 105°C per MIL-STD 1344 method 1003
- Screw tightening torque: 40 Ncm

### Electrical

- Current per contact max.: 13A
- Insulation resistance: ≥ 5000 MΩ
- Test potential: 2000 VAC
- Working voltage: up to 400V class III, PD 2 as per VDE up to 500V as per UL1977 see page 7 for more details
- Wire acceptance: 0.5mm<sup>2</sup> to 2.5mm<sup>2</sup>

### Environmental

- Operating temperature: -40°C to + 105°C
- Flammability rating: UL94-V0
- Sealing (mated): Dynamic IP68/IP69K
- UV resistant: No mechanical degradation or important variation of color after 5 years of exposure in natural environment (equivalence exposure to sun and moisture as per ISO4892)
- Salt spray: 500 hours

### Material

- Connectors + Backshells: Thermoplastic
- Contacts: High conductive copper alloy Min. 0.4µm gold plating
- RoHS compliant & conform to the Chinese standard SJ/T 1166-2006 (Chinese RoHS equivalent)

## Ordering information

Type	UTS	6	JC	12	4	P	SCR
<b>Connector type</b>							
1 In-line receptacle							
6 Cable plug							
7 Jam nut receptacle							
<b>Backshell</b>	JC: IP68/IP69K backshell (only plug + In-line connectors)						
<b>Shell size</b>	12 or 14						
<b>Number of contacts</b>	4 or 7						
<b>Type of contacts</b>	P: Pin contacts / S: Socket contacts						
<b>Contact termination</b>	SCR: Screw termination						

## UTS screw termination contact arrangements

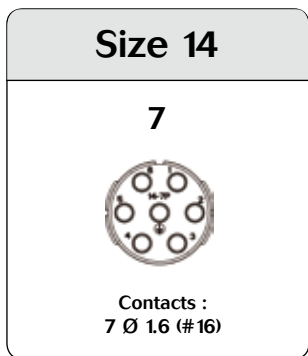
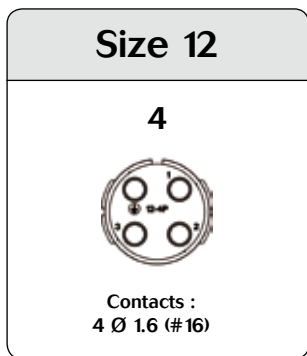

UTS : Your first choice in waterproof connectors !



# UTS screw termination contacts

## Connector accommodation



### UTS screw termination contact

UTS connector with screw termination contacts are fully intermateable and interchangeable with the UTS crimp and solder versions.

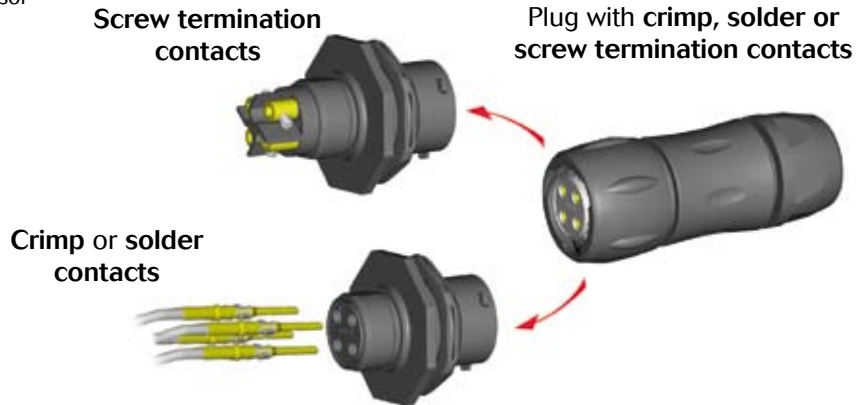

## Range presentation



### Jam nut receptacle

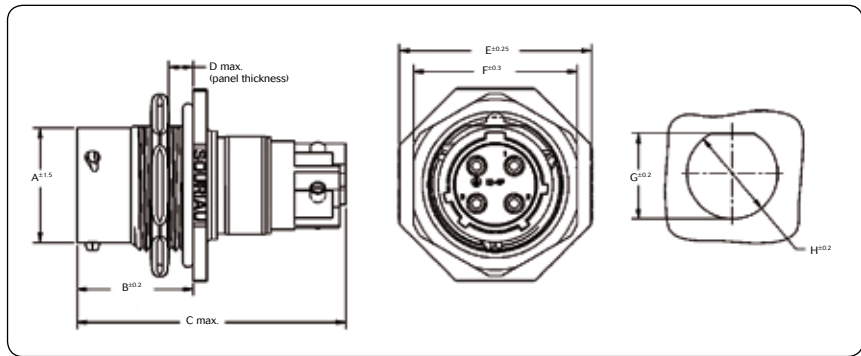

Shell size	Layout	Part numbers male contact	Part numbers female contact	A	B	C male	C female	D	E	F	G	H
12	12-4	UTS7124PSCR	UTS7124SSCR	19.0	19.3	46.5	38.3	3.2	31.8	27.0	21.2	22.5
14	14-7	UTS7147PSCR	UTS7147SSCR	22.2	19.3	52.5	44.4	3.2	34.9	30.2	24.3	25.7

Note : all dimensions are in mm

**UTS : Your first choice in waterproof connectors !**

# UTS screw termination contacts



## Cable plug

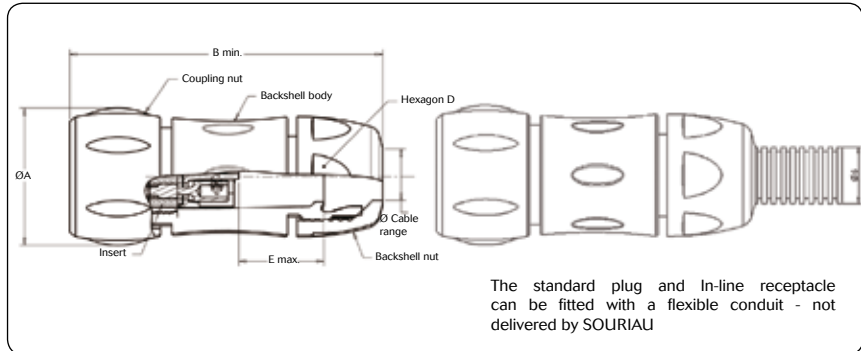

Shell size	Layout	Part numbers male contacts	Part numbers female contacts	Ø A	B	Ø Cable range Standard seal	Ø Cable range Reducing seal	Hexagon D	E (male)	E (female)
12	12-4	UTS6124PSCR	UTS6124SSCR	29.7	66.7	5.0 / 12.0	3.0 / 9.0	24.0	15.1	22.8
14	14-7	UTS6147PSCR	UTS6147SSCR	34.6	71.5	7.0 / 14.0	5.0 / 12.0	26.0	18.95	26.7

Coloured ring supplied as optional extra (see page 72).



## In-line receptacle

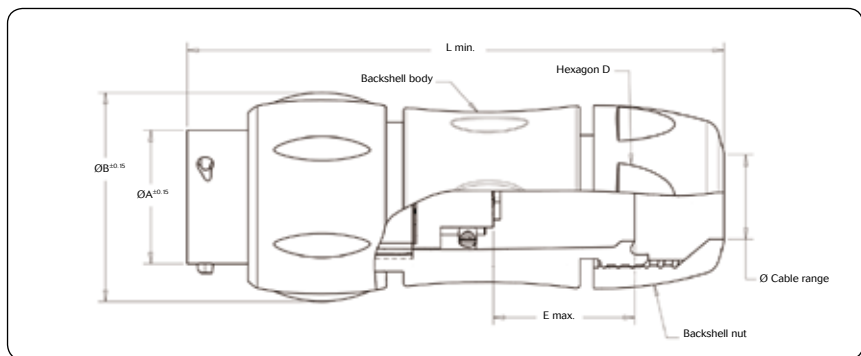

Shell size	Layout	Part numbers male contacts	Ø A	B	L	Ø Cable range Standard seal	Ø Cable range Reducing seal	Hexagon D	E
12	12-4	UTS1124PSCR	19.0	29.7	74.0	5.0 / 12.0	3.0 / 9.0	24.0	21.5
14	14-7	UTS1147PSCR	22.2	34.6	78.5	7.0 / 14.0	5.0 / 12.0	26.0	26.5

Coloured ring supplied as optional extra (see page 72).

Note : all dimensions are in mm

**UTS : Your first choice in waterproof connectors !**

# UTS RJ45

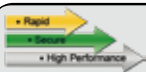

## Description

□ Intended for high speed Ethernet connection in severe environments, the plastic UTS connector with RJ45 cordset is a **universal solution**. Using any standard RJ45 cable, it needs NO tools for assembly or disassembly, making it easy to assemble and perfect for field installation.

□ The UTS RJ45 naturally benefits from the advantages of the UTS range:

**Dynamic IP68/69K** sealing performances

Rapid & secure locking system

High salt spray resistance

High vibration resistance

□ Available in shell size 18 - male RJ45 cordset in plug and female RJ45 cordset in receptacle, the UTS RJ45 can be used for Ethernet 10 BaseT, 100 BaseTX and 1000 BaseT, TIA/EIA 568B Cat5e and ISO/IEC 11801 class D networks.

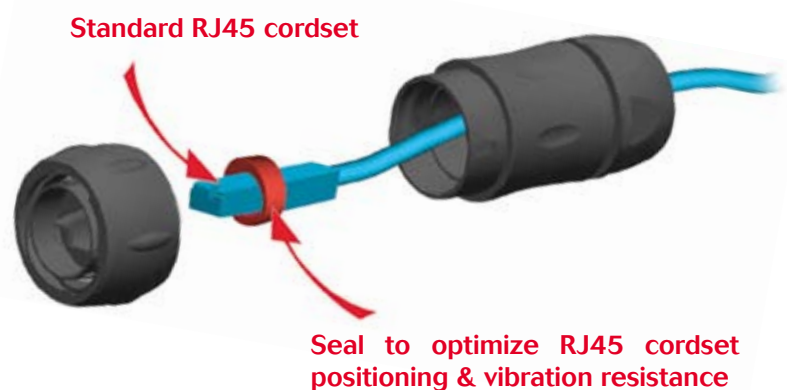

**UTS : Your first choice in waterproof connectors !**



# UTS RJ45

## Technical characteristics

### Mechanical

- Durability: 250 matings & unmatings

### Electrical

- Connection category: RJ45
- Cat5e per TIA/EIA 568C and class D per ISO/IEC 11801

### Environmental

- Operating temperature: -40°C to + 105°C
- Flammability rating: UL94-V0
- Sealing (mated): IP68/69K\*
- Salt spray: 500 hours

### Material

- Connectors + Backshells: Thermoplastic
- Nut: Metal
- RoHS compliant & conform to the Chinese standard SJ/T 1166-2006 (Chinese RoHS equivalent)

## Ordering information

Type		UTS	7	-	18	RJF	N	-
		UTS	6	JC	18	RJ	N	25
Body variation	6 Cable plug 7 Jam nut receptacle							
Backshell	JC = Easy handling plastic backshell (only for plug)							
Shell size	18							
Insert	RJF: Feed Through (only receptacle) / RJ: Free insert to accept any RJ45 (only plug)							
Polarisation	N : Normal / A, B: Different orientations							
Mandatory suffix	25 (only for plug)							

\* Short backshell on request

## UTS RJ45 contact arrangement

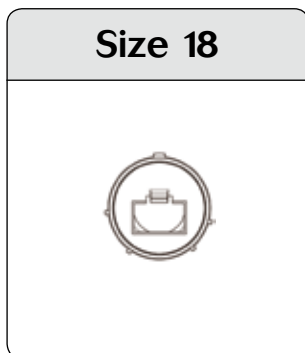

## Assembly instructions

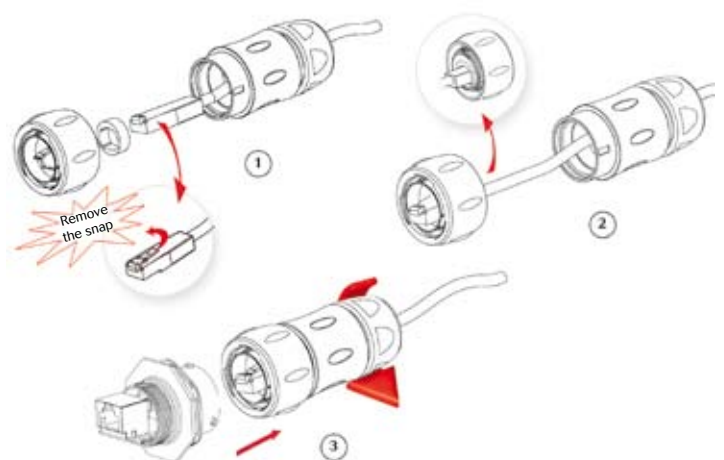

\* subject to a cylinder-shaped and non-convertible cordset

UTS : Your first choice in waterproof connectors !



# UTS RJ45

## Insert rotation

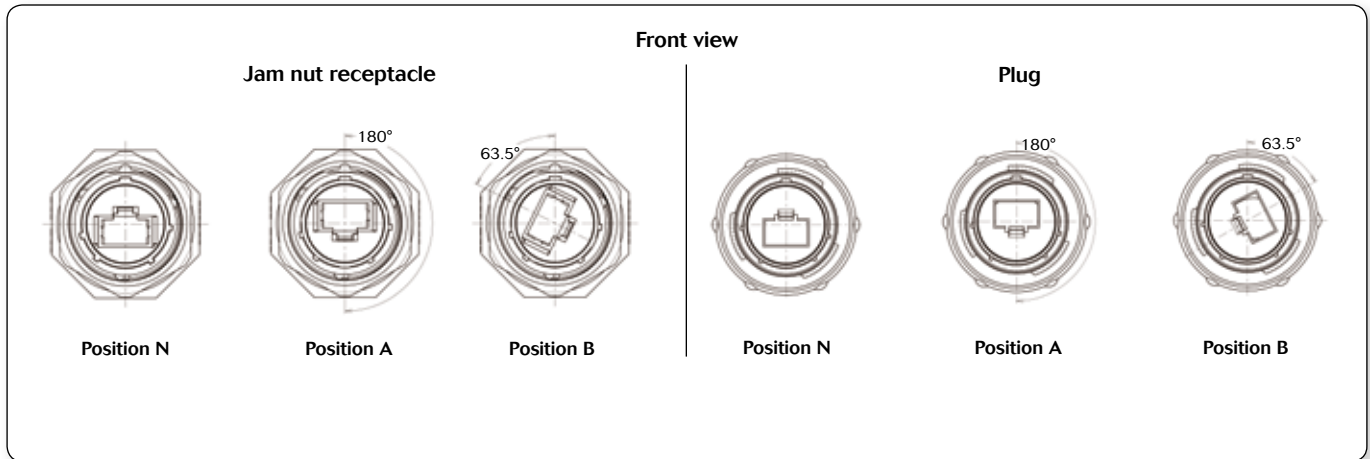

## Range presentation

→ Rapid  
→ Standard  
→ High Performance

### Cable plug



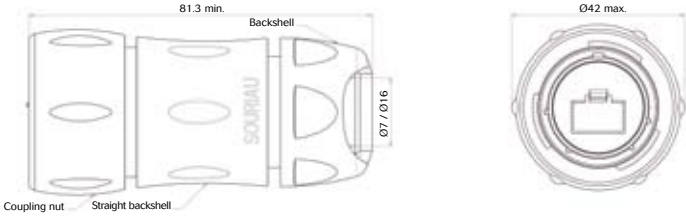

Part number: UTS6JC18RJN25

\* Add A or B between RJ & P, if different orientation / Coloured ring supplied as optional extra (see page 72).

→ Rapid  
→ Standard  
→ High Performance

### Jam nut receptacle



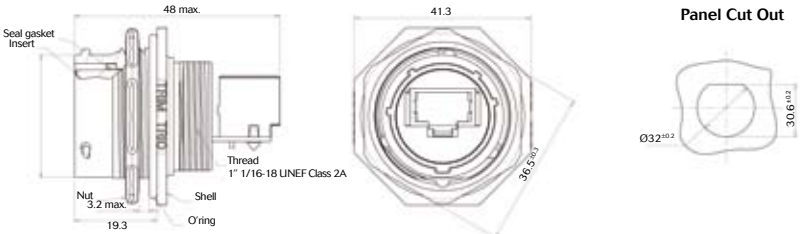

Part number: UTS718RJFN

\* Change N to A or B, if different orientation

Note : all dimensions are in mm

UTS : Your first choice in waterproof connectors !



# Accessories

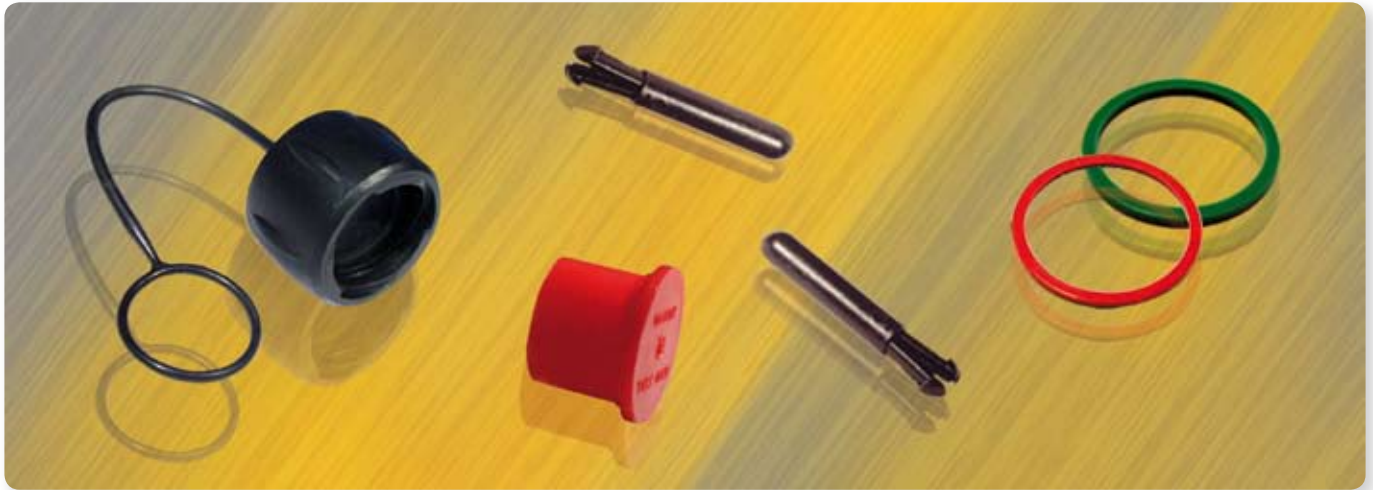

→ Rapid  
→ Secure  
→ High Performance

## Description

**Accessories for UTS series**

UTS series offers a wide range of accessories: from the plastic protective cap to the dust caps, coloured rings for visual identification or discrimination pins.

→ Rapid  
→ Secure  
→ High Performance

## Jam nut sealing caps



Part numbers	Shell size
UTS8DCG	8
UTS10DCG	10
UTS12DCG	12
UTS14DCG	14
UTS18DCG	18



Metal terminal\*

Part numbers	Shell size
UTS8DCGR	8
UTS10DCGR	10
UTS12DCGR	12
UTS14DCGR	14
UTS18DCGR	18

→ Rapid  
→ Secure  
→ High Performance

## Square flange sealing cap



Metal terminal\*

Part numbers	Shell size
UTS8DCGE	8
UTS10DCGE	10
UTS12DCGE	12
UTS14DCGE	14
UTS18DCGE	18

→ Rapid  
→ Secure  
→ High Performance

## Plug sealing cap\*\*



\*\* Except for UTS RJ45 plug

Part numbers	Shell size
UTS68DCG	8
UTS610DCG	10
UTS612DCG	12
UTS614DCG	14
UTS618DCG	18

\* Please consult factory

UTS : Your first choice in waterproof connectors !

# Accessories



**Colour coding rings**

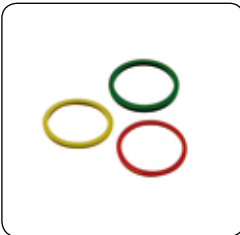

Part numbers		Shell size
Receptacles	Plugs	
LTS710CCR*	LTS610CCR*	10
LTS712CCR*	LTS612CCR*	12
LTS714CCR*	LTS614CCR*	14

\* Add G for Green, Y for Yellow, R for Red  
For shell sizes 8 & 18, please consult factory

**Gasket**



Part numbers / neoprene	Shell size
UTFD11B	8
UTFD12B	10
UTFD13B	12
UTFD14B	14
UTFD16B	18

**Plastic protective cap**



Part numbers		Shell size
Receptacle cap	Plug cap	
8500-5585A	8500-5594	8
8500-5586A	8500-5595	10
8500-5587A	8500-5596	12
8500-5588A	8500-5597	14
8500-5590A	8500-5599	18

**Bending protection spiral**



Please consult factory.

**Discrimination pin for size 16 cavities**



In applications where similar connectors are used next to each other, mismatching can be a reason for disturbances, system failure or even danger to operating personnel. To eliminate mismatching, all TRIM TRIO® connectors can be equipped with discrimination keys, which offer unlimited possibilities for a «fool-proof» interconnection system.

When one of these discrimination keys is used, the TRIM TRIO® connector will only mate with a connector which has a vacant contact or discrimination cavity at the corresponding position.

This system offers boundless opportunities for all applications which involve several identical TRIM TRIO® connectors.

**The material used is Thermoplastic.**

**SMSPKEO**  
A dummy contact, which can be inserted into an empty contact cavity in any of the TRIM TRIO® connectors.

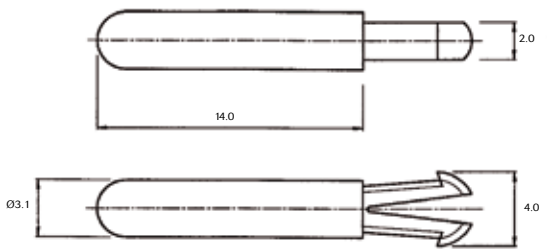

**UTS : Your first choice in waterproof connectors !**

# Tooling



## Description

### Crimptooling for TRIM TRIO® contacts

The TRIM TRIO® connection system not only offers versatility in connectors but production versatility in tooling as well. All information needed on tooling ranges from simple handtools for small production, over semi-automatic to full automatic strip-and-crimp machines can be found on the hereafter paragraphs.

All the TRIM TRIO® tooling and this for machined, stamped and formed and coax contacts is specially designed for this system to make reliable, trouble-free connections.

## Crimptooling for machined contacts

For an overview on crimping refer to «crimping tables» at the different contact sections.



Weight 400 gr  
Length 205 mm

### Y16RCM - for contacts #16

A lightweight, low cost crimping tool with fixed, 3-groove die set to crimp **size 16 TRIM TRIO® RM/RC loose piece machined contacts**.

The tool is ratcheted controlled to guarantee a complete crimp cycle. Each crimping tool is supplied with a locator to guarantee a perfect crimp indent positioning.



Weight 300 gr  
Length 170 mm

### MH860 - for contacts #16 & #20

A crimping tool qualified MIL-C-22520/7 that gives an 8 impression crimp with a precision cycle-controlled ratcheting mechanism. It features an 8 step crimp-depth selector knob and is designed to crimp **size 16 & size 20 TRIM TRIO® RM/RC machined contacts**. The tool can be provided with different locator heads to crimp different contacts types - locator to be ordered separately.

**UTS : Your first choice in waterproof connectors !**

# Tooling



## Crimptooling for stamped & formed contacts

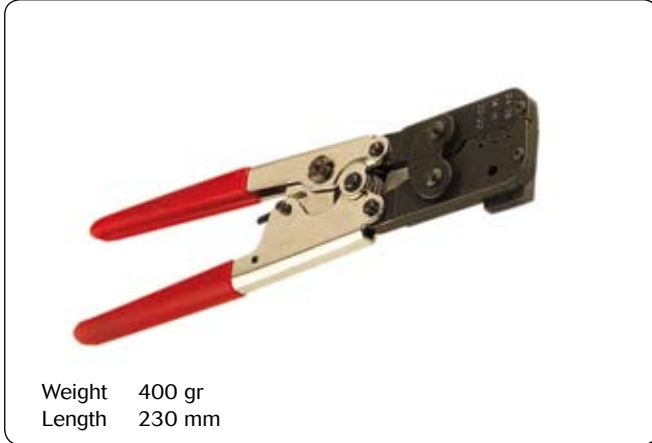

### Y14MTV - for contacts #16 & #20

A lightweight crimping tool with fixed 3-groove die set for AWG 26 to 14 for size 16 & size 20 TRIM TRIO® SM-M/SC-M stamped & formed contacts. Ratchet controlled to guarantee a complete crimp cycle.



### Y16SCM2 - for contacts #16

A lightweight crimping tool with fixed 3-groove die set for AWG 26 to 16 for size 16 TRIM TRIO® SM-M/SC-M loose piece formed contacts. Ratchet controlled to guarantee a complete crimp cycle. Each crimping tool is supplied with a locator to guarantee a perfect crimp indent positioning.

## Crimptooling for coaxial contacts

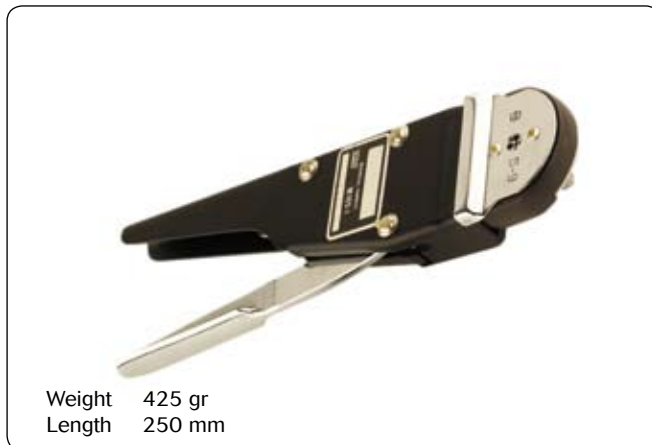

### M10S1 - for contacts #16

A robust, versatile, full cycling handtool which is fully qualified to the requirements of MIL-C-22520. Interchangeable 4-indent die sets are available for a wide range of coaxial contacts.

This tool is suitable for application of RMDX/RCDX coaxial contacts from the TRIM TRIO® range.



### AF8 - for coaxial contacts

Qualified MIL-C-22520/1, has virtually limitless application within the specified wire range of 12 through 26 AWG. It gives an 8 impression crimp with a precision cycle-controlled ratcheting mechanism and is used for certain coax contacts. The tool can be provided with different locators turret heads to crimp different contact types.

**UTS : Your first choice in waterproof connectors !**

# Tooling



## Crimptooling for power contacts

Size 12 (Ø 2.4mm)

Size 8 (Ø 3.6mm)



### Crimp tooling M317

Locator VGE1 0077A (#12) or VGE1 0078A (#8) - to be ordered separately

**UTS : Your first choice in waterproof connectors !**

# Tooling



## Automatic crimping tooling for size 16 contacts (Ø 1.6mm) & size 20 (Ø 1.0mm) contacts

### P107 Press - P/N P107

The P107 Crimping Press is available either in semi-automatic (for bench-top use) configuration or in full automatic (integrated into a cut and strip machine) configuration. The P107 has a standard stroke of 40 mm, and upon request a variable stroke version is available.

The standard crimping height (measured from the applicator base plate to the press T-coupling when at Bottom Dead Center) is 135.8mm ± 0.02 mm, but different kits to adapt it to different-size applicators are available upon request. The JOG option allows the operator to manually step-by-step cycle the press. The semi-automatic configuration (for bench top use) always includes safety cover, reel arm, foot switch according to the international safety standard and CE regulation. Produced under a quality Management System certified to ISO 9001 (TÜV).

Power	0.75 Kw	Weight	85 Kg
Force	2000 Kg	Dimensions	310x770x310
Stroke	40 mm	Crimping height	135.8 mm



### MLS--- - left side miniapplicator

Miniapplicator to crimp machined or stamped and formed TRIM TRIO® contacts.

All the adjustments requested to make tool correctly functioning (crimp feeding pitch, crimp height ...) can be simply made. Resolution of 0.03 mm. Regulation range from 0 to 2.7 mm.

Ref	See contact sections
Stroke	40 mm
Weight	4.5 kg
Dimensions	145x107x150



### SC11 Stripper-crimper - P/N SC11

The SC11 Stripper-Crimper is a wire-stripping unit conceived to be integrated with a crimping station (press and applicator). In one smooth movement, the SC11 grabs the wire, strips it and moves it over to the applicator's anvil, where it will be crimped to the terminal. PLC controlled, the electro - pneumatic actuating system grants ease of installation, use and maintenance. It can be cycled either by pedal or by a sensor that detects the presence of the wire to be stripped. Either way, the stripped wire will be automatically moved over to the applicator and crimped to the terminal. The SC11 can be used with multiple-core wires. Produced under a quality Management System certified to ISO 9001 (TÜV).

Pressure	5 - 7 bars	Stripping length	2 - 12mm
Cable section	0.2 - 3 mm <sup>2</sup>	Weight	5.1 kg

### Options

#### 1 - Quality assurance for crimping technology

A crimping force sensor continuously checks the quality of each individual crimp and records it without impairing the processing speed. The sensor detects bad crimp connections, eliminating the high subsequent costs otherwise caused by them.

For ordering, consult factory.

#### 2 - Crimp pull press gauge

The crimp pull press gauge allows to measure the resistance to the pulling of crimped terminals.

#### 3 - Crimp height measuring device

#### 4 - Kit press lighting lamp

For ordering, consult factory.

**UTS : Your first choice in waterproof connectors !**

# Tooling



## Extraction tooling for size 16 contacts (Ø1.6mm)

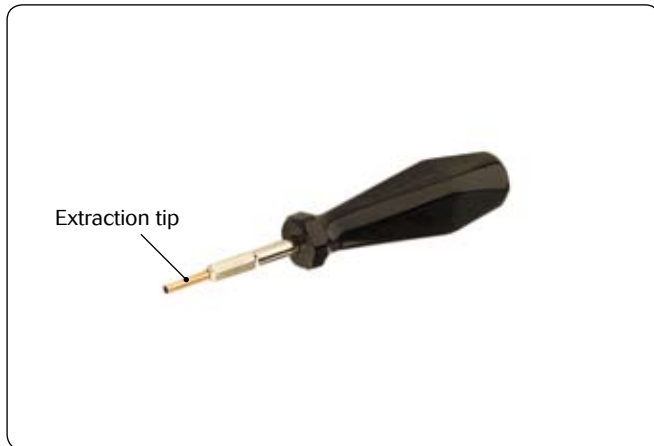

### RX2025GE1

A spring loaded extraction tool for the full range of TRIM TRIO® contacts. This tool ensures that the contact locking louvres are fully retracted before any pressure is applied to extract a contact. Part number for extraction tip: RX2025GE1P4

## Extraction tooling for size 20 contacts (Ø1.0 mm)



### RX20D44

A spring loaded extraction tool. This tool ensures that the contact locking louvres are fully retracted before any pressure is applied to extract contact. It is especially suitable for applications where the integrity of the assemblies are of the utmost importance.

## Contact extraction for size 16 & size 20 contacts

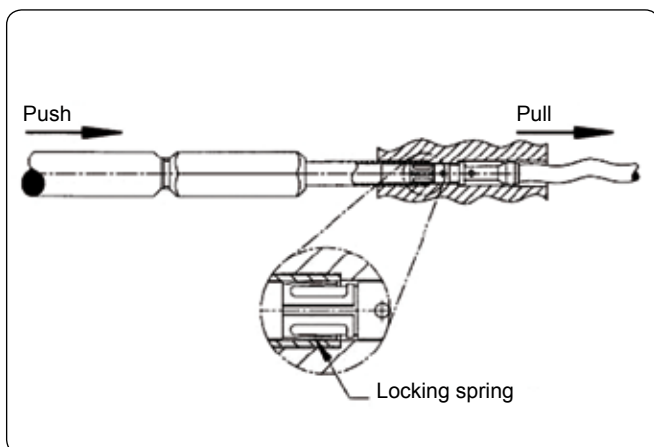

### How to extract a contact out of its cavity?

Slide the extraction tip over contact from mating side till the locking spring from the contact is depressed.

Push on handle to push out the contact with the spring loaded inner plunger.

**UTS : Your first choice in waterproof connectors !**

# Tooling



## Insertion tooling for Size 16 (Ø1.6 mm) Size 20 contacts (Ø1.0 mm)



### RTM205

This tool is especially designed to ease insertion of any TRIM TRIO® contact crimped on very flexible or small wire sizes. Simply position the insertion tool so that the tip of the tool bears against the back of the wire barrel, retaining the wire with thumb in the groove of the tool. Push the contact slowly into the connector until it snaps into position.

## Extraction tooling for power contacts size 12 (Ø2.4 mm) & size 8 (Ø3.6 mm)

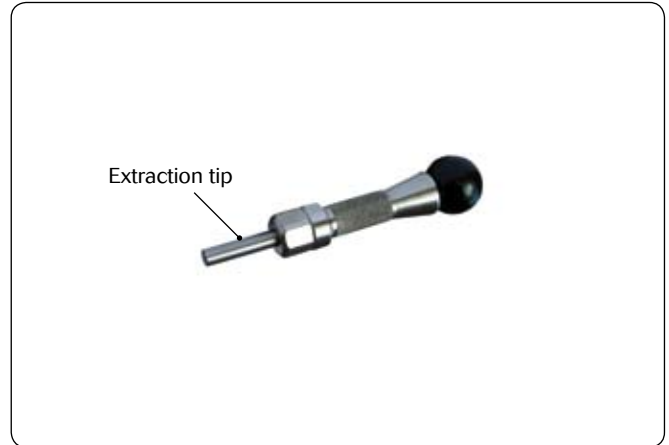

### Extraction tooling 5106.02.109.24\* (#12)

Extraction tip: 5106.021.34.24 - if ordered separately

### Extraction tooling 5106.02.109.36\* (#8)

Extraction tip: 5106.021.34.36 - if ordered separately

*\* Part number includes both extraction tool + extraction tip*

**UTS : Your first choice in waterproof connectors !**



# UTS series



## What is IP rating & how it is specified ?

- The connector's housing, sealing and locking mechanism protect the connection from external influences such as mechanical shocks, foreign bodies, humidity, dust, water and other fluids.
- The degree of protection is explained in IEC 60529, DIN EN60529 (DIN 40050) standards that categorize connections according to foreign body and water protection.
- The degree of protection is indicated by IP (International Protection) followed by 2 digits (see example below):

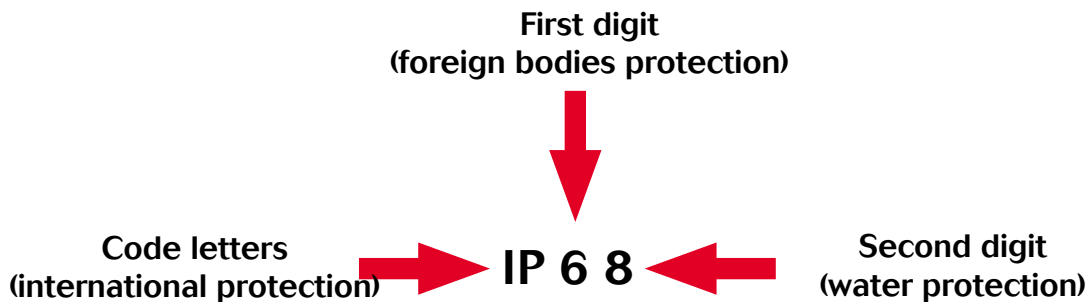

First digit	Degree of protection	Second digit	Degree of protection
0	No protection against accidental contact. No protection against solid foreign bodies.	0	No protection against water.
1	Protection against contacts with any large area by hand and against large solid foreign bodies with a diameter bigger than 50 mm.	1	Drip-proof. Protection against vertical water drips.
2	Protection against contacts with the fingers. Protection against solid foreign bodies with a diameter bigger than 12 mm.	2	Drip-proof. Protection against water drips up to a 15° angle.
3	Protection against tools, wires or similar objects with a diameter bigger than 2.5 mm. Protection against small solid bodies with a diameter bigger than 2.5 mm.	3	Spray-proof. Protection against diagonal water drips up to a 60° angle.
4	As 3 however diameter is bigger than 1 mm.	4	Splash-proof. Protection against splashed water from all directions.
5	Full protection against contacts. Protection against interior injurious dust deposits.	5	Hise-proof. Protection against water (out of a nozzle) from all directions.
6	Total protection against contacts. Protection against penetration of dust.	6	Protection against temporary flooding.
		7	Protection against temporary immersions.
		8	Protection against water pressure. Pressure to be specified by supplier.
		9K	High pressure hose-proof. Protection against high pressure water (out of a nozzle) from all directions.

UTS offers high sealing performance IP68 / 69K... Even in dynamic situations.

**UTS : Your first choice in waterproof connectors !**



# UTS series



## What is NEMA ?

- **NEMA definition**

The National Electrical Manufacturer Association or **NEMA** relates to standards for electrical enclosures. It defines the types of environments in which these enclosures can be used.

- **NEMA ratings vs IP ratings**

Whereas IP ratings only consider protection against ingress of foreign bodies - first digit - and ingress of water (second digit), **NEMA** ratings consider these but also verify protection from external ice, corrosive materials, oil immersion, etc.

The correlation between NEMA & IP being limited only to dust and water, we can state that a NEMA type is *equivalent to* an IP rating but it is not possible to say the contrary.

Below a list of some NEMA standards:

Enclosure rating	IP20	IP22	IP55	IP64	IP65	IP66	IP67
Type 1	•						
Type 3				•			
Type 3R		•					
Type 3S				•			
Type 4						•	
Type 4X						•	
Type 6							•
Type 12			•				
Type 13					•		

- indicates compliance

Type 6 rating can be either Type 6 or Type 6P - please see below:

6	IP67	Enclosures constructed for either indoor or outdoor use to provide a degree of protection to personnel against incidental contact with the enclosed equipment, falling dirt, hose-directed water, the entry of water during occasional temporary submersion at a limited depth and damage from external ice formation.
6P	IP67	Enclosures constructed for either indoor or outdoor use to provide a degree of protection to personnel against incidental contact with the enclosed equipment, falling dirt, hose-directed water, the entry of water during prolonged submersion at a limited depth and damage from external ice formation.

**UTS : Your first choice in waterproof connectors !**



# UTS series

Suitable for a broad range of applications

Its uses are endless!  
here are a few...

Off Road



Instrumentation/Measurement



Machine Tools/Special Machines



Medical



Robotics



Railway & Mass Transit



and there is more...:

- Renewable Energy,
- Portable Energy,
- Factory Automation & Control,
- Building Automation & Control,
- Telecom/Datacom Infrastructure,
- Geophysics & Oceanography,
- Mining,
- etc...

**UTS : Your first choice in waterproof connectors !**





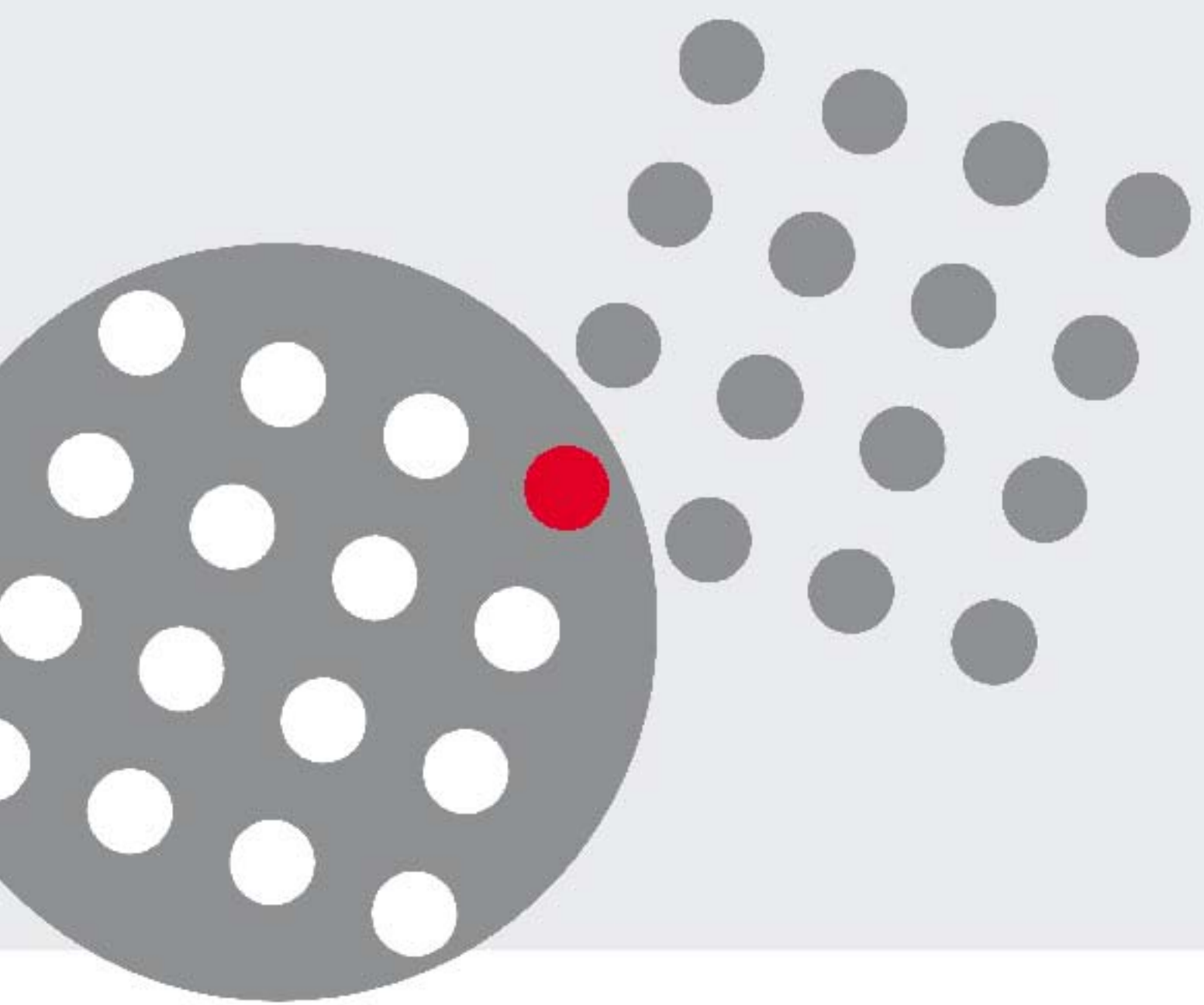

[www.souriau.com](http://www.souriau.com)  
[contactindustry@souriau.com](mailto:contactindustry@souriau.com)

