

Nov.1.2017 Copyright 2017 HIROSE ELECTRIC CO., LTD. All Rights Reserved.

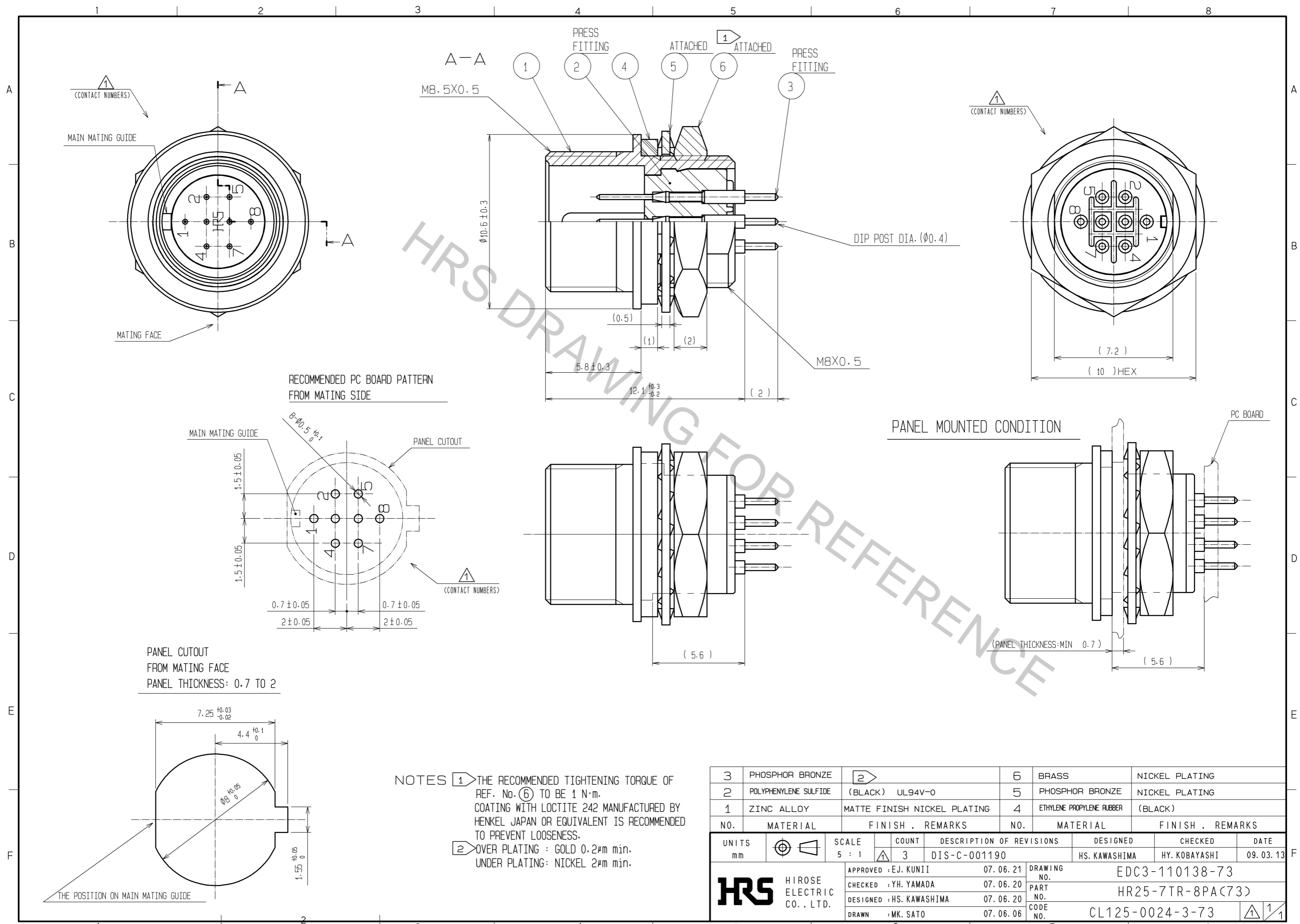

NOTES ① THE RECOMMENDED TIGHTENING TORQUE OF REF. No. ⑥ TO BE 1 N·m.  
 COATING WITH LOCTITE 242 MANUFACTURED BY HENKEL JAPAN OR EQUIVALENT IS RECOMMENDED TO PREVENT LOOSENESS.  
 ② OVER PLATING : GOLD 0.2μm min.  
 UNDER PLATING: NICKEL 2μm min.

3	PHOSPHOR BRONZE	②	6	BRASS	NICKEL PLATING
2	POLYPHENYLENE SULFIDE	(BLACK) UL94V-0	5	PHOSPHOR BRONZE	NICKEL PLATING
1	ZINC ALLOY	MATTE FINISH NICKEL PLATING	4	ETHYLENE PROPYLENE RUBBER	(BLACK)
NO.	MATERIAL	FINISH . REMARKS	NO.	MATERIAL	FINISH . REMARKS
UNITS	mm	SCALE	5 : 1	COUNT	3
		DESCRIPTION OF REVISIONS	DESIGNED	CHECKED	DATE
		DIS-C-001190	HS. KAWASHIMA	HY. KOBAYASHI	09.03.13
APPROVED : EJ. KUNII 07.06.21			DRAWING NO. EDC3-110138-73		
CHECKED : YH. YAMADA 07.06.20			PART NO. HR25-7TR-8PA(73)		
DESIGNED : HS. KAWASHIMA 07.06.20			CODE NO. CL125-0024-3-73		
DRAWN : MK. SATO 07.06.06			①/①		