



Contactor relay, 2N/O+2N/C, AC

Part no. DILA-22(230V50HZ,240V60HZ)
Catalog No. 276399
Eaton Catalog No. XTRE10B22F
EL-Nummer (Norway) 4130208

Delivery program

| | | | | |
|---|-------|---|--|---|
| Product range | | | | DILA relays |
| Application | | | | Contactor relays |
| Description | | | | Basic devices with positive operation contacts |
| Connection technique | | | | Screw terminals |
| Rated operational current | | | | |
| AC-15 | | | | |
| 220 V 230 V 240 V | I_e | A | | 4 |
| 380 V 400 V 415 V | I_e | A | | 4 |
| Contacts | | | | |
| N/O = Normally open | | | | 2 N/O |
| N/C = Normally closed | | | | 2 NC |
| Contact sequence | | | | |
| Code number and version of combination | | | | |
| Distinctive number | | | | 22E |
| Can be combined with auxiliary contact module | | | | DILA-XHI(V)... |
| Actuating voltage | | | | 230 V 50 Hz, 240 V 60 Hz |
| Voltage AC/DC | | | | AC operation |
| Instructions | | | | Contact numbers to EN 50011 Coil terminal markings to EN 50005 |

Technical data

| | | | | |
|---|--------------|---------------|--|--|
| General | | | | |
| Standards | | | | IEC/EN 60947, EN 60947-5-1, VDE 0660, UL, CSA |
| Lifespan, mechanical | | | | |
| AC operated | Operations | $\times 10^6$ | | 20 |
| Maximum operating frequency | Operations/h | | | 9000 |
| Climatic proofing | | | | Damp heat, constant, to IEC 60068-2-78 Damp heat, cyclic, to IEC 60068-2-30 |
| Ambient temperature | | | | |
| Open | | °C | | -25 - +60 |
| Enclosed | | °C | | -25 - 40 |
| Ambient temperature, storage | | °C | | -40 - 80 |
| Mounting position | | | | |
| Mounting position | | | | |
| Mechanical shock resistance (IEC/EN 60068-2-27) | | | | |
| Half-sinusoidal shock, 10 ms | | | | |
| Basic unit with auxiliary contact module | | g | | |
| N/O contact | | g | | 7 |
| N/C contact | | g | | 5 |
| Degree of Protection | | | | IP20 |

| | | | |
|---|--|-----------------|--------------------------------------|
| Protection against direct contact when actuated from front (EN 50274) | | | Finger and back-of-hand proof |
| Weight | | | |
| AC operated | | kg | 0.24 |
| Terminal capacities | | mm ² | |
| Screw terminals | | | |
| Solid | | mm ² | 1 x (0,75 - 4) 2 x (0,75 - 2,5) |
| Flexible with ferrule | | mm ² | 1 x (0,75 - 2,5) 2 x (0,75 - 2,5) |
| Solid or stranded | | AWG | 18 - 14 |
| Stripping length | | mm | 10 |
| Terminal screw | | | M3.5 |
| Pozidriv screwdriver | | Size | 2 |
| Standard screwdriver | | mm | 0.8 x 5.5 1 x 6 |
| Max. tightening torque | | Nm | 1.2 |
| Spring-loaded terminals | | | |
| Stripping length | | mm | 10 |

Contacts

| | | | |
|---|----------------|-----------|--|
| Positive operating contacts to ZH 1/457, including auxiliary contact module | | | Yes |
| Rated impulse withstand voltage | U_{imp} | V AC | 6000 |
| Overvoltage category/pollution degree | | | III/3 |
| Rated insulation voltage | U_i | V AC | 690 |
| Rated operational voltage | U_e | V AC | 690 |
| Safe isolation to EN 61140 | | | |
| between coil and auxiliary contacts | | V AC | 400 |
| between the auxiliary contacts | | V AC | 400 |
| Rated operational current | | A | |
| Conventional free air thermal current, 1 pole | | | |
| Open | | | |
| at 60 °C | $I_{th} = I_e$ | A | 16 |
| AC-15 | | | |
| 220 V 230 V 240 V | I_e | A | 4 |
| 380 V 400 V 415 V | I_e | A | 4 |
| 500 V | I_e | A | 1.5 |
| DC current | | | |
| Notes | | | Switch-on and switch-off conditions based on DC-13, time constant as specified. |
| DC L/R \leq 15 ms | | | |
| Contacts in series: | | A | |
| 1 | 24 V | A | 10 |
| 1 | 60 V | A | 6 |
| 2 | 60 V | A | 10 |
| 1 | 110 V | A | 3 |
| 3 | 110 V | A | 6 |
| 1 | 220 V | A | 1 |
| 3 | 220 V | A | 5 |
| DC L/R \leq 50 ms | | | |
| Contacts in series: | | A | |
| 3 | 24 V | A | 4 |
| 3 | 60 V | A | 4 |
| 3 | 110 V | A | 2 |
| 3 | 220 V | A | 1 |
| Control circuit reliability | Failure rate | λ | $<10^{-8}$, < one failure at 100 million operations (at $U_e = 24$ V DC, $U_{min} = 17$ V, $I_{min} = 5.4$ mA) |
| Short-circuit rating without welding | | | |
| Maximum overcurrent protective device | | | |

| | | |
|---------------------------------------|---------|------|
| 220 V 230 V 240 V | PKZM0 | 4 |
| 380 V 400 V 415 V | PKZM0 | 4 |
| Short-circuit protection maximum fuse | | |
| 500 V | A gG/gL | 10 |
| Current heat loss at I_{th} | | |
| AC operated | W | 0.53 |

Magnet systems

| | | | |
|--|---------|---------|---------|
| Voltage tolerance | | | |
| AC operated | | | |
| Single-voltage coil 50 Hz and dual-voltage coil 50 Hz, 60 Hz | Pick-up | $x U_c$ | |
| Voltage tolerance Single-voltage coil 50 Hz and dual-voltage coil 50 Hz, 60 Hz Pick-up voltage, min. | | $x U_c$ | 0.8 |
| Voltage tolerance Single-voltage coil 50 Hz and dual-voltage coil 50 Hz, 60 Hz Pick-up voltage, max. | | $x U_c$ | 1.1 |
| Power consumption | | | |
| AC operation | | | |
| Single-voltage coil 50 Hz and dual-voltage coil 50 Hz, 60 Hz | Pick-up | VA | 24 |
| Single-voltage coil 50 Hz and dual-voltage coil 50 Hz, 60 Hz | Sealing | VA | 3.4 |
| Single-voltage coil 50 Hz and dual-voltage coil 50 Hz, 60 Hz | Sealing | W | 1.4 |
| duty factor | | % DF | 100 |
| Changeover time at 100 % U_S (recommended value) | | | |
| AC operated closing delay | | ms | 15 - 21 |
| AC operated N/O contact opening delay | | ms | 9 - 18 |

Rating data for approved types

| | | | |
|--------------------|--|---|------|
| Auxiliary contacts | | | |
| Pilot Duty | | | |
| AC operated | | | A600 |
| DC operated | | | P300 |
| General Use | | | |
| AC | | V | 600 |
| AC | | A | 15 |
| DC | | V | 250 |
| DC | | A | 1 |

Design verification as per IEC/EN 61439

| | | | |
|--|------------|----|--|
| Technical data for design verification | | | |
| Rated operational current for specified heat dissipation | I_n | A | 15.5 |
| Heat dissipation per pole, current-dependent | P_{vid} | W | 0.5 |
| Equipment heat dissipation, current-dependent | P_{vid} | W | 0 |
| Static heat dissipation, non-current-dependent | P_{vs} | W | 1.4 |
| Heat dissipation capacity | P_{diss} | W | 0 |
| Operating ambient temperature max. | | °C | -25 |
| Operating ambient temperature max. | | °C | 60 |
| IEC/EN 61439 design verification | | | |
| 10.2 Strength of materials and parts | | | |
| 10.2.2 Corrosion resistance | | | Meets the product standard's requirements. |
| 10.2.3.1 Verification of thermal stability of enclosures | | | Meets the product standard's requirements. |
| 10.2.3.2 Verification of resistance of insulating materials to normal heat | | | Meets the product standard's requirements. |
| 10.2.3.3 Verification of resistance of insulating materials to abnormal heat and fire due to internal electric effects | | | Meets the product standard's requirements. |
| 10.2.4 Resistance to ultra-violet (UV) radiation | | | Meets the product standard's requirements. |
| 10.2.5 Lifting | | | Does not apply, since the entire switchgear needs to be evaluated. |
| 10.2.6 Mechanical impact | | | Does not apply, since the entire switchgear needs to be evaluated. |
| 10.2.7 Inscriptions | | | Meets the product standard's requirements. |
| 10.3 Degree of protection of ASSEMBLIES | | | Does not apply, since the entire switchgear needs to be evaluated. |
| 10.4 Clearances and creepage distances | | | Meets the product standard's requirements. |

| | | |
|--|--|--|
| 10.5 Protection against electric shock | | Does not apply, since the entire switchgear needs to be evaluated. |
| 10.6 Incorporation of switching devices and components | | Does not apply, since the entire switchgear needs to be evaluated. |
| 10.7 Internal electrical circuits and connections | | Is the panel builder's responsibility. |
| 10.8 Connections for external conductors | | Is the panel builder's responsibility. |
| 10.9 Insulation properties | | |
| 10.9.2 Power-frequency electric strength | | Is the panel builder's responsibility. |
| 10.9.3 Impulse withstand voltage | | Is the panel builder's responsibility. |
| 10.9.4 Testing of enclosures made of insulating material | | Is the panel builder's responsibility. |
| 10.10 Temperature rise | | The panel builder is responsible for the temperature rise calculation. Eaton will provide heat dissipation data for the devices. |
| 10.11 Short-circuit rating | | Is the panel builder's responsibility. The specifications for the switchgear must be observed. |
| 10.12 Electromagnetic compatibility | | Is the panel builder's responsibility. The specifications for the switchgear must be observed. |
| 10.13 Mechanical function | | The device meets the requirements, provided the information in the instruction leaflet (IL) is observed. |

Technical data ETIM 6.0

| | | |
|--|---|------------------|
| Low-voltage industrial components (EG000017) / Contactor relay (EC000196) | | |
| Electric engineering, automation, process control engineering / Low-voltage switch technology / Contactor (LV) / Contactor relay (ecl@ss8.1-27-37-10-01 [AAB716011]) | | |
| Rated control supply voltage Us at AC 50HZ | V | 230 - 230 |
| Rated control supply voltage Us at AC 60HZ | V | 240 - 240 |
| Rated control supply voltage Us at DC | V | 0 - 0 |
| Voltage type for actuating | | AC |
| Rated operation current Ie , 400 V | A | 4 |
| Connection type auxiliary circuit | | Screw connection |
| Mounting method | | DIN-rail/screw |
| Interface | | No |
| Number of auxiliary contacts as normally closed contact | | 2 |
| Number of auxiliary contacts as normally open contact | | 2 |
| Number of auxiliary contacts as normally closed contact, delayed switching | | 0 |
| Number of auxiliary contacts as normally open contact, leading | | 0 |
| With LED indication | | No |
| Number of auxiliary contacts as change-over contact | | 0 |
| Manual operation possible | | No |

Approvals

| | | |
|--------------------------------------|--|--|
| Product Standards | | IEC/EN 60947-4-1; UL 60947-4-1; CSA - C22.2 No. 60947-4-1-14; CE marking |
| UL File No. | | E29184 |
| UL Category Control No. | | NKCR |
| CSA File No. | | 012528 |
| CSA Class No. | | 3211-03 |
| North America Certification | | UL listed, CSA certified |
| Specially designed for North America | | No |

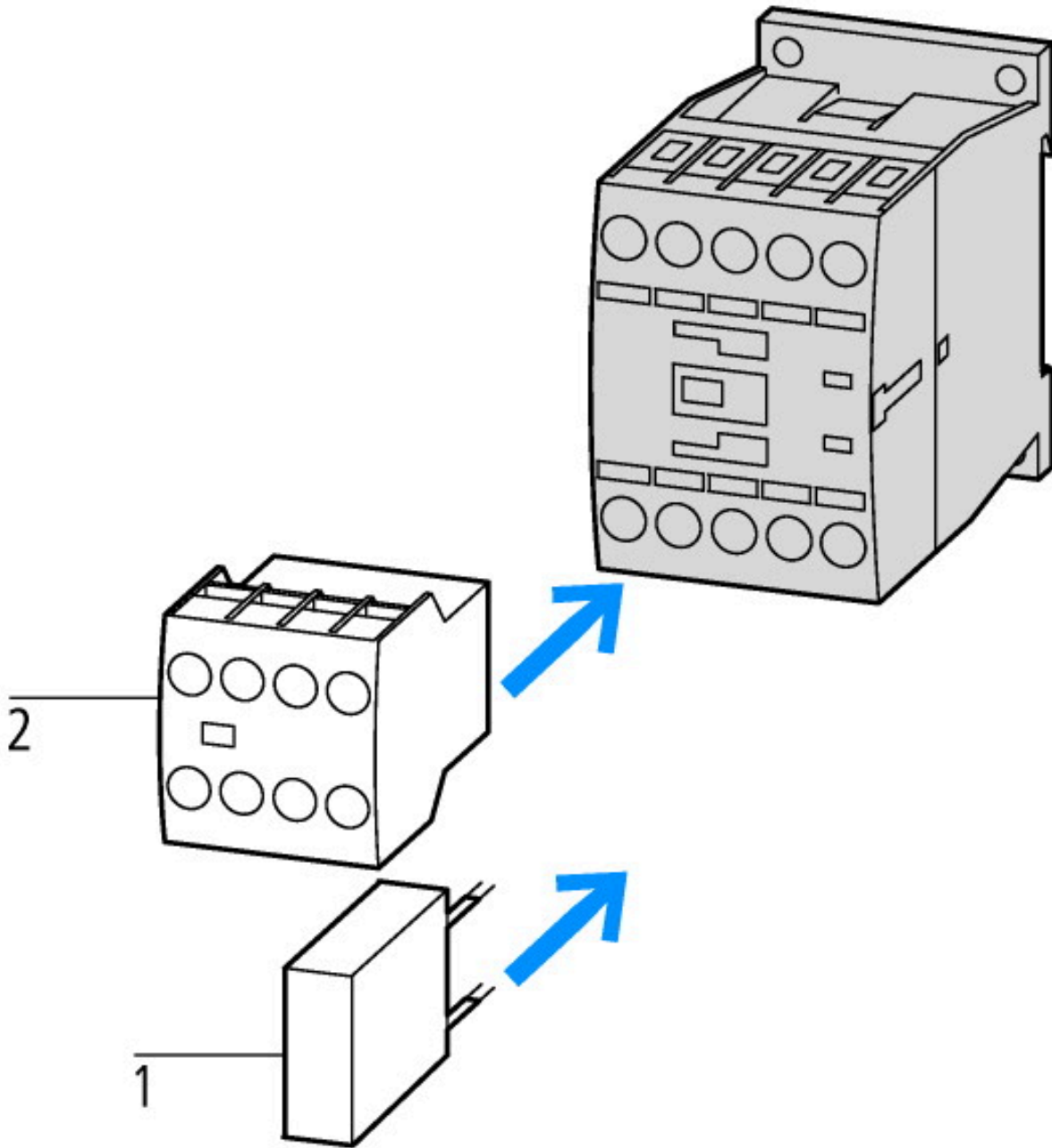

1: Suppressor
2: Auxiliary contact module



Component lifespan (operations)
 I_e = Rated operational current

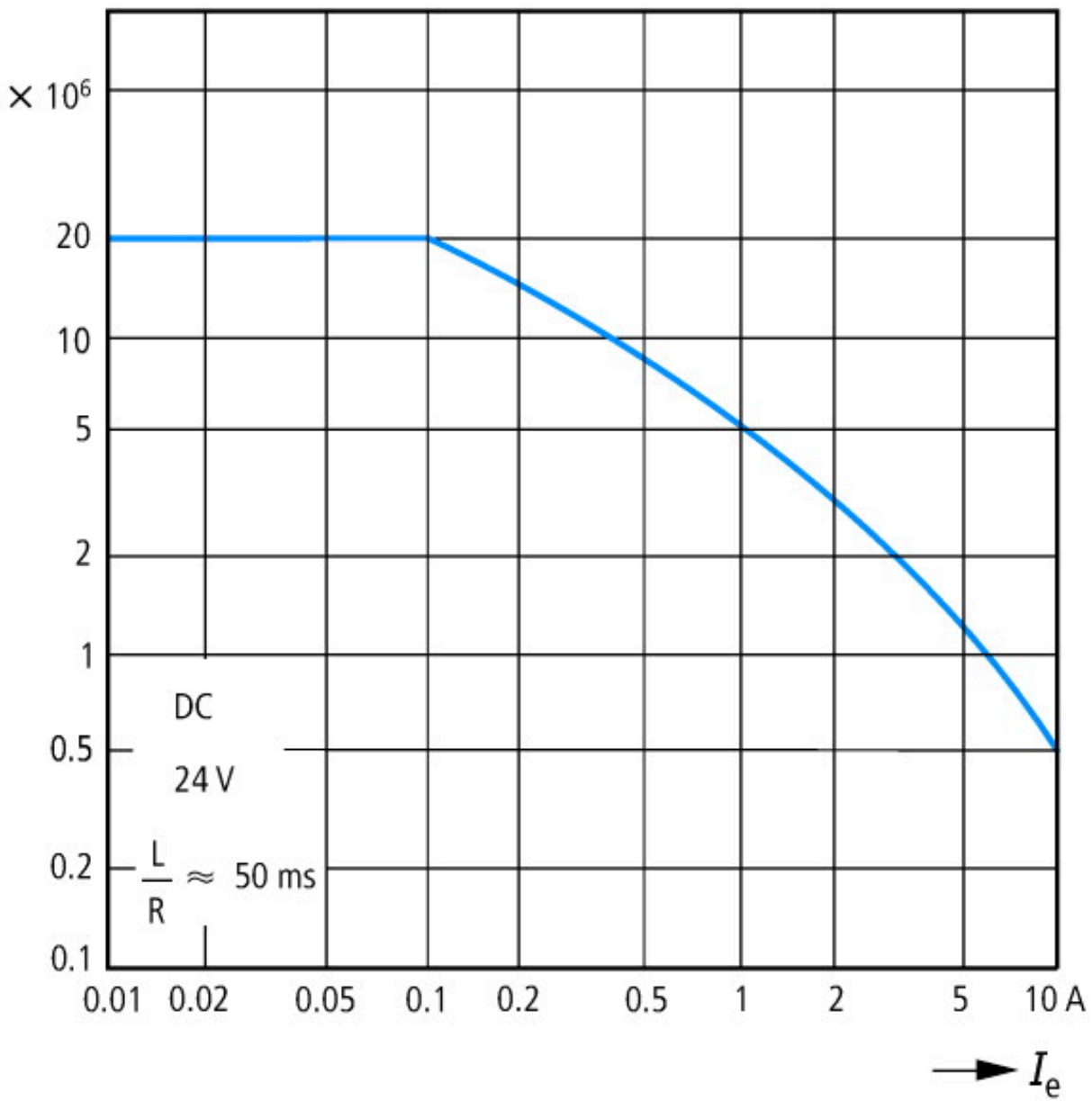

Component lifespan (operations)
 I_e = Rated operational current

Dimensions

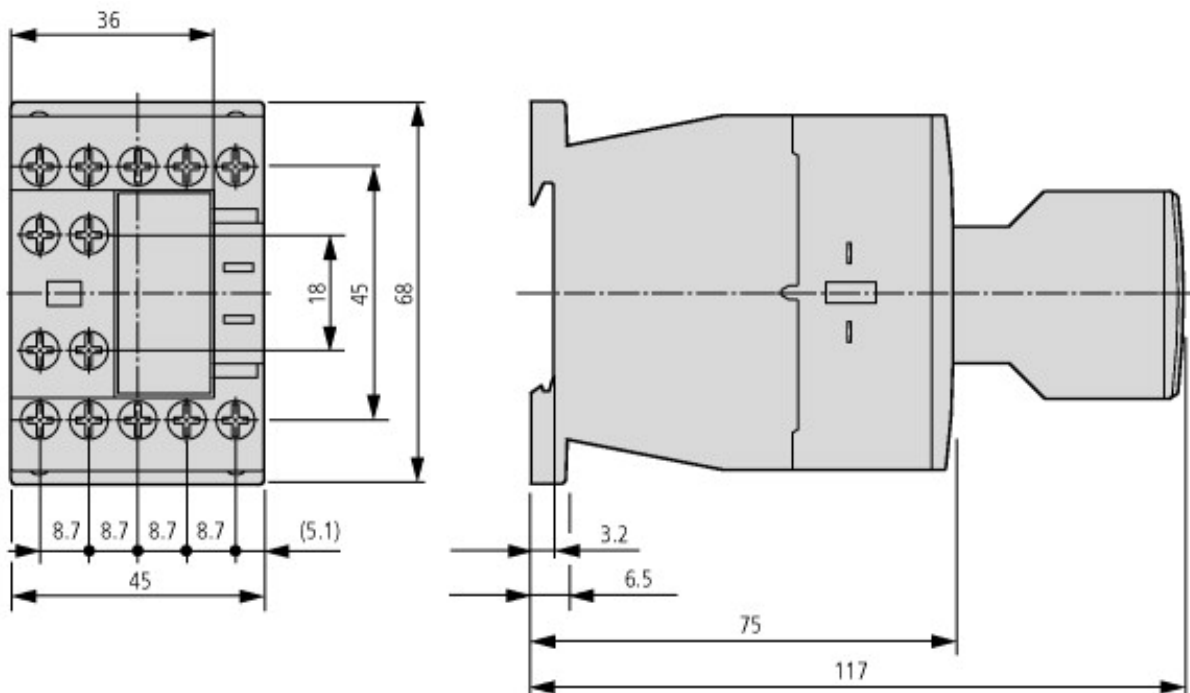

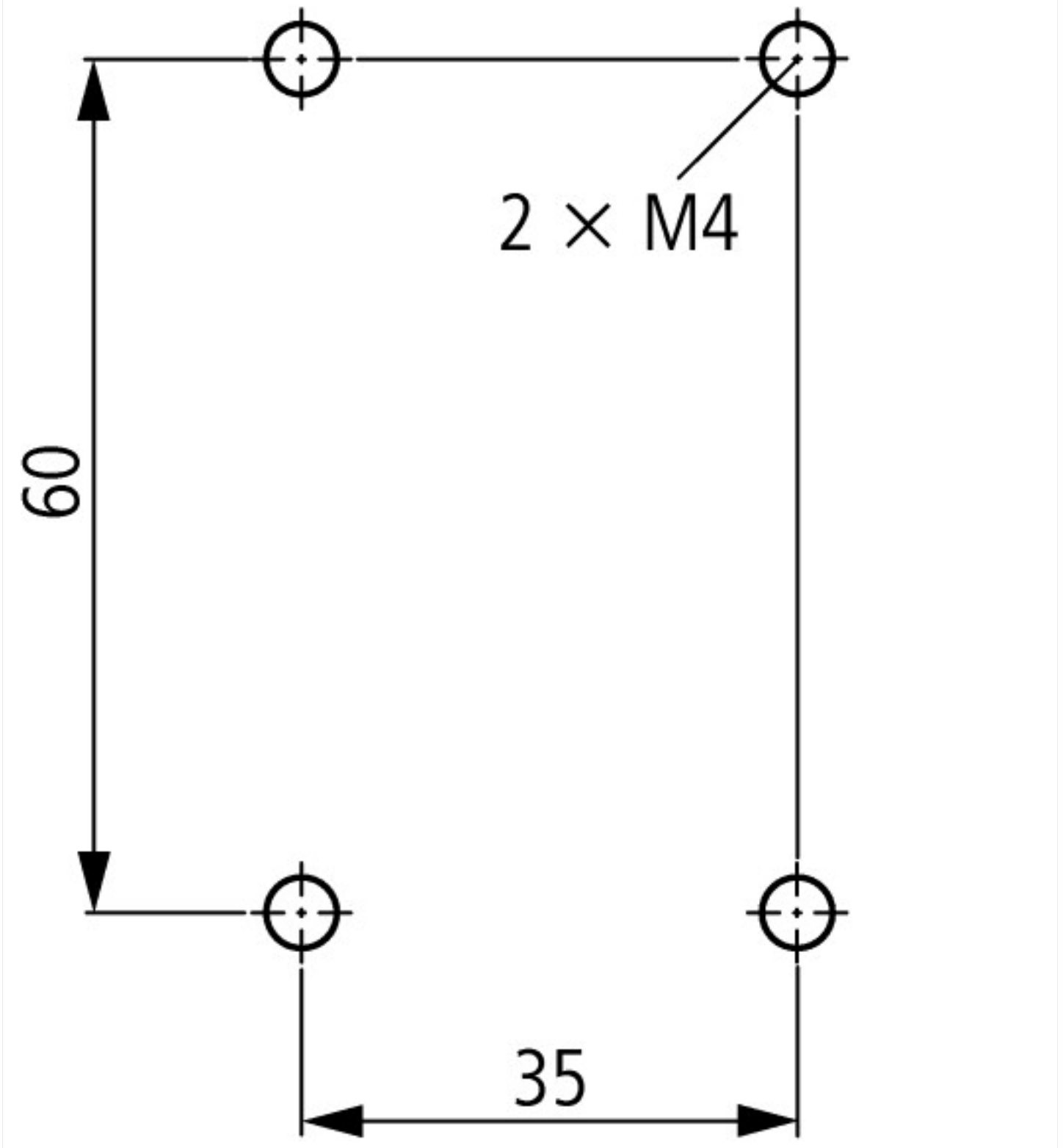

Assets (Links)

Declaration of Conformity

00002560

Instruction Leaflets

IL03407013Z2012_03

Additional product information (links)

IL03407013Z (AWA2100-2126) Contactors

IL03407013Z (AWA2100-2126) Contactors ftp://ftp.moeller.net/DOCUMENTATION/AWA_INSTRUCTIONS/IL03407013Z2012_03.pdf

UL/CSA: Approved rating data <http://de.ecat.moeller.net/flip-cat/?edition=HPLTE&startpage=5.84>