

TS8G-64GPSD520I

2.5" Solid State Disk

Description

Transcend PSD is a series of 2.5 PATA SSD with high performance and advanced flash control techniques. Due to smaller size (fit the standard dimensions of 2.5" IDE Hard Disk Drives), huge capacity, high speed, and low power consumption, Solid State Disk is perfect replacement storage device for PCs, Laptops, gaming systems, and handheld devices.

Placement



Features

- RoHS compliant products
- Supports LBA 48bit addressing.
- Fully compatible with devices and OS that support the IDE standard (44-Pin, pitch = 2.00 mm)
- Single Power Supply: 5V±10%
- Operating Temperature: -40°C to 85°C
- Storage Temperature: -40°C to 85°C
- Operating Humidity (Non condensation): 0% to 95%
- Storage Humidity (Non condensation): 0% to 95%
- Built-in ECC (Error Correction Code) functionality and global wear-leveling algorithm ensures highly reliable of data transfer
- True IDE Mode supports:
 - ✓ Ultra DMA Mode 0 to Ultra DMA Mode 6
 - ✓ MultiWord DMA Mode 0 to MultiWord DMA Mode 2
 - ✓ PIO Mode 0 to PIO Mode 4
- Shock resistance
- MTBF : 1,000,000 hours
- Support S.M.A.R.T (Self-defined) to monitor Erase Count for lifetime evaluation.
- Support Security Command
- Support Static Data Refresh, Early Retirement to extend product life

Dimensions

Side	Millimeters	Inches
A	100.30 ± 0.40	3.949 ± 0.016
B	69.85 ± 0.20	2.750 ± 0.008
C	7.40 ± 0.15	0.292 ± 0.004

TS8G-64GPSD520I

2.5" Solid State Disk

Specifications

Physical Specification		
Form Factor	2.5-inch HDD	
Storage Capacities	8 GB to 64 GB	
Dimensions (mm)	Length	100.3 0 ± 0.40
	Width	69.85 ± 0.20
	Height	7.40 ± 0.15
Input Voltage	5V ± 10%	
Weight	55g ± 5g	
Connector	44-Pin standard IDE/ATA connector (Pitch 2.0 mm)	

Capacity					
Model P/N	Cylinder	Head	Sector	User LBA	Physical Capacity
TS8GPSD520I	15526	16	63	15,650,208	8,012,906,496 Byte
TS16GPSD520I	16383	15	63	31,277,056	16,013,852,672 Byte
TS32GPSD520I	16383	15	63	62,533,632	32,018,219,584 Byte
TS64GPSD520I	16383	15	63	125,044,736	64,002,424,832 Byte

Note. PSD520I series is shipped with RAW format. Inquiry for formatted device please contact with sales/PM.

Performance				
	Sequential Read	Sequential Write	Random 4K Read	Random 4K Write
8GB	116	65	10.14	1.378
16GB	119	100	10.99	1.75
32GB	118.5	102.4	11.57	1.830
64GB	111	97	10.96	1.849

Note : Test by Crystal Disk Mark V3.0.1, 500MB size @25 °C, P5K-VM(ICH 9), 1GB RAM * 2, IDE interface support up to UDMA6, Windows® XP SP3

Power consumption (mA)				
Capacity	8GB	16GB	32GB	64GB
Read			252.8	266
Write			257.3	268
Idle			8.7	7.8

TS8G~64GPSD520I

2.5" Solid State Disk

Note: All data above are maximum value from various test patterns.

Endurance				
Capacity	8GB	16GB	32GB	64GB
Tera Byte Write	166.6 TBW	333.3 TBW	666.6 TBW	1333.2 TBW

Note: Based on JEDEC JESD218A specification, Client Application Class. And based on the following scenario: Active use: 40°C, 8hrs/day; Retention use: 30°C 1year

Interface			
Part Number	Interface	Transfer Mode	Connector
TS8G~64GPSD520I	True IDE mode	Ultra DMA mode 0~6 Multi-Word DMA Mode 0~2 PIO Mode 0 ~ 4	44pin 2mm pitch Pin male Header

Environmental Specifications	
Operating Temperature	-40 °C to 85 °C
Storage Temperature	-40 °C to 85 °C
Operating Humidity (Non condensation)	0% to 95%
Storage Humidity (Non condensation)	0% to 95%

SHOCK & Vibration Test		
	Condition	Standard
Mechanical Shock Test	1500G, 0.5ms, 3 axes	IEC 60068-2-27
Vibration Test	20G (Peak-to-Peak) 20Hz to 2000Hz (Frequency)	IEC 60068-2-6

Note: If Third party report is needed, please contact with sales/PM.

EMC/EMI	
Compliance	CE, FCC and BSMI

Note: If Third party report is needed, please contact with sales/PM.

Interface Specification	
Jumper Settings	Master/Slave/Cable-select Settings
ATA Compatibility	ATA/ATAPI 8
	UDMA Modes 6

Package Dimensions

Below figure illustrates the Transcend 2.5" Solid State Disk. All dimensions are in mm.

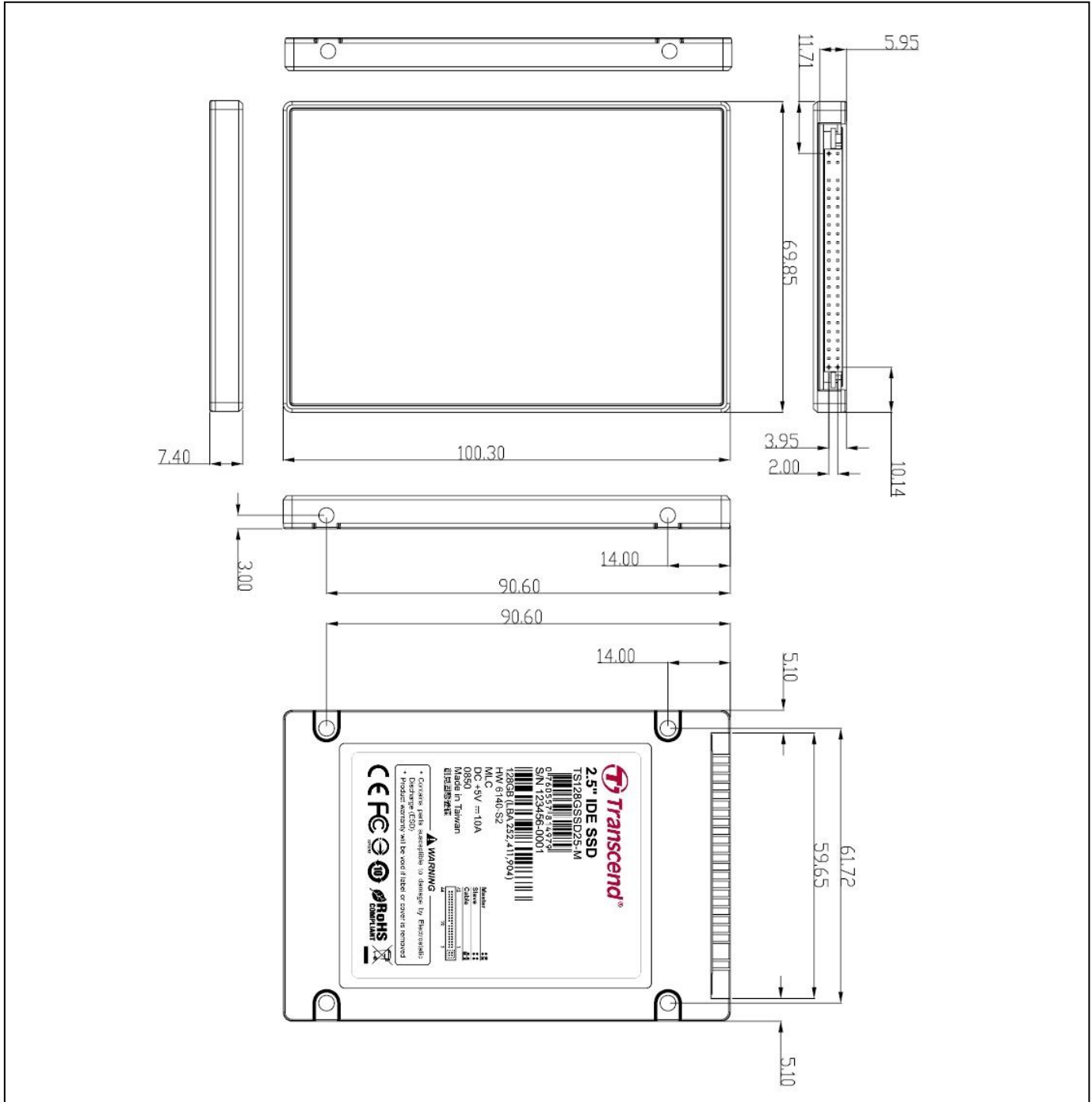

*Note: Tighten mounting screws with no more than 1.0Kg-cm (0.07ft-lbs) of torque.

Pin Assignments

Pin No.	Pin Name	Pin No.	Pin Name
01	-RESET	02	GND
03	DD7	04	DD8
05	DD6	06	DD9
07	DD5	08	DD10
09	DD4	10	DD11
11	DD3	12	DD12
13	DD2	14	DD13
15	DD1	16	DD14
17	DD0	18	DD15
19	GND	20	KEY-PIN (OPEN)
21	DMARQ	22	GND
23	-DIOW : STOP	24	GND
25	-DIOR : -HDMARDY : HSTROBE	26	GND
27	IORDY : DDMARDY : DSTROBE	28	CSEL
29	-DMACK	30	GND
31	INTRQ	32	IOCS16B
33	DA1	34	-PDIAG : -CBLID
35	DA0	36	DA2
37	-CS0	38	-CS1
39	-DASP	40	GND
41	VCC	42	VCC
43	GND	44	NC (No Connect)

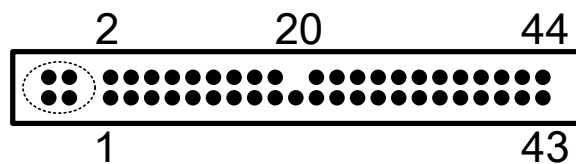
Pin Layout

Master Mode

Slave Mode

Cable Select

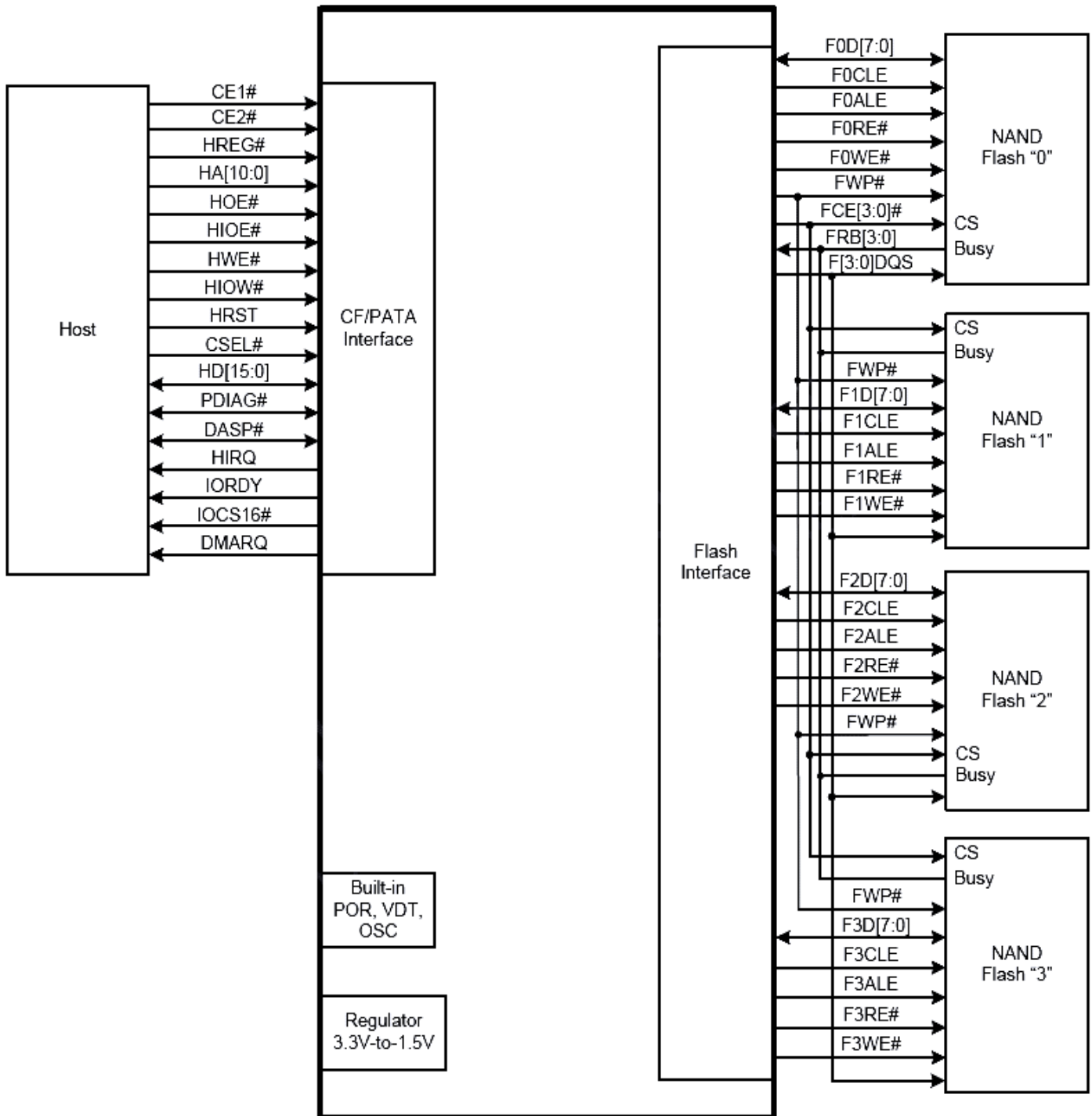
Block Diagram



Reliability

1. Global Wear Leveling – Advanced algorithm to enhance the Wear-Leveling Efficiency

There are 3 main processes in SMI global wear leveling approaches:

- A. Record the block erase count and save in the wear-leveling table.
- B. Find the static-block and save it in wear-leveling pointer.
- C. Check the erase count when the block popped from spare pool. If the block erase count is bigger than WEARCNT, then it swapped the static-block and over-count-block.

After actual test, global wear leveling successfully even the erase count of every block; hence, it can extend the life expectancy of Flash product.

2. StaticDataRefresh Technology – Keeping Data Healthy

In the Flash technology, multiple charge levels are used to store data. There are many variants that would disturb the charge inside a Flash cell. These variants can be: time, read operations, undesired charge, heat, etc; each variant would create a charge loss, and the contents shift in their charge levels slightly. In our everyday usage – more than 60% are repeated read operations, the accumulated charge loss would eventually result in the data loss.

Normally, ECC engine corrections are taken place without affecting the host normal operations. As time passes by, the number of error bits accumulated in the read transaction exceeds the correcting capability of the ECC engine, resulting in corrupted data being sent to the host.

To prevent this, Transcend's PSD520I monitor the error bit levels at each read operation; when it reaches the preset threshold value, the controller automatically performs data refresh to "restore" the correct charge levels in the cell. This implementation practically restores the data to its original, error-free state, and hence, lengthening the life of the data.

3. EarlyRetirement – Avoiding Data Loss Due to Weak Block.

The StaticDataRefresh feature functions well when the cells in a block are still healthy. As the block ages over time, it cannot store charge reliably anymore, EarlyRetirement enters the scene.

EarlyRetirement works by moving the static data to another block (a health block) before the previously used block becomes completely incapable of holding charges for data. When the charge loss error level exceeds another threshold value (higher from that for StaticDataRefresh), the controller automatically moves its data to another block. In addition, the original block is then marked as a bad block, which prevents its further use, and thus the block enters the state of "EarlyRetirement." Note that, through this process, the incorrect data are detected and effectively corrected by the ECC engine, thus the data in the new block is stored error-free.

4. Advanced Power Shield – Avoiding Data Loss during Power Failure

When a power failure takes place, the line voltage drops. When it reaches the first Logic-Freeze Threshold, the core controller is held at a steady state. Here are some implications. First, it ceases the communication with the host. This prevents the host from sending in further address/instructions/data that may be corrupted. During power disturbance, the host is likely experiencing a voltage drop, so the transmission integrity cannot be guaranteed. Second, it stops the information sending to the Flash. This prevents the controller from corrupting the address/data being transmitted to the Flash, and corrupting the Flash contents inadvertently.

Further more, Advanced Power Shield cut off the connection between host power and turn off the controller to reserve most of the energy for NAND Flash to complete programming. Due to MLC structure, an interrupted programming may damage a paired page which cause the previous written data lost.

Support ATA/ATAPI Command List

Support ATA/ATAPI Command	Code	Protocol
General Feature Set		
EXECUTE DIAGNOSTICS	90h	Device diagnostic
FLUSH CACHE	E7h	Non-data
IDENTIFY DEVICE	ECh	PIO data-In
READ DMA	C8h	DMA
READ MULTIPLE	C4h	PIO data-In
READ SECTOR(S)	20h	PIO data-In
READ VERIFY SECTOR(S)	40h or 41h	Non-data
SET FEATURES	EFh	Non-data
SET MULTIPLE MODE	C6h	Non-data
WRITE DMA	CAh	DMA
WRITE MULTIPLE	C5h	PIO data-out
WRITE SECTOR(S)	30h	PIO data-out
NOP	00h	Non-data
READ BUFFER	E4h	PIO data-In
WRITE BUFFER	E8h	PIO data-out
Power Management Feature Set		
CHECK POWER MODE	E5h or 98h	Non-data
IDLE	E3h or 97h	Non-data
IDLE IMMEDIATE	E1h or 95h	Non-data
SLEEP	E6h or 99h	Non-data
STANDBY	E2h or 96h	Non-data
STANDBY IMMEDIATE	E0h or 94h	Non-data
Security Feature Set		
SECURITY SET PASSWORD	F1h	PIO data-out
SECURITY UNLOCK	F2h	PIO data-out
SECURITY ERASE PREPARE	F3h	Non-data
SECURITY ERASE UNIT	F4h	PIO data-out
SECURITY FREEZE LOCK	F5h	Non-data
SECURITY DISABLE PASSWORD	F6h	PIO data-out
SMART Feature Set		
SMART Disable Operations	B0h	Non-data
SMART Enable/Disable Autosave	B0h	Non-data
SMART Enable Operations	B0h	Non-data
SMART Return Status	B0h	Non-data
SMART Execute Off-Line Immediate	B0h	Non-data
SMART Read Data	B0h	PIO data-In
Host Protected Area Feature Set		
Read Native Max Address	F8h	Non-data
Set Max Address	F9h	Non-data
Set Max Set Password	F9h	PIO data-out
Set Max Lock	F9h	Non-data
Set Max Freeze Lock	F9h	Non-data
Set Max Unlock	F9h	PIO data-out

General Feature Set

FLUSH CACHE (E7h)

This command is used by the host to request the device to flush the write cache. If there is data in the write cache, that data shall be written to the media. The BSY bit shall remain set to one until all data has been successfully written or an error occurs.

IDENTIFY DEVICE (ECh)

This commands read out 512 Bytes of drive parameter information. Parameter Information consists of the arrangement and value as shown in the following table. This command enables the host to receive the Identify Drive Information from the device.

Identify Device Information Default Value

Word Address	Default value (Hex)	Total Bytes	Data Field Type Information
0	0x044A	2	General configuration
1	0xFFFF	2	Default number of cylinders
2	0x0000	2	Reserved
3	0x00XX	2	Default number of heads
4-5	0x02400000	4	Obsolete
6	0xFFFF	2	Default number of sectors per track
7 - 8	0XXXXXXXX	4	Number of sectors per card (Word 7 = MSW, Word 8 = LSW)
9	0x0000	2	Obsolete
10 - 19	0XXXXX	20	Serial number in ASCII (Right justified)
20-21	0x00020002	4	Obsolete
22	0x0000	2	Obsolete
23 - 26	0XXXXX	8	Firmware revision in ASCII. Big Endian Byte Order in Word
27 - 46	0XXXXX	40	Model number in ASCII (Left justified). Big Endian Byte Order in Word.
47	0x8001	2	Maximum number of sectors on Read/Write Multiple command
48	0x0000	2	Reserved
49-50	0XXXXX	4	Capabilities
51-52	0x00000200	4	PIO data transfer cycle timing mode
53	0x0007	2	Field validity
54	0XXXXX	2	Current numbers of cylinders
55	0XXXXX	2	Current numbers of heads
56	0XXXXX	2	Current sectors per track
57 - 58	0XXXXX	4	Current capacity in sectors (LBAs) (Word57 = LSW , Word58 = MSW)
59	0x0000	2	Multiple sector setting
60 - 61	0XXXXX	4	Total number of sectors addressable in LBA Mode

TS8G-64GPSD520I
2.5" Solid State Disk

Word Address	Default value (Hex)	Total Bytes	Data Field Type Information
62	0x0000	2	Reserved
63	0x0007	2	Multiword DMA transfer
64	0x0003	2	Advanced PIO modes supported
65	0x0078	2	Minimum Multiword DMA transfer cycle time per word
66	0x0078	2	Recommended Multiword DMA transfer cycle time.
67	0x0078	2	Minimum PIO transfer cycle time without flow control
68	0x0078	2	Minimum PIO transfer cycle time with IORDY flow control
69 -74	0x0000	18	Reserved
75	0x0000	2	Reserved
76-79	0x0000	8	Reserved
80	0x0800	2	Major version number (ATAPI-8)
81	0x0000	2	Minor version number
82	0x7028	2	Command sets supported 0
83	0x5000	2	Command sets supported 1
84	0x4000	2	Command sets supported 2
85	0x0000	2	Command sets enabled 0
86	0x0000	2	Command sets enabled 1
87	0x0000	2	Command sets enabled 2
88	0x007F	2	Ultra DMA mode supported and selected
89	0x0000	2	Time required for Security erase unit completion
90	0x0000	2	Time required for Enhanced security erase unit completion
91	0x0000	2	Current Advanced power management value
92	0x0000	3	Master Password Revision Code
93	0x604F 0x6F00 0x603F	2	<ul style="list-style-type: none"> • Hardware reset result (Master only) • Hardware reset result (Slave only) • Hardware reset result (Master w/ slave present)
94 - 127	0x0000	68	Reserved
128	0x0001	2	Security Status
129-159	0XXXXX	62	Vendor specific
160	0x0000	2	Power requirement description
161	0x0000	2	Reserved
162	0x0000	2	Key management schemes support
163	0x0000	2	CF Advanced True IDE Timing Mode Capability and Setting
164	0x0000	2	<ul style="list-style-type: none"> • CF Advanced PCMCIA I/O and Memory Timing Mode Capability and Setting • 80 ns cycle in memory and I/O mode
165 - 175	0x0000	22	Reserved
176 - 255	0x0000	160	Reserved

READ DMA (C8h)

Read data from sectors during Ultra DMA and Multiword DMA transfer. Use the SET FEATURES command to specify the mode value. A sector count of zero requests 256 sectors.

READ MULTIPLE (C4h)

This command performs similarly to the Read Sectors command. Interrupts are not generated on each sector, but on the transfer of a block which contains the number of sectors defined by a Set Multiple command.

READ SECTOR(S) (20h)

This command reads 1 to 256 sectors as specified in the Sector Count register from sectors which is set by Sector number register. A sector count of 0 requests 256 sectors. The transfer begins specified in the Sector Number register.

READ VERIFY SECTOR(S) (40h/41h)

This command verifies one or more sectors on the drive by transferring data from the flash media to the data buffer in the drive and verifying that the ECC is correct. This command is identical to the Read Sectors command, except that DRQ is never set and no data is transferred to the host.

SET FEATURES (EFh)

This command set parameter to Features register and set drive's operation. For transfer mode, parameter is set to Sector Count register. This command is used by the host to establish or select certain features.

SET MULTIPLE MODE (C6h)

This command enables the device to perform READ MULTIPLE and WRITE MULTIPLE operations and establishes the block count for these commands.

WRITE DMA (CAh)

Write data to sectors during Ultra DMA and Multiword DMA transfer. Use the SET FEATURES command to specify the mode value.

WRITE MULTIPLE (C5h)

This command is similar to the Write Sectors command. Interrupts are not presented on each sector, but on the transfer of a block which contains the number of sectors defined by Set Multiple command.

WRITE SECTOR(S) (30h)

Write data to a specified number of sectors (1 to 256, as specified with the Sector Count register) from the specified address. Specify "00h" to write 256 sectors.

NOP (00h)

The device shall respond with command aborted. For devices implementing the Overlapped feature set, subcommand code 00h in the Features register shall abort any outstanding queue. Subcommand codes 01h through FFh in the

Features register shall not affect the status of any outstanding queue.

READ BUFFER (E4h)

The READ BUFFER command enables the host to read a 512-byte block of data.

WRITE BUFFER (E8h)

This command enables the host to write the contents of one 512-byte block of data to the device's buffer.

Power Management Feature Set**CHECK POWER MODE (E5h or 98h)**

The host can use this command to determine the current power management mode.

IDLE (E3h or 97h)

This command causes the device to set BSY, enter the Idle mode, clear BSY and generate an interrupt. If sector count is non-zero, the automatic power down mode is enabled. If the sector count is zero, the automatic power mode is disabled.

IDLE IMMEDIATE (E1h or 95h)

This command causes the device to set BSY, enter the Idle(Read) mode, clear BSY and generate an interrupt.

SLEEP (E6h or 99h)

This command causes the device to set BSY, enter the Sleep mode, clear BSY and generate an interrupt.

STANDBY (E2h or 96h)

This command causes the device to set BSY, enter the Sleep mode (which corresponds to the ATA "Standby" Mode), clear BSY and return the interrupt immediately.

STANDBY IMMEDIATE (E0h or 94h)

This command causes the drive to set BSY, enter the Sleep mode (which corresponds to the ATA "Standby" Mode), clear BSY and return the interrupt immediately.

Security Mode Feature Set

SECURITY SET PASSWORD (F1h)

This command set user password or master password. The host outputs sector data with PIO data-out protocol to indicate the information defined in the following table.

Security set Password data content

Word	Content		
0	Control word		
	Bit 0	Identifier	0=set user password 1=set master password
	Bits 1-7	Reserved	
	Bit 8	Security level	0=High 1=Maximum
	Bits 9-15	Reserved	
1-16	Password (32 bytes)		
17-255	Reserved		

SECURITY UNLOCK (F2h)

This command disables LOCKED MODE of the device. This command transfers 512 bytes of data from the host with PIO data-out protocol. The following table defines the content of this information.

Security Unlock information

Word	Content		
0	Control word		
	Bit 0	Identifier	0=compare user password 1=compare master password
	Bits 1-15	Reserved	
1-16	Password (32 bytes)		
17-255	Reserved		

SECURITY DISABLE PASSWORD (F6h)

Disables any previously set user password and cancels the lock. The host transfers 512 bytes of data, as shown in the following table, to the drive. The transferred data contains a user or master password, which the drive compares with the saved password. If they match, the drive cancels the lock. The master password is still saved. It is re-enabled by issuing the SECURITY SET PASSWORD command to re-set a user password.

SECURITY ERASE PREPARE (F3h)

This command shall be issued immediately before the Security Erase Unit command to enable erasing and unlocking. This command prevents accidental loss of data on the drive.

SECURITY ERASE UNIT (F4h)

The host uses this command to transfer 512 bytes of data, as shown in the following table, to the drive. The transferred data contains a user or master password, which the drive compares with the saved password. If they match, the drive deletes user data, disables the user password, and cancels the lock. The master password is still saved. It is re-enabled by issuing the SECURITY SET PASSWORD command to re-set a user password.

SECURITY FREEZE LOCK (F5h)

Causes the drive to enter Frozen mode. Once this command has been executed, the following commands to update a lock result in the Aborted Command error:

- SECURITY SET PASSWORD
- SECURITY UNLOCK
- SECURITY DISABLE PASSWORD
- SECURITY ERASE PREPARE
- SECURITY ERASE UNIT

The drive exits from Frozen mode upon a power-off or hard reset. If the SECURITY FREEZE LOCK command is issued when the drive is placed in Frozen mode, the drive executes the command, staying in Frozen mode.

SMART Feature Set

Transcend IDE SSD supports the SMART command set and define some vendor-specific data to report spare/bad block numbers in each memory management unit. Individual SMART commands are identified by the value placed in the Feature register. Table shows these Feature register values.

SMART Feature Register Values			
D0h	Read Data	D5h	Reserved
D1h	Read Attribute Threshold	D6h	Reserved
D2h	Enable/Disable Autosave	D8h	Enable SMART Operations
D3h	Save Attribute Values	D9h	Disable SMART Operations
D4h	Execute OFF-LINE Immediate	DAh	Return Status

SMART DISABLE OPERATIONS

B0h with a Feature register value of D9h. Disables the SMART function. Upon receiving the command, the drive disables all SMART operations. This setting is maintained when the power is turned off and then back on.

Once this command has been received, all SMART commands other than SMART ENABLE OPERATIONS are

aborted with the Aborted Command error.

This command disables all SMART capabilities including any and all timer and event count functions related exclusively to this feature. After command acceptance, this controller will disable all SMART operations. SMART data is no longer be monitored or saved. The state of SMART is preserved across power cycles.

SMART ENABLE/DISABLE ATTRIBUTE AUTOSAVE

B0h with a Feature register value of D2h. Enables or disables the attribute value autosave function. This command specifies whether the current attribute values are automatically saved to the drive when it changes the mode. This setting is maintained when the power is turned on and off.

SMART ENABL OPERATIONS

B0h with a Feature register value of D8h. Enables the SMART function. This setting is maintained when the power is turned off and then back on. Once the SMART function is enabled, subsequent SMART ENABLE OPERATIONS commands do not affect any parameters

SMART EXECUTE OFF-LINE IMMEDIATE

B0h with the content of the Features register equal to D4h. This command causes the device to immediately initiate the optional set of activities that collect SMART data in an off-line mode and then save this data to the device's non-volatile memory, or execute a self-diagnostic test routine in either captive or off-line mode.

SMART RETURN STATUS

B0h with a Feature register value of DAh. This command causes the device to communicate the reliability status of the device to the host. If a threshold exceeded condition is not detected by the device, the device shall set the LBA Mid register to 4Fh and the LBA High register to C2h. If a threshold exceeded condition is detected by the device, the device shall set the LBA Mid register to F4h and the LBA High register to 2Ch.

SMART Read Data

B0h with the content of the Features register equal to D0h. This command returns the Device SMART data structure to the host.

SMART DATA Structure

The following 512 bytes make up the device SMART data structure. Users can obtain the data by SMART command.

BYTE	F / V	Description
0-1	X	Revision code
2-361	X	Vendor specific
362	V	Off-line data collection status
363	X	Self-test execution status byte
364-365	V	Total time in seconds to complete off-line data collection activity
366	X	Vendor specific
367	F	Off-line data collection capability
368-369	F	SMART capability
370	F	Error logging capability 7-1 Reserved 0 1=Device error logging supported
371	X	Vendor specific
372	F	Short self-test routine recommended polling time (in minutes)
373	F	Extended self-test routine recommended polling time (in minutes)
374	F	Conveyance self-test routine recommended polling time (in minutes)
375-385	R	Reserved
386-395	F	Firmware Version/Date Code
396-399	R	Reserved
400-406	F	'SMI2236'
407-511	R	Reserved

F=the content of the byte is fixed and does not change.

V=the content of the byte is variable and may change depending on the state of the device or the commands executed by the device.

X=the content of the byte is vendor specific and may be fixed or variable.

R=the content of the byte is reserved and shall be zero.

* 4 Byte value : [MSB] [2] [1] [LSB]

SMART Attributes

The following table defines the vendor specific data in byte 2 to 361 of the 512-byte SMART data.

Attribute ID(hex)	Raw Attribute Value						Attribute Name
05	MSB	00	00	00	00	00	New bad block
0C	LSB	MSB	00	00	00	00	Power Cycle Count
C7	LSB			MSB	00	00	Ultra DMA CRC error
A1	LSB	MSB	00	00	00	00	Number of Valid Spare Block
A2	LSB	MSB	00	00	00	00	Number of child block used
A3	LSB	MSB	00	00	00	00	Number of initial invalid Block
A5	LSB			MSB	00	00	Maximum Erase Count
A6	LSB			MSB	00	00	Minimum Erase Count
A7	LSB			MSB	00	00	Average Erase Count

Host Protected Area Feature Set

A reserved area for data storage outside the normal operating system file system is required for several specialized applications. Systems may wish to store configuration data or save memory to the device in a location that the operating systems cannot change. The optional Host Protected Area feature set allows a portion of the device to be reserved for such an area when the device is initially configured.

Ultra DMA data transfer
Ultra DMA data burst timing requirements

Name	Mode 0 (in ns)		Mode 1 (in ns)		Mode 2 (in ns)		Mode 3 (in ns)		Mode 4 (in ns)		Mode 5 (in ns)		Mode 6 (in ns)		Measurement location
	Min	Max	Min	Max	Min	Max	Min	Max	Min	Max	Min	Max	Min	Max	
t _{2CYCTYP}	240		160		120		90		60		40		30		Sender
t _{CYC}	112		73		54		39		25		16.8		13.0		Note 3
t _{2CYC}	230		153		115		86		57		38		29		Sender
t _{DS}	15.0		10.0		7.0		7.0		5.0		4.0		2.6		Recipient
t _{DH}	5.0		5.0		5.0		5.0		5.0		4.6		3.5		Recipient
t _{DVS}	70.0		48.0		31.0		20.0		6.7		4.8		4.0		Sender
t _{DVH}	6.2		6.2		6.2		6.2		6.2		4.8		4.0		Sender
t _{CS}	15.0		10.0		7.0		7.0		5.0		5.0		5.0		Device
t _{CH}	5.0		5.0		5.0		5.0		5.0		5.0		5.0		Device
t _{CVS}	70.0		48.0		31.0		20.0		6.7		10.0		10.0		Host
t _{CVH}	6.2		6.2		6.2		6.2		6.2		10.0		10.0		Host
t _{ZFS}	0		0		0		0		0		35		25		Device
t _{DZFS}	70.0		48.0		31.0		20.0		6.7		25		17.5		Sender
t _{FS}		230		200		170		130		120		90		80	Device
t _{LI}	0	150	0	150	0	150	0	100	0	100	0	75	0	60	Note 4
t _{MLI}	20		20		20		20		20		20		20		Host
t _{UI}	0		0		0		0		0		0		0		Host
t _{AZ}		10		10		10		10		10		10		10	Note 5
t _{ZAH}	20		20		20		20		20		20		20		Host
t _{ZAD}	0		0		0		0		0		0		0		Device
t _{ENV}	20	70	20	70	20	70	20	55	20	55	20	50	20	50	Host
t _{RFS}		75		70		60		60		60		50		50	Sender
t _{RP}	160		125		100		100		100		85		85		Recipient
t _{IORDYZ}		20		20		20		20		20		20		20	Device
t _{ZIORDY}	0		0		0		0		0		0		0		Device
t _{ACK}	20		20		20		20		20		20		20		Host
t _{SS}	50		50		50		50		50		50		50		Sender

Ultra DMA data burst timing descriptions

Name	Comment
------	---------

t _{2CYCTYP}	Typical sustained average two cycle time
t _{CYC}	Cycle time allowing for asymmetry and clock variations (from STROBE edge to STROBE edge)
t _{2CYC}	Two cycle time allowing for clock variations (from rising edge to next rising edge or from falling edge to next falling edge of STROBE)
t _{DS}	Data setup time at recipient (from data valid until STROBE edge)
t _{DH}	Data hold time at recipient (from STROBE edge until data may become invalid)
t _{DVS}	Data valid setup time at sender (from data valid until STROBE edge)
t _{DVH}	Data valid hold time at sender (from STROBE edge until data may become invalid)
t _{CS}	CRC word setup time at device
t _{CH}	CRC word hold time device
t _{CVS}	CRC word valid setup time at host (from CRC valid until DMACK- negation)
t _{CVH}	CRC word valid hold time at sender (from DMACK- negation until CRC may become invalid)
t _{ZFS}	Time from STROBE output released-to-driving until the first transition of critical timing.
t _{DZFS}	Time from data output released-to-driving until the first transition of critical timing.
t _{FS}	First STROBE time (for device to first negate DSTROBE from STOP during a data in burst)
t _{LI}	Limited interlock time
t _{MLI}	Interlock time with minimum
t _{UI}	Unlimited interlock time
t _{AZ}	Maximum time allowed for output drivers to release (from asserted or negated)
t _{ZAH}	Minimum delay time required for output
t _{ZAD}	drivers to assert or negate (from released)
t _{ENV}	Envelope time (from DMACK- to STOP and HDMARDY- during data in burst initiation and from DMACK to STOP during data out burst initiation)
t _{RFS}	Ready-to-final-STROBE time (no STROBE edges shall be sent this long after negation of DMARDY-)
t _{RP}	Ready-to-pause time (that recipient shall wait to pause after negating DMARDY-)
t _{IORDYZ}	Maximum time before releasing IORDY
t _{ZIORDY}	Minimum time before driving IORDY
t _{ACK}	Setup and hold times for DMACK- (before assertion or negation)
t _{SS}	Time from STROBE edge to negation of DMARQ or assertion of STOP (when sender terminates a burst)

Initiating an Ultra DMA data-in burst

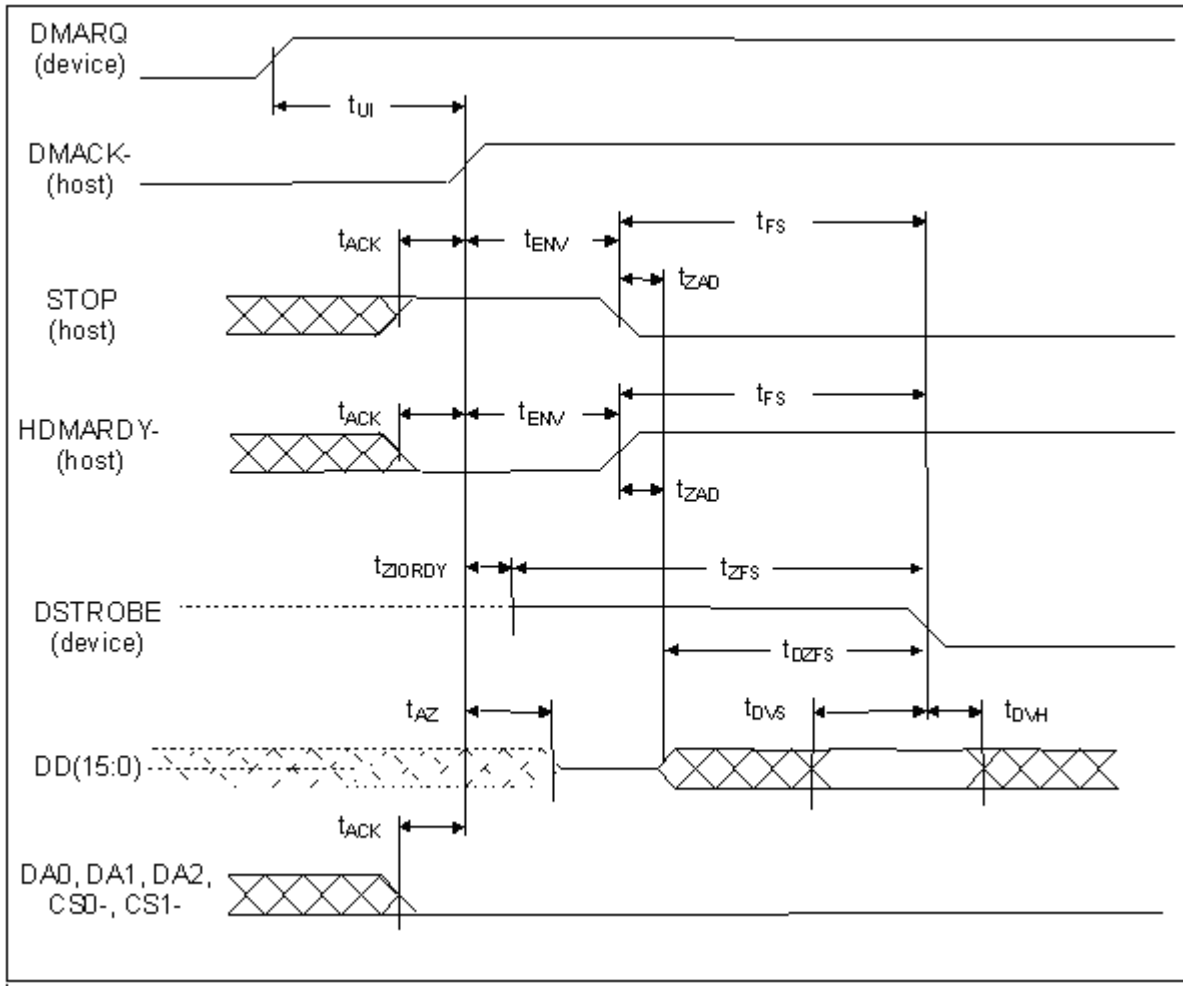

Sustained Ultra DMA data-in burst

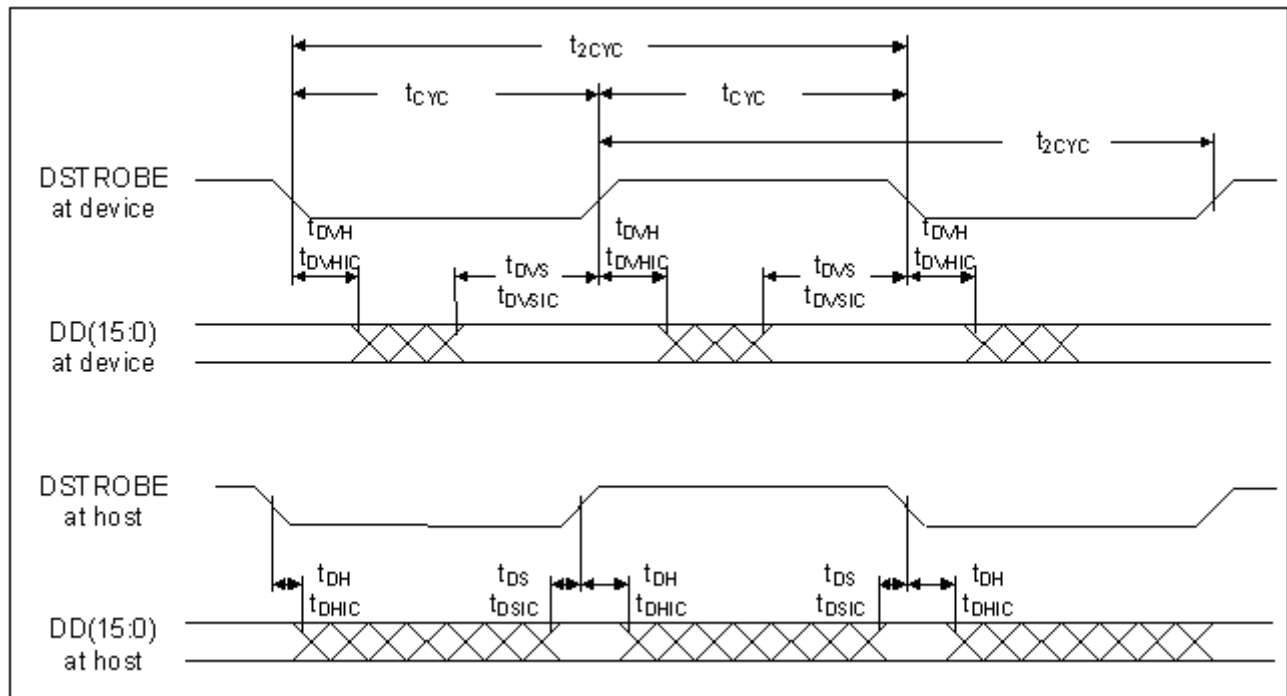

Host pausing an Ultra DMA data-in burst

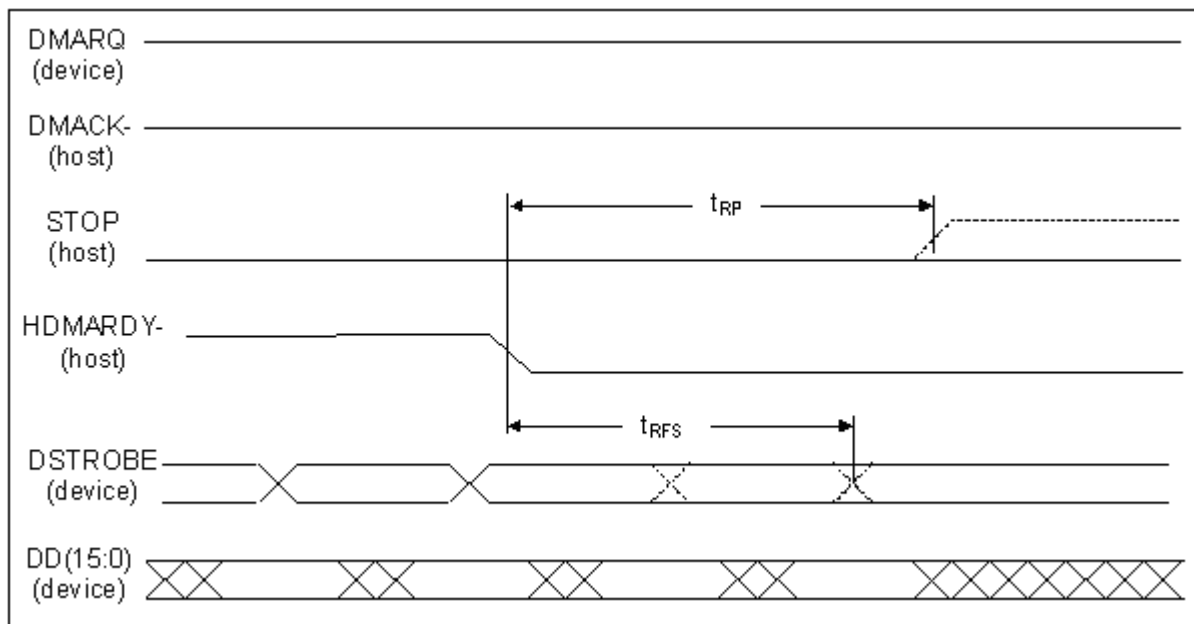

Device terminating an Ultra DMA data-in burst

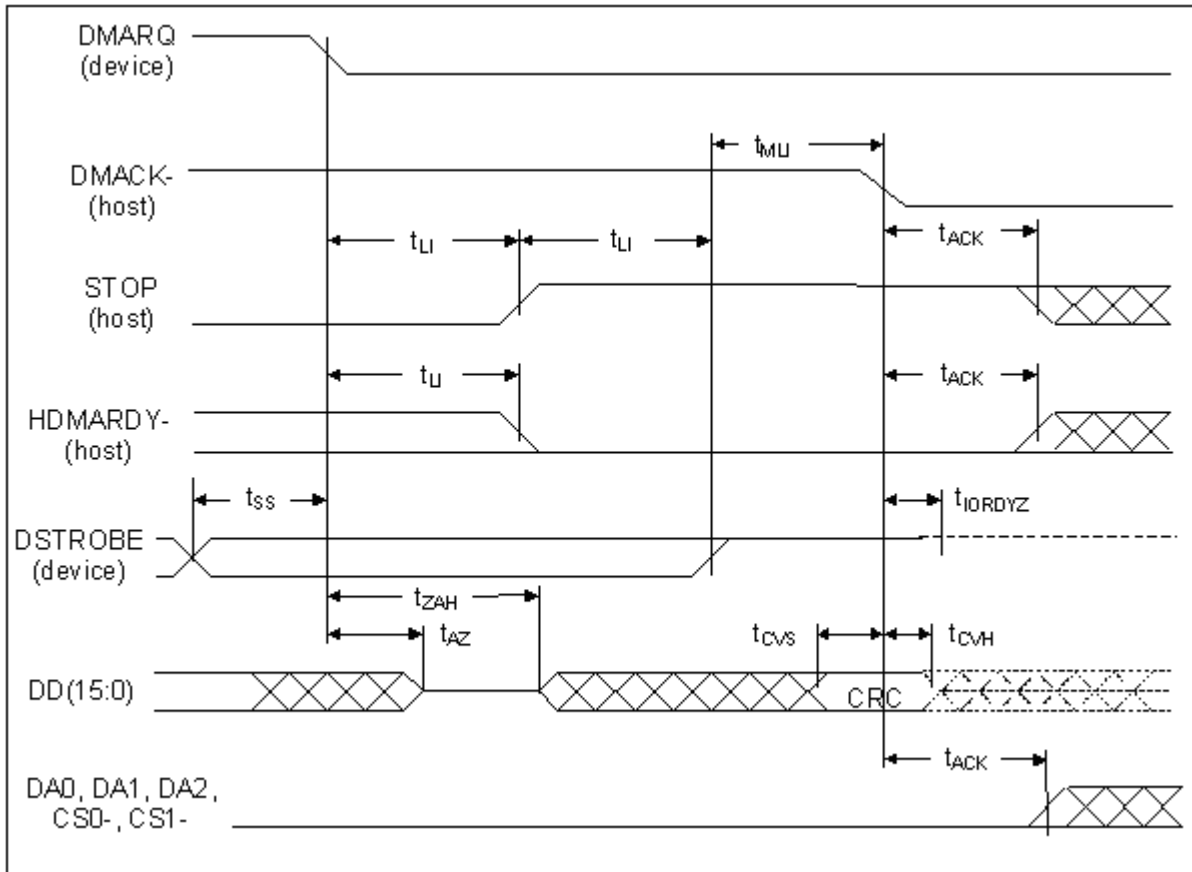

Host terminating an Ultra DMA data-in burst

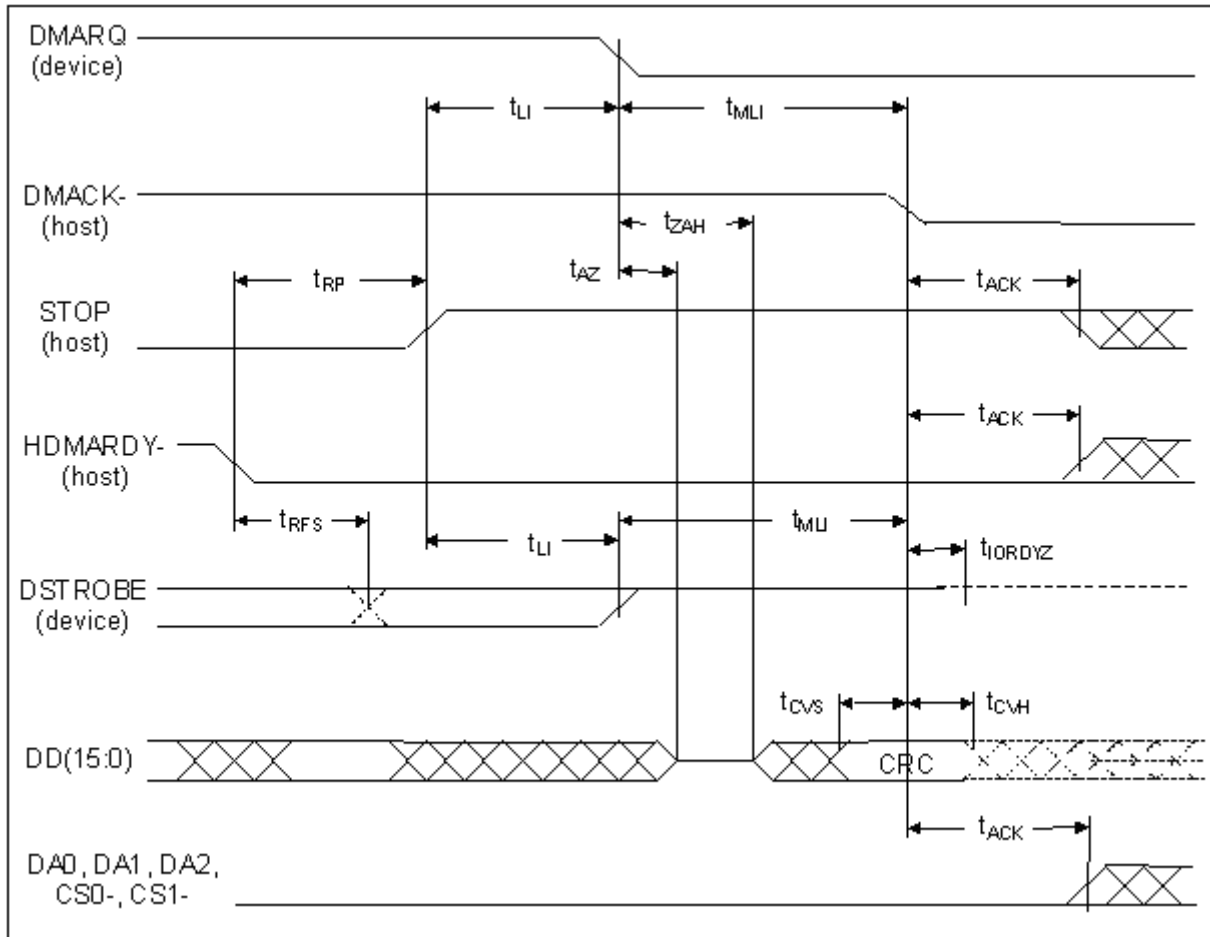

Initiating an Ultra DMA data-out burst

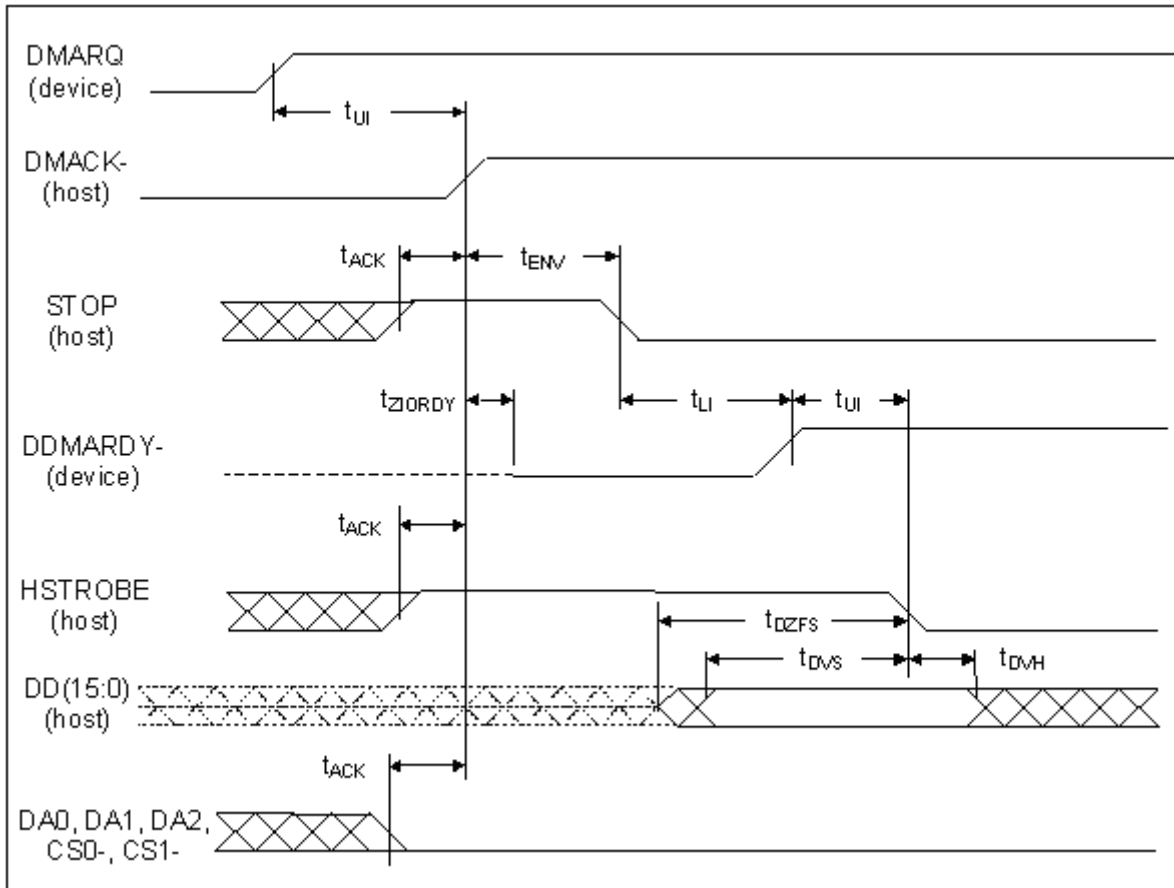

Sustained Ultra DMA data-out burst

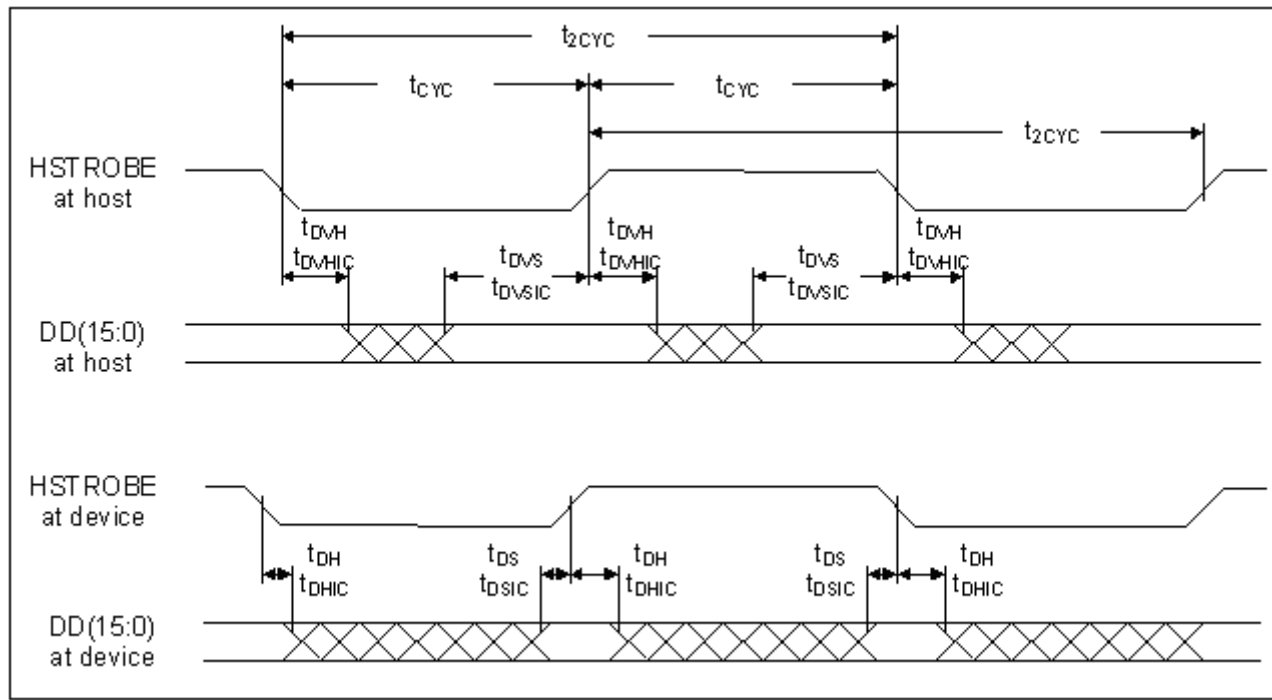

Device pausing an Ultra DMA data-out burst

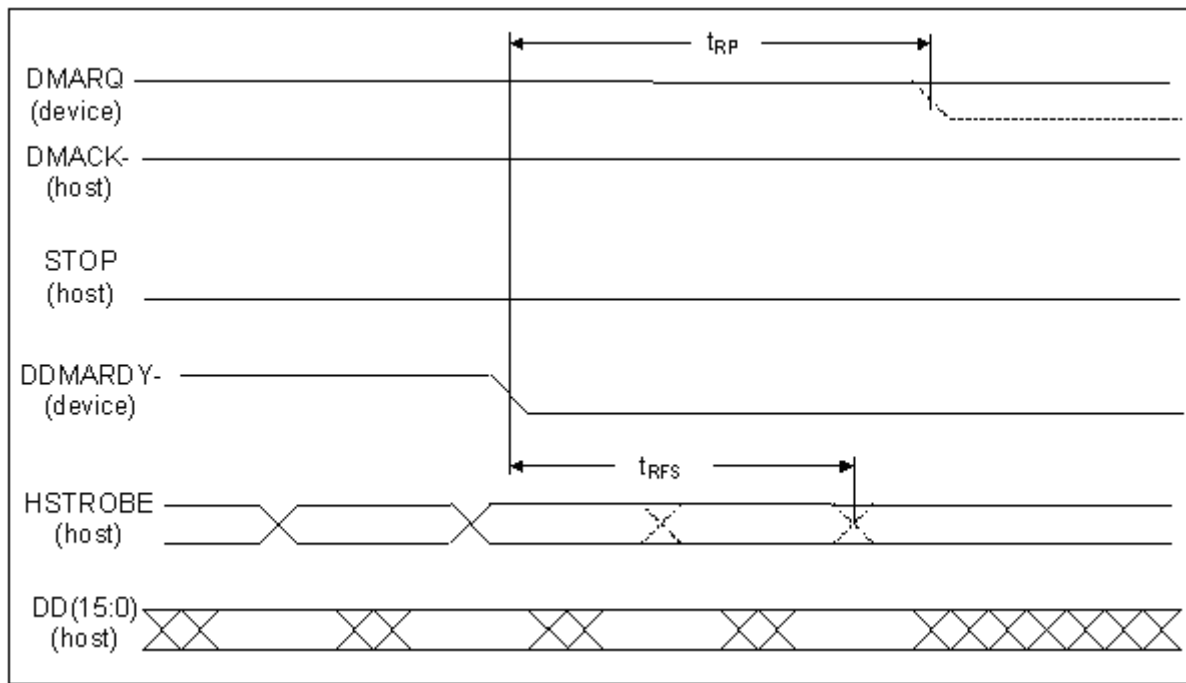

Host terminating an Ultra DMA data-out burst

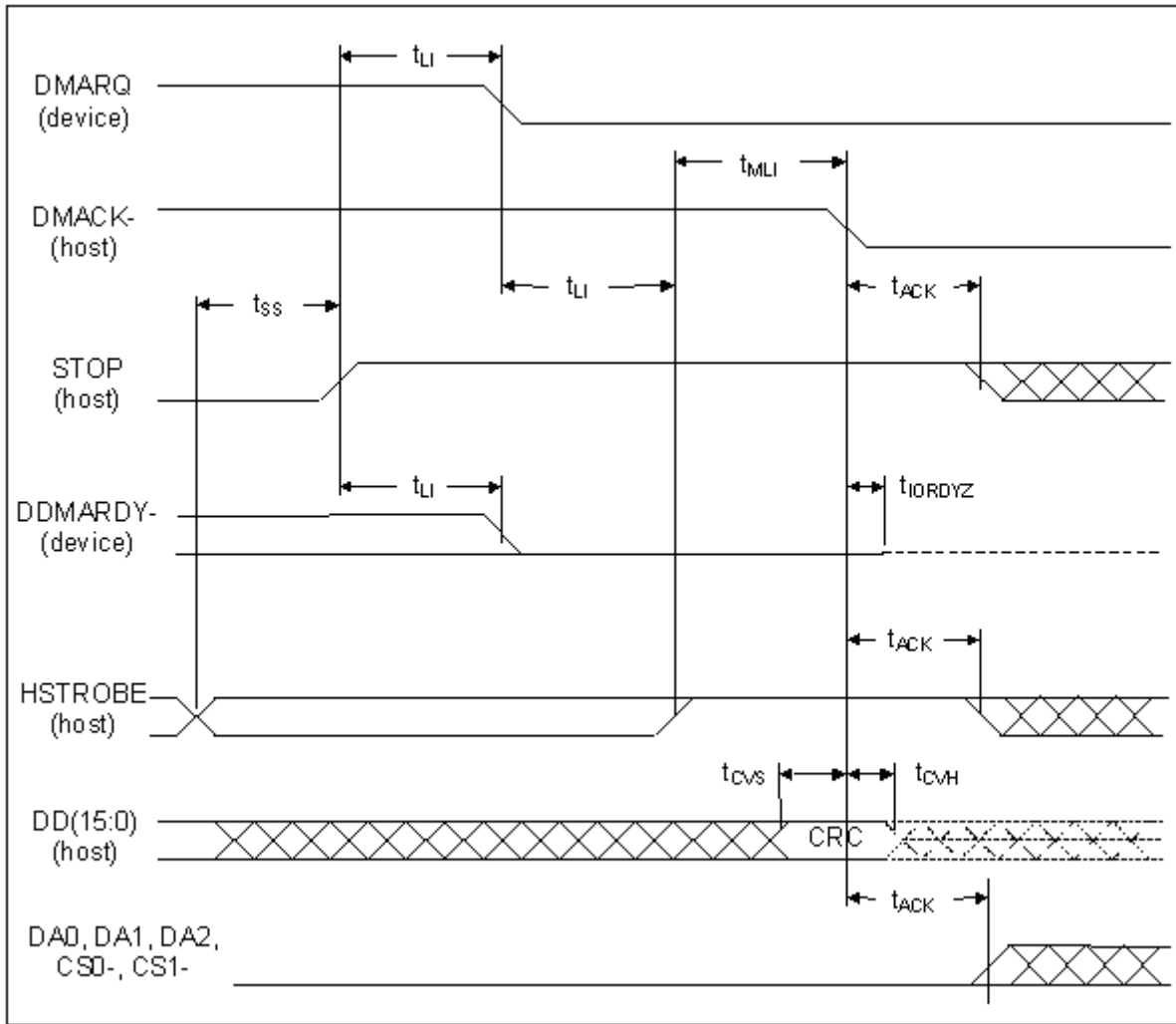

Device terminating an Ultra DMA data-out burst

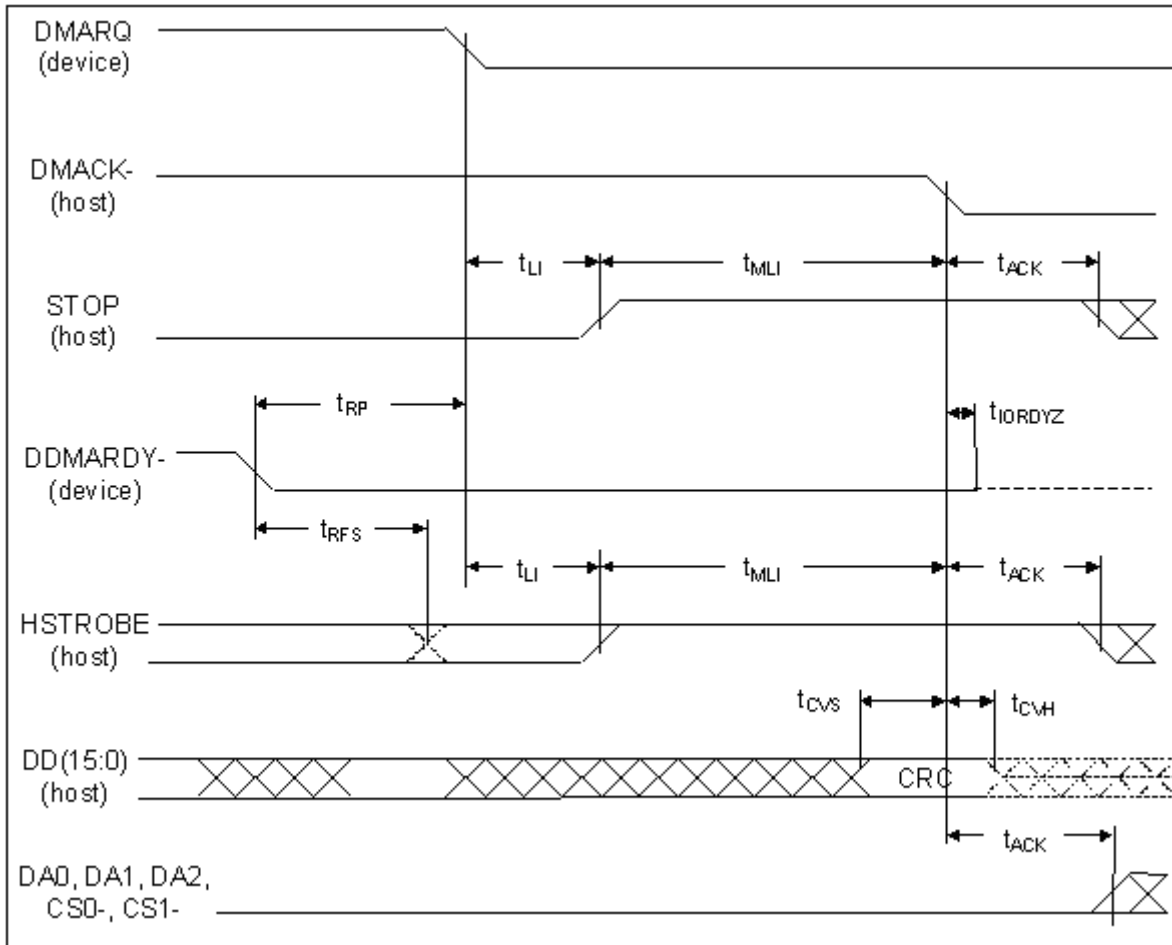

TS8G-64G PSD520I

2.5" Solid State Disk

Multiword DMA data transfer

For Multiword DMA modes 1 and above, the minimum value of t_0 is specified by word 65 in the IDENTIFY DEVICE parameter list. Table 50 defines the minimum value that shall be placed in word 65. Devices shall power-up with mode 0 as the default Multiword DMA mode.

Multiword DMA timing parameters		Mode 0 ns	Mode 1 ns	Mode 2 ns	Note
t_0	Cycle time (min)	480	150	120	see note
t_D	DIOR-/DIOW- asserted pulse width (min)	215	80	70	see note
t_E	DIOR- data access (max)	150	60	50	
t_F	DIOR- data hold (min)	5	5	5	
t_G	DIOR-/DIOW- data setup (min)	100	30	20	
t_H	DIOW- data hold (min)	20	15	10	
t_I	DMACK to DIOR-/DIOW- setup (min)	0	0	0	
t_J	DIOR-/DIOW- to DMACK hold (min)	20	5	5	
t_{KR}	DIOR- negated pulse width (min)	50	50	25	see note
t_{KW}	DIOW- negated pulse width (min)	215	50	25	see note
t_{LR}	DIOR- to DMARQ delay (max)	120	40	35	
t_{LW}	DIOW- to DMARQ delay (max)	40	40	35	
t_M	CS(1:0) valid to DIOR-/DIOW- (min)	50	30	25	
t_N	CS(1:0) hold (min)	15	10	10	
t_Z	DMACK- to read data released (max)	20	25	25	

NOTE – t_0 is the minimum total cycle time, t_D is the minimum DIOR-/DIOW- assertion time, and t_k (t_{KR} or t_{KW} , as appropriate) is the minimum DIOR-/DIOW- negation time. A host shall lengthen t_D and/or t_k to ensure that t_0 is equal to the value reported in the devices IDENTIFY DEVICE data.

Table – Multiword DMA data transfer

Initiating a Multiword DMA data burst

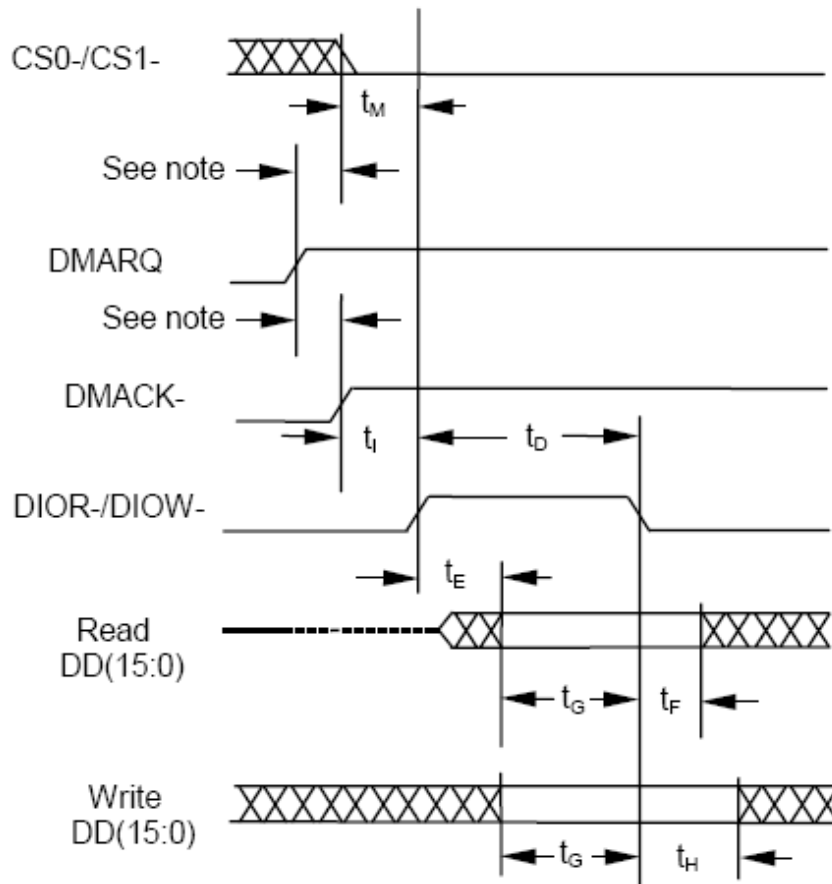

NOTE – The host shall not assert DMACK- or negate both CS0 and CS1 until the assertion of DMARQ is detected. The maximum time from the assertion of DMARQ to the assertion of DMACK- or the negation of both CS0 and CS1 is not defined.

Sustaining a Multiword DMA data burst

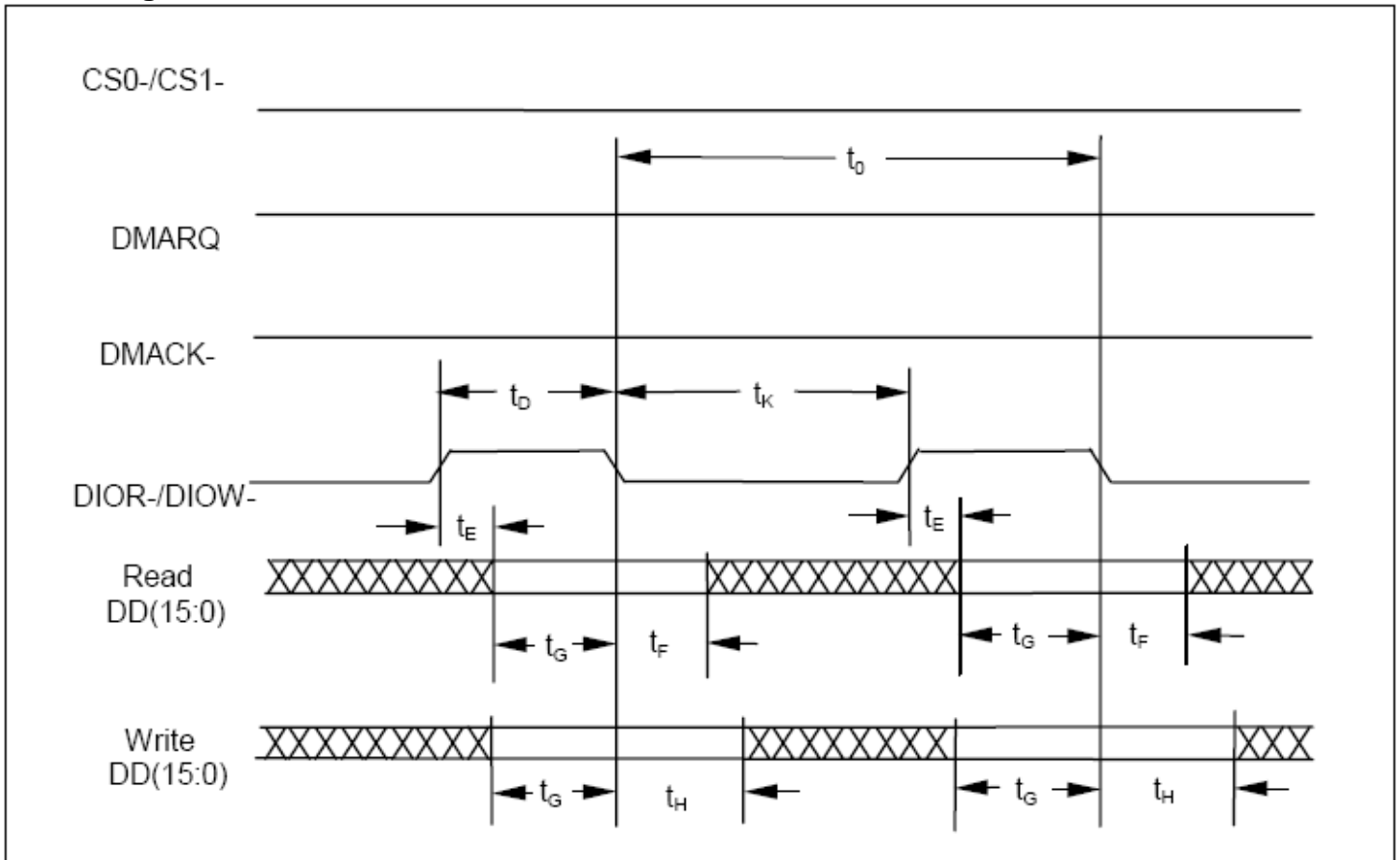

Device terminating a Multiword DMA data burst

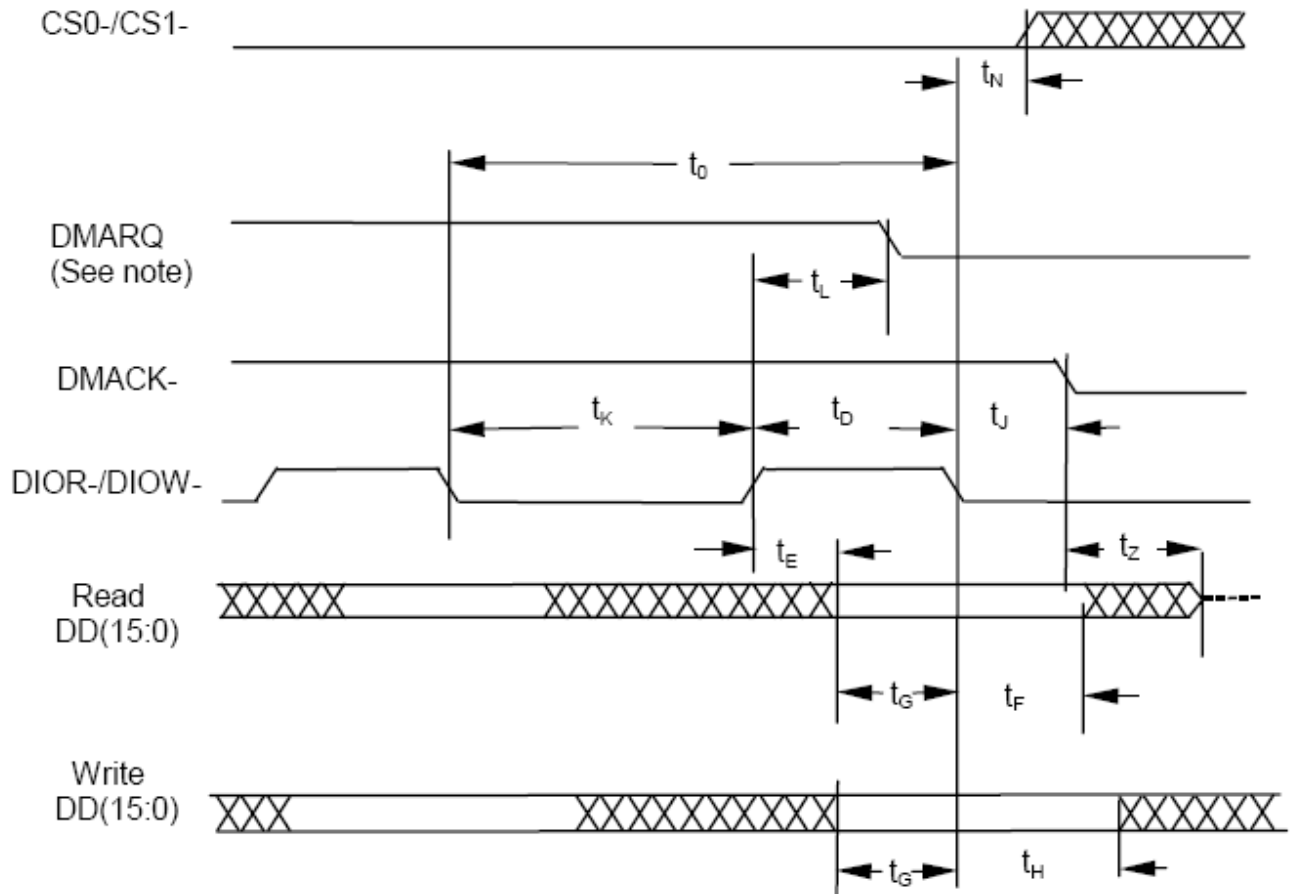

NOTE – To terminate the data burst, the Device shall negate DMARQ within t_L of the assertion of the current DIOR- or DIOW- pulse. The last data word for the burst shall then be transferred by the negation of the current DIOR- or DIOW- pulse. If all data for the command has not been transferred, the device shall reassert DMARQ again at any later time to resume the DMA operation as shown in figure 66.

Host terminating a Multiword DMA data burst

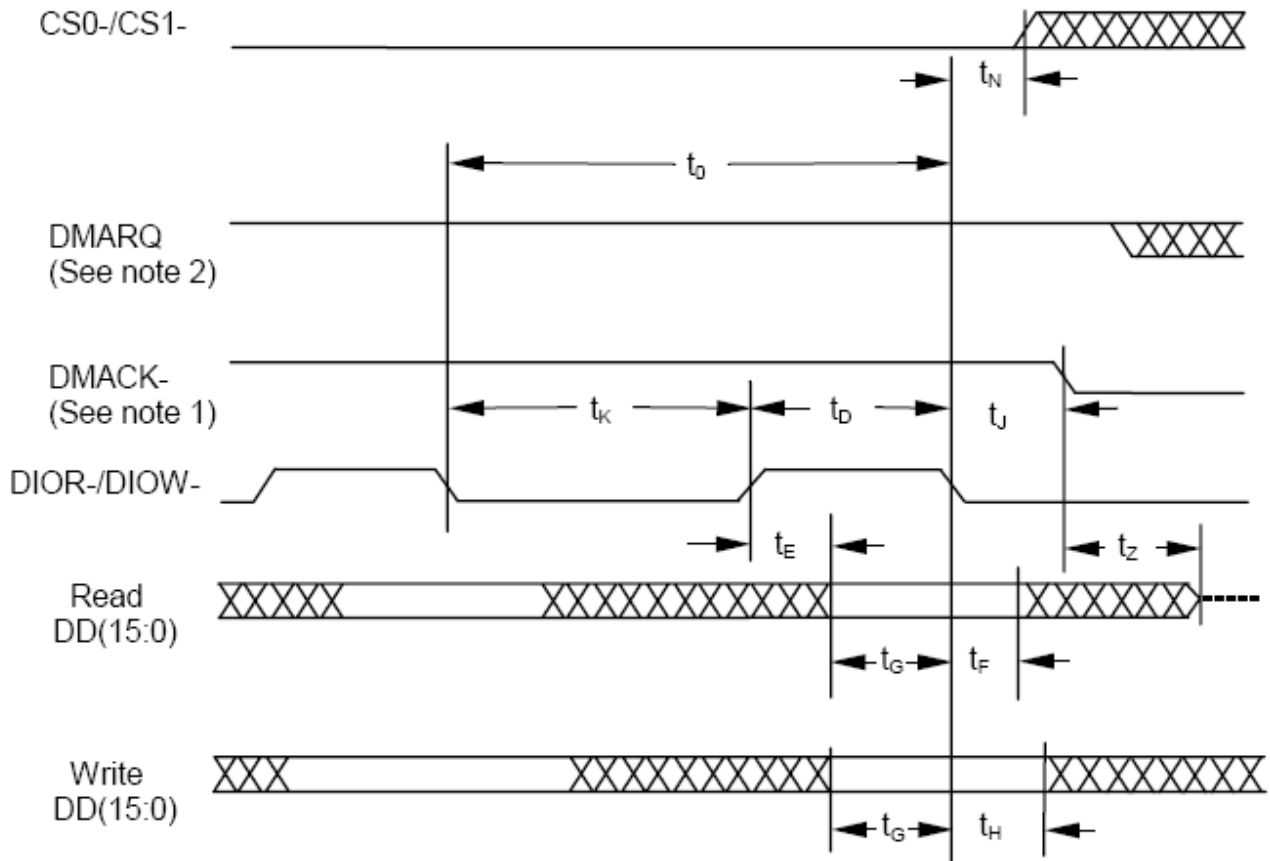

NOTE -

- 1 To terminate the transmission of a data burst, the host shall negate DMACK- within t_J after a DIOR- or DIOW- pulse. No further DIOR- or DIOW- pulses shall be asserted for this burst.
- 2 If the device is able to continue the transfer of data, the device may leave DMARQ asserted and wait for the host to reassert DMACK- or may negate DMARQ at any time after detecting that DMACK- has been negated.

PIO data transfer
PIO timing requirements

PIO timing parameters		Mode 0 ns	Mode 1 ns	Mode 2 ns	Mode 3 ns	Mode 4 ns
t ₀	Cycle time (min)	600	383	240	180	120
t ₁	Address valid to DIOR-/DIOW- setup (min)	70	50	30	30	25
t ₂	DIOR-/DIOW- (min)	165	125	100	80	70
t _{2i}	DIOR-/DIOW- recovery time (min)	-	-	-	70	25
t ₃	DIOW- data setup (min)	60	45	30	30	20
t ₄	DIOW- data hold (min)	30	20	15	10	10
t ₅	DIOR- data setup (min)	50	35	20	20	20
t ₆	DIOR- data hold (min)	5	5	5	5	5
t _{6Z}	DIOR- data tristate (max)	30	30	30	30	30
t ₉	DIOR-/DIOW- to address valid hold (min)	20	15	10	10	10
t _{RD}	Read Data Valid to IORDY active (if IORDY initially low after t _A) (min)	0	0	0	0	0
t _A	IORDY Setup time	35	35	35	35	35
t _B	IORDY Pulse Width (max)	1250	1250	1250	1250	1250
t _C	IORDY assertion to release (max)	5	5	5	5	5

PIO data transfer to/from device

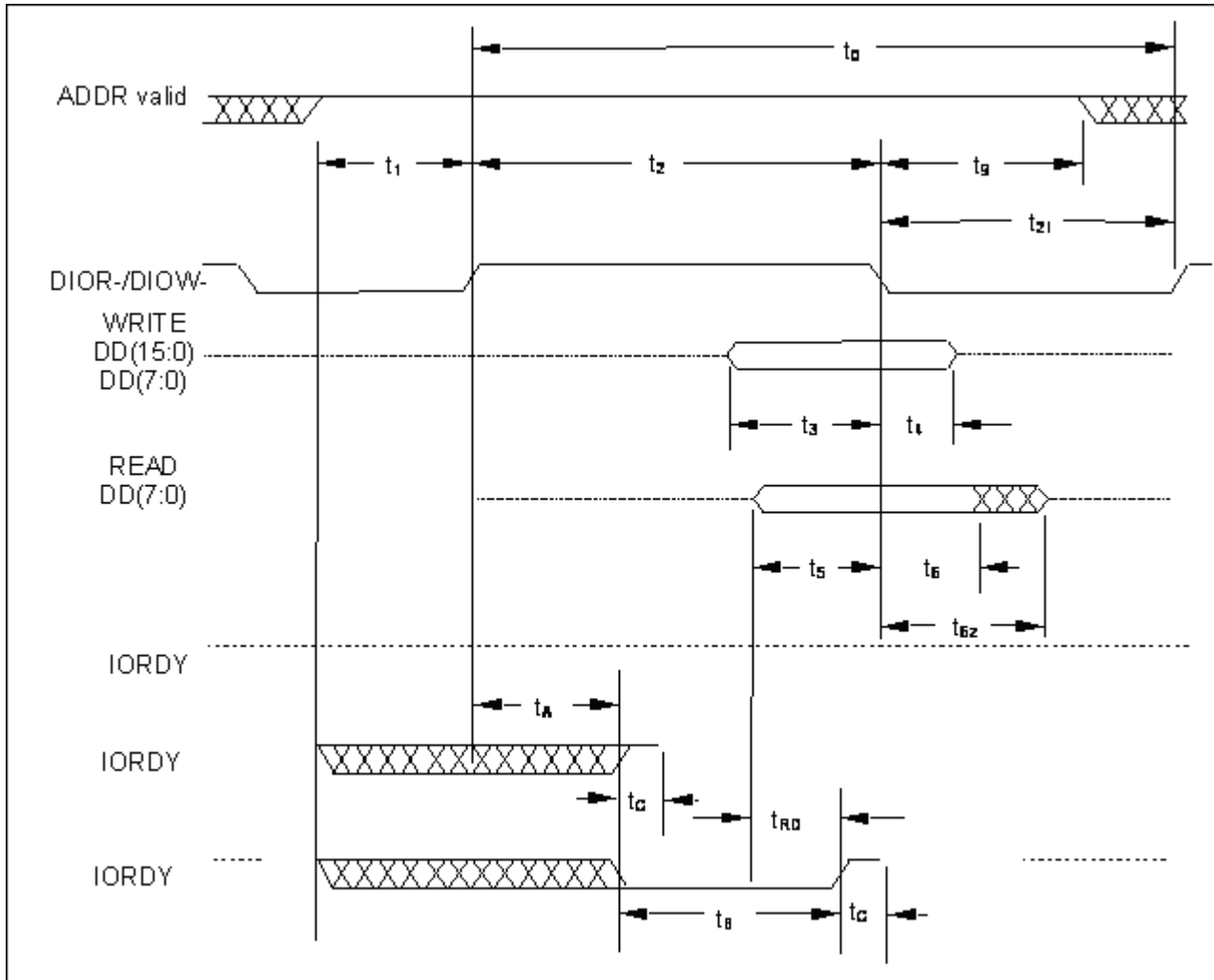

TS8G-64G PSD520I

2.5" Solid State Disk

Ordering Information

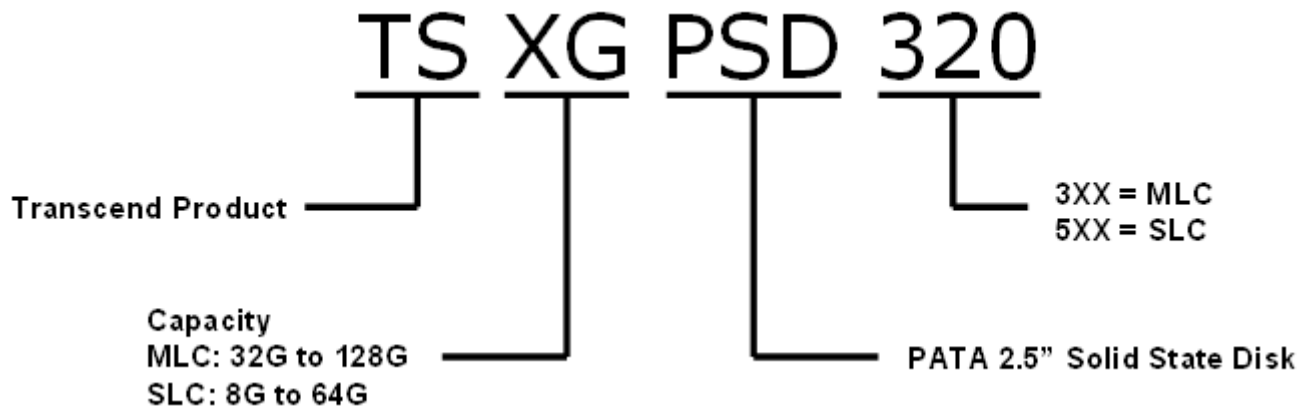

The above technical information is based on industry standard data and has been tested to be reliable. However, Transcend makes no warranty, either expressed or implied, as to its accuracy and assumes no liability in connection with the use of this product. Transcend reserves the right to make changes to the specifications at any time without prior notice.



TAIWAN

No.70, XingZhong Rd., NeiHu Dist., Taipei, Taiwan, R.O.C
TEL +886-2-2792-8000
Fax +886-2-2793-2222
E-mail: sales@transcend.com.tw
www.transcend.com.tw

USA

Los Angeles:

E-mail: sales@transcendusa.com

Maryland:

E-mail: sales_md@transcendusa.com

www.transcendusa.com

CHINA

E-mail: sales@transcendchina.com

www.transcendchina.com

GERMANY

E-mail: vertrieb@transcend.de

www.transcend.de

HONG KONG

E-mail: sales@transcend.com.hk

www.transcendchina.com

JAPAN

E-mail: sales@transcend.co.jp

www.transcend.jp

THE NETHERLANDS

E-mail: sales@transcend.nl

www.transcend.nl

United Kingdom

E-mail: sales@transcend-uk.com

www.transcend-uk.com

KOREA

E-mail: sales@transcend.co.kr

www.transcend.co.kr