

# Cable-sensor

## for air measurements

# type K5S<sub>RS</sub>

Issue of 06/12

### Sensor

1 x Pt100 F0,3 (old cl. B) DIN EN 60751 [E]  
4-wire-circuit -exposed-  
temperature range -50...200°C

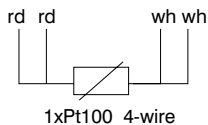

### Protective tube material

1.4571

### Protective tube diameter

ø 4,5 mm slotted

### Installment length L1/ Length of protective tube

40 mm / 60 mm  
100 mm / 120 mm

### Thread

G1/4A

### Cable

TeTe 4x0,14 (200°C)

### Cable length

2500 mm

### Order Example

K5S-E-4LS-200°C-G1/4

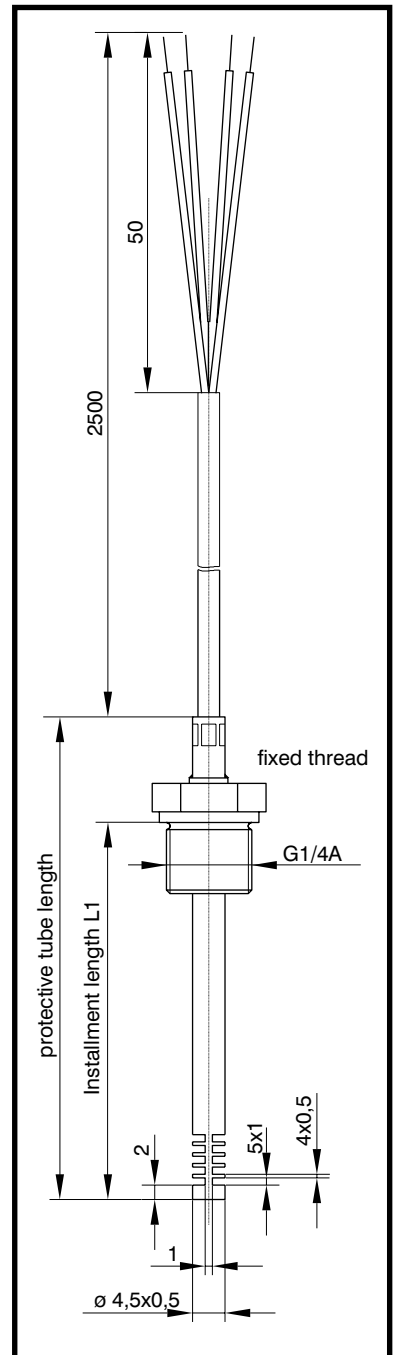

Subject to change without notice

**D - 98716 Geraberg, Gewerbepark 6**

**Tel: +49 (0) 3677 / 7956-0 // Fax: +49 (0) 3677 / 795 625**

**E-Mail: info@electrotherm.de**

**Internet: www.electrotherm.de**