**Ordering number C11552\_BARBARA-S**

Family	Barbara	FWHM	16 degrees
Type	Reflector	Efficiency	90 %
LED	NSBxL110	cd/lm	-
Color	Metal	Gerber File	Available
Diameter	70 mm		
Height	44.7 mm		
Style	Round		
Optic Material	PC		
Holder Material	-		
Fastening	Glue		
Status	Ready		

**Ordering number C11553\_BARBARA-W**

Family	Barbara	FWHM	31 degrees
Type	Reflector	Efficiency	90 %
LED	NSBxL110	cd/lm	-
Color	Metal	Gerber File	Available
Diameter	70 mm		
Height	44.7 mm		
Style	Round		
Optic Material	PC		
Holder Material	-		
Fastening	Glue		
Status	Ready		

**Ordering number C12955\_BARBARA-XW**

Family	Barbara	FWHM	74 degrees
Type	Reflector	Efficiency	91 %
LED	NSBxL110	cd/lm	0.500
Color	White	Gerber File	Available
Diameter	70 mm		
Height	44.7 mm		
Style	Round		
Optic Material	PC		
Holder Material	-		
Fastening	Glue		
Status	Ready		

**NOTE: The typical divergence will be changed by different color, chip size and chip position tolerance. The typical total divergence is the full angle measured where the luminous intensity is half of the peak value.**



## PRODUCT DATASHEET

### Barbara series

last update 4/10/2012



#### GENERAL INFORMATION

- Product series especially designed & optimized for NSBxL110 series of LEDs.
- Special care taken to make light distribution as uniform as possible.
- Reflector is made of aluminium coated PC (120 degrees of Celcius / 248 degrees of Fahrenheit) with protective lacquer (110 degrees of Celcius / 230 degrees of Fahrenheit).
- Fastening to PCB with appropriate adhesive. By clicking link below you can find Ledil recommended glue options.  
[http://www.ledil.com/datasheets/DataSheet\\_GLUES.pdf](http://www.ledil.com/datasheets/DataSheet_GLUES.pdf)

**NOTE 1: We advise customer to ensure the suitability and sufficiency of the bond in the end product. For example, mechanical stress, vibration and holes on the surface of the circuit board weaken the strength of the glue.**

**NOTE 2: All surfaces where glue is applied must be clean, dry and free from grease and dirt. If cleaning of PCB surfaces is needed, please follow strictly the cleaning instructions of your LED manufacturer -this is important as cleaning shall under no circumstances damage LEDs or other electronics components on the PCB.**

**Further note that optical components shall not be cleaned with any chemicals - only micro fiber cloth may be used to remove fingerprints or other traces from handling.**

Relative intensity of C12955\_BARBARA-XW\_(COB-L110)

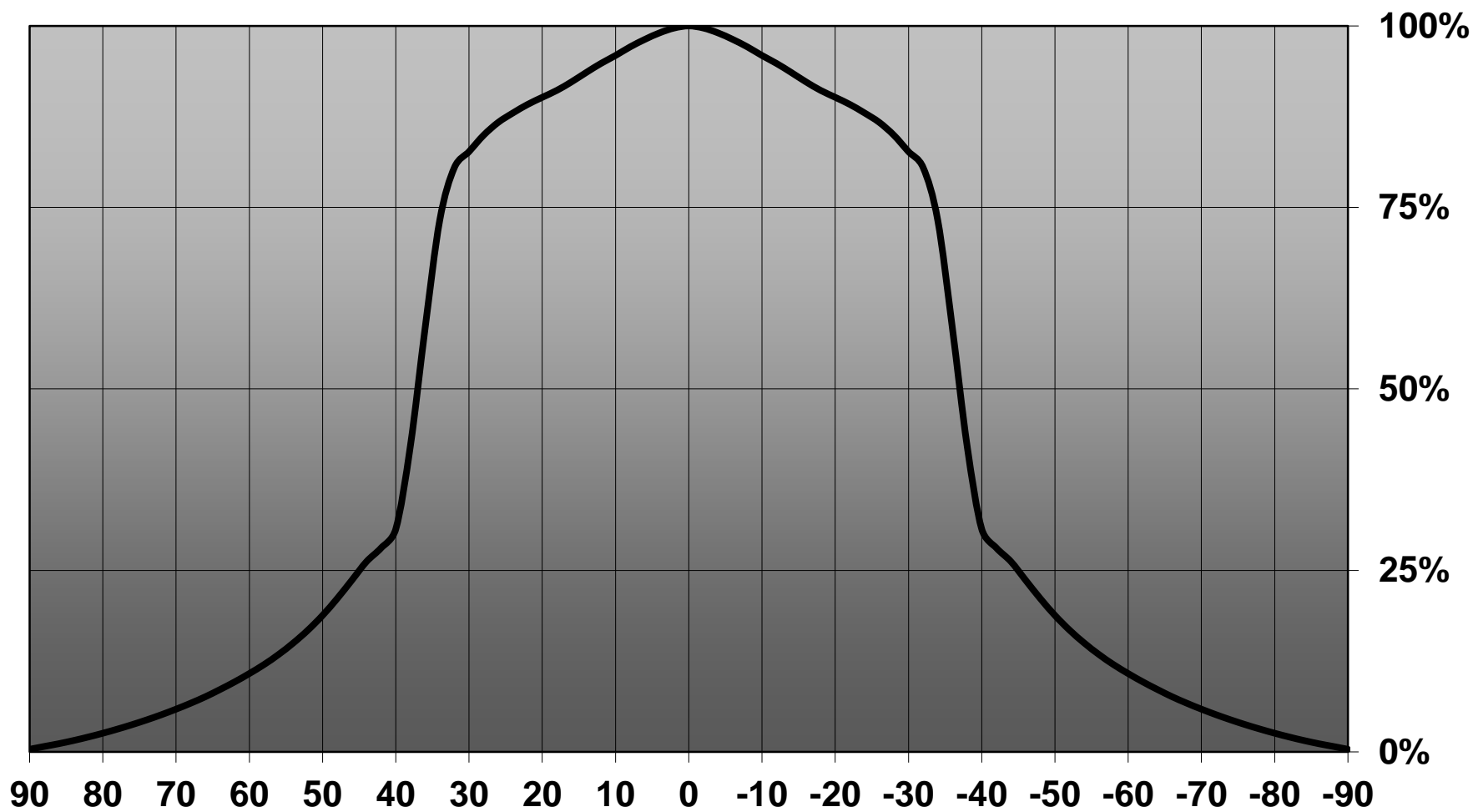

D

C

B

A

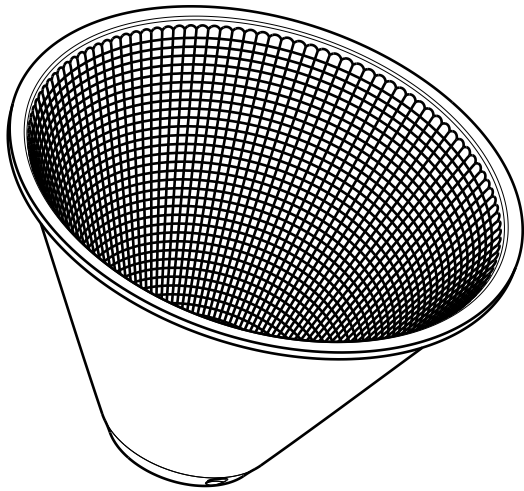

Isometric view

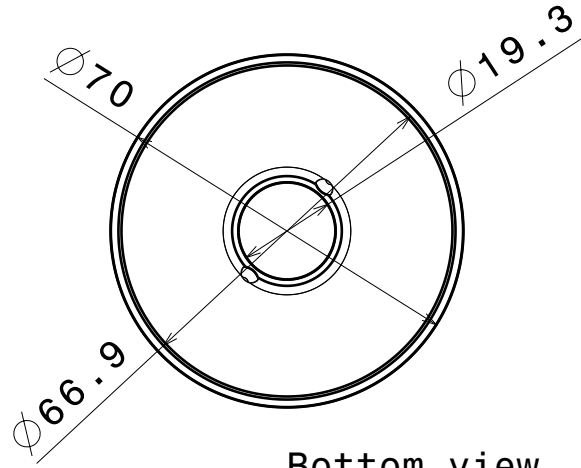

Bottom view

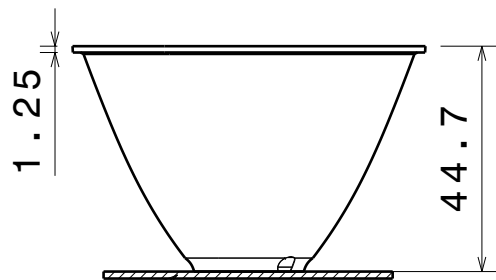

LED PCB

Front view

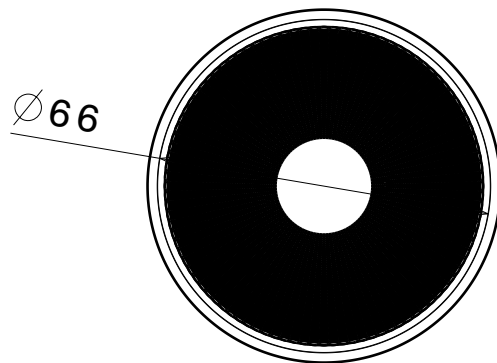

Top view

Material: PC with Metal coating and clear lacquer

This drawing is our property.  
It can't be reproduced  
or communicated without  
our written agreement.



Ledil Oy  
Salorankatu 10  
FIN-24100 SALO  
Finland

DRAWING TITLE

Datasheet Barbara Reflector series

DRAWN BY  
ah

DATE  
3.1.2012

CHECKED BY  
sn

DATE  
3.1.2012

SIZE  
A4

DRAWING NUMBER

REV  
2

DESIGNED BY  
ol

DATE  
23.06.2010

SCALE

2:3

WEIGHT (g)

SHEET

1/1

D

A

4

4

3

3

2

2

1

1