



STGP10NB60S

STGP10NB60SFP- STGB10NB60S

N-CHANNEL 10A - 600V - TO-220/TO-220FP/D²PAK
PowerMESH™ IGBT

Table 1: General Features

TYPE	V _{CES}	V _{CE(sat)} (Max) @25°C	I _C @100°C
STGP10NB60S	600 V	< 1.7 V	10 A
STGP10NB60SFP	600 V	< 1.7 V	10 A
STGB10NB60S	600 V	< 1.7 V	10 A

- HIGHT INPUT IMPEDANCE (VOLTAGE DRIVEN)
- VERY LOW ON-VOLTAGE DROP (V_{cesat})
- HIGH CURRENT CAPABILITY
- OFF LOSSES INCLUDE TAIL CURRENT

DESCRIPTION

Using the latest high voltage technology based on a patented strip layout, STMicroelectronics has designed an advanced family of IGBTs, the PowerMESH™ IGBTs, with outstanding performances. The suffix "S" identifies a family optimized achieve minimum on-voltage drop for low frequency applications (<1kHz).

APPLICATIONS

- LIGHT DIMMER
- STATIC RELAYS
- MOTOR CONTROL

Figure 1: Package

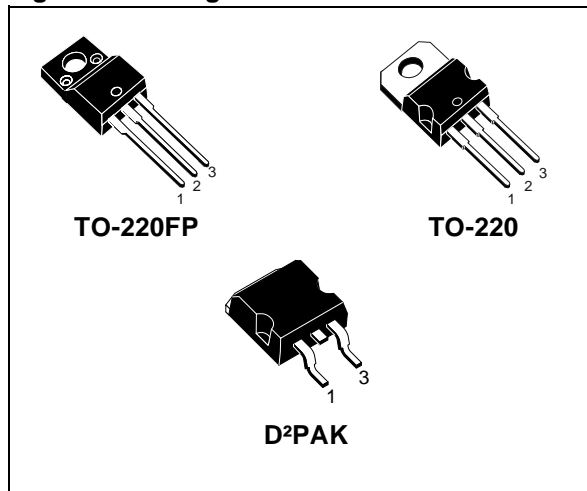

Figure 2: Internal Schematic Diagram

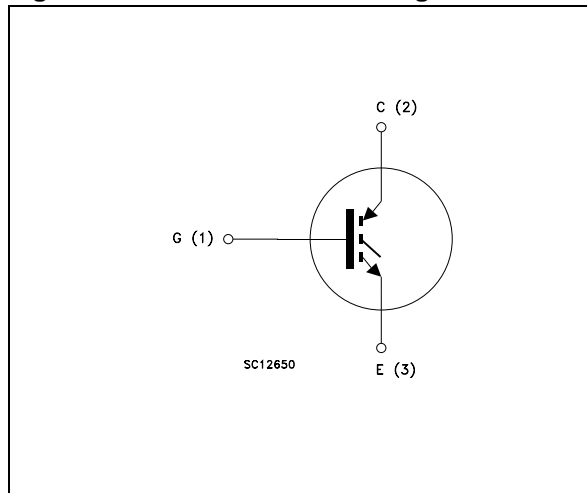

Table 2: Order Codes

SALES TYPE	MARKING	PACKAGE	PACKAGING
STGP10NB60S	GP10NB60S	TO-220	TUBE
STGP10NB60SFP	GP10NB60SFP	TO-220FP	TUBE
STGB10NB60ST4	GB10NB60S	D ² PAK	TAPE & REEL

Table 3: Absolute Maximum ratings

Symbol	Parameter	Value		Unit
		TO-220/D ² PAK	TO-220FP	
V _{CES}	Collector-Emitter Voltage (V _{GS} = 0)	600		V
V _{ECR}	Reverse Battery Protection	20		V
V _{GE}	Gate-Emitter Voltage	± 20		V
I _C	Collector Current (continuous) at 25°C	20		A
I _C	Collector Current (continuous) at 100°C	10		A
I _{CM} (1)	Collector Current (pulsed)	80		A
P _{TOT}	Total Dissipation at T _C = 25°C	80	25	W
	Derating Factor	0.64	0.20	W/°C
V _{ISO}	Insulation Withstand Voltage A.C.(t=1sec, T _C =25°C)	--	2500	V
T _{stg}	Storage Temperature	- 55 to 150		°C
T _j	Operating Junction Temperature			

(1)Pulse width limited by max. junction temperature.

Table 4: Thermal Data

			Min.	Typ.	Max.	Unit
R _{thj-case}	Thermal Resistance Junction-case	TO-220 D ² PAK			1.56	°C/W
		TO-220FP			5.0	°C/W
R _{thj-amb}	Thermal Resistance Junction-ambient				62.5	°C/W
T _L	Maximum Lead Temperature for Soldering Purpose (1.6 mm from case, for 10 sec.)			300		°C

ELECTRICAL CHARACTERISTICS (T_{CASE} =25°C UNLESS OTHERWISE SPECIFIED)
Table 5: Off

Symbol	Parameter	Test Conditions	Min.	Typ.	Max.	Unit
V _{BR(CES)}	Collectro-Emitter Breakdown Voltage	I _C = 250 μA, V _{GE} = 0	600			V
V _{BR(ECS)}	Emitter-Collector Breakdown Voltage	I _C = 1mA, V _{GE} = 0	20			V
I _{CES}	Collector cut-off (V _{GE} = 0)	V _{GE} = Max Rating, T _C =25°C V _{CE} = Max Rating, T _C =125°C			10 100	μA μA
I _{GES}	Gate-Emitter Leakage Current (V _{CE} = 0)	V _{GE} = ± 20 V , V _{CE} = 0			±100	nA

Table 6: On

Symbol	Parameter	Test Conditions	Min.	Typ.	Max.	Unit
V _{GE(th)}	Gate Threshold Voltage	V _{CE} = V _{GE} , I _C = 250 μA	2.5		5	V
V _{CE(SAT)}	Collector-Emitter Saturation Voltage	V _{GE} =15 V, I _C = 5 A,		1.15		V
		V _{GE} =15 V, I _C = 10 A,		1.35	1.7	V
		V _{GE} =15 V, I _C = 10 A, T _j = 125°C		1.25		V

ELECTRICAL CHARACTERISTICS (CONTINUED)

Table 7: Dynamic

Symbol	Parameter	Test Conditions	Min.	Typ.	Max.	Unit
g_{fs} (1)	Forward Transconductance	$V_{CE} = 25 \text{ V}$, $I_C = 10 \text{ A}$		7		S
C_{ies}	Input Capacitance	$V_{CE} = 25 \text{ V}$, $f = 1 \text{ MHz}$, $V_{GE} = 0$		610		pF
C_{oes}	Output Capacitance			65		pF
C_{res}	Reverse Transfer Capacitance			12		pF
Q_g	Total Gate Charge	$V_{CE} = 400 \text{ V}$, $I_C = 10 \text{ A}$, $V_{GE} = 15 \text{ V}$ (see Figure 20)		33		nC
I_{CL}	Latching Current	$V_{clamp} = 480 \text{ V}$, $T_j = 150^\circ\text{C}$ $R_G = 1 \text{ k}\Omega$	20			A

Table 8: Switching On

Symbol	Parameter	Test Conditions	Min.	Typ.	Max.	Unit
$t_{d(on)}$ t_r	Turn-on Delay Time Current Rise Time	$V_{CC} = 480 \text{ V}$, $I_C = 10 \text{ A}$ $R_G=1\text{K}\Omega$ $V_{GE} = 15 \text{ V}$ (see Figure 18)		0.7 0.46		μs μs
$(di/dt)_{on}$ E_{on} (1)	Turn-on Current Slope Turn-on Switching Losses	$V_{CC} = 480 \text{ V}$, $I_C = 10 \text{ A}$ $R_G=1\text{K}\Omega$ $V_{GE} = 15 \text{ V}$, $T_j = 125^\circ\text{C}$		8 0.6		$\text{A}/\mu\text{s}$ mJ

Table 9: Switching Off

Symbol	Parameter	Test Conditions	Min.	Typ.	Max.	Unit
t_c	Cross-Over Time	$V_{CC} = 480 \text{ V}$, $I_C = 10 \text{ A}$, $R_G = 10 \Omega$, $V_{GE} = 15 \text{ V}$ $T_J = 25^\circ\text{C}$ (see Figure 18)		2.2		μs
$t_r(V_{off})$	Off Voltage Rise Time			1.2		μs
t_f	Current Fall Time			1.2		μs
E_{off} (**)	Turn-off Switching Loss			5.0		mJ
t_c	Cross-Over Time	$V_{CC} = 480 \text{ V}$, $I_C = 10 \text{ A}$, $R_G = 10 \Omega$, $V_{GE} = 15 \text{ V}$ $T_J = 125^\circ\text{C}$ (see Figure 18)		3.8		μs
$t_r(V_{off})$	Off Voltage Rise Time			1.2		μs
t_f	Current Fall Time			1.9		μs
E_{off} (**)	Turn-off Switching Loss			8.0		mJ

(1) Pulse width limited by max. junction temperature.

(**) Losses Include Also the Tail (Jedec Standardization)

Figure 3: Output Characteristics

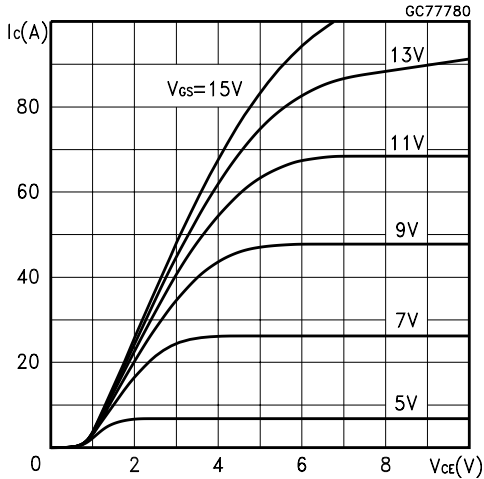

Figure 4: Transconductance

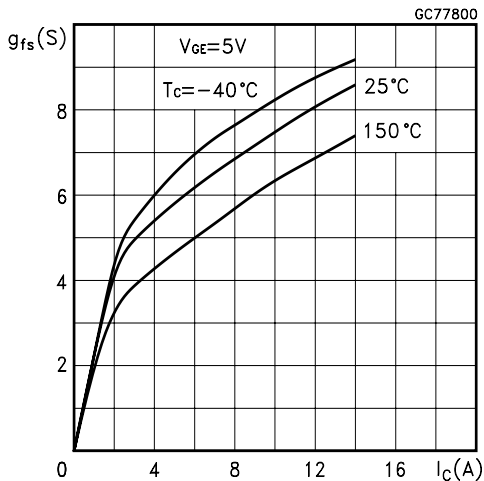

Figure 5: Collector-Emitter On Voltage vs Collector Current

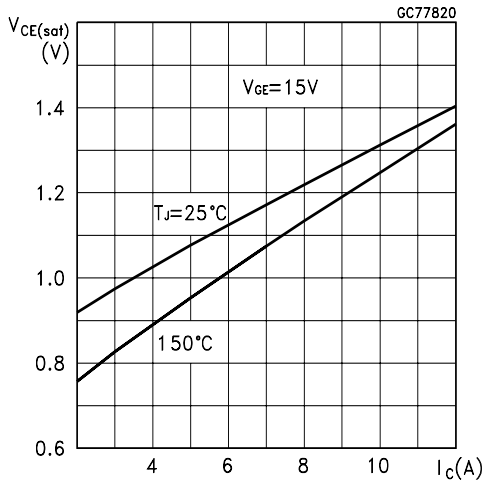

Figure 6: Transfer Characteristics

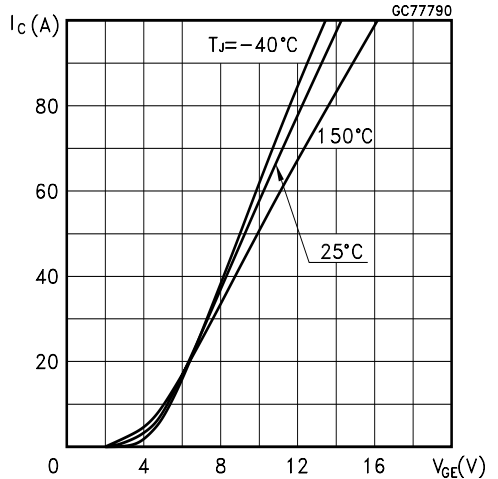

Figure 7: Collector-Emitter On Voltage vs Temperature

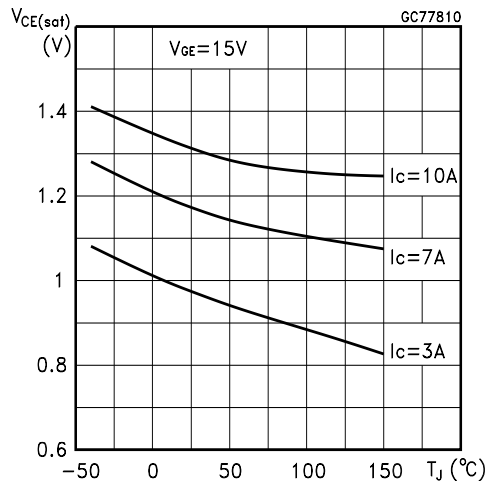

Figure 8: Gate Threshold vs Temperature

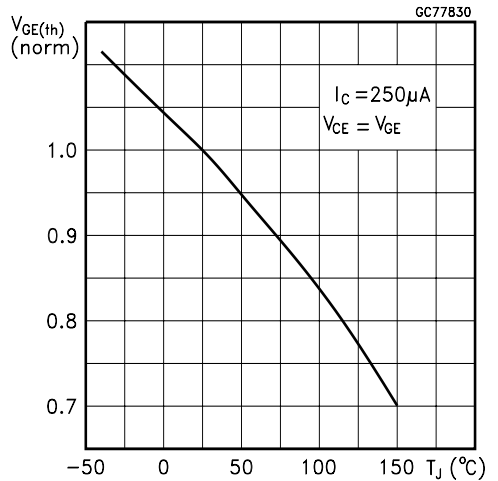

Figure 9: Capacitance Variations

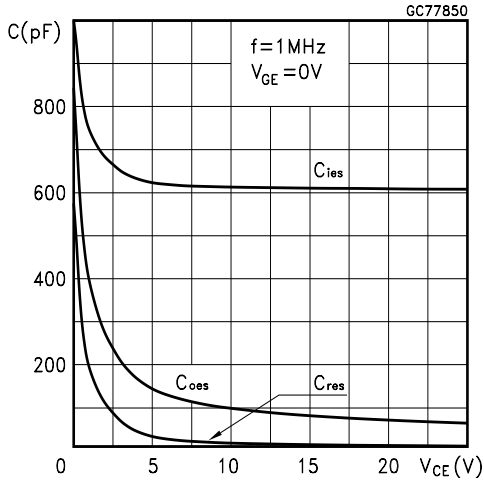

Figure 10: Off Losses vs Gate Resistance

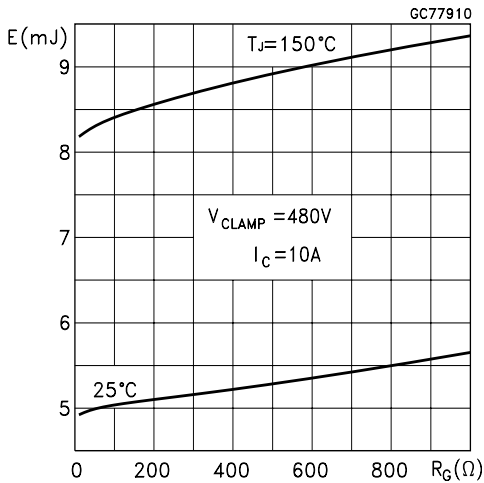

Figure 11: Normalized Breakdown Voltage vs Temperature

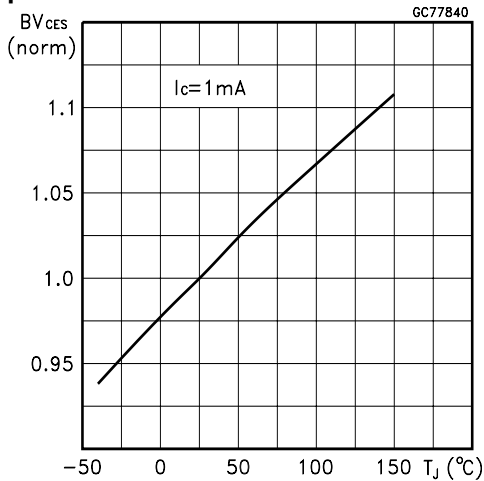

Figure 12: Gate Charge vs Gate-Emitter Voltage

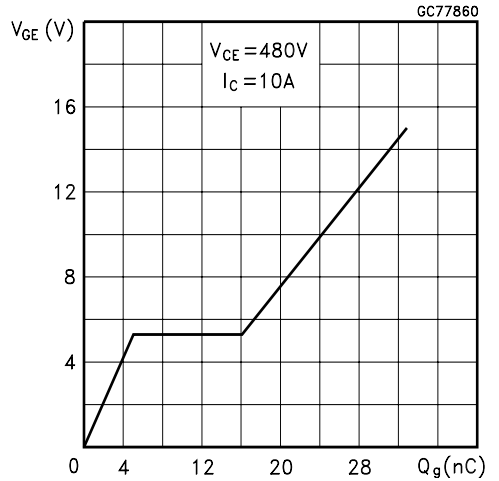

Figure 13: Off Losses vs Temperature

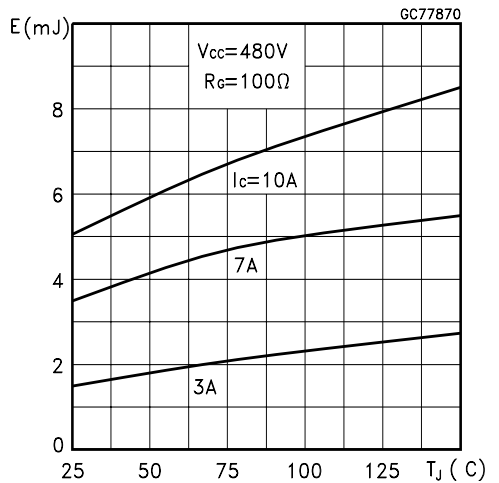

Figure 14: Off Losses vs Collector Current

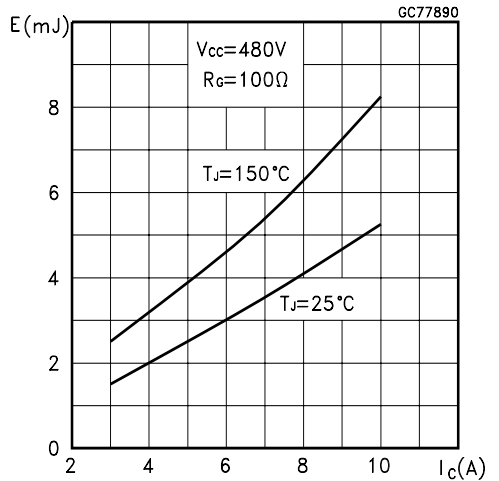

Figure 14: Off Losses vs Collector Current

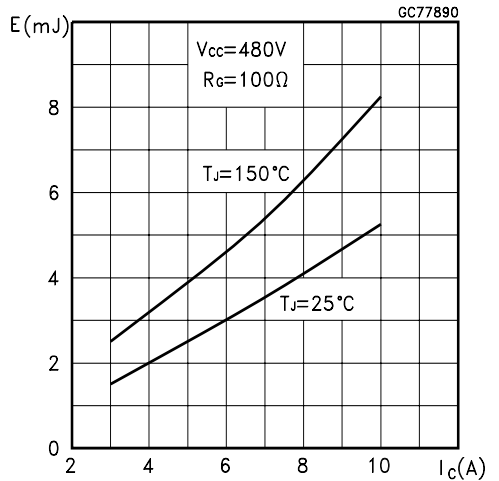

Figure 15: Thermal Impedance For TO-220/ D²PAK

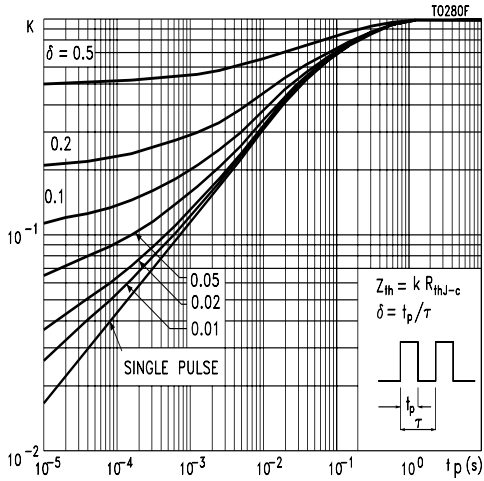

Figure 16: Turn-Off SOA

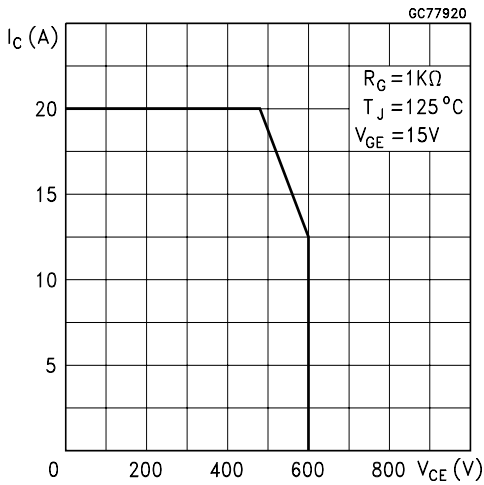

Figure 17: Thermal Impedance For TO-220FP

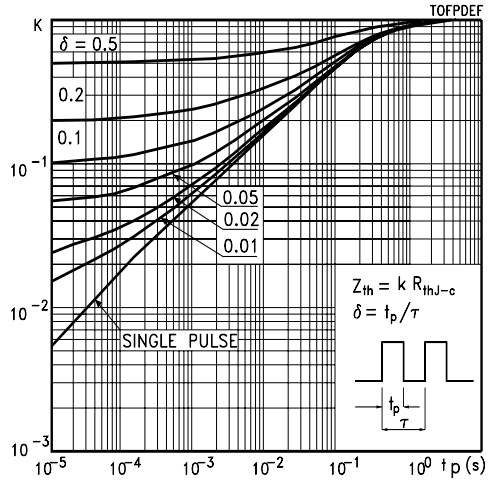

Figure 18: Test Circuit for Inductive Load Switching

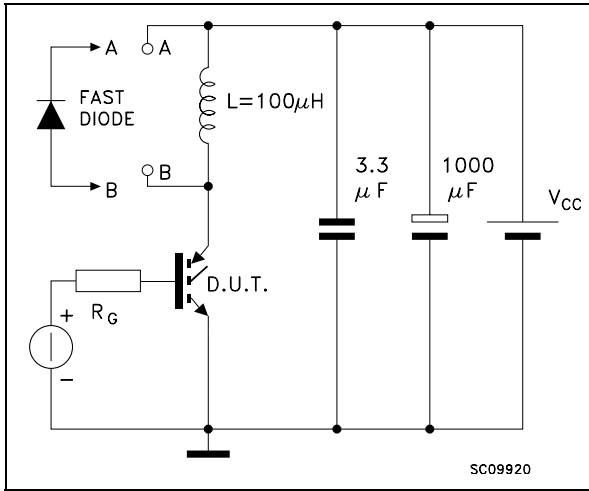

Figure 19: Switching Waveforms

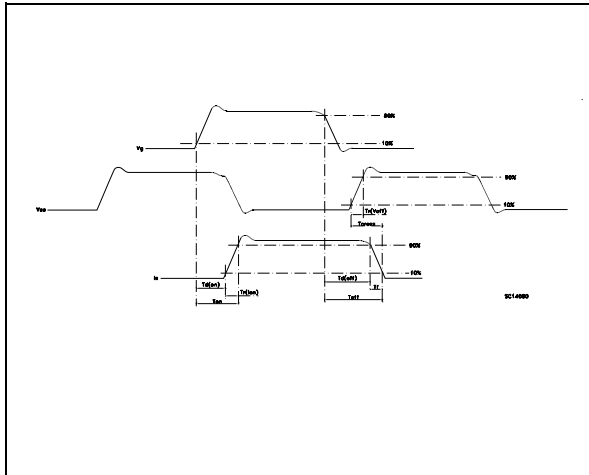
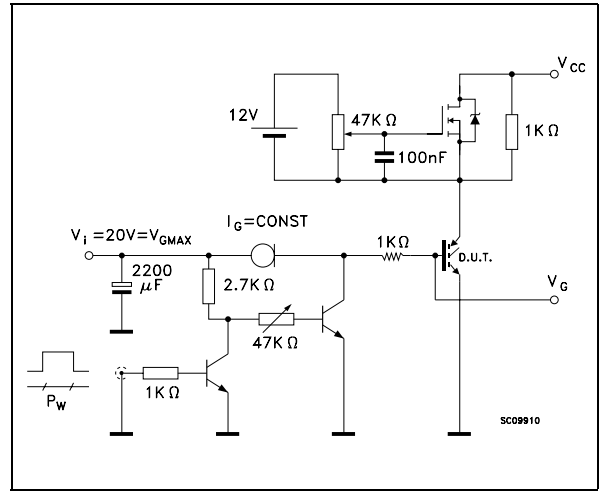
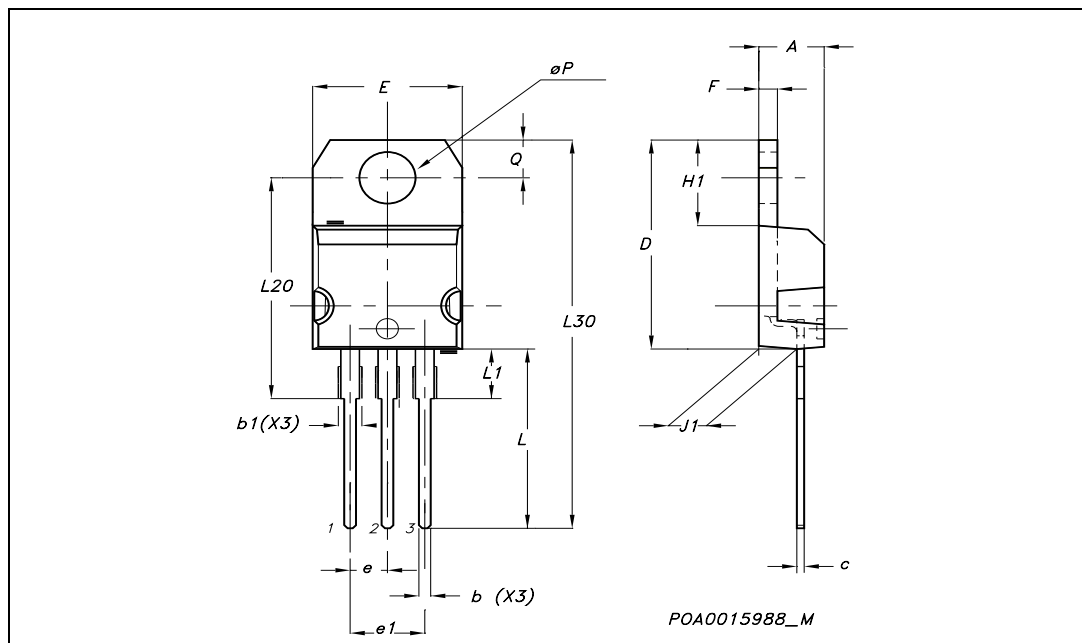

Figure 20: Gate Charge Test Circuit



TO-220 MECHANICAL DATA

DIM.	mm.			inch		
	MIN.	TYP	MAX.	MIN.	TYP.	MAX.
A	4.40		4.60	0.173		0.181
b	0.61		0.88	0.024		0.034
b1	1.15		1.70	0.045		0.066
c	0.49		0.70	0.019		0.027
D	15.25		15.75	0.60		0.620
E	10		10.40	0.393		0.409
e	2.40		2.70	0.094		0.106
e1	4.95		5.15	0.194		0.202
F	1.23		1.32	0.048		0.052
H1	6.20		6.60	0.244		0.256
J1	2.40		2.72	0.094		0.107
L	13		14	0.511		0.551
L1	3.50		3.93	0.137		0.154
L20		16.40			0.645	
L30		28.90			1.137	
øP	3.75		3.85	0.147		0.151
Q	2.65		2.95	0.104		0.116



TO-220FP MECHANICAL DATA

DIM.	mm.			inch		
	MIN.	TYP	MAX.	MIN.	TYP.	MAX.
A	4.4		4.6	0.173		0.181
B	2.5		2.7	0.098		0.106
D	2.5		2.75	0.098		0.108
E	0.45		0.7	0.017		0.027
F	0.75		1	0.030		0.039
F1	1.15		1.7	0.045		0.067
F2	1.15		1.7	0.045		0.067
G	4.95		5.2	0.195		0.204
G1	2.4		2.7	0.094		0.106
H	10		10.4	0.393		0.409
L2		16			0.630	
L3	28.6		30.6	1.126		1.204
L4	9.8		10.6	.0385		0.417
L5	2.9		3.6	0.114		0.141
L6	15.9		16.4	0.626		0.645
L7	9		9.3	0.354		0.366
∅	3		3.2	0.118		0.126

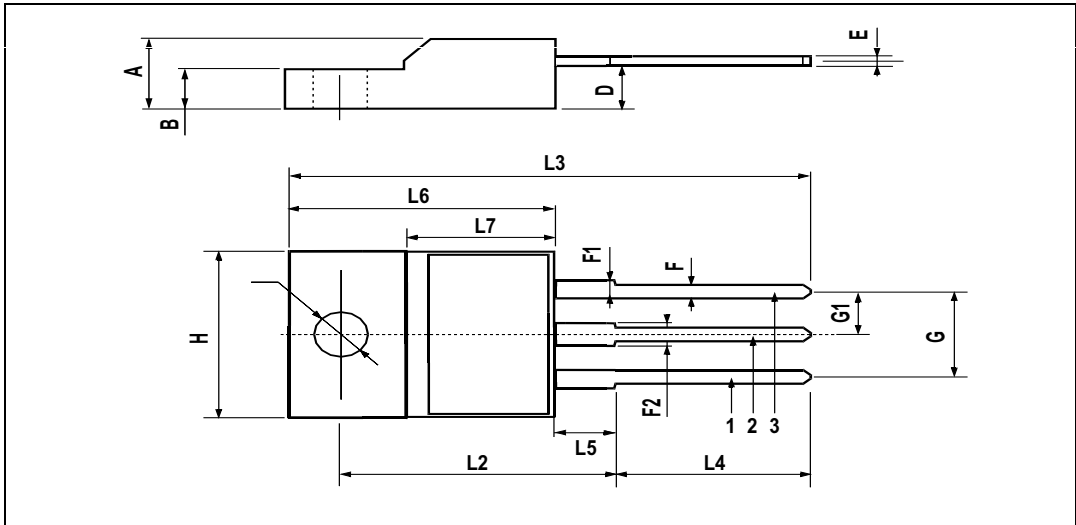

TO-263 (D²PAK) MECHANICAL DATA

DIM.	mm.			inch		
	MIN.	TYP	MAX.	MIN.	TYP.	MAX.
A	4.32		4.57	0.178		0.180
A1	0.00		0.25	0.00		0.009
b	0.71		0.91	0.028		0.350
b2	1.15		1.40	0.045		0.055
c	0.46		0.61	0.018		0.024
c2	1.22		1.40	0.048		0.055
D	8.89	9.02	9.40	0.350	0.355	0.370
D1	8.01			0.315		
E	10.04		10.28	0.395		0.404
e		2.54			0.010	
H	13.10		13.70	0.515		0.540
L	1.30		1.70	0.051		0.067
L1	1.15		1.39	0.045		0.054
L2	1.27		1.77	0.050		0.069
L4	2.70		3.10	0.106		0.122
V2	0°		8°	0°		8°

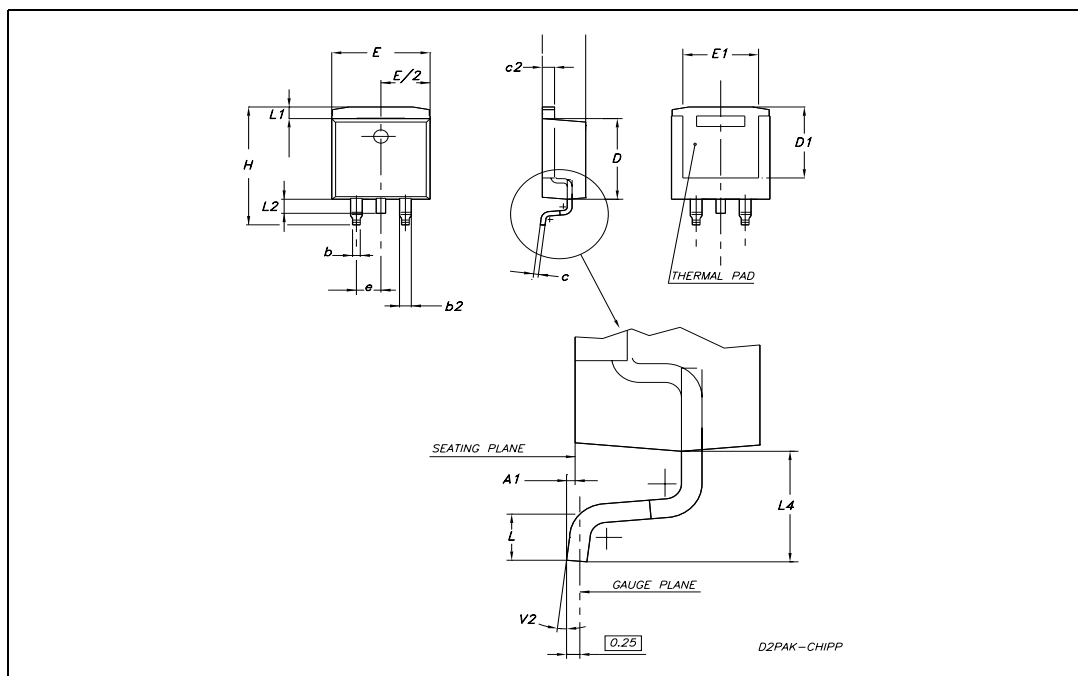

D²PAK FOOTPRINT

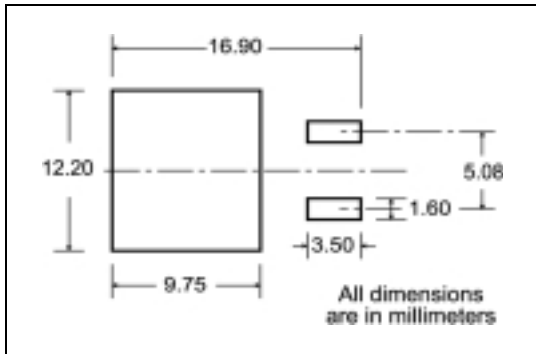

TUBE SHIPMENT (no suffix)*

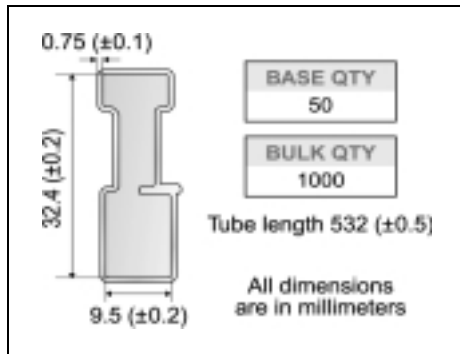

TAPE AND REEL SHIPMENT (suffix "T4")*

Diagram showing the tape mechanical data. It includes a top view of the tape with dimensions A, B, C, D, and G. A 40 mm min. access hole is shown at the slot location. The tape slot in the core for tape start is 2.5 mm min. width. The full radius is also indicated. A side view shows dimensions T, N, and G measured at the hub.

TAPE MECHANICAL DATA

DIM.	mm		inch	
	MIN.	MAX.	MIN.	MAX.
A0	10.5	10.7	0.413	0.421
B0	15.7	15.9	0.618	0.626
D	1.5	1.6	0.059	0.063
D1	1.59	1.61	0.062	0.063
E	1.65	1.85	0.065	0.073
F	11.4	11.6	0.449	0.456
K0	4.8	5.0	0.189	0.197
P0	3.9	4.1	0.153	0.161
P1	11.9	12.1	0.468	0.476
P2	1.9	2.1	0.075	0.082
R	50		1.574	
T	0.25	0.35	0.0098	0.0137
W	23.7	24.3	0.933	0.956

REEL MECHANICAL DATA

DIM.	mm		inch	
	MIN.	MAX.	MIN.	MAX.
A		330		12.992
B	1.5		0.059	
C	12.8	13.2	0.504	0.520
D	20.2		0.795	
G	24.4	26.4	0.960	1.039
N	100		3.937	
T		30.4		1.197

BASE QTY	BULK QTY
1000	1000

Diagram showing the reel mechanical data. It includes a top view of the reel with dimensions A, B, C, D, E, F, G, H, I, J, K, L, M, N, O, P, Q, R, S, T, U, V, W, X, Y, Z. The top cover tape is shown with dimensions A, B, C, D, E, F, G, H, I, J, K, L, M, N, O, P, Q, R, S, T, U, V, W, X, Y, Z. The center line of the cavity is shown. The user direction of feed is indicated. The feed direction is also indicated. The bending radius is shown as R min. A note indicates 10 pitches cumulative tolerance on tape ± 0.2 mm.

* on sales type

Table 10: Revision History

Date	Revision	Description of Changes
10-Nov-2004	1	First release
28-Feb-2005	2	Some values changed in table 6

Information furnished is believed to be accurate and reliable. However, STMicroelectronics assumes no responsibility for the consequences of use of such information nor for any infringement of patents or other rights of third parties which may result from its use. No license is granted by implication or otherwise under any patent or patent rights of STMicroelectronics. Specifications mentioned in this publication are subject to change without notice. This publication supersedes and replaces all information previously supplied. STMicroelectronics products are not authorized for use as critical components in life support devices or systems without express written approval of STMicroelectronics.

The ST logo is a registered trademark of STMicroelectronics

All other names are the property of their respective owners

© 2005 STMicroelectronics - All Rights Reserved

STMicroelectronics group of companies

Australia - Belgium - Brazil - Canada - China - Czech Republic - Finland - France - Germany - Hong Kong - India - Israel - Italy - Japan - Malaysia - Malta - Morocco - Singapore - Spain - Sweden - Switzerland - United Kingdom - United States of America