

**Photoelectric sensor**  
**Opposed mode sensor (laser emitter)**  
**M126E2LDQ**

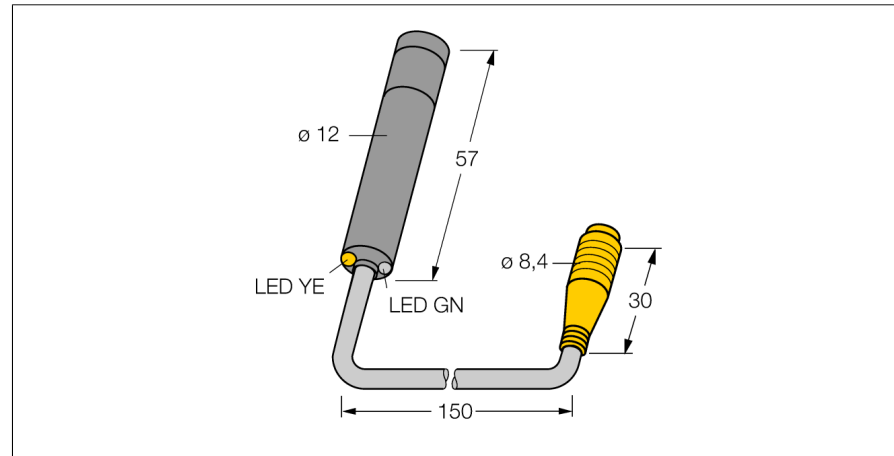

- Cable with male end, 4-pin, PVC, 150 mm, 8 mm
- Protection class IP67
- Aluminium housing
- LED all-round visible
- Laser class 2
- Operating voltage: 10...30 VDC

**Wiring Diagram**

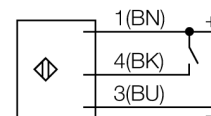

<b>Type code</b>	M126E2LDQ
Ident no.	3053801
<b>Operating mode</b>	opposed mode sensor (emitter)
Light type	red
Wavelength	650 nm
Laser class	▲ 2
Beam diameter	3 mm
Ambient temperature	0...+40°C
<b>Operating voltage</b>	10... 30VDC
No-load current I <sub>0</sub>	≤ 30 mA
Reverse polarity protection	yes
Readiness delay	≤ 30 ms
<b>Construction</b>	smooth barrel, M12
Dimensions	57mm mm
Housing diameter	12 mm
Housing material	Metal, AL, black
Lens	plastic, acrylic
Connection	cable with connector, PVC, Ø 8 mm
Cable length	0.15 m
Protection class	IP67
<b>Power-on indication</b>	LED green
Display release	LED, yellow

**Functional principle**

Opposed mode sensors consist of an emitter and receiver. They are installed opposite each other so that the light from the emitter is aimed directly at the receiver. When an object interrupts or weakens the light beam, the sensor switches. Opposed mode sensors are the most reliable photoelectric sensors for detection of opaque targets. An excellent contrast between light and dark conditions and an extremely high excess gain are typical of this sensing mode, thus allowing operation over larger distances and under difficult conditions.