

⚠ Safety notes

This product should be installed in line with installation rules, preferably by a qualified electrician. Incorrect installation and use can lead to risk of electric shock or fire. Before carrying out the installation read the instructions and take account of the product's specific mounting location. Do not open up, dismantle, alter or modify the device except where specifically required to do so by the instructions. All Legrand products must be opened and repaired exclusively by personnel trained and approved by Legrand. Any unauthorised opening or repair completely cancels all liabilities and the rights to replacement and guarantees. Use only Legrand brand accessories.

The device contains a LiMnO₂ primary cell. When the product reaches the end of its life, this cell must be correctly removed and disposed of in accordance with national legislation and the requirements of environmental protection.

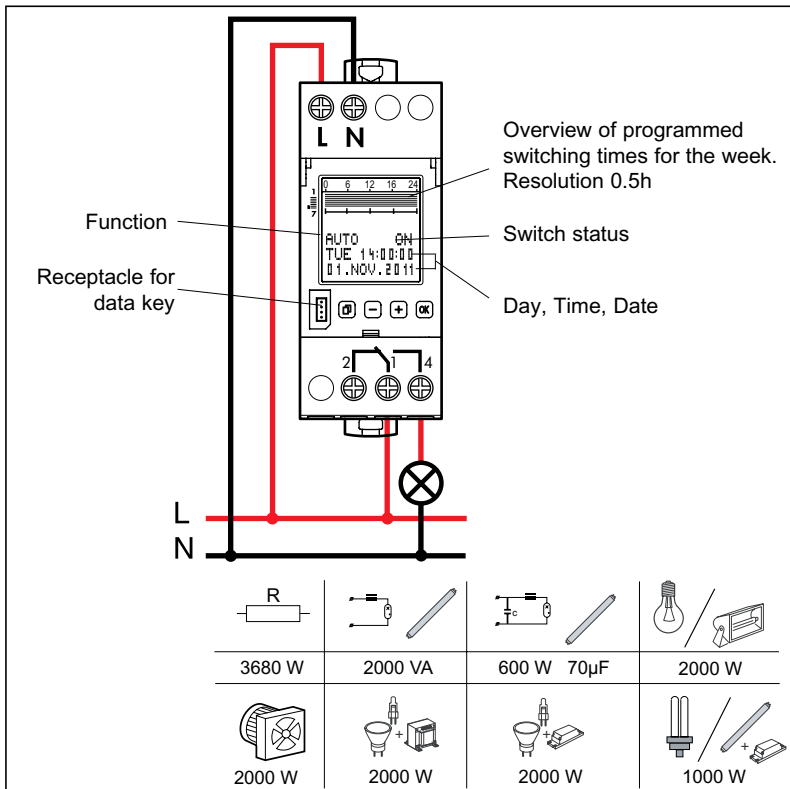

Operating principle: Typ 1.B. S. T.
IEC/EN 60730-1, IEC/EN 60730-2-7
Operation in a normal environment
Montage: in distribution panel, Degree of contamination: 2
Switch output, potential-free
Rated impulse voltage: 4 kV

General information

- **Start-up:** after applying the supply voltage, the time switch starts automatically with the last selected function. The relay position is set by the current program.
- **Battery backup**
 - Backlighting not active
 - Data key READ/WRITE only via the menu

- Select menu, back to main menu, Hold down > 1s = operating display
- Confirm selection or load parameters
- Select menu options or set parameters

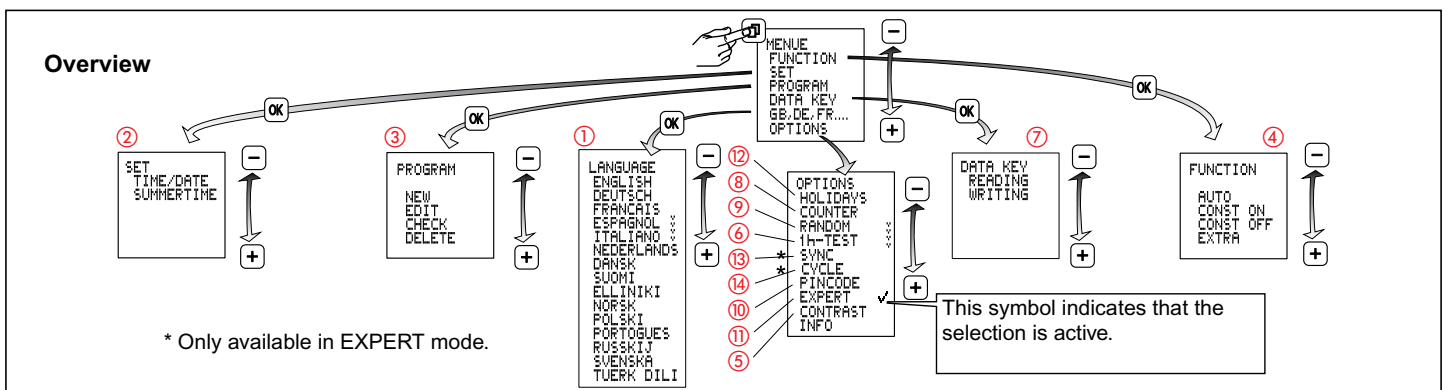

Technical data

	4126 31 047 61	4126 32 6047 60	4126 33 047 63
Supply voltage:	230V 50/60Hz	120V 50/60Hz	24V AC/DC
Effective power consumption: Approx.	1 W		
Contact rating:	1 changeover contact 16A 250V~µ cos φ = 1		
Parallel compensation:	600W max. 70µF		
Accuracy:	~ 0,1 s / day		
Terminal capacity:	single strand 1,5...4 mm ²	multi strand 1,5...2,5 mm ²	
Programmes :	56		
Battery reserve:	5 years		
Storage ambient:	-20°C to +60°C		
Working ambient:	-20°C to +55°C		
IP:	20		

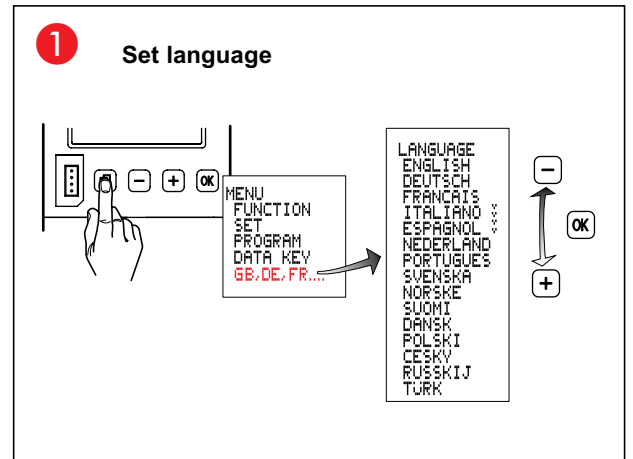

2 Set time/date, summertime/wintertime

Summertime: ± 1 hour

Europe: Factory set

SPECIAL: The switchover to/from

summertime can be freely programmed by entering a start date and end date and is then executed each year on the same day of the week, e.g. Sunday

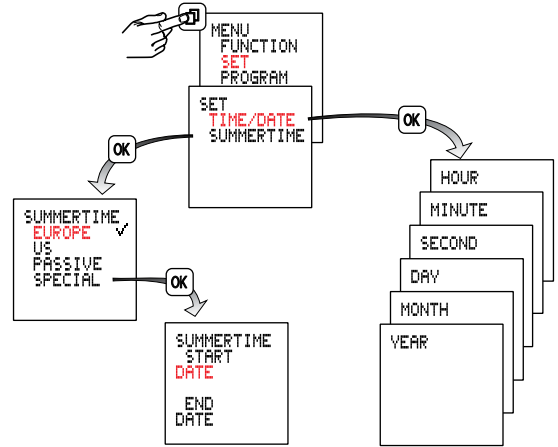

3 Programming

A program consists of an ON time, OFF time and associated on and off days.

Programs with predefined on/off days (Mon to Sun, Mon to Fri and Sat and Sun): for these programs, you only need to set the switching times. With the „INDIVIDUAL” option, you can allocate switching times to specific days of your choice.

The programs of a channel are combined with a logical OR.

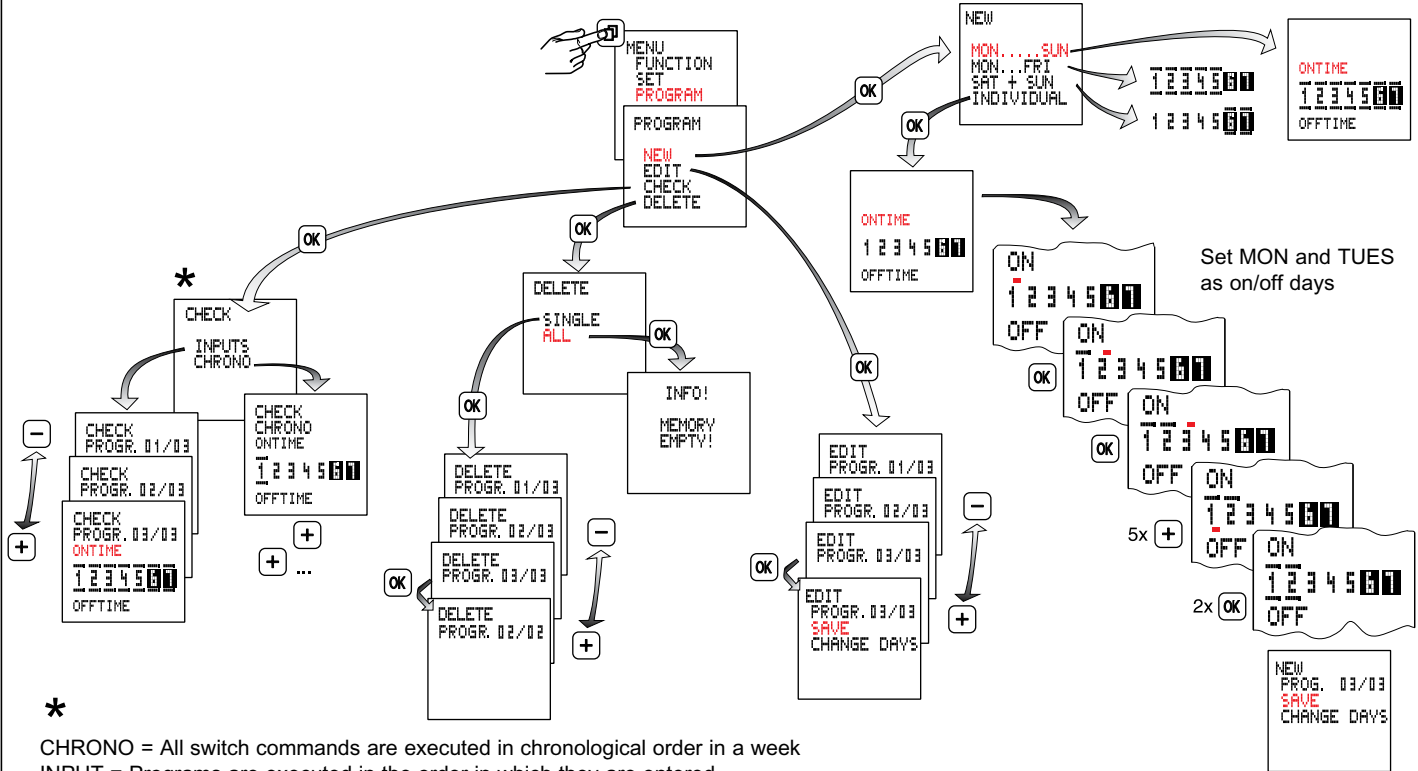

*

CHRONO = All switch commands are executed in chronological order in a week
INPUT = Programs are executed in the order in which they are entered

4 Modes

- **Auto** - Automatic operation
- **Constant ON**
- **Constant OFF**
- **Extra**

The switch status imposed by the program is inverted (manual override). With the next effective switch command, the time switch resumes control of on/off switching.

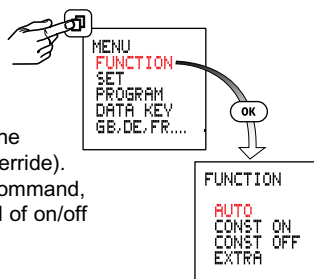

Reset

Warning!

The memory will be cleared, and all set data will be lost.

Hold down **OK** for more than 3 seconds and at the same time press and release **□** **-** **+**. The language, time, date, summertime/wintertime and switching times will have to be re-entered.

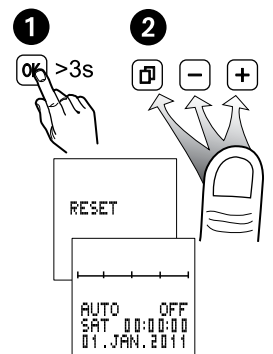

5 Contrast adjustment

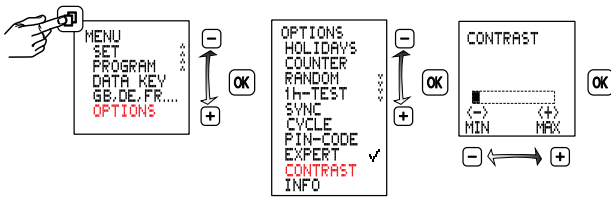

6 1 h-Test

When this function is activated, the output is switched on for one hour.

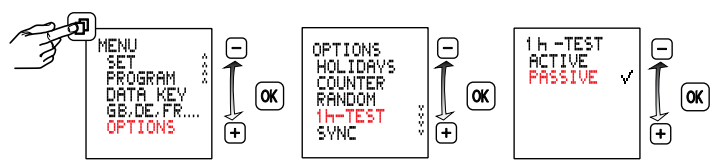

After one hour, the time switch returns automatically to the programmed mode.

7 Data key

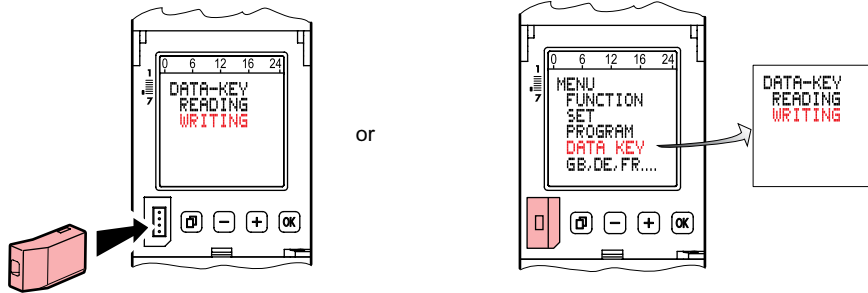

Load the programs of the time switch on to a data key (WRITE KEY)

Warning! all programs stored on the data key will be overwritten.

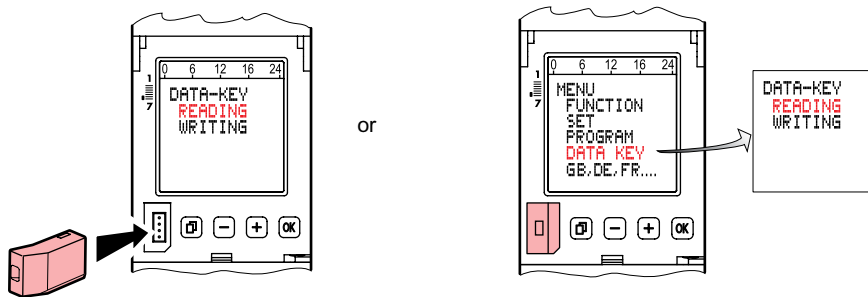

Load the programs from the data key to the time switch (READ KEY)

Warning! all programs programmed in the time switch will be overwritten.

8 Hour counter

Displays the total relay ON time, (0 to 65535 h) and the date of the last reset.

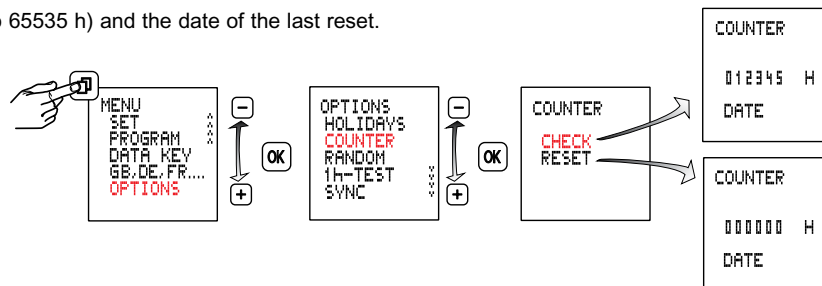

9 Random function

Function to simulate presence.

Function active: the programmed switching cycles are shifted at random within the range of ± 15 minutes.



14 Cycle function

Only available in EXPERT mode

For cyclical switch commands the switching on time is set by logical "OR" of programs of all types. A fixed cycle of ON and OFF time then operates within those limits. The cycle always starts with the ON time.

The cycle duration and the ON time within the cycle are the same length for all switching times. The cycle duration and the ON time can be set independently in one-second increments. If the switching time is shorter than the cycle duration, the cycle will be shortened accordingly. The ON time will remain unchanged. If the switching time is actually shorter than the ON time, the ON time will be shortened accordingly.

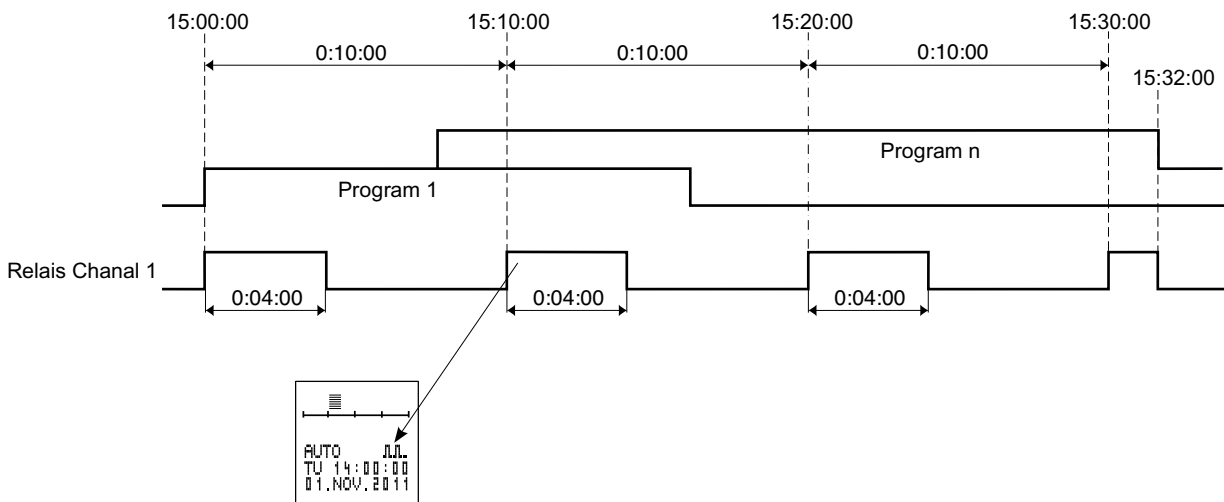
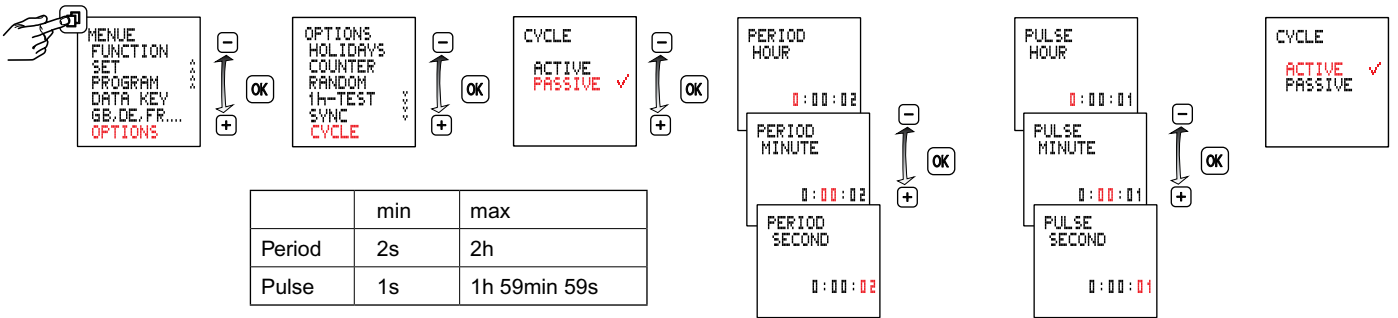

Switch off the device before dismantling the module. Do not switch on again until the module has been installed.
Always use a Li cell type battery (LiMnO₂) CR2477, 3V, high temperature type min +70°C.

