

Thermofit[®] Molded Parts Specification Control Drawing

Part Number : 222D921 thru 963
Description : Boot, 90°, With Lip

NOTES

- All dimensions are in $\frac{\text{inches}}{\text{millimeters}}$
- Dimensions appearing in table are as follows:
 - a - As Supplied
 - b - After Unrestricted Recovery
- Coating is optional. As supplied dimensions appearing in table are for uncoated parts. When coating is added, entry diameters will be reduced by .06 max.
- Molding ports are optional. When -00 modification number is specified molding ports will be located as shown.

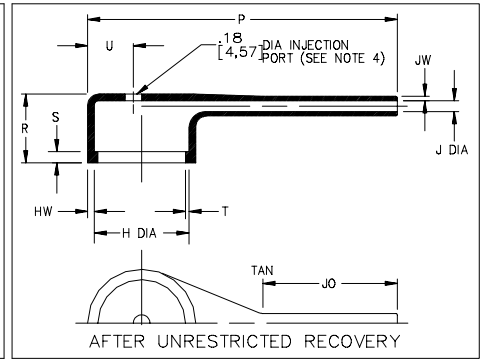
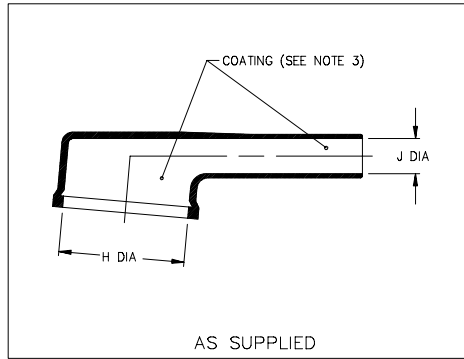

PART NUMBER	H		J			P ±10% b	R Ref b	S Ref b	T Ref b	U ±10% b	JO ±10% b	HW ±20% b	JW ±20% b
	Min a	Max b	Min -3-4-4-25 a	Min -4-12-100 a	Max b								
	[19,3]	[13,0]	[6,3]	[4,5]	[2,1]								
222D921	.76 [19,3]	.51 [13,0]	.25 [6,3]	.18 [4,5]	.08 [2,1]	1.75 [44,5]	.64 [16,3]	.12 [3,05]	.04 [1,02]	.22 [5,6]	.86 [21,8]	.06 [1,52]	.045 [1,14]
222D932	1.03 [26,1]	.75 [19,1]	.30 [7,6]	.22 [5,6]	.10 [2,6]	2.65 [67,3]	.71 [18,0]	.12 [3,05]	.04 [1,02]	.33 [8,4]	1.15 [29,2]	.07 [1,78]	.045 [1,14]
222D953	1.35 [34,2]	1.02 [26,0]	.38 [9,6]	.26 [6,6]	.12 [3,0]	3.20 [81,3]	.74 [18,8]	.12 [3,05]	.04 [1,02]	.45 [11,4]	1.39 [36,3]	.07 [1,78]	.045 [1,14]
222D963	1.72 [43,6]	1.34 [34,1]	.45 [11,4]	.31 [7,8]	.14 [3,6]	4.55 [115,6]	.84 [21,3]	.12 [3,05]	.065 [1,65]	.61 [15,5]	1.85 [47,0]	.07 [1,78]	.045 [1,14]

If this document is printed it becomes uncontrolled.
Check with the web for latest revision.

Raychem

RAYCHEM CORPORATION
300 CONSTITUTION DRIVE
MENLO PARK, CALIFORNIA 94025

Revision : H
Date : 2/16/95

Part Number : 222D921 thru 963
Description : Boot, 90°, With Lip

Thermofit[®] Molded Parts Specification Control Drawing

Part Number : 222D921 thru 963
Description : Boot, 90°, With Lip

MATERIAL DASH NO.	MATERIAL DESCRIPTION	RT SPEC	COATING SLASH NO.	COATING S NO.	COATING DESCRIPTION
-3	Polyolefin, Semi-rigid	RT-301	/42;/86;/87	S-1017;S-1048;S-1052	Adhesive
-4	Polyolefin, Flexible	RT-1304	/42;/86;/87	S-1017;S-1048;S-1052	Adhesive
-6	Silicone	RT-602	N/A		
-8	Polyolefin, Space	RT-1308	N/A		
-12	*VITON, Flexible	RT-1312	N/A		
-25	Elastomer, Fluid Resistant	RT-1325	/86	S-1048	Adhesive
-100	Polyolefin, Semi-flexible ZEROHAL™	RT-1323	/86;/184	S-1048;S-1030	Adhesive

*VITON is a Registered Trademark of Dupont

ORDERING INFORMATION

Base part number 222D9XX -XX -XX /XXX

Material dash number (See Compatibility Chart)

Modification number (If necessary, see front of scd binder for a complete list)

Adhesive slash number (If necessary, see Compatibility Chart)

THIS DRAWING IS SUBJECT TO CHANGE WITHOUT NOTICE; CONSULT YOUR
NEAREST FIELD REPRESENTATIVE FOR CURRENT REVISION

Raychem

RAYCHEM CORPORATION
300 CONSTITUTION DRIVE
MENLO PARK, CALIFORNIA 94025

If this document is printed it becomes uncontrolled.
Check with the web for latest revision.

Revision : H
Date : 2/16/95

Part Number : 222D921 thru 963
Description : Boot, 90°, With lip

CAD FILE MP95076