

## Instruction Manual

---

# HI 9142

## Portable Waterproof Dissolved Oxygen Meter

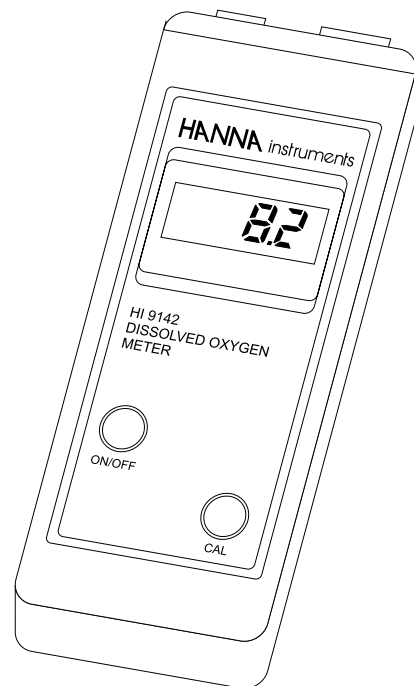

---

This instrument is in Compliance with the CE Directives

 **HANNA**  
instruments  
<http://www.hannainst.com>



Dear Customer,

Thank you for choosing a Hanna Instruments Product.

Please read this instruction manual carefully before using the instrument.

This manual will provide you with all the necessary information for the correct use of the instrument, as well as a precise idea of its versatility in a wide range of applications.

This instrument is in compliance with CE directives EN 50081-1 and 50082-1.

## TABLE OF CONTENTS

Preliminary Examination .....	1
General Description .....	1
Functional Description Probe .....	2
Functional Description Meter .....	3
Specifications .....	4
Initial Probe Preparation .....	5
Calibration Procedure .....	6
Taking Measurements .....	8
Altitude and Salinity Compensation .....	9
Probe & Membrane Maintenance .....	11
Battery Replacement .....	13
Accessories .....	14
Warranty .....	15
Other Products from Hanna .....	16
CE Declaration of Conformity .....	17

 **HANNA** *ISO 9000 Certified*  
instruments *Company since 1992*

## PRELIMINARY EXAMINATION

Remove the instrument from the packing material and examine it to make sure that no damage has occurred during shipping. If there is any damage, notify your Dealer.

In addition to this manual you should find the following items:

- D.O. meter
- 4 x 1.5V AA batteries
- DO Probe (HI 76407/4)
- Membrane cap (HI 76407A)
- Protective cap
- 30 mL electrolyte solution (HI 7041S)
- Rugged carrying case

**Note:** Save all packing material until you are sure that the instrument functions correctly. All defective items must be returned to us in the original packaging with the supplied accessories.

## GENERAL DESCRIPTION

Hanna Instruments' **HI 9142** is a water-resistant, Dissolved Oxygen meter with Automatic Temperature Compensation. It has been developed for dissolved oxygen measurement in water and wastewater applications as well as other applications such as fish farming.

Dissolved oxygen is indicated in tenths of parts per million (ppm=mg/l) .

Four 1.5V AA batteries provide power and make the instrument completely portable.

The meter is housed in a rugged water-resistant case for maximum protection in the field as well as in the laboratory.

The dissolved oxygen probe has a membrane covering the polarographic sensors and a built-

in thermistor for temperature measurements and compensation. The thin permeable membrane isolates the sensor elements from the testing solution, but allows oxygen to enter. When a voltage is applied across the sensor, oxygen that has passed through the membrane reacts causing current to flow, allowing the determination of oxygen.

**FUNCTIONAL DESCRIPTION PROBE**

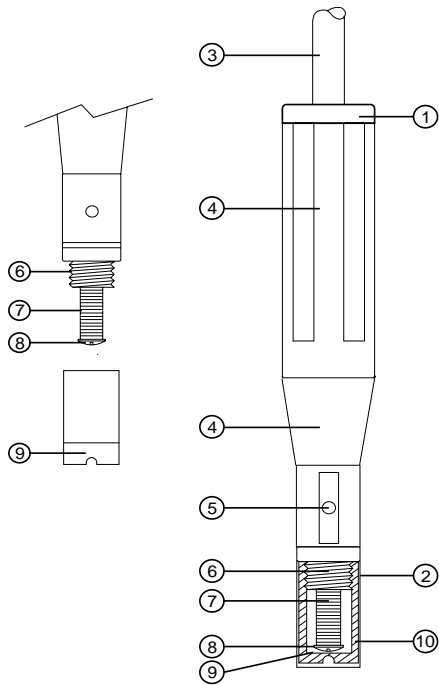

1. D.O. Probe
2. Protective Cap
3. Water-tight Shielded Cable
4. Polypropylene Probe Body
5. Temperature Sensor
6. O-Ring Seal
7. Silver Chloride Anode
8. Platinum Cathode (sensor)
9. Oxygen Permeable PTFE Membrane
10. Membrane Cap

**FUNCTIONAL DESCRIPTION**

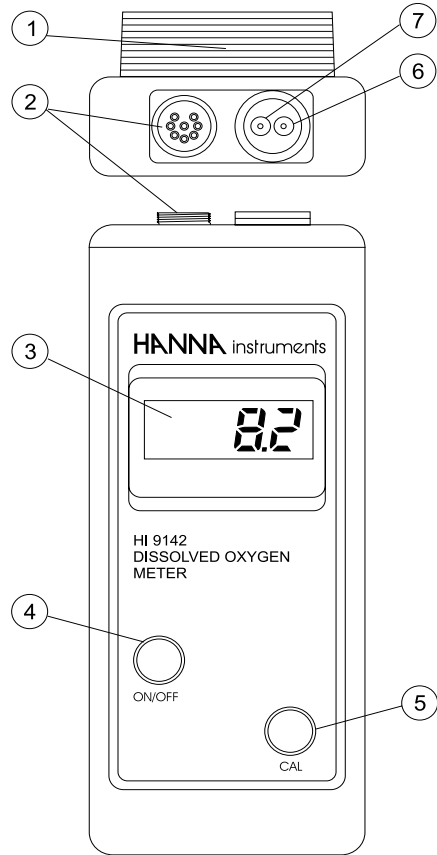

1. Battery Compartment
2. Probe Connector
3. Liquid Crystal Display
4. ON/OFF Button
5. Calibration Button
6. Slope Calibration Trimmer
7. Zero D.O. Calibration Trimmer

## SPECIFICATIONS

	<b>HI9142</b>
<b>Range</b>	0.0 to 19.9 mg/l
<b>Resolution</b>	0.1 mg/l
<b>Accuracy</b>	±1.5% Full Scale
<b>Typical EMC Deviation</b>	±0.8 mg/l with 4 m cable probe
<b>Calibration</b>	Manual on 2 points (zero and slope)
<b>Temperature Compensation</b>	Automatic from 0 to 30°C (32 to 86°F)
<b>Probe</b>	HI76407/4 polarographic with 4 m cable
<b>Battery Type Life</b>	4 x 1.5V AA 500 hours of continuous use
<b>Environment</b>	0 to 50°C (32 to 122°F); 100% RH
<b>Dimensions</b>	196x80x60 mm (7.7x3.1x2.4")
<b>Weight</b>	425 g (15 oz.); kit: 1.4 kg (3.1 lbs)

## INITIAL PROBE PREPARATION

### Probe Preparation

All probes shipped from Hanna Instrument are dry. To hydrate the probe and prepare it for use, connect it to the meter and proceed as follows.

- 1 Remove the red and black plastic cap. This cap is for shipping purposes and can be thrown away.
- 2 Wet the sensor by soaking the bottom 2½ cm (1") of the probe in electrolyte (**HI 7041S**) for 5 minutes.

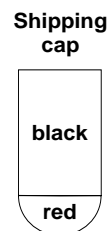

- 3 Rinse the membrane (**HI 76407A** supplied in the kit with the meter) with electrolyte while shaking it gently. Refill with clean electrolyte.

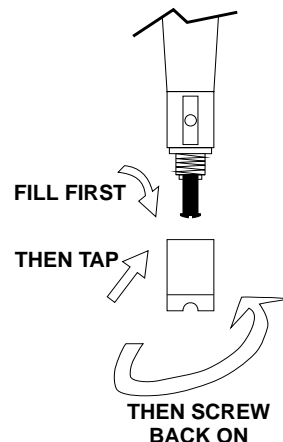

- 4 Gently tap the sides of the membrane with your finger tip to ensure that no air bubbles remain trapped. To avoid damaging the membrane, do not tap the membrane directly on the bottom.

- 5 Place rubber O-Ring properly inside the membrane cap.
- 6 With the sensor facing down, screw the cap clockwise. Some electrolyte will overflow.

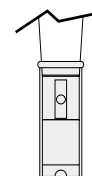

When not in use and during polarization, place the protective cap supplied in the kit with the meter.

## CALIBRATION PROCEDURE

### PROBE POLARIZATION

The probe is under polarization with a fixed voltage of approximately 800 mV.

Probe polarization is essential for stable measurements with the same recurring degree of accuracy.

With the probe properly polarized, oxygen is continually "consumed" by passing through the sensitive diaphragm and dissolving in the electrolyte solution contained in the probe.

If this operation is interrupted, the electrolyte solution continues to be enriched with oxygen until it reaches an equilibrium with the surrounding solution.

Whenever measurements are taken with a non-polarized probe, the oxygen level revealed is both that of the tested solution as well as that present in the electrolyte solution. This reading is incorrect

The calibration is very simple and fast.

- Make sure the probe is ready for measurements (see initial preparation at page 7), i.e. the membrane is filled with electrolyte and the probe is connected to the meter.

- Switch the meter on by pressing the ON/OFF key



- For an accurate calibration, it is recommended that you wait at least 15 minutes to ensure precise conditioning of the probe.

- Remove the protective cap from the D.O. probe.

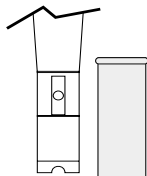

### Zero Calibration:

- Dip the probe into **HI 7040** zero oxygen solution and stir gently for 2-3 minutes.



- Allow 2 minutes for the LCD readout to stabilize.

- Adjust the zero D.O. calibration trimmer until the display reads "0.0".

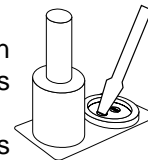

**Note** The zero calibration screw is located close to the probe connector.



### Slope Calibration:

It is suggested to perform the slope calibration in saturated air.

- Rinse the probe in a large amount of clean water to remove any residual zero oxygen solution.

- Dry the probe tip and allow a few minutes for the LCD readout to stabilize.

- Press and hold the CAL key.



- Adjust the slope trimmer on the top of the meter to read "100%" on the LCD (while still holding the CAL button).

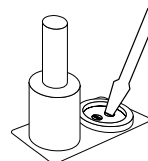

**Note** The slope calibration screw is located farthest from the probe connection.

- Release the CAL key and the LCD will display the value in ppm of oxygen.

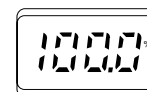

The **zero calibration** of the **HI 9142** is very stable, therefore this procedure needs only to be performed **whenever the probe is replaced**.

However, because the **slope calibration** is more critical, **it is recommended to perform this procedure every week**.

**TAKING MEASUREMENTS**

Make sure the meter has been calibrated and the protective cap has been removed. Immerse the tip of the probe in the sample to be tested.



Make sure the temperature sensor is also immersed.

For accurate dissolved oxygen measurements a water movement of 0.3 m/sec is required at a minimum. This is to ensure that the oxygen-depleted membrane surface is constantly replenished. A moving stream will provide adequate circulation. To quickly check if the water speed is sufficient, wait for the reading to stabilize and then move the D.O. probe. If the reading is still stable, the measurement conditions are right, while if the reading increases the water movement is not adequate.

During field measurements, this condition may be met by manually agitating the probe. Accurate readings are not possible while the liquid is at rest.

During laboratory measurements, the use of a magnetic stirrer to ensure a certain velocity in the fluid is recommended. In this way, errors due to the diffusion of the oxygen present in the air in the solution are reduced to a minimum.

At all times, time necessary for thermal equilibrium to occur between the probe and the sample must be allowed (a few minutes for temperature difference of several degrees).

**ALTITUDE & SALINITY COMPENSATION**

If the sample contains salts or if you are performing the measurements at a different altitude than sea level, the readout values must be corrected, taking into account the lower degree of oxygen solubility.

**ALTITUDE COMPENSATION**

All the readouts are referred at sea level, thus the displayed measurements are higher than the actual values. In fact, altitude affects D.O. concentration decreasing its value. The following table reports the oxygen solubility at various temperatures and altitudes, based on sea level barometric pressure of 760 mm Hg.

°C	Altitude, Meters above Sea Level							°F
	0 m	300 m	600 m	900 m	1200 m	1500m	1800m	
0	14.6	14.1	13.6	13.2	12.7	12.3	11.8	32.0
2	13.8	13.3	12.9	12.4	12.0	11.6	11.2	35.6
4	13.1	12.7	12.2	11.9	11.4	11.0	10.6	39.2
6	12.4	12.0	11.6	11.2	10.8	10.4	10.1	42.8
8	11.8	11.4	11.0	10.6	10.3	9.9	9.6	46.4
10	11.3	10.9	10.5	10.2	9.8	9.5	9.2	50.0
12	10.8	10.4	10.1	9.7	9.4	9.1	8.8	53.6
14	10.3	9.9	9.6	9.3	9.0	8.7	8.3	57.2
16	9.9	9.7	9.2	8.9	8.6	8.3	8.0	60.8
18	9.5	9.2	8.7	8.6	8.3	8.0	7.7	64.4
20	9.1	8.8	8.5	8.2	7.9	7.7	7.4	68.0
22	8.7	8.4	8.1	7.8	7.7	7.3	7.1	71.6
24	8.4	8.1	7.8	7.5	7.3	7.1	6.8	75.2
26	8.1	7.8	7.5	7.3	7.0	6.8	6.6	78.8
28	7.8	7.5	7.3	7.0	6.8	6.6	6.3	82.4
30	7.5	7.2	7.0	6.8	6.5	6.3	6.1	86.0
32	7.3	7.1	6.8	6.6	6.4	6.1	5.9	89.6
34	7.1	6.9	6.6	6.4	6.2	6.0	5.8	93.2
36	6.8	6.6	6.3	6.1	5.9	5.7	5.5	96.8
38	6.6	6.4	6.2	5.9	5.7	5.6	5.4	100.4
40	6.4	6.2	6.0	5.8	5.6	5.4	5.2	104.4

This gives an idea of the error that can be introduced at different altitudes and allows you to calculate the quantity to be subtracted to correct your reading.

### **SALINITY COMPENSATION**

The table below shows the influence of salt in the measurement of oxygen.

In **HI 9142** all the readouts are referred to 0 g/l of salinity value. In fact, salinity affects D.O. concentration decreasing its value.

For your reference the table below reports the oxygen solubility at various temperatures and salinity. From the table you can calculate the quantity to be subtracted to correct your reading.

°C	Salinity (g/l) at Sea Level					°F
	0 g/l	10 g/l	20 g/l	30 g/l	35 g/l	
10	11.3	10.6	9.9	9.3	9.0	50.0
12	10.8	10.1	9.5	8.9	8.6	53.6
14	10.3	9.7	9.1	8.6	8.3	57.2
16	9.9	9.3	8.7	8.2	8.0	60.8
18	9.5	8.9	8.4	7.9	7.6	64.4
20	9.1	8.5	8.0	7.6	7.4	68.0
22	8.7	8.2	7.8	7.3	7.1	71.6
24	8.4	7.9	7.5	7.1	6.9	75.2
26	8.1	7.6	7.2	6.8	6.6	78.8
28	7.8	7.4	7.0	6.6	6.4	82.4

### **PROBE & MEMBRANE MAINTENANCE**

The oxygen probe body is made of reinforced plastic for maximum durability.

A thermistor temperature sensor provides temperature measurements of the sample tested. It is always recommended that the protective cap be kept on the probe when the probe is not in use to provide protection against damage and dirt.

**To replace the membrane** or refill with electrolyte, proceed as follows:

- Remove the protective cap by gently twisting and pulling it off the body of the probe (see fig. 1).
- Unscrew the membrane by turning it counter-clock-wise with the other hand (see fig. 2)
- Wet the sensor by soaking the bottom 2½ cm (1") of the probe in electrolyte (**HI 7041S**) for 5 minutes.
- Rinse the new membrane (**HI 76407A**) supplied with the meter with electrolyte while shaking it gently. Refill with clean electrolyte.
- Gently tap the sides of the membrane with your finger tip to ensure that no air bubbles remain trapped. Do not directly tap the bottom with your finger as this will damage the membrane.

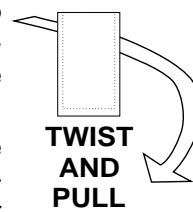

**TWIST AND PULL**

fig. 1

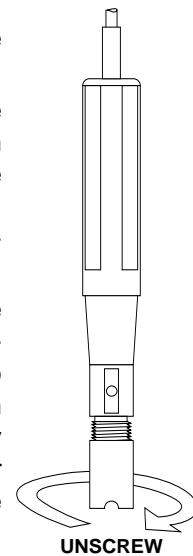

**UNSCREW**

fig. 2

- Make sure that the rubber O-ring is seated properly inside the membrane cap.
- With the sensor facing down, screw the membrane cap clock-wise. Some electrolyte will overflow.

The Platinum cathode (#8 in the Functional Description at page 4) should always be bright and untarnished. If it is tarnished or stained, which could be due to contact with certain gases or extended use with a loose or damaged membrane, the cathode should be cleaned. You can use a clean lint-free cardboard or cloth. Rub the cathode very gently side to side 4-5 times. This will be enough to polish and remove any stains without damaging the platinum tip. Afterwards, rinse the probe with deionized or distilled water and install a new membrane cap using fresh electrolyte and follow the steps above. Recalibrate the instrument.

**Important:** in order to have accurate and stable measurements, it is important that the surface of the membrane is in perfect condition. This semi-permeable membrane isolates the sensor elements from the environment but allows oxygen to enter. If any dirt is observed on the membrane, rinse carefully with distilled or deionized water. If any imperfections still exist, or any damage is evident (such as wrinkles or tears - holes), the membrane should be replaced. Make sure that the O-Ring is properly seated in the membrane cap.

## BATTERY REPLACEMENT

When the battery is rundown "V" is displayed on the Liquid Crystal Display to warn the user.

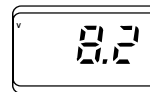

This is to inform the user that the display will be shut-off after about 4 hours of use to prevent erroneous measurements being taken due to low voltage.

Battery replacement must only take place in a non hazardous area using alkaline 1.5 V AA type batteries.

In order to replace run-down batteries, simply remove the two screws on the rear cover of the instrument and replace the four 1.5V AA batteries with new ones, paying attention to the correct polarity (refer to #1 in the Functional Description page 5).

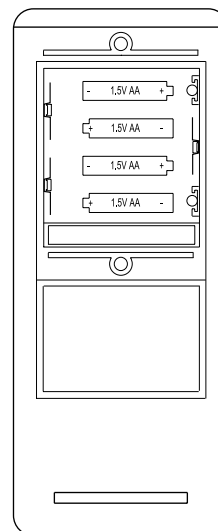

## ACCESSORIES

<b>HI 7040M</b>	Zero Oxygen calibration solution, 230 mL
<b>HI 7040L</b>	Zero Oxygen calibration solution, 460 mL
<b>HI 7041S</b>	Refilling Electrolyte solution, 30 mL
<b>HI 721308</b>	1.5V AA size alkaline battery (10pcs)
<b>HI 76407/10</b>	Spare probe with 10 meters (33') cable
<b>HI 76407/20</b>	Spare probe with 20 meters (66') cable
<b>HI 76407A/P</b>	Spare membrane (5pcs)
<b>MAN9142R1</b>	Instruction manual

## WARRANTY

All Hanna Instruments **meters are warranted for two years** against defects in workmanship and materials when used for their intended purpose and maintained according to the instructions. The **probes are warranted for a period of six months**.

Damages due to accidents, misuse, tampering or lack of prescribed maintenance are not covered. This warranty is limited to repair or replacement free of charge.

If service is required, contact the dealer from whom you purchased the instrument. If under warranty, report the model number, date of purchase, serial number and the nature of the failure. If the repair is not covered by the warranty, you will be notified of the charge for repair or replacement. If the instrument is to be returned to Hanna Instruments, obtain a Return Goods Authorization from the Customer Service Department first and then send it with shipment cost prepaid. When shipping any instrument, make sure it is properly packaged for complete protection.

To validate your warranty, fill out and return the enclosed warranty card within 14 days from the date of purchase.

*All rights are reserved. Reproduction in whole or in part is prohibited without the written consent of the copyright owner.*

Hanna Instruments reserves the right to modify the design, construction and appearance of its products without advance notice.

## OTHER PRODUCTS FROM HANNA



- CALIBRATION AND MAINTENANCE SOLUTIONS
- CHEMICAL TEST KITS
- CHLORINE METERS
- CONDUCTIVITY/TDS METERS
- DISSOLVED OXYGEN METERS
- HYGROMETERS
- ION SPECIFIC METERS (Colorimeters)
- MAGNETIC STIRRERS
- pH/Na/NaCl METERS
- pH/ORP/Na ELECTRODES
- PROBES (DO,  $\mu\text{S}/\text{cm}$ , RH, T, TDS)
- PUMPS
- REAGENTS
- SOFTWARE
- THERMOMETERS
- TITRATORS
- TRANSMITTERS
- TURBIDITY METERS
- Wide Range of Accessories

Most Hanna meters are available in the following formats:

- BENCH-TOP METERS
- POCKET-SIZED METERS
- PORTABLE METERS
- PRINTING/LOGGING METERS
- PROCESS METERS (Panel and Wall-mounted)
- WATERPROOF METERS
- METERS FOR FOOD INDUSTRY

For additional information, contact your dealer or the nearest Hanna Customer Service Center. You can also e-mail us at: [tech@hannainst.com](mailto:tech@hannainst.com).

## CE DECLARATION OF CONFORMITY

						
 DECLARATION OF CONFORMITY						
We Hanna Instruments Srl V.le delle industrie 12 35010 Ronchi di Villafranca (PD) ITALY						
herewith certify that the waterproof dissolved oxygen meter <b>HI 9142</b>						
has been tested and found to be in compliance with the following regulations:						
<table><tr><td><b>IEC 801-2</b></td><td>Electrostatic Discharge</td></tr><tr><td><b>IEC 801-3</b></td><td>RF Radiated</td></tr><tr><td><b>EN 55022</b></td><td>Radiated, Class B</td></tr></table>	<b>IEC 801-2</b>	Electrostatic Discharge	<b>IEC 801-3</b>	RF Radiated	<b>EN 55022</b>	Radiated, Class B
<b>IEC 801-2</b>	Electrostatic Discharge					
<b>IEC 801-3</b>	RF Radiated					
<b>EN 55022</b>	Radiated, Class B					
Date of Issue: <u>21-11-1995</u>	 D. Volpato - Engineering Manager On behalf of Hanna Instruments S.r.l.					

### Recommendations for Users

Before using this product, make sure that it is entirely suitable for the environment in which it is used.

Operation of this instrument in residential area could cause unacceptable interferences to radio and TV equipments, requiring the operator to take all necessary steps to correct interferences.

Any variation introduced by the user to the supplied equipment may degrade the instrument's EMC performance.

To avoid electrical shock, do not use this instrument when voltages at the measurement surface exceed 24VAC or 60 VDC.

To avoid damages or burns, do not perform any measurement in microwave ovens.

In particular cases the meter could turn off. In these cases it can be turned on by pressing the ON/OFF key.

PRINTED IN  
PORTUGAL

MAN9142R1  
12/95



<http://www.hannainst.com>