

A (10 : 1)

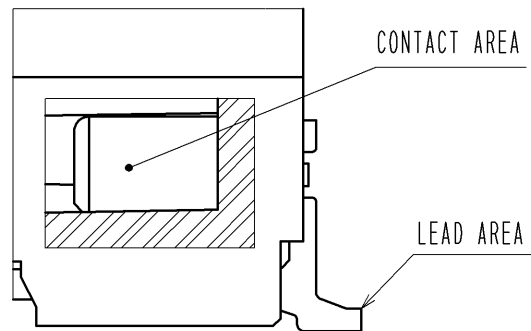

RECOMMENDED PCB LAYOUT (MOUNTING SURFACE SIDE) (FREE)

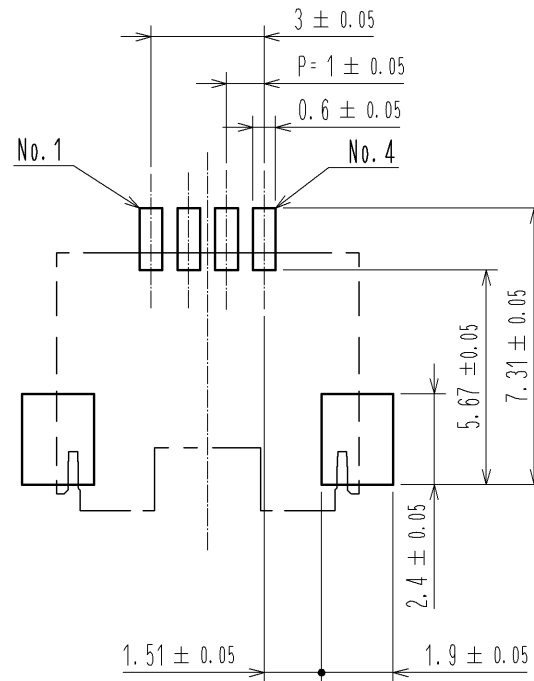

RECOMMENDED METAL MASK (FREE)

THICKNESS : 0.1mm
OPEN AREA RATIO:100%

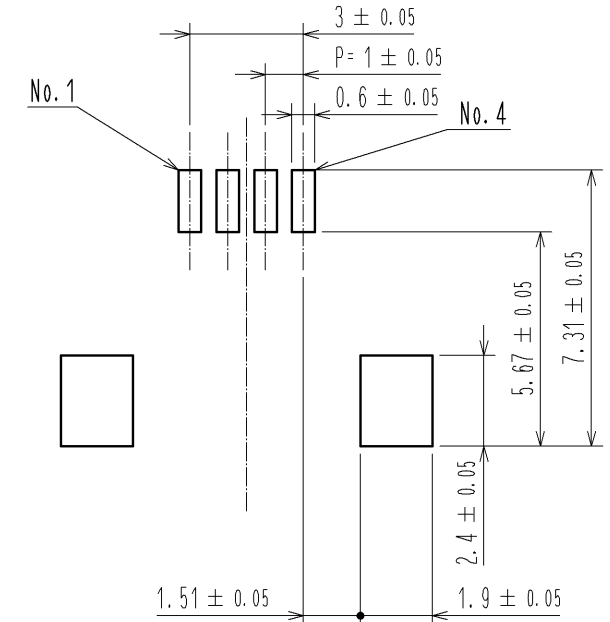

MATING FIGURE(5:1)

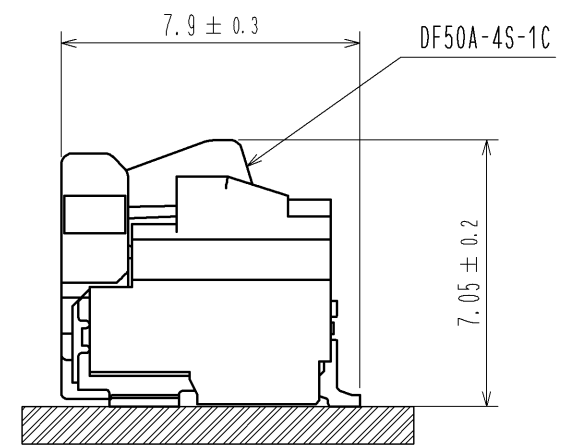
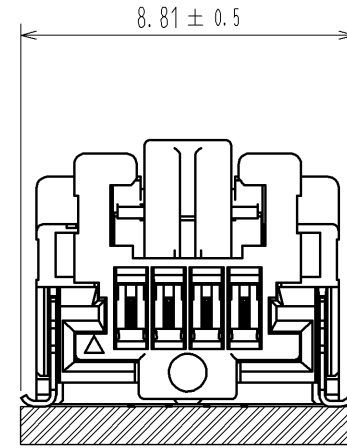

- NOTES 1. LEAD CO-PLANARITY SHALL BE 0.1mm MAX
- 2. PLEASE CONSULT HIROSE WHEN THE PRODUCT IS MONUTED TO FPC.

3	BRASS	CONTACT AREA : Sn PLATING 1μm MIN UNDER PLATING : Cu PLATING 0.3μm MIN			
2	BRASS	CONTACT AREA : Au PLATING 0.05μm MIN LEAD AREA : Au PLATING 0.05μm MIN UNDER PLATING : Ni PLATING 1μm MIN	6	PS	REEL , BLACK
1	LCP	BLACK , UL94V-0	5	POLYESTER	CLEAR
NO.	MATERIAL	FINISH , REMARKS	NO.	MATERIAL	CLEAR
UNITS mm		SCALE 5 : 1	COUNT	DESCRIPTION OF REVISIONS	DESIGNED
APPROVED : KI. AKIYAMA		12.06.19			
CHECED : HK. UMEHARA		12.06.19			
DESIGNED : ST. SATO		12.06.19			
DRAWN : ST. SATO		12.06.19			
DRAWING NO. EDC3-337106-01			PART NO. DF50A-4P-1H(51)		
CODE NO. CL665-1033-0-51			DATE		

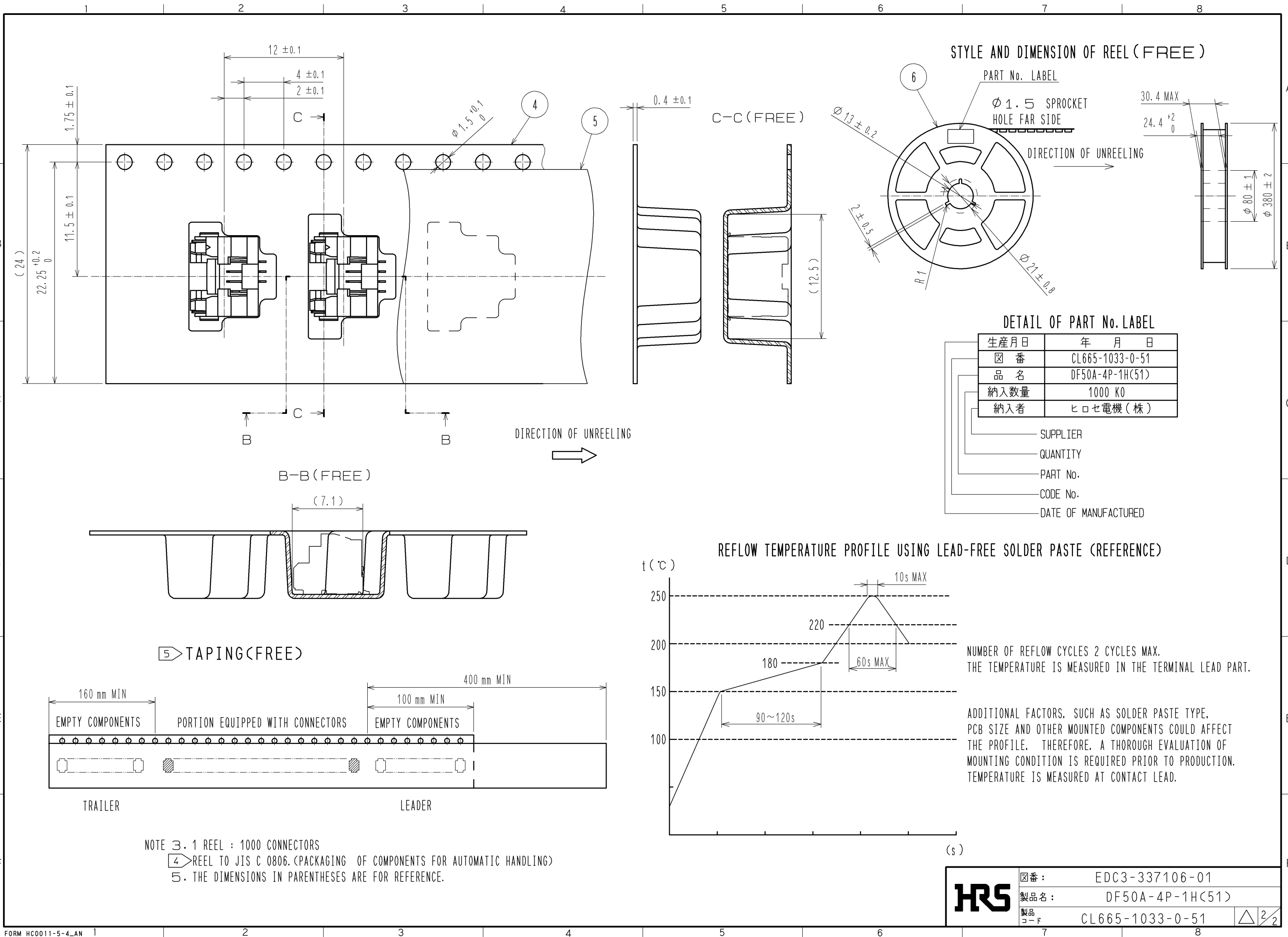

図番:	EDC3-337106-01
製品名:	DF50A-4P-1H(51)
製品コード:	CL665-1033-0-51