

**Signal processor**  
**MS96 for flow sensors**  
**MS96-11EX0-R/24VDC**

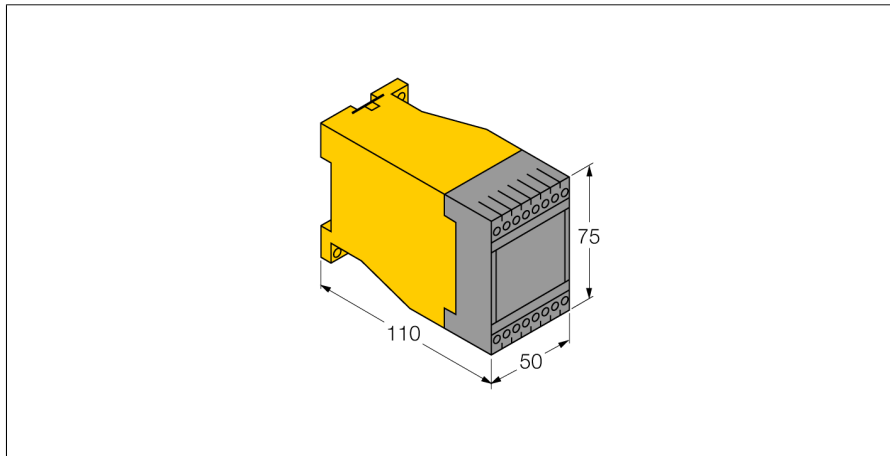

- ATEX category II (1) G, Ex Zone 0
- ATEX category II (1) D, Ex Zone 20
- single-channel signal processor MS96
- for connection of an intrinsically safe flow control sensor in zone 0
- adjustment via potentiometer
- 6 LEDs for display of the flow state
- intrinsically safe control circuit, [EExia] IIC
- switch-off delay adjustable in a range of 0...25 s
- wire-break monitoring
- 21...28 VDC
- Changeover contact, relay output

<b>Type code</b>	MS96-11EX0-R/24VDC
Ident no.	5231407
<b>Ambient temperature</b>	-20...60 °C
<b>Operating voltage</b>	21...28VDC
No-load current I <sub>0</sub>	≤ 125 mA
Output function	Relay output, changover contact
Device designation	Ⓢ II(1) G D [EEx ia] IIC
Protection type	II(1) G D [EEx ia] II C
Ex approval acc. to conformity certificate	TÜV 96 ATEX 1098
Protection class	IP20
Protection class (terminals/housing)	IP20 / IP40
<b>Design</b>	terminal chamber
Dimensions	110 x 50 x 75 mm
Housing material	polycarbonate/ABS
Connection	terminal chamber
<b>Indication: Drop below setpoint</b>	LED red
Indication: Setpoint reached	LED yellow
Indication: Setpoint exceeded	4 x LEDs green

**Wiring diagram**

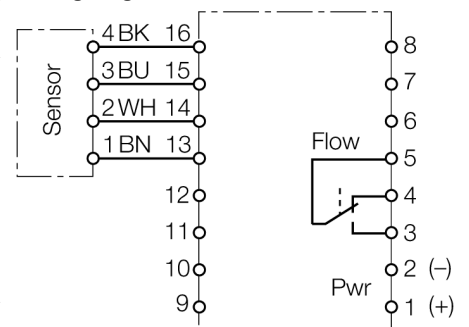

**Functional principle**

Signal processors not only supply insertion and inline sensors with voltage, they also process and display the measured signals. Devices with MK96..., MS96... and MC96... housing styles are available. The individual housing styles are designed for different operating voltages and feature various output and supplementary functions. For intrinsically safe flow sensors it is required to use signal processors with intrinsically safe control circuits of the series MS96...Ex... and MC96...Ex... .

# Signal processor

## MS96 for flow sensors

### MS96-11EX0-R/24VDC

#### Operating manual

##### Intended use

This device fulfils the directive 94/9/EC and is suited for use in explosion hazardous areas according to EN50014 and EN50020. In order to ensure correct operation to the intended purpose it is required to observe the national regulations and directives.

##### For use in explosion hazardous areas conform to classification

II 1 G and II 1 D (Group II, Category 1 G, electrical equipment for gaseous atmospheres and category 1 D, electrical equipment for dust atmospheres).

##### Marking (see device or technical data sheet)

Ex II 1 G and Ex ia IIC T6 acc. to EN60079-11 and -26 and Ex II 1 D Ex iaD 20 T95°C acc. to EN60079-11 and EN61241-0 and -11

##### Local admissible ambient temperature

-20...+60 °C

##### Installation / Commissioning

These devices may only be installed, connected and operated by trained and qualified staff. Qualified staff must have knowledge of protection classes, directives and regulations concerning electrical equipment designed for use in explosion hazardous areas. Please verify that the classification and the marking on the device comply with the actual application conditions.

This device is accessory equipment which features intrinsically safe circuits as well as non-intrinsically safe circuits. It may only be installed outside the explosion hazardous area in dry, clean and well monitored areas. If a declaration of conformity or declaration of the manufacturer as a category 3 device exists, the device may be installed in zone 2. Special conditions for safe operation must be observed. Intrinsically-safe electrical equipment can be connected to the intrinsically-safe connections. All equipment must comply with the demands for operation in the existing zone of the explosion hazardous area. If the intrinsically safe circuits lead to the dust explosion hazardous zones 20 or 21, it is important to ensure that the devices connected to this circuit fulfil the demands for category 1D or 2D and are certified accordingly. If the equipment is interconnected, it is necessary to perform the "Proof of intrinsic safety" (EN 60079-14). Equipment which has been used once to connect intrinsically safe circuits to non-intrinsically safe circuits is no longer suitable for subsequent use with intrinsically safe circuits. Relevant regulations exist for the establishment of intrinsically-safe circuits, mounting of external connection parts as well as the characteristics and laying of cables. Cables and terminals with intrinsically-safe circuits must be marked. They should be separated from non-intrinsically safe circuits or must feature appropriate insulation (EN 60079-14). Observe the prescribed clearances to earthed components and connections of other devices to the intrinsically-safe connections of this device. Unless expressed specifically in the device-specific operating instructions, the approval becomes void if the device is opened, repaired or actions are performed on the device by someone other than approved experts or the manufacturer. Visible changes to the device housing, such as brown-black discolourations caused by heat, as well as holes or bulges also indicate a serious danger. Switch off the device immediately. With the associated electrical equipment the interconnected intrinsically-safe equipment must also be checked. Inspection of a device with regard to the explosion protection can only be performed by an expert or the manufacturer. The operation of the devices is only permitted in conjunction with the permitted data printed on the side of the housing. Before any commissioning or modification of the device interconnections, ensure that the respective regulations, directives and conditions have been complied with and also ensure that use is only for the intended purpose and the safety requirements have been fulfilled.

##### Installation and mounting instructions

Avoid static charging of cables and plastic devices. Please only clean the device with a damp cloth. Do not install the device in a dust flow and avoid build-up of dust deposits on the device.

If the devices and the cable could be subject to mechanical damage, they must be protected accordingly. They must also be shielded against strong electro-magnetic fields.

The pin configuration and the electrical specifications can be taken from the device marking or the technical data sheet.

In order to avoid contamination of the device, please remove possible blanking plugs of the cable glands or connectors only shortly before inserting the cable or opening the cable socket.

##### Special conditions for safe operation

The device must be protected against any kind of mechanical damage.

##### service / maintenance

Repairs are not possible. The approval expires if the device is repaired or modified by a person other than the manufacturer. The most important data from the approval are listed.