

# Accessories

## Programming Board

### For combination with

Speed Controller:  
 SC 1801, SC 2402, SC 2804, SC 5004, SC 5008  
 Brushless DC-Micromotors  
 1525...BRC, 3153...BRC,  
 2232...BX4 SC, 2232...BX4S SC, 2250...BX4 SC,  
 2250...BX4S SC, 3242...BX4 SC, 3268...BX4 SC

### Part No.: 6501.00088

		6501.00088	
Power supply for electronics	U <sub>elo</sub>	3,5 ... 30	V
Power supply for motor	U <sub>mot</sub>	0 ... 30	V
Current consumption of electronics	I <sub>el</sub>	0,1	A
Temperature range: – Operating temperature		0 ... + 65	°C
Dimensions and weight: – Dimensions (L x B x H)		80 x 65 x 31	mm
– Weight		45	g

### General information

#### Description of connectors / controls:

- X1** Terminals for power supplies  
 Pin 1: GND Ground connection of power supply/supplies  
 Pin 2: U<sub>elo</sub> Power supply for electronics  
 Pin 3: U<sub>mot</sub> Power supply for motor winding
- X2, X3, X6, X10** Terminals for motor / motor controller  
 Pin 1: U<sub>P</sub> Power supply for motor electronics  
 Pin 2: U<sub>mot</sub> Power supply for motor winding  
 Pin 3: GND Power supply negative pole  
 Pin 4: U<sub>nsoll</sub> Output for nominal speed setting 0...10V  
 Pin 5: DIR Output for direction of rotation setting  
 Pin 6: FG Input for speed signal from motor controller
- X5** RS232 connector, may optionally be used instead of X9 in PROG mode for programming
- X9** USB connector, may optionally be used instead of X5 in PROG mode for programming
- JP1** Jumper can be removed and connected to an amperemeter for motor current measurement at U<sub>mot</sub>.
- JP3** Jumper to separate power supply for electronics and motor  
 1-2: U<sub>P</sub> = U<sub>mot</sub> » Joint power supply to electronics and motor winding via terminal U<sub>mot</sub>  
 2-3: U<sub>P</sub> = U<sub>elo</sub> » Power supply to electronics via separate terminal U<sub>elo</sub> (separate power supply for electronics and motor winding). Power supply for adapter board also via the terminal selected for U<sub>P</sub>
- JP9** Connector for external signal for U<sub>nsoll</sub>, e.g. PWM signal for speed setting. Note: JP10 must then be removed.

- JP10** Jumper for selection of the source for U<sub>nsoll</sub>. Closed: U<sub>nsoll</sub> adjustable with P1.
- S1** Switch for setting the operating mode  
 PROG mode = software update  
 MOT mode = motor operation
- S2** Switch for setting the direction of rotation of the motor
- S3** Switch for switching the power supply U<sub>P</sub> for the electronics on/off
- P1** P1 is used to set U<sub>nsoll</sub> from 0...10V. JP10 must be closed. The power supply U<sub>P</sub> must be at least 10,5V.
- LED 1** Indicates the adapter board is ready for operation
- LED 2** Indicates the external controller status.  
 ON = ready for operation, OFF = error

#### Start-up

- Connect operating voltage to X1. Use alternatively joint or separate operating voltage for electronics and motor.  
 Note: Pay attention to correct setting of JP3.
- Pay attention to minimum/maximum values for U<sub>mot</sub> and U<sub>elo</sub>.
- S3 in position OFF; JP1 and JP10 closed.
- Connect motor/motor controller to X2, X3, X6 or X10.
- For PROG mode, connect to a Windows PC at X5 (null modem cable) or X9 (USB connection cable type B).
- LED 1 and LED 2 lights up after power-on for U<sub>mot</sub> or U<sub>mot</sub> and U<sub>elo</sub>.

#### Driver installation:

If the adapter board is to be operated via the USB connector X9, a special USB driver must be installed if using Windows XP (further details on request).

### Dimensional drawing and connection information

scale reduced

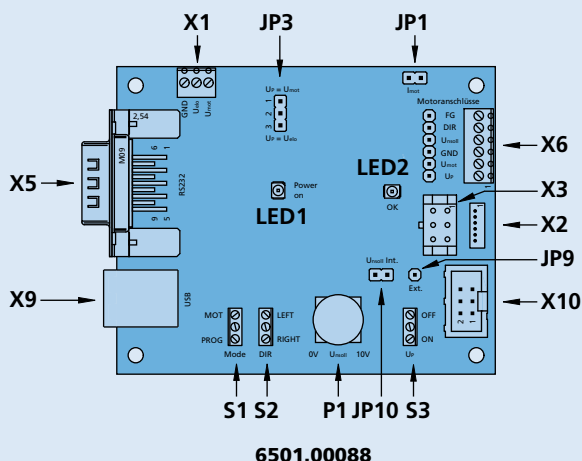

#### Connection

No.	Function
LED 1	Ready for operation
LED 2	Status external controller
<b>Terminals</b>	
X1	Power supply
X2, X3, X6, X10	Connector for motor or SC controller
X5	RS232 connector
X9	USB connector, type B
<b>Jumpers</b>	
JP1	Motor current measurement
JP3	Separation of U <sub>P</sub> from U <sub>mot</sub>
JP9	U <sub>nsoll</sub> external input signal
JP10	U <sub>nsoll</sub> int. setting with P1
<b>Switches</b>	
S1	Operating mode
S2	Direction of motor rotation
S3	Power switch on/off
<b>Potentiometer</b>	
P1	U <sub>nsoll</sub> setting

#### PROG mode

Settings	
S1 PROG	
S2 RIGHT	
S3 OFF	
<b>Terminals</b>	
P1 0V	
JP1 Closed	
JP10 Closed	

#### MOT mode

Settings
S1 MOT
S2 RIGHT or LEFT
S3 OFF - ON
P1 0V ... 10V
JP1 Opt. current measurement
JP10 Select source for U <sub>nsoll</sub>