

INVERSEURS DE SENS DE ROTATION

MOTOR REVERSER (Ready to use)

SW961230

3x400VAC 4KW

Boitier IP20 IP20 housing

Le relais SW961230 est étudié pour démarrer et inverser le sens de rotation de moteurs triphasés asynchrones, avec la commutation de 2 phases uniquement (4 commutateurs : 2 legs). Le produit avec dissipateur intégré, directement montable sur rail DIN avec un calibre des thyristors de 50ARMS, permet de contrôler un moteur avec un courant nominal de 8,5 à 10ARMS soit 4kWatts sous 400VAC, en tenant compte des courants de démarrage et d'inversion. Ces produits sont réalisés avec des composants haute immunité, sans relais REED (tout électronique), avec toutes les protections : RC, VDR,... mais aussi intervrouillage, temporisation entre chaque inversion,... Ces relais sont équipés de thyristors 1600V.

The relay SW961230 is designed for controlling and inverting the direction of a three-phase motors without direct third leg (two legs). With integrated heatsink and directly mounting on a DIN rail, this product with maximum current of semiconductors of 50 Amps. rms, can drive a motor with a current rating of 8,5 up to 10 Amps.rms (or approximately 4kW under 400 V), taking the starting and reversing current into account. These products are designed with very high immunity components, without REED switches (only composed of solid state components), with all protections : RC, VDR,..... temporisation,....., and 1600Volt peak voltage components.

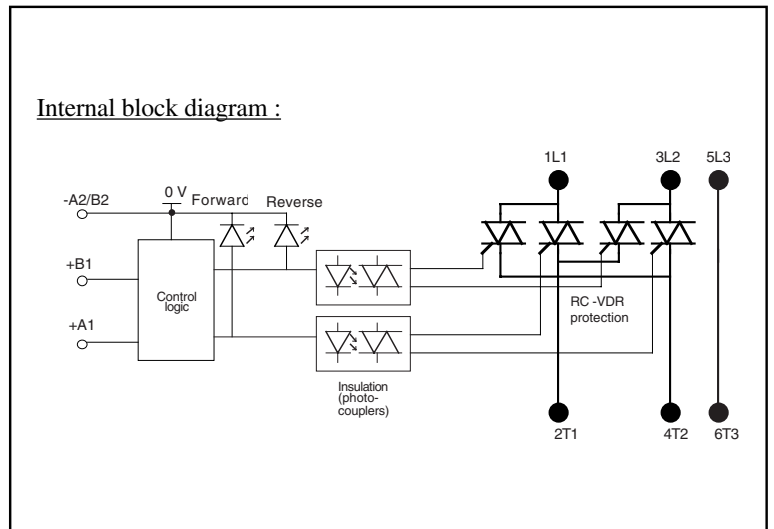
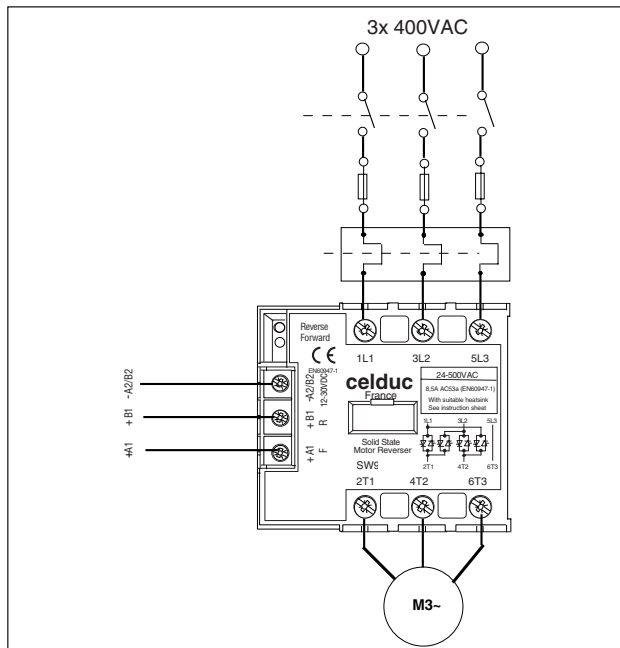
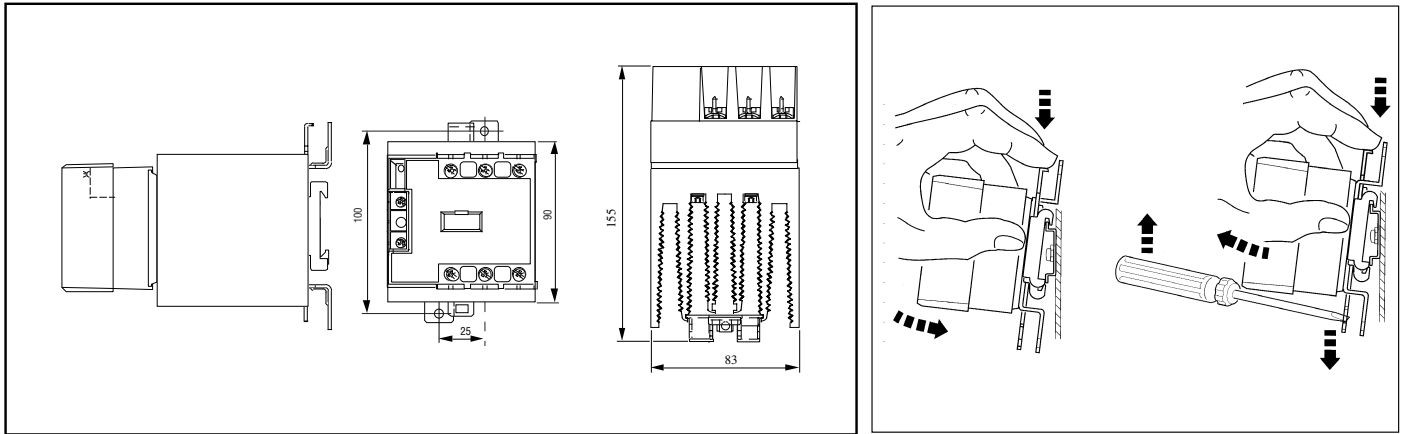
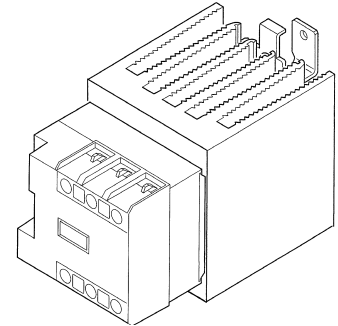

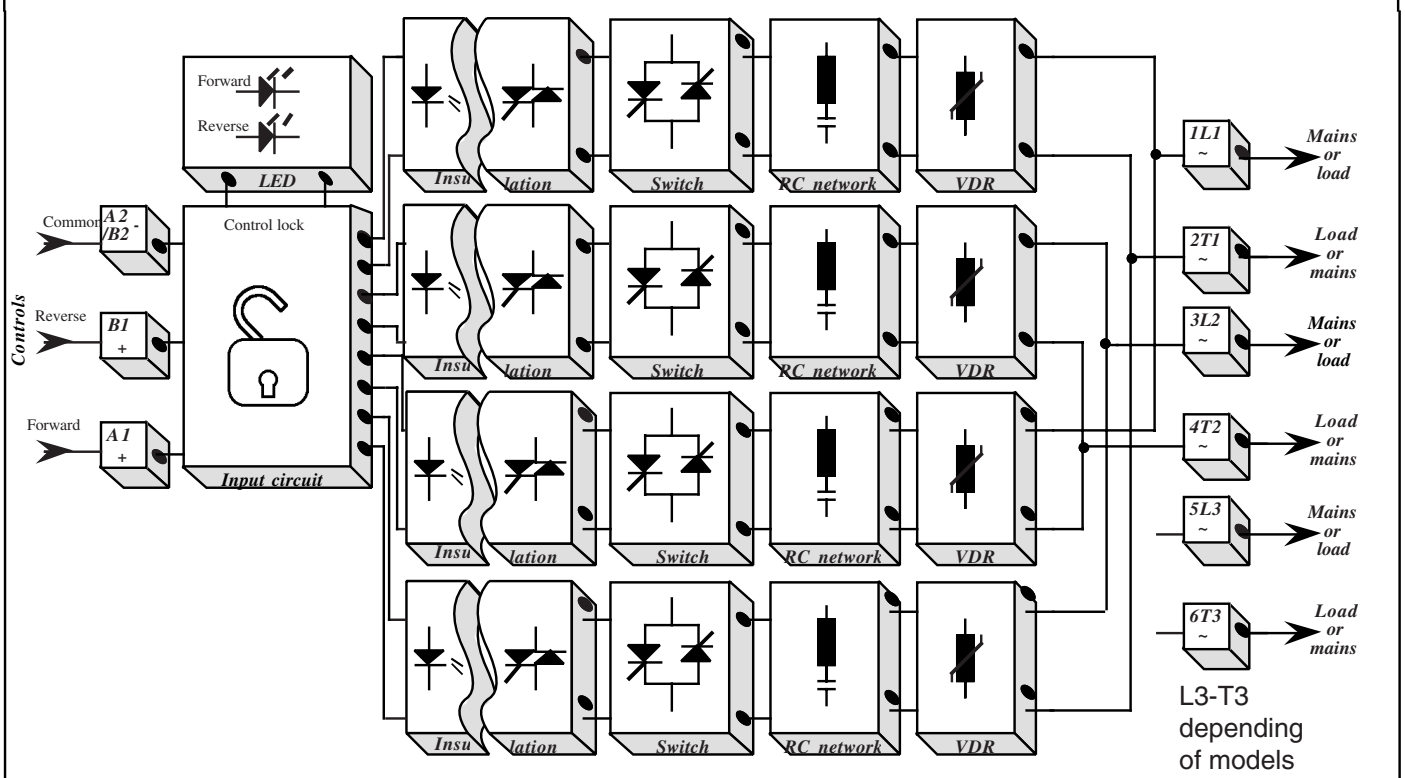
Synoptique interne / Internal diagram for two leg models :

Développé conformément aux normes / Designed in compliance with standards:

- >EN60947-4-2 (V.D.E. 0660 part 109, I.E.C. 158-2) ->EN60947-1 & A11
- >EN60950 (V.D.E. 0805-> office equipment) (Pending approval)
- >U.L. 508 (Pending approval) ->c.U.L (Pending approval)

Control	Plage de tension de commande / Control voltage range	Uc	12-30VDC
	Plage de courant de commande / Control current range	Ic	15-25mADC
	Tension de non fonctionnement/ Release voltage	Ur	6VDC
	LED de visualisation / Display LED		Yes
	protection en cas de cdes simultanées / protection against simultaneous controls		Yes
	tension inverse maxi / Maximum reverse voltage	Urv	30V
	Signal de sortie / Output signal		no output
	temporisation inversion / Reversing time		fixed 70ms

Caractéristiques d'entrée-sortie (à 20°C) / Input-output characteristics (at 20°C)				Unit
Isolement entrée-sortie/ Input-output isolation @500m	Ui	3300		VRMS
Isolement sortie-semelle/ Output-case isolation @500m	Ui	3300		VRMS
Tension assignée isolement/rated impulse voltage	Uimp	4000		V

Caractéristiques générales / General characteristics				Unit
Poids/Weight			à vérifier	g
Plage de température de stockage / Storage temperature range			-40 / +100	°C
Plage de température de fonctionnement/ Operating temperature range			-40 / +100	°C



Output	Tension nominale/ <i>Standard mains voltage</i>	Ue	400 VAC
	Plage de tension de fonctionnement / <i>Mains voltage range</i>	Un	24-520VAC
	tension crête non répétitive/ <i>Non-repetitive maximum peak voltage</i>	Up	1600V
	Courant AC-53 maxi/ <i>Max. nom. current (AC53a=AC3) @40°C</i>	Ie	8,5ARMS
	Puissance moteur/ <i>3 pole power motor (3x400VAC)</i>	Pn	4KW
	Chute directe / <i>Max Direct voltage drop (@Ie)</i>	Ud	1,4VRMS
	Courant crête non répétitif/ <i>Non repetitive overload current (@ 1 cycle of 10ms)</i>	ITSM	550A
	I2t value/ <i>Melting limit (choice of fuse) @10ms</i>	I ² t	1500 A ² s
	Courant minimal de charge / <i>Minimum load current</i>	Imin	100 mA
	facteur de puissance/ <i>Power factor (@ Ith)</i>	Pf	0 up to 1
	Temps d'ouverture et de temporisation/ <i>Turn on time-reversing time(@50Hz)</i>	ton/trv	20ms / 100ms
	Temps d'ouverture/ <i>Turn off time (@50Hz)</i>	toff	10ms
	Courant de fuite / <i>Maximum leakage current (@Ue/50Hz)</i>	Ilk	5 mARMS
	dv/dt / <i>Max off state voltage rise</i>	dv/dt	500V/μs
Fréquence de réseau / <i>Operating frequency range</i>	f	25 up to 440Hz	

E.M.C.	Max conducted immunity level Test accord. to I.E.C.1000-4-4 (bursts)		4KV direct at output, 4KV with a clamp at input no turn on or damage
	Max conducted immunity level Test acc. to I.E.C.1000-4-5 (el. shocks)		2KV in common mode, 1KV in differential mode (Input & output) no turn on or damage
	Max radiated immunity level Test accord. to I.E.C.1000-4-3		10V/m no turn on or damage
	Max electrostatic disch. immunity level Test accord. to I.E.C.1000-4-2		8KV in the air / 4KV touching no turn on or damage
	Max conducted emission level (0,8<Pf<1) Test according to EN55011		The conducted noise made by SSR depends on the wiring configuration and the load type. Test methods recommended by European E.M.C. standards giving results far from reality, we have chosen to advise the right filter suited for the customer's use: Refer to EMC chapter
	Max radiated emission level Test accord. to EN55011 @Ie		<30dBμV from 30 up to 230MHz ; <37dBμV from 230 up to 1000MHz
Misc.	Base/junction thermal resistance	Rthjc	0,5K/W (1 leg)
	Ambient/junction thermal resistance (relay mounted vertically)	Rthja	5K/W
	Weight		130g

Characteristics given at 25°C unless otherwise specified

REVERSERS + HEATSINK SELECTION IN COMPLIANCE WITH EN60947-4-2				
SSR SELECTION motors soft-staters for a permanent current		Relays with heatsink	Ferraz fuse type 14x51 size / max. rating	Overload relay type Klückner-Moeller
Motor power	In motor (@ 400V)	two legs ambient =40°C		
0,75 kW	2A	SW960330 (See data-sheet)	am 8A/500V	Z00-2.4
1,1 kW	2,6A	SW960330 (See data-sheet)	am 8A/500V	Z00-6
1,5 kW	3,5A	SW960330 (See data-sheet)	am 12A/500V	Z00-6
2,2 kW	5A	SW961230	am 12A/500V	Z00-6
3 kW	6,6A	SW961230	am 12A/500V	Z00-10
4 kW	8,5A	SW961230	am 12A/500V	Z00-10

For motor > 4kW consult us : we have some solutions



Caractéristiques thermiques / Thermal curves :

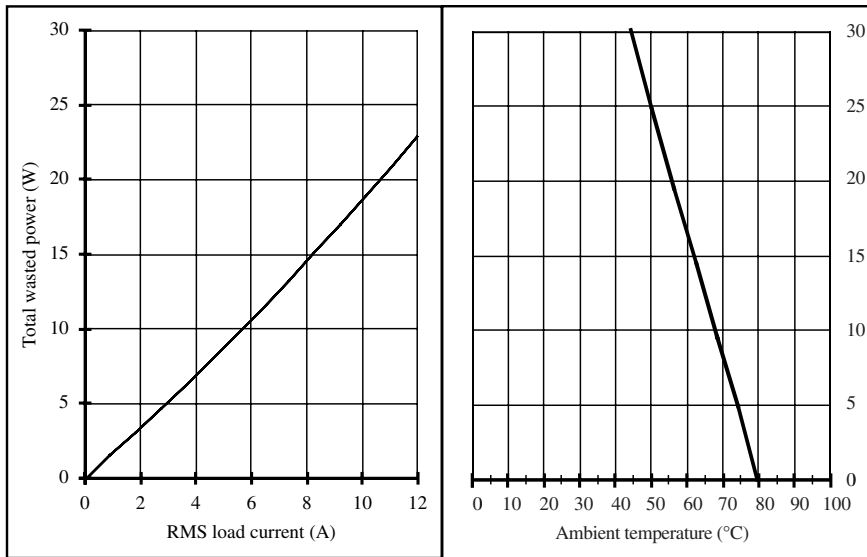

Courant de surcharge non répétitif : ITSM

/ Non repetitive surge peak on-state current : ITSM

1 : No repetitive Itsm (Apeak)=f(t) without voltage reapplied

2 : Repetitive Itsm (Apeak)=f(t) with voltage reapplied for initial Tj =70°C

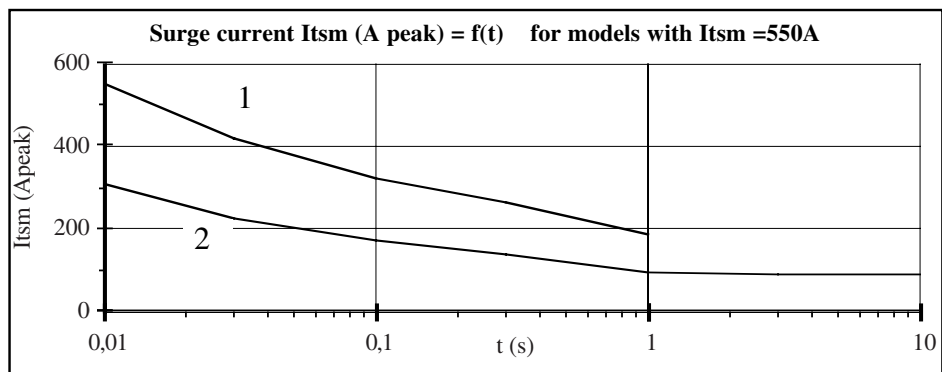

SW9

Wiring of the control circuit:

NUMBER OF WIRES				SCREWDRIVER TYPE		MINIMUM TORQUE
1		2 (DISTRIBUTION)				
SOLID (No ferrule)	FINE STRANDED (With ferrule)	SOLID (No ferrule)	FINE STRANDED (With ferrule)			
						N.m
0,75 ... 2,5 mm ²	0,75 ... 2,5 mm ²	0,75 ... 2,5 mm ²	0,75 ... 2,5 mm ²	0,8 x 5,5 mm	POZIDRIV 2	1,2

SW9

Wiring of the power circuit:

NUMBER OF WIRES				SCREWDRIVER TYPE		MINIMUM TORQUE
1		2 (DISTRIBUTION)				
SOLID (No ferrule)	FINE STRANDED (With ferrule)	SOLID (No ferrule)	FINE STRANDED (With ferrule)			
						N.m
1,5 ... 10 mm ²	1,5 ... 6 mm ²	1,5 ... 10 mm ²	1,5 ... 6 mm ²	0,8 x 5,5 mm	POZIDRIV 2	1,8



ISO 9001
N° 1993/1106a

r e l a i s

NOTE D'APPLICATION : UTILISER UN SW9 POUR L'INVERSION DE SENS
DE ROTATION D'UN MOTEUR ASYNCHRONNE MONOPHASE
A CONDENSATEUR DE DEPHASAGE

APPLICATION NOTE :
**USING A SW9 RELAY FOR REVERSING AN ASYNCHRONOUS SINGLE
PHASE MOTOR WORKING WITH A PHASE SHIFTING CAPACITOR**

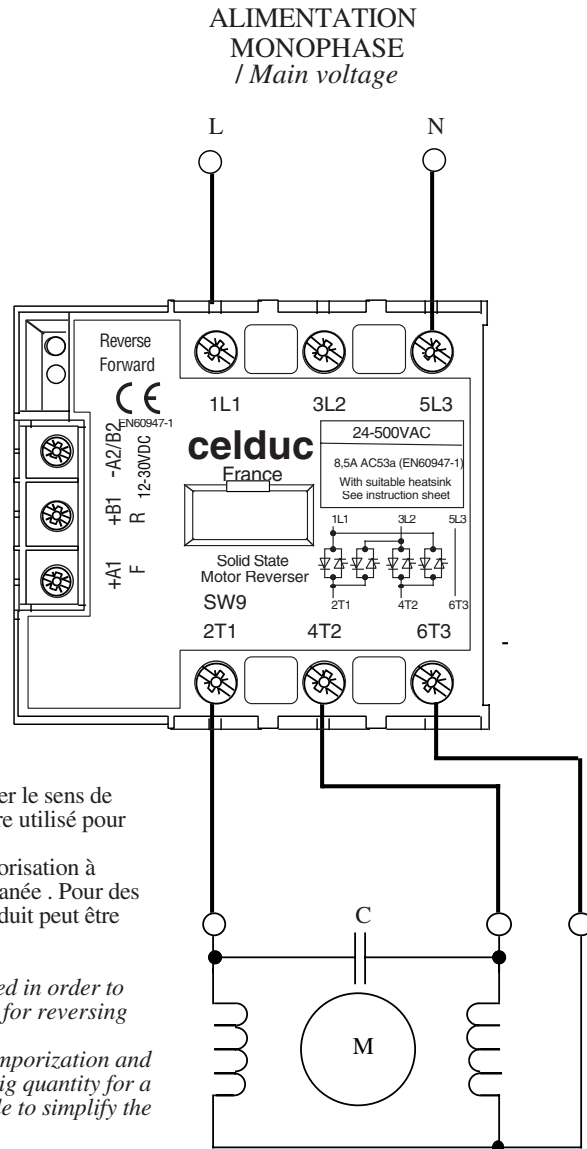

Note : Le relais SW9 développé initialement pour inverser le sens de rotation des moteurs asynchrones triphasés peut aussi être utilisé pour l'inversion de moteurs monophasés .

Ce relais possède 4 voies de puissance , une temporisation à l'inversion et un verrouillage en cas de commande simultanée . Pour des quantités importantes , en utilisation monophasée , le produit peut être simplifié car seulement 2 voies sur 4 sont utilisées .

Note : The SW9 relay which has been initially developed in order to reverse three phase asynchronous motors , can be used for reversing single phase motors .

This relay has 4 power switches , a reversing temporization and a lock in case of simultaneous controls . If you need a big quantity for a single phase use , please contact us , because we are able to simplify the product as only 2 switches among 4 are used .

