



RS stock number : 348-7977

FCTE

Pump Dry Running Sensor



The FCTE is a heat sensor, which is attached to the outlet pipe from a pump. This device works by reacting to the temperature at the outlet of any centrifugal type pump, which will rapidly rise past 45 ° if the inlet water level falls below the centre line of the inlet. The unit will cut off the electrical supply to the pump, so protecting it from damage. Manual resetting of this unit allows the pump to restart.

SPECIFICATION

Set Temperature	45°C 113°F
Switching voltage max.	250Vac
Switching current max. resistive	16A
Pipe diameter range	20-200mm
IP Rating	21



Stock No.	Cynergy3 Part
348-7977	FCTE

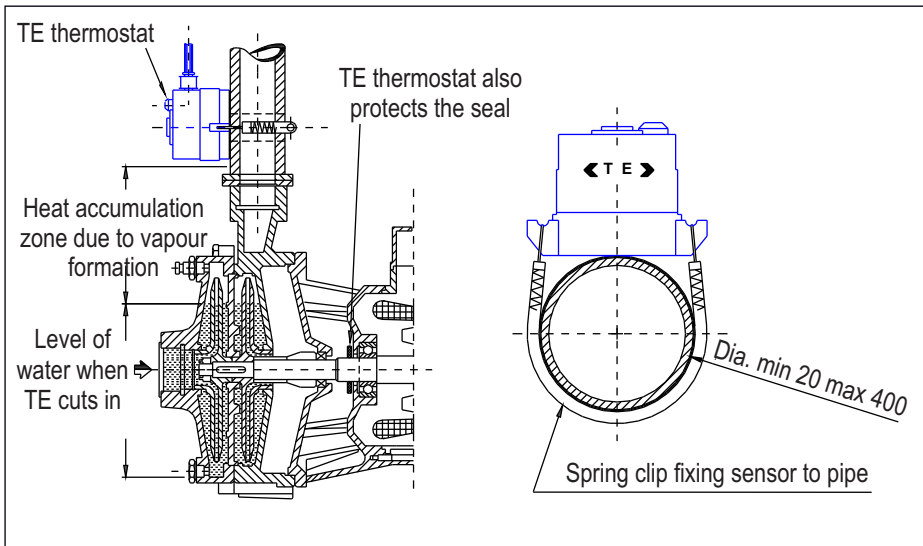

- Prevents dry-running of pump
- Prevents overheating of seals
- High power switching capacity

Cynergy3 Components Ltd
 7 Cobham Road
 Ferndown Industrial Estate
 Wimborne
 Dorset BH21 7PE
 Tel: +44 (0) 1202 897969

sales@cynergy3.com

ISO 9001 CERTIFIED

© 2011 Cynergy3 Components, All Rights Reserved. Specifications are subject to change without prior notice. Cynergy3 Components and the Cynergy3 Components logo are trademarks of Cynergy3 Components Limited.

www.cynergy3.com

FCTE

Pump Dry Running Sensor



INSTALLATION

