

8 7 6 5 4 3 2 1

H

G

F

E

D

C

B

A

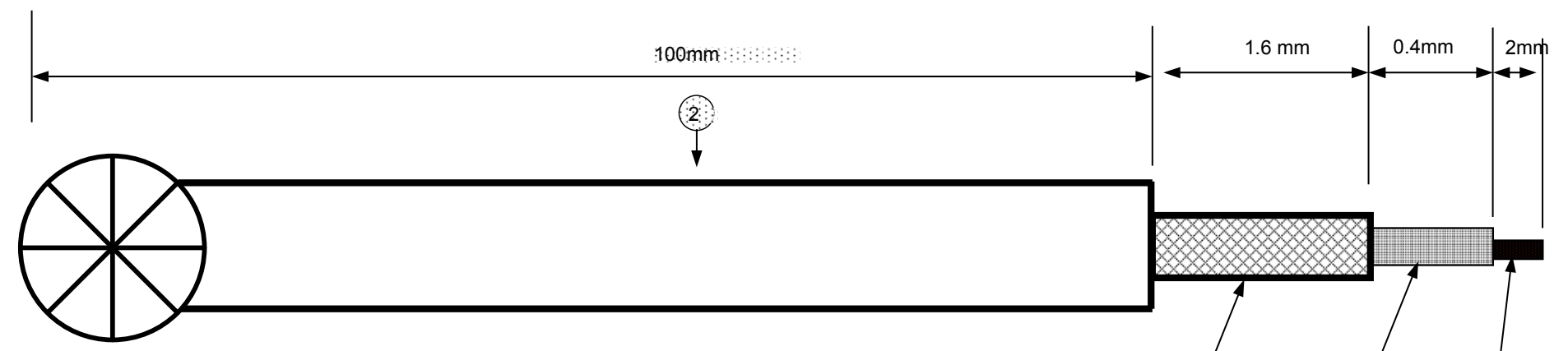

Outer sheath removed to expose the Earth Braid. Earth Braid is solder tinned

Earth Braid removed to expose signal wire Insulation.

Signal wire Insulation removed to expose signal wire. Signal wire solder tinned

Photo of complete CBA

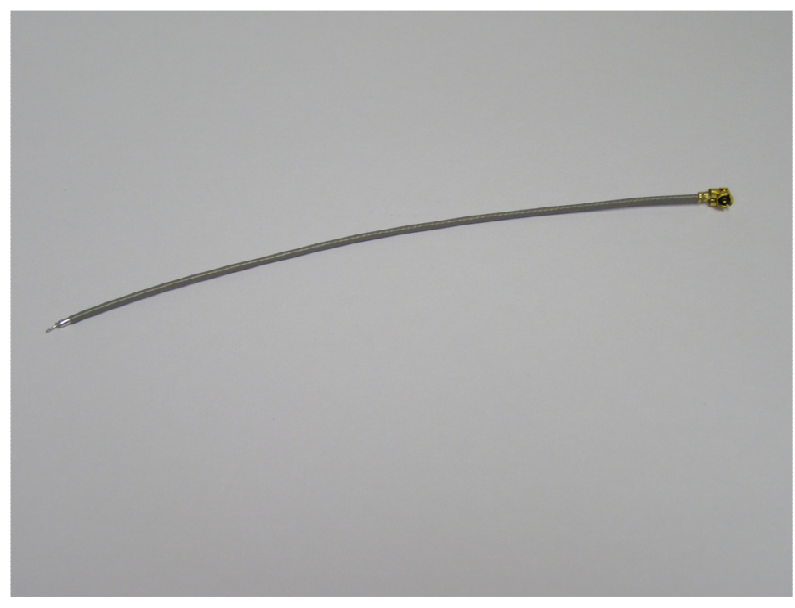

PARTS LIST				
ITEM	QTY	MANUFACTURER	PART NUMBER	DESCRIPTION
1	1			UFL connector designed to mount with a PCB which has
2	2			Coax Cable

DESCRIPTION				
Antenna Cable				
DRAWING NUMBER		DRAWN BY	DATE	REVISED
CBA-ANTGSMPB		JF	7 Oct 09	08/10/2009
REV	REV	INIT	DESCRIPTION	APR
1	1	JF	Initial drg	

8 7 6 5 4 3 2 1