

## Features

## ICE Technology\*

- Tx Temperature Range without Derating
- 120°C Maximum Case Temperature
- -45°C Minimum Operating Temperature
- EN 50155 Compliant
- EN 50121-3-2 Compliant
- CE Marked
- 24, 48 and 110VDC Input Ranges
- Six Sided Shielded Enclosure
- Flat, Ribbed or Baseplate Case Styles
- Efficiency to >89%
- Isolated and Fully Protected Outputs
- Low Quiescent Current

### Description

The RPR30 series DC/DC converters are designed for railway rolling stock applications. Besides covering all the input voltages from 24VDC up to 110VDC, the converters have a very wide operating temperature range of -45°C to +85°C. Although the case size is very compact, the converter contains a built-in Class A EMI filter, so few external components are required. The RPR30 is available in three case styles: a low profile flat top case, a ribbed case with a built-in heatsink and the baseplate case for high vibration or bulkhead-mounting applications. They are EN 50155 and EN 50121-3-2 compliant.

### Selection Guide 24V, 48V and 110V Input Types

Part Number	Nominal Input VDC	Nom. Input Range VDC	Lockout Voltage VDC	Output Voltage VDC	Output Current mA
RPR30-243.3S**	24	12-36V	8.5V	3.3	9100
RPR30-2405S**	24	12-36V	8.5V	5	6000
RPR30-2412S**	24	12-36V	8.5V	12	2500
RPR30-2415S**	24	12-36V	8.5V	15	2000
RPR30-2424S**	24	12-36V	8.5V	24	1250
RPR30-483.3S**	48	25-75	17.5	3.3	9100
RPR30-4805S**	48	25-75	17.5	5	6000
RPR30-4812S**	48	25-75	17.5	12	2500
RPR30-4815S**	48	25-75	17.5	15	2000
RPR30-4824S**	48	25-75	17.5	24	1250
RPR30-1103.3S**	110	40-160	36	3.3	9100
RPR30-11005S**	110	40-160	36	5	6000
RPR30-11012S**	110	40-160	36	12	2500
RPR30-11015S**	110	40-160	36	15	2000
RPR30-11024S**	110	40-160	36	24	1250
RPR30-2412D**	24	12-36V	8.5V	±12	±1250
RPR30-2415D**	24	12-36V	8.5V	±15	±1000
RPR30-2424D**	24	12-36V	8.5V	±24	±620
RPR30-4812D**	48	25-75	17.5	±12	±1250
RPR30-4815D**	48	25-75	17.5	±15	±1000
RPR30-48124D**	48	25-75	17.5	±24	±620
RPR30-11012D**	110	40-160	36	±12	±1250
RPR30-11015D**	110	40-160	36	±15	±1000
RPR30-11024D**	110	40-160	36	±24	±620

\*\* add suffix "-F" for low profile Flat case or "-B" for Baseplate case and no suffix is the Ribbed case.  
add "1" before suffix for neg. CTRL logic e.g. -1, -1B, -1F, etc.

## POWERLINE+

Railway-Converter

with 3 year Warranty

# RECOM

## 30 Watt Single & Dual Output

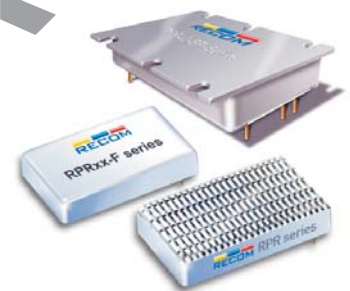

**EN-50155 (Pending)**  
**EN-60950 (Pending)**

# RPR30

### \* ICE Technology

**ICE (Innovation in Converter Excellence) uses state-of-the-art techniques to minimise internal power dissipation and to increase the internal temperature limits to extend the ambient operating temperature range to the maximum.**

Refer to Application Notes

### Railway Input Voltage Requirements

Nominal Input Voltage	EN50155			NF F 01-510			RPR30		
	Input Range	Min. Input (0.1s)	Max Input (1s)	Input Range	Min. Input (0.1s)	Max Input (1s)	Input Range	Min. Input (0.1s)	Max Input (1s)
24V	16.8~30V	14.4V	33.6V	18~34V	12V	40V	12~36V	9V	40V
48V	33.6~60V	28.8V	67.2V				25~75V	18V	80V
72V	50.4~90V	43.2V	100.8V	50~90V	36V	115V	40~160V	36V	176V
96V	67.2~120V	57.6V	134.4V				40~160V	36V	176V
110V	77~137.5V	66V	154V	77~137V	55V	176V	40~160V	36V	176V

### Specifications (typical at nominal input and 25°C unless otherwise noted)

Input Voltage Range (continuous)	complies with EN50155 and NFF 01-510 (Un=24V) complies with EN50155 and NFF 01-510 (Un=48V) complies with EN50155 and NFF 01-510 (Un=72V, 96V & 110V)	12-36VDC 25-75VDC 40-160VDC
Low Transient operating voltage (100ms)	complies with EN50155 and NFF 01-510	Un x 0.5
High Transient operating voltage (1 second)	complies with EN50155 and NFF 01-510	Un x 1.6
Allowed Input Ripple	complies with EN50155	15%
Input Reflected Ripple	nominal Vin and full load	20mA <sub>p-p</sub>
Supply Interruption	complies with EN50155, Class S1	(complies with S2 using circuit below)
Supply Changeover	complies with EN50155, Class C1	(complies with C2 using circuit below)
Start Up Time	nominal Vin and constant resistive load	2ms typ., 5ms max.
Remote ON/OFF <sup>(1)</sup>	Logic High Logic Low	Open or 3.0V < Vr < 5.5V Short or 0V < Vr < 1.2V
Remote OFF input current	Nominal input	2mA typ.
Output Voltage Accuracy	50% Load and nominal Vin	±1.5%
Voltage Adjustability	Single Output only	±10%
Minimum Load		0%
Line Regulation	low line, high line at full load	±0.3%
Load Regulation	10% to 100% full load	±0.5%
Cross Regulation (10% <-> 100% Load)	Dual Outputs only	3% typ. / 5% max.
Ripple and Noise (20MHz bandwidth limited)	(measured with 1µF capacitor across outputs)	1% Vout typ. / 3% max.
Temperature Coefficient		±0.04%/°C max.
Transient Response	25% load step change	800µs
Over Load Protection	% of full load at nominal Vin	120% typ.
Short Circuit Protection		Current limit, automatic recovery
Output Over Voltage Protection	Single Output Dual Output	Converter shutdown if Vout > Vout nominal + 20% Converter shutdown if Vout > Vout nominal + 10%
Isolation Voltage	According to EN50155 12.2.9.2	Tested at 1600VDC/1 minute
Isolation Resistance	According to EN50155 12.2.9.1	10MΩ min.
Isolation Capacitance		1500pF max.
Operating Frequency		260kHz ± 40kHz
Operating Temperature Range (Tx) (Ambient Air, Free Convection)	complies with EN50155: 4.1.2 and EN50125-1 with derating	-45°C to +85°C -45°C to +100°C
Maximum Case Temperature		+120°C
Over Temperature Protection		internal thermistor
Storage Temperature Range		-55°C to +125°C
Relative Humidity		5% to 95% RH

# POWERLINE+

## DC/DC-Converter

# RPR30-S\_D Series

### Specifications (typical at nominal input and 25°C unless otherwise noted)

Case Material <sup>(2)</sup>	Aluminium	
Potting Material	Silicone (UL94-V0)	
Weight	Flat Case	34g
	Ribbed Case	39g
	Baseplate Case	43g
Packing Quantity	Flat, Ribbed Case	5 pcs per Tube
	Baseplate Case	Single packed
Safety Standards	CE Marked	certified to EN-60950-1, 1st Edition
Thermal Performance	Cold	-45°C / 2 Hours
	Dry Heat	+85°C / 6 Hours
	Damp Heat, Cyclic	+25°C/+55°C, 85%RH / 2 x 24 Hours
conforms to EN50155: 12.2.3/4/5		
Vibration (complies with EN61373)	5-150Hz, 10G, All three axes, 15 hours	
Input Filter	Built-in Pi Filter	
Conducted Emissions	EN50121-3-2	Class A
Radiated Emissions	EN50121-3-2	Class A
ESD	EN50121-3-2	Perf. Criteria B
Radiated Immunity	EN50121-3-2	Perf. Criteria A
Fast Transient	EN50121-3-2	Perf. Criteria A
Surge	EN50121-3-2	Perf. Criteria B
Conducted Immunity	EN50121-3-2	Perf. Criteria A
MTBF calculated according to BELLCORE TR-NWT-000332 Case I: 50% Stress, Temperature at 50°C (Ground Benign)		2195 x 10 <sup>3</sup> hours

### Recommended PCB Layout

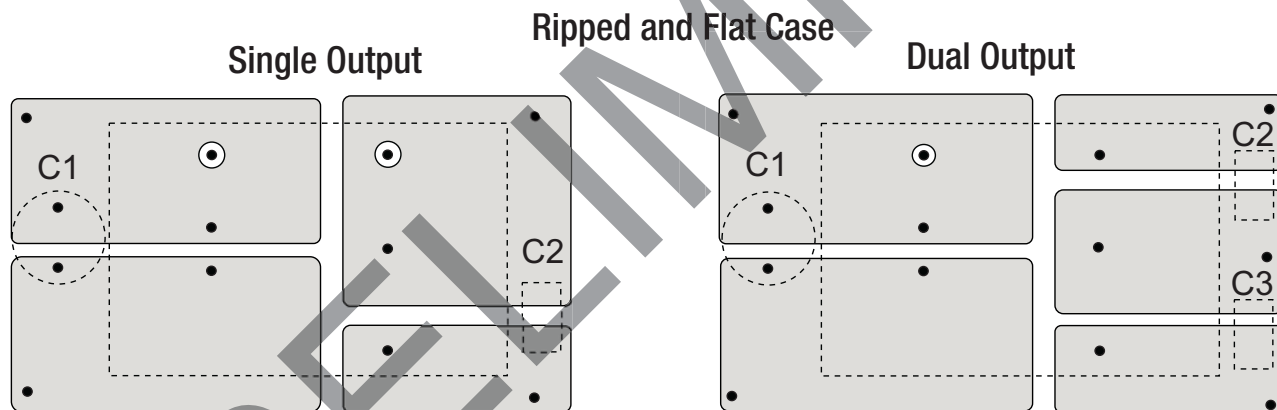

Baseplate Case- suggested PCB layout

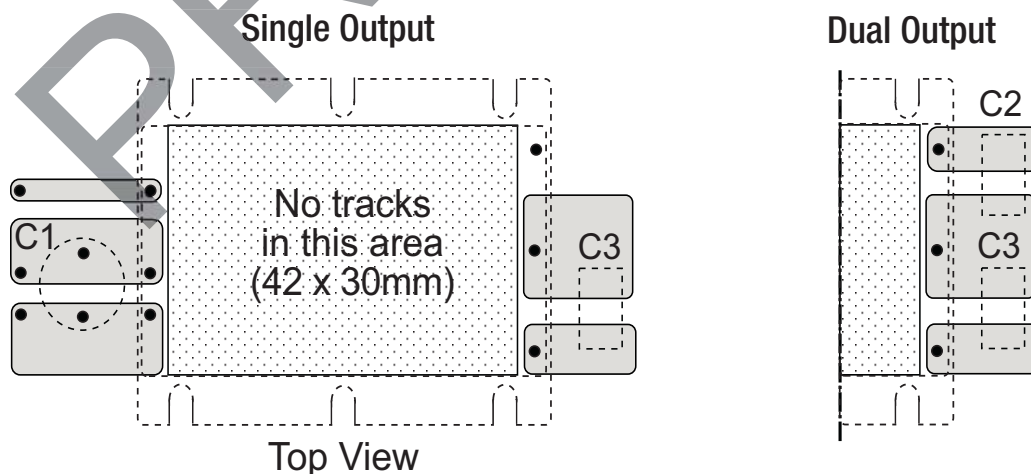

Input Fuse is recommended, but optional. Recommended fuse rating = double maximum input current, time delay type.

Input Capacitor, C1, is required to meet surge specifications. Output Capacitors C2/C3 are recommended, but not required for normal operation. Typical capacitor values are 1µF/100V MLCC

To ensure optimum thermal performance, use large areas of copper on the PCB to assist with heat dissipation and mount the converter vertically.

#### EN50155 / NF F 01-510 Input Filter

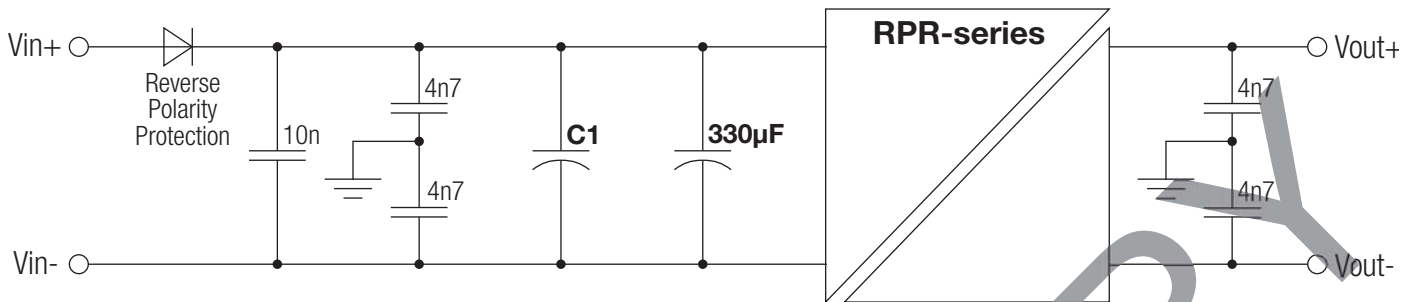

#### EN50155 Class S2 Compliance

To meet the requirements of EN50155 Class S2 (disconnection of supply for 10ms), capacitor C1 may be required. The value of C1 can be calculated from the following formula:

$$C1 + 330\mu\text{F} = (2 \times W \times t) / (\text{Eff.} \times (U_n^2 - U_{\text{min}}^2))$$

where W = output power, t = disconnect time, Eff = Converter efficiency,  $U_n$  = nominal input voltage and  $U_{\text{min}}$  = the UVL voltage of the converter  
e.g., for the RPR30-2405S:  $C1 = (2 \times 30 \times 0.01) / (0.88 \times (24^2 - 8.5^2)) = 1353\mu\text{F} - 330\mu\text{F} = 1003\mu\text{F}$  minimum.

Any overcurrent protective devices fitted must not react faster than 0.01s and be capable of supplying the initial inrush current without tripping.

#### Suggested component values:

Input Voltage ( $U_n$ )	Capacitor C1	Inrush Current (after 10ms)
24V	$C1 = 1353\mu\text{F} - 330\mu\text{F} = 680\mu\text{F}/50\text{V} + 470\mu\text{F}/50\text{V}$	<0.1A
48V	$C1 = 341\mu\text{F} - 330\mu\text{F} = 15\mu\text{F}/100\text{V}$	<0.1A
72V	C1 not required	<0.1A
96V	C1 not required	<0.1A
110V	C1 not required	<0.1A

#### EN50155 Class C2 Compliance

To meet the requirements of EN50155 Class C2 (disconnection of supply for 30ms), capacitor C1 may need to be increased:

#### Suggested component values:

Input Voltage ( $U_n$ )	Capacitor C1	Inrush Current (after 10ms)
24V	$C1 = 4060\mu\text{F} - 330\mu\text{F} = 2200\mu\text{F}/50\text{V} + 2200\mu\text{F}/50\text{V}$	<3A
48V	$C1 = 1023\mu\text{F} - 330\mu\text{F} = 470\mu\text{F}/100\text{V} + 470\mu\text{F}/100\text{V}$	<0.1A
72V	$C1 = 419\mu\text{F} - 330\mu\text{F} = 150\mu\text{F}/200\text{V}$	<0.1A
96V	$C1 = 258\mu\text{F} - 330\mu\text{F} = C1$ not required	<0.1A
110V	$C1 = 189\mu\text{F} - 330\mu\text{F} = C1$ not required	<0.1A

#### Notes :

- The ON/OFF pin voltage is referenced to negative input. The pin is pulled high internally.  
ON/OFF control is standard with positive logic: e.g. RPR30-2405S, RPR30-4805D-B.  
Add "1" before the suffix for negative logic: e.g. RPR30-2405S-1, RPR30-11005D-1B.  
Positive logic: 0 = OFF, 1 = ON. The converter will be ON if the CTRL is left open.  
Negative logic: 1 = OFF, 0 = ON. The converter will be OFF if the CTRL is left open..
- To ensure a good all-round electrical contact, the baseplate is pressed firmly into place within the aluminium housing. The hydraulic press can leave tooling marks and deformations to both the housing and baseplate. The case is anodised aluminium, so there will be natural variations in the case colour and the aluminium is not scratch resistant. Any resultant marks, scratches and colour variations are cosmetic only and do not affect the operation or performance of the converters.
- The converter is supplied with a protective adhesive tape to keep the top surface clean. The tape is heat resistant and the converter can be soldered into place without removing the tape. The tape should be removed just before final installation.

# POWERLINE+

DC/DC-Converter

# RPR30-S\_D Series

Package Style and Pinning (mm)

## Standard Case (No suffix)

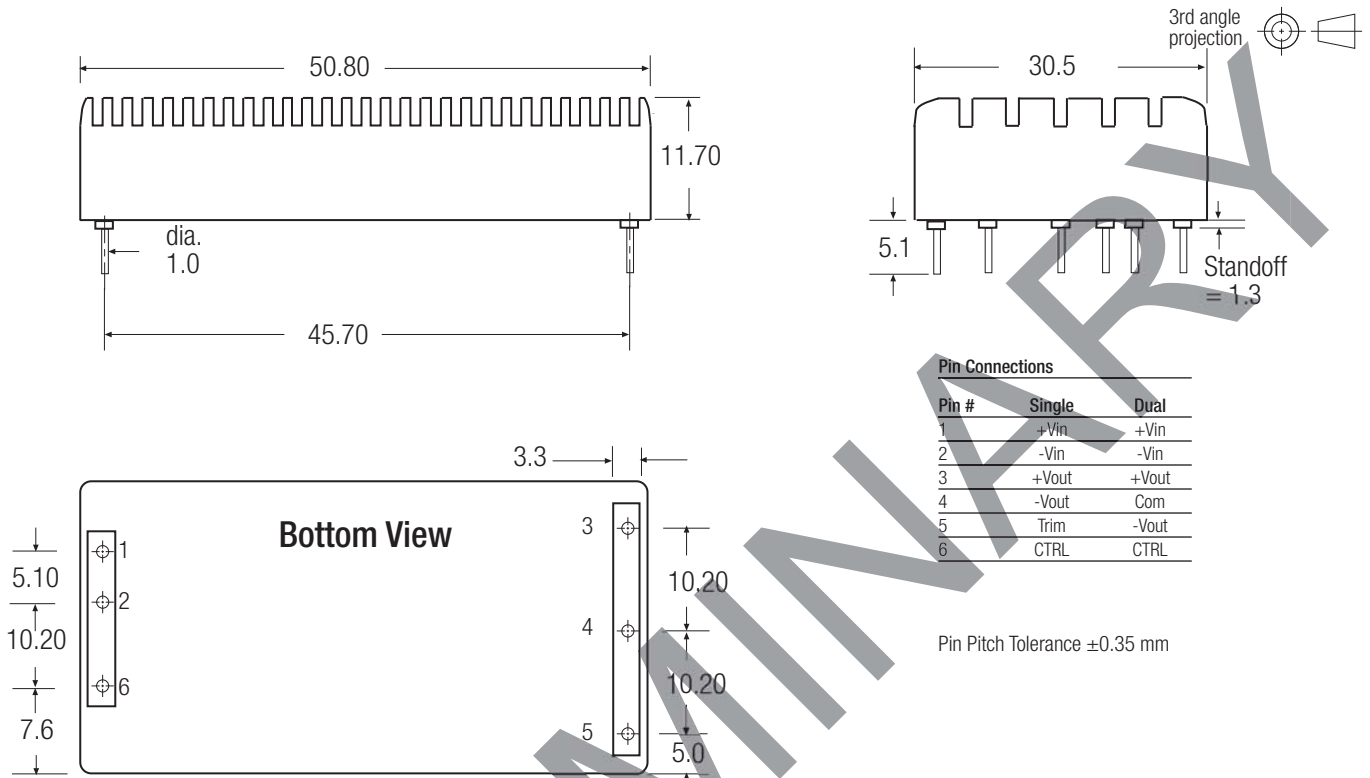

## Flat Case (-F suffix)

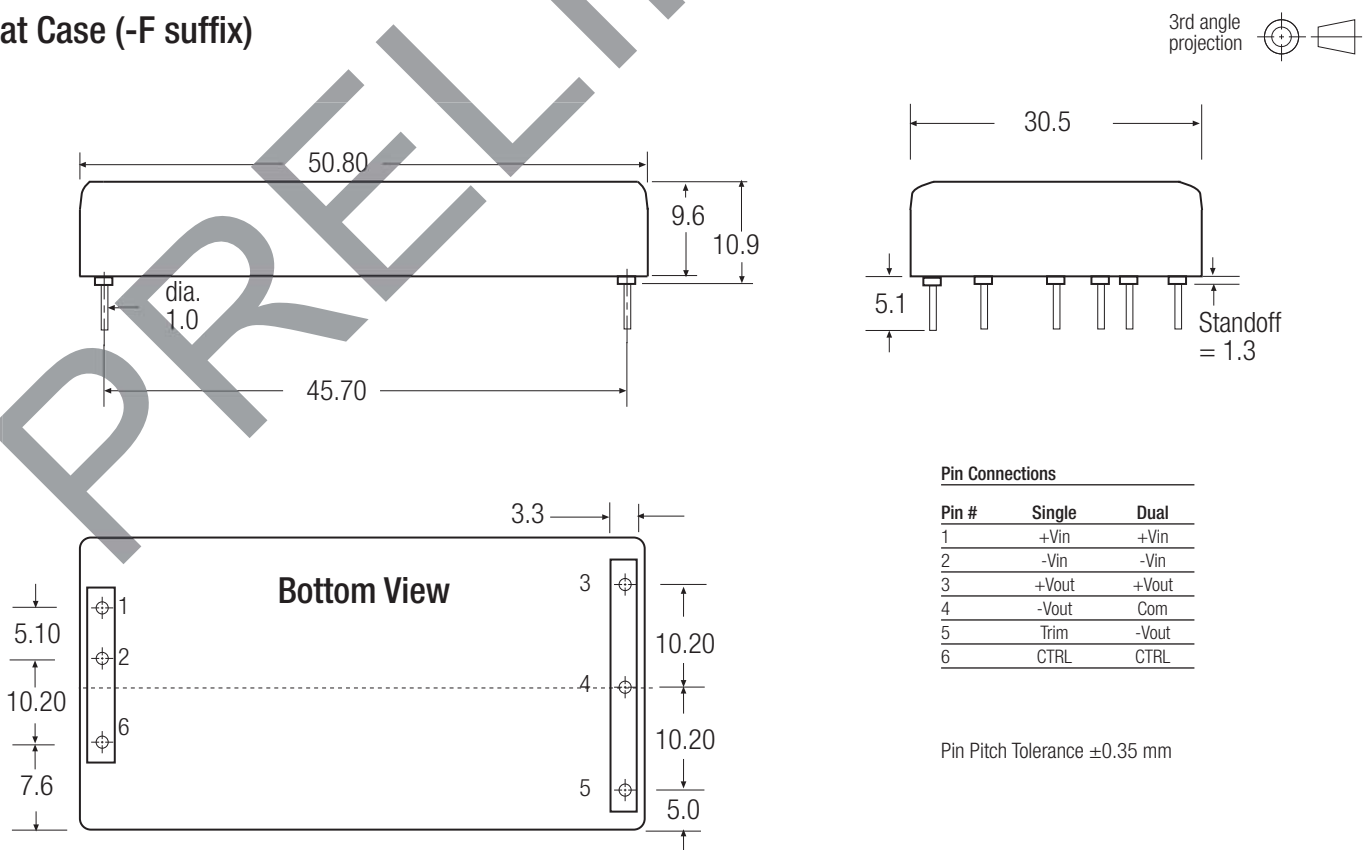

# POWERLINE+

DC/DC-Converter

# RPR30-S\_D Series

Package Style and Pinning (mm)

## Baseplate Case (-B Suffix)

3rd angle projection 

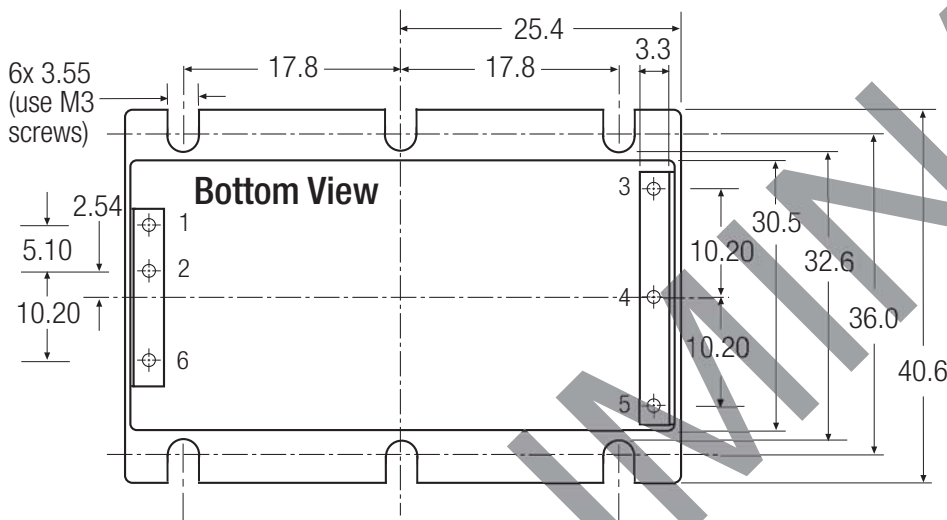
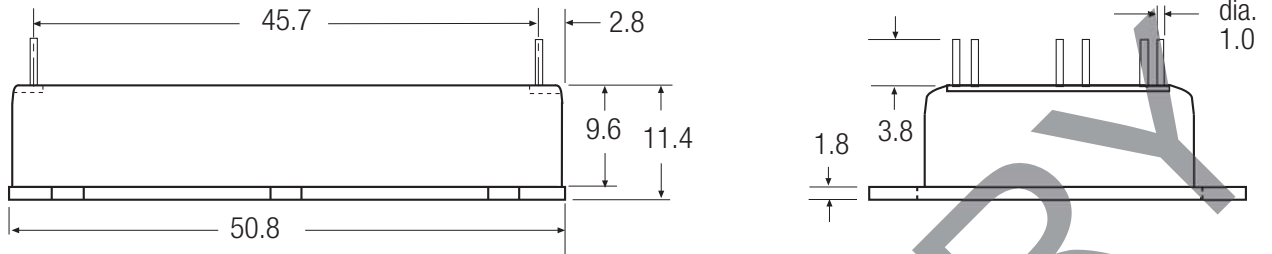

### Pin Connections

Pin #	Single	Dual
1	+Vin	+Vin
2	-Vin	-Vin
3	+Vout	+Vout
4	-Vout	Com
5	Trim	-Vout
6	CTRL	CTRL

Pin Pitch Tolerance  $\pm 0.35$  mm

RPR30

## Baseplate Case Fixing - Mounting onto Heatsink/Bulkhead

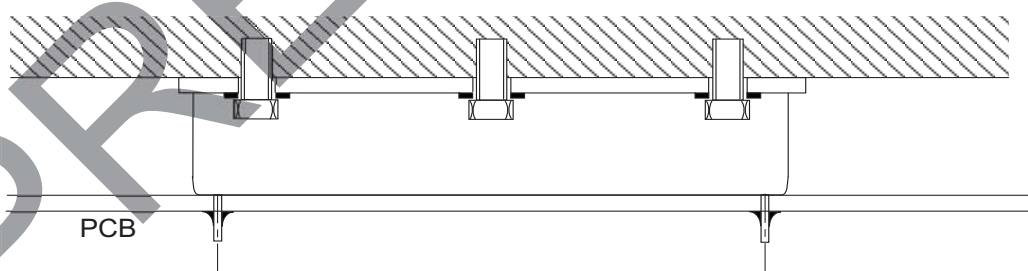

## Baseplate Case Fixing - Anti Vibration Mounting onto PCB

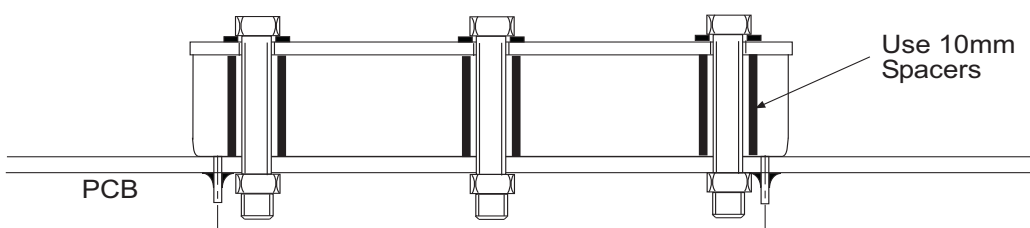

Use 10mm Spacers