

WIRING DIAGRAM

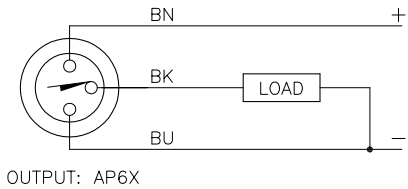

SHORT-CIRCUIT AND OVERLOAD PROTECTED

LOCKNUT LN-SS08

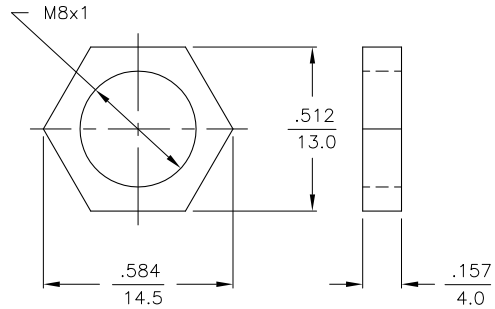

SPECIFICATIONS

| | |
|------------------------------|---|
| RATED OPERATING DISTANCE | 3.0 mm = .118" (NOMINAL) |
| MOUNTING MODE | NON-FLUSH |
| TEMPERATURE DRIFT | ≤ ± 10% |
| HYSTERESIS | 3-15% |
| MIN. REPEAT ACCURACY | ≤ 2% |
| OPERATING TEMPERATURE | -25°C to +70°C (-13°F to +158°F) |
| RATED OPERATIONAL VOLTAGE | 10-30 VDC |
| RIPPLE | ≤ 10% |
| DC RATED OPERATIONAL CURRENT | ≤ 150 mA |
| NO-LOAD CURRENT | ≤ 15 mA |
| RESIDUAL CURRENT | ≤ 0.1 mA |
| RATED INSULATION VOLTAGE | ≤ 0.5 kV |
| SHORT-CIRCUIT PROTECTED | YES |
| MAX VOLTAGE DROP | ≤ 1.8 V |
| WIRE BREAKAGE PROTECTION | INCORPORATED |
| REVERSE POLARITY PROTECTION | INCORPORATED |
| OUTPUT FUNCTION | 3-WIRE, NORMALLY OPEN, PNP |
| MAX. SWITCHING FREQUENCY | ≤ 3.0 kHz |
| HOUSING MATERIAL | METAL, A4 1.4404 (AISI 316L) |
| ACTIVE FACE MATERIAL | PLASTIC, PA12-GF20 |
| CONNECTION | M8x1 |
| SHOCK RESISTANCE | 30 g, 11 ms |
| VIBRATION RESISTANCE | 55 Hz, 1 mm AMPLITUDE (IN ALL 3 PLANES) |
| DEGREE OF PROTECTION | IP67 |
| SWITCHING STATUS INDICATION | LED: YELLOW |

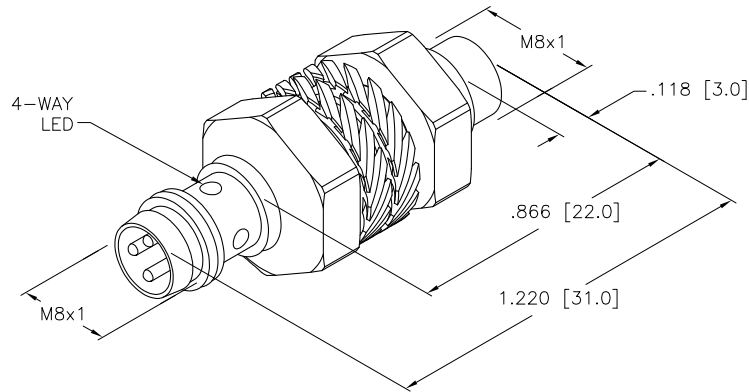

SOURCE DRAWING - FOR REFERENCE ONLY

| | | | | | | | |
|--------------------------------|-------------|---|----------|---|--------------|--|--------------|
| RELATED DOCUMENTS | | 3RD ANGLE PROJECTION | | THIS DRAWING IS PROPERTY OF TURCK INC. USE OF THIS DOCUMENT WITHOUT WRITTEN PERMISSION IS PROHIBITED. | | TURCK INC High Technology Sensors and Automation Controls 3000 CAMPUS DRIVE MINNEAPOLIS, MN 55441 1-800-544-7769 (763) 553-7300 (763) 553-0708 fax turck.com | |
| 1. 2. 3. 4. | | | | DRFT IK | DATE 2/18/97 | DESCRIPTION NI 3-EG08K-AP6X-V1131 | |
| MATERIAL SEE SPECIFICATIONS | | ALL DIMENSIONS DISPLAYED ON THIS DRAWING ARE FOR REFERENCE ONLY | | DSGN - | SCALE NTS | IDENTIFICATION NO. S4669650 | |
| FINISH | | CONTACT TURCK FOR MORE INFORMATION | | UNIT OF MEASUREMENT INCH [MILLIMETER] | | REV A | |
| A DRAWING RELEASE | | RDS | 11/05/02 | 5504 | | DO NOT SCALE THIS DRAWING | |
| REV | DESCRIPTION | BY | DATE | ECO NO. | | FILE: S4669650 | SHEET 1 OF 1 |

| | | | | |
|-----|-----------------|-----|----------|---------|
| A | DRAWING RELEASE | RDS | 11/05/02 | 5504 |
| REV | DESCRIPTION | BY | DATE | ECO NO. |