

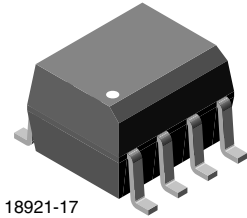

# High Speed Optocoupler, 10 MBd, SOIC-8 Package

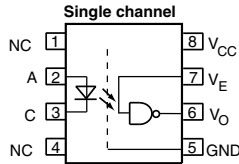

18921-17



VO0600T, VO0601T, VO0611T

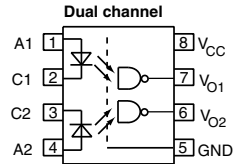

VO0630T, VO0631T, VO0661T

18921-26



## FEATURES

- Choice of CMR performance of 15 kV/μs, 5 kV/μs, and 100 V/μs
- High speed: 10 MBd typical
- + 5 V CMOS compatibility
- Pure tin leads
- Guaranteed AC and DC performance over temperature: - 40 °C to + 100 °C temp. range
- Meets IEC 60068-2-42 (SO<sub>2</sub>) and IEC 60068-2-43 (H<sub>2</sub>S) requirements
- Low input current capability: 5 mA
- Material categorization: For definitions of compliance please see [www.vishay.com/doc?99912](http://www.vishay.com/doc?99912)



RoHS COMPLIANT

## APPLICATIONS

- Microprocessor system M interface
- PLC, ATE input/output isolation
- Computer peripheral interface: SPI
- Digital fieldbus isolation: CC-Link, DeviceNet, profibus, SDS
- High speed A/D and D/A conversion
- AC plasma display panel level shifting
- Multiplexed data transmission
- Digital control power supply
- Ground loop elimination

## DESCRIPTION

The VO06xxT family are single and dual channel 10 MBd optocoupler utilizing a high efficient input LED coupled with an integrated optical photodiode IC detector. The detector has an open drain NMOS-transistor output, providing less leakage compared to an open collector Schottky clamped transistor output. For the single channel type, an enable function on pin 7 allows the detector to be strobed. The internal shield provides a guaranteed common mode transient immunity of 5 kV/μs for the VO0601T and VO0631T and 15 kV/μs for the VO0611T and VO0661T. The use of a 0.1 μF bypass capacitor connected between pin 5 and 8 is recommended.

## AGENCY APPROVALS

- UL1577, file no. E52744
- cUL-file no. E52744, equivalent to CSA bulletin 5A
- DIN EN 60747-5-5 (VDE 0884), available with option 1

## ORDERING INFORMATION

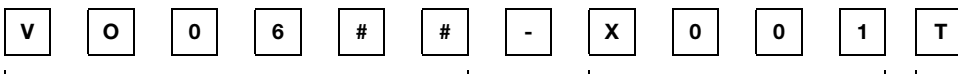

PART NUMBER

PACKAGE OPTION

TAPE AND REEL

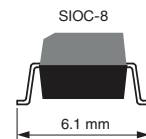

AGENCY CERTIFIED/PACKAGE	CHANNELS 1			CHANNELS 2		
	CMR (kV/μs)			CMR (kV/μs)		
<b>UL, cUL</b>	<b>0.1</b>	<b>5</b>	<b>15</b>	<b>0.1</b>	<b>5</b>	<b>15</b>
SOIC-8	VO0600T	VO0601T	VO0611T	VO0630T	VO0631T	VO0661T
<b>UL, cUL, VDE</b>	<b>0.1</b>	<b>5</b>	<b>15</b>	<b>0.1</b>	<b>5</b>	<b>15</b>
SOIC-8	-	VO0601-X001T	-	-	VO0631-X001T	-

**TRUTH TABLE** (positive logic)

LED	ENABLE <sup>(1)</sup>	OUTPUT
On	H	L
Off	H	H
On	L	H
Off	L	H
On	NC	L
Off	NC	H

**Note**

<sup>(1)</sup> Only applicable for single channel devices

**ABSOLUTE MAXIMUM RATINGS** ( $T_{amb} = 25\text{ }^{\circ}\text{C}$ , unless otherwise specified)

PARAMETER	TEST CONDITION	SYMBOL	VALUE	UNIT
<b>INPUT</b>				
Average forward current (single channel)		$I_F$	20	mA
Average forward current (dual channel)		$I_F$	15	mA
Reverse input voltage		$V_R$	5	V
Enable input voltage (single channel)		$V_E$	$V_{CC} + 0.5\text{ V}$	V
Enable input current (single channel)		$I_E$	5	mA
Surge current	$t = 100\text{ }\mu\text{s}$	$I_{FSM}$	200	mA
Output power dissipation (single channel)		$P_{diss}$	35	mW
Output power dissipation (per channel for dual channel)		$P_{diss}$	25	mW
<b>OUTPUT</b>				
Supply voltage	1 min maximum	$V_{CC}$	7	V
Output current		$I_O$	50	mA
Output voltage		$V_O$	7	V
Output power dissipation (single channel)		$P_{diss}$	85	mW
Output power dissipation (per channel for dual channel)		$P_{diss}$	60	mW
<b>COUPLER</b>				
Isolation test voltage	$t = 1\text{ s}$	$V_{ISO}$	4000	$V_{RMS}$
Storage temperature		$T_{stg}$	- 55 to + 150	$^{\circ}\text{C}$
Operating temperature		$T_{amb}$	- 40 to + 100	$^{\circ}\text{C}$
Lead solder temperature	for 10 s		260	$^{\circ}\text{C}$
Solder reflow temperature <sup>(1)</sup>	for 1 min		260	$^{\circ}\text{C}$

**Notes**

- Stresses in excess of the absolute maximum ratings can cause permanent damage to the device. Functional operation of the device is not implied at these or any other conditions in excess of those given in the operational sections of this document. Exposure to absolute maximum ratings for extended periods of the time can adversely affect reliability.

<sup>(1)</sup> Refer to reflow profile for soldering conditions for surface mounted devices.

**RECOMMENDED OPERATING CONDITION**

PARAMETER	TEST CONDITION	SYMBOL	MIN.	TYP.	MAX.	UNIT
Operating temperature		$T_{amb}$	- 40		100	$^{\circ}\text{C}$
Supply voltage		$V_{CC}$	4.5		5.5	V
Input current low level		$I_{FL}$	0		250	$\mu\text{A}$
Input current high level		$I_{FH}$	5		15	mA
Output pull up resistor		$R_L$	330		4K	$\Omega$
Logic high enable voltage		$V_{EH}$	2		$V_{CC}$	V
Logic low enable voltage		$V_{EL}$	0.0		0.8	V
Fanout	$R_L = 1\text{ k}\Omega$	N			5	-



<b>ELECTRICAL CHARACTERISTICS</b> ( $T_{amb} = 25\text{ }^{\circ}\text{C}$ , unless otherwise specified)						
PARAMETER	TEST CONDITION	SYMBOL	MIN.	TYP.	MAX.	UNIT
<b>INPUT</b>						
Input forward voltage	$I_F = 10\text{ mA}$	$V_F$	1.1	1.4	1.7	V
Reverse current	$V_R = 5\text{ V}$	$I_R$		0.01	10	$\mu\text{A}$
Input capacitance	$f = 1\text{ MHz}, V_F = 0\text{ V}$	$C_I$		55		pF
<b>OUTPUT</b>						
High level supply current (single channel)	$V_E = 0.5\text{ V}, I_F = 0\text{ mA}$	$I_{CCH}$		4.1	7	mA
	$V_E = V_{CC}, I_F = 0\text{ mA}$	$I_{CCH}$		3.3	6	mA
High level supply current (dual channel)	$I_F = 10\text{ mA}$	$I_{CCH}$		6.5	12	mA
Low level supply current (single channel)	$V_E = 0.5\text{ V}, I_F = 10\text{ mA}$	$I_{CCL}$		4	7	mA
	$V_E = V_{CC}, I_F = 10\text{ mA}$	$I_{CCL}$		3.3	6	mA
Low level supply current (dual channel)	$I_F = 10\text{ mA}$	$I_{CCL}$		6.5	12	mA
High level output current	$V_E = 2\text{ V}, V_O = 5.5\text{ V}, I_F = 250\text{ }\mu\text{A}$	$I_{OH}$		0.002	1	$\mu\text{A}$
Low level output voltage	$V_E = 2\text{ V}, I_F = 5\text{ mA}, I_{OL}(\text{sinking}) = 13\text{ mA}$	$V_{OL}$		0.2	0.6	V
Input threshold current	$V_E = 2\text{ V}, V_O = 5.5\text{ V}, I_{OL}(\text{sinking}) = 13\text{ mA}$	$I_{TH}$		2.4	5	mA
High level enable current		$I_{EH}$		-0.6	-1.6	mA
Low level enable current		$I_{EL}$		-0.8	-1.6	mA
High level enable voltage		$V_{EH}$	2			V
Low level enable voltage		$V_{EL}$			0.8	V

**Note**

- Minimum and maximum values are testing requirements. Typical values are characteristics of the device and are the result of engineering evaluation. Typical values are for information only and are not part of the testing requirements.

<b>SWITCHING CHARACTERISTICS</b>						
PARAMETER	TEST CONDITION	SYMBOL	MIN.	TYP.	MAX.	UNIT
Propagation delay time to high output level	$R_L = 350\text{ }\Omega, C_L = 15\text{ pF}$	$t_{PLH}$	20	48	100	ns
Propagation delay time to low output level	$R_L = 350\text{ }\Omega, C_L = 15\text{ pF}$	$t_{PHL}$	25	50	100	ns
Pulse width distortion	$R_L = 350\text{ }\Omega, C_L = 15\text{ pF}$	$ t_{PHL} - t_{PLH} $		2.9	35	ns
Propagation delay skew	$R_L = 350\text{ }\Omega, C_L = 15\text{ pF}$	$t_{PSK}$		8	40	ns
Output rise time (10 to 90 %)	$R_L = 350\text{ }\Omega, C_L = 15\text{ pF}$	$t_r$		23		ns
Output fall time (90 to 10 %)	$R_L = 350\text{ }\Omega, C_L = 15\text{ pF}$	$t_f$		7		ns
Propagation delay time of enable from $V_{EH}$ to $V_{EL}$	$R_L = 350\text{ }\Omega, C_L = 15\text{ pF}, V_{EL} = 0\text{ V}, V_{EH} = 3\text{ V}$	$t_{ELH}$		12		ns
Propagation delay time of enable from $V_{EL}$ to $V_{EH}$	$R_L = 350\text{ }\Omega, C_L = 15\text{ pF}, V_{EL} = 0\text{ V}, V_{EH} = 3\text{ V}$	$t_{EHL}$		11		ns

**Note**

- Over recommended temperature ( $T_A = -40\text{ }^{\circ}\text{C}$  to  $+100\text{ }^{\circ}\text{C}$ ),  $V_{CC} = 5\text{ V}, I_F = 7.5\text{ mA}$  unless otherwise specified. All typicals at  $T_A = 25\text{ }^{\circ}\text{C}, V_{CC} = 5\text{ V}$ .

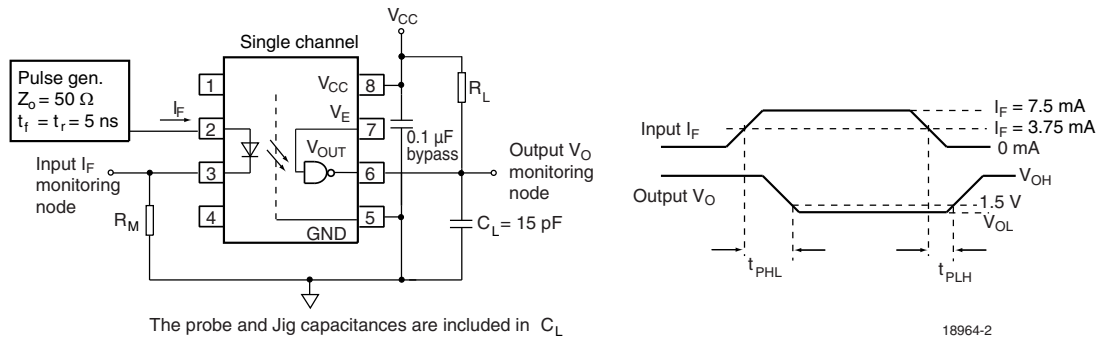

Fig. 1 - Single Channel Test Circuit for  $t_{PLH}$ ,  $t_{PHL}$ ,  $t_r$  and  $t_f$

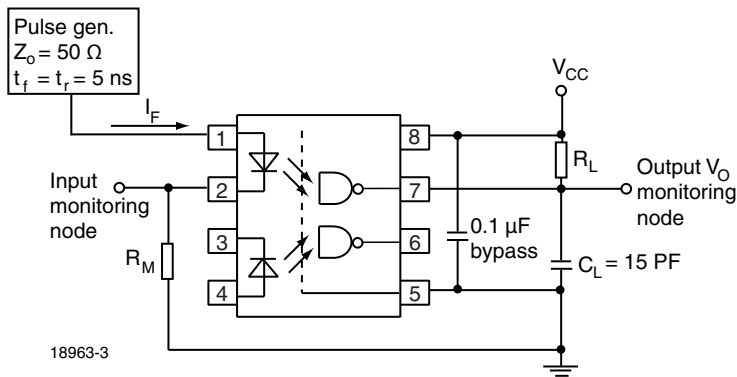

Fig. 2 - Dual Channel Test Circuit for  $t_{PLH}$ ,  $t_{PHL}$ ,  $t_r$  and  $t_f$

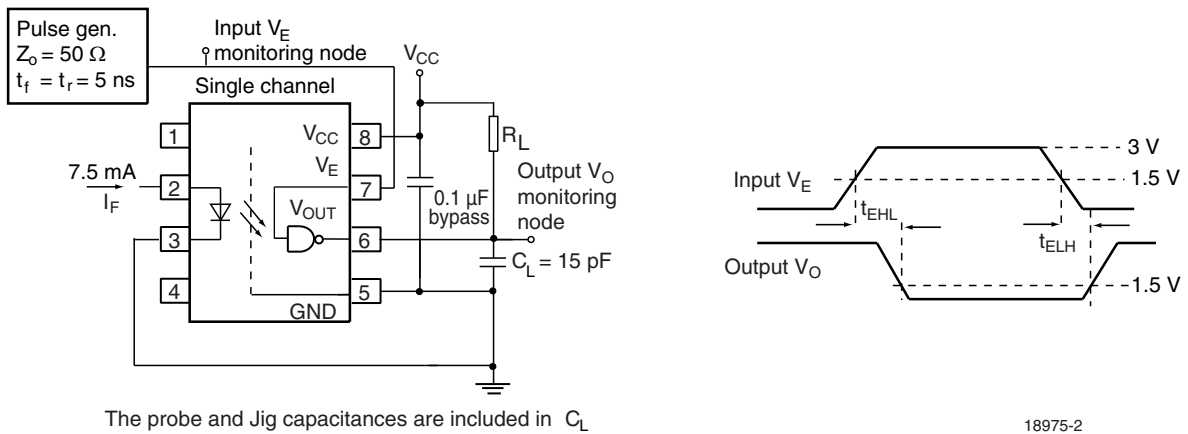

Fig. 3 - Single Channel Test Circuit for  $t_{EHL}$ ,  $t_{ELH}$

COMMON MODE TRANSIENT IMMUNITY						
PARAMETER	TEST CONDITION	SYMBOL	MIN.	TYP.	MAX.	UNIT
Common mode transient immunity (high)	$ V_{CM}  = 10\text{ V}, V_{CC} = 5\text{ V}, I_F = 0\text{ mA}, V_{O(\min)} = 2\text{ V}, R_L = 350\ \Omega, T_{\text{amb}} = 25\text{ }^\circ\text{C}^{(1)}$	$ CM_H $	100			$\text{V}/\mu\text{s}$
	$ V_{CM}  = 50\text{ V}, V_{CC} = 5\text{ V}, I_F = 0\text{ mA}, V_{O(\min)} = 2\text{ V}, R_L = 350\ \Omega, T_{\text{amb}} = 25\text{ }^\circ\text{C}^{(2)}$	$ CM_H $	5000	10 000		$\text{V}/\mu\text{s}$
	$ V_{CM}  = 1\text{ kV}, V_{CC} = 5\text{ V}, I_F = 0\text{ mA}, V_{O(\min)} = 2\text{ V}, R_L = 350\ \Omega, T_{\text{amb}} = 25\text{ }^\circ\text{C}^{(3)}$	$ CM_H $	15 000	25 000		$\text{V}/\mu\text{s}$
Common mode transient immunity (low)	$ V_{CM}  = 10\text{ V}, V_{CC} = 5\text{ V}, I_F = 7.5\text{ mA}, V_{O(\max)} = 0.8\text{ V}, R_L = 350\ \Omega, T_{\text{amb}} = 25\text{ }^\circ\text{C}^{(1)}$	$ CM_L $	100			$\text{V}/\mu\text{s}$
	$ V_{CM}  = 50\text{ V}, V_{CC} = 5\text{ V}, I_F = 7.5\text{ mA}, V_{O(\max)} = 0.8\text{ V}, R_L = 350\ \Omega, T_{\text{amb}} = 25\text{ }^\circ\text{C}^{(2)}$	$ CM_L $	5000	10 000		$\text{V}/\mu\text{s}$
	$ V_{CM}  = 1\text{ kV}, V_{CC} = 5\text{ V}, I_F = 7.5\text{ mA}, V_{O(\max)} = 0.8\text{ V}, R_L = 350\ \Omega, T_{\text{amb}} = 25\text{ }^\circ\text{C}^{(3)}$	$ CM_L $	15 000	25 000		$\text{V}/\mu\text{s}$

**Notes**

- (1) For VO0600T and VO0630T
- (2) For VO0601T and VO0631T
- (3) For VO0611T and VO0661T

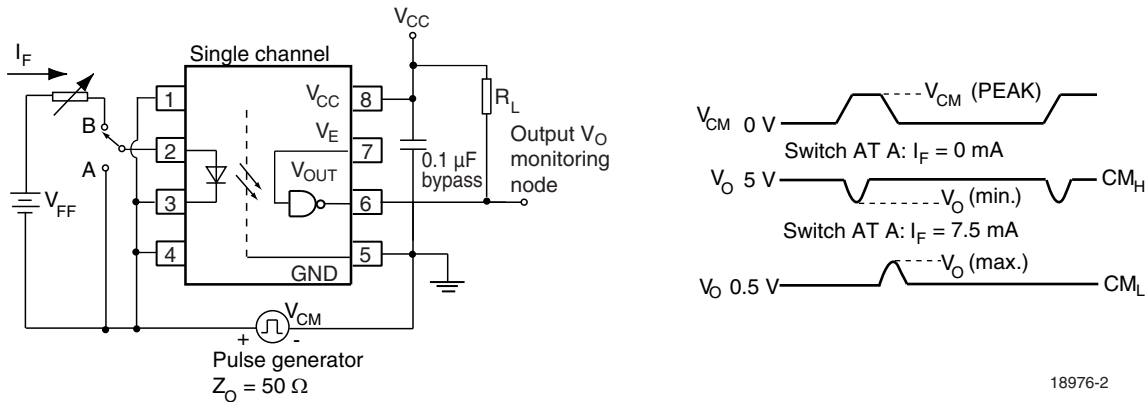

Fig. 4 - Single Channel Test Circuit for Common Mode Transient Immunity

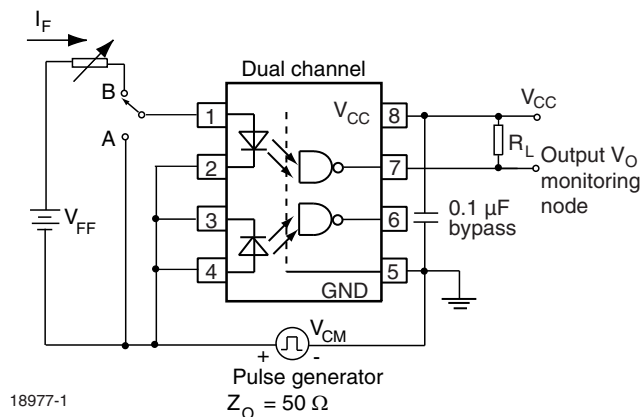

Fig. 5 - Dual Channel Test Circuit for Common Mode Transient Immunity



SAFETY AND INSULATION RATINGS						
PARAMETER	TEST CONDITION	SYMBOL	MIN.	TYP.	MAX.	UNIT
Climatic classification	according to IEC 68 part 1			55/100/21		
Comparative tracking index		CTI	175		399	
$V_{IOTM}$			6000			V
$V_{IORM}$			560			V
$P_{SO}$					350	mW
$I_{SI}$					150	mA
$T_{SI}$					165	°C
Creepage			4			mm
Clearance			4			mm
Insulation thickness			0.2			mm

**Note**

- As per IEC 60747-5-5, 7.4.3.8.1, this optocoupler is suitable for “safe electrical insulation” only within the safety ratings. Compliance with the safety ratings shall be ensured by means of protective circuits.

**TYPICAL CHARACTERISTICS** ( $T_{amb} = 25\text{ }^{\circ}\text{C}$ , unless otherwise specified)

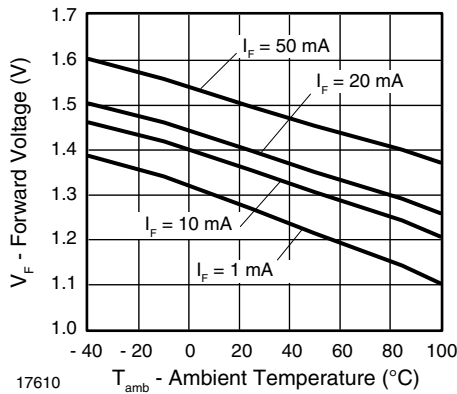

Fig. 6 - Forward Voltage vs. Ambient Temperature

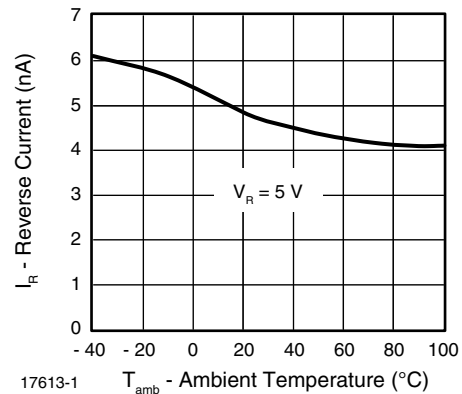

Fig. 8 - Reverse Current vs. Ambient Temperature

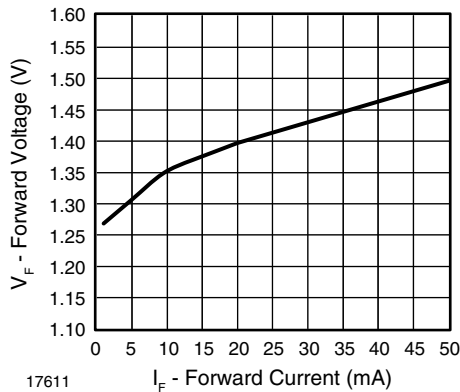

Fig. 7 - Forward Voltage vs. Forward Current

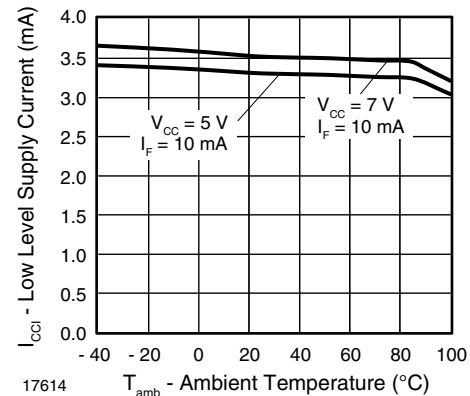

Fig. 9 - Low Level Supply Current vs. Ambient Temperature

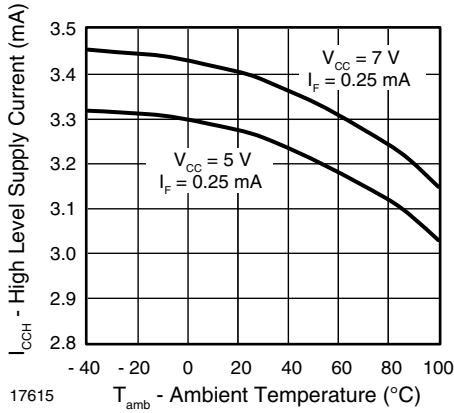

Fig. 10 - High Level Supply Current vs. Ambient Temperature

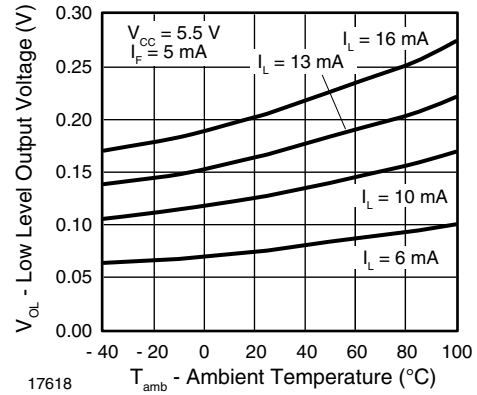

Fig. 13 - Low Level Output Voltage vs. Ambient Temperature

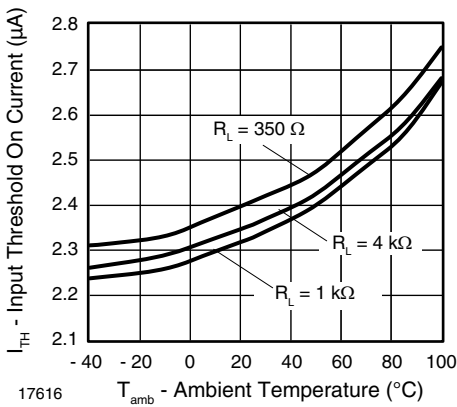

Fig. 11 - Input Threshold On Current vs. Ambient Temperature

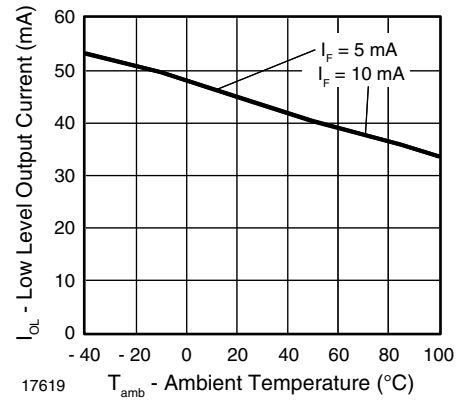

Fig. 14 - Low Level Output Current vs. Ambient Temperature

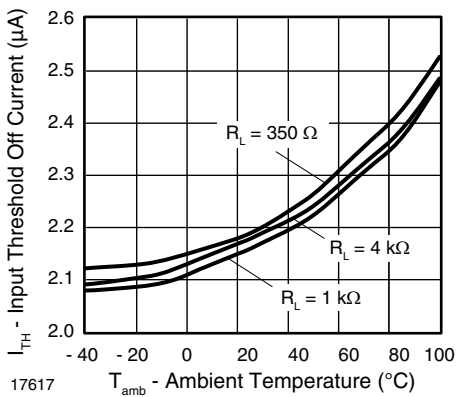

Fig. 12 - Input Threshold Off Current vs. Ambient Temperature

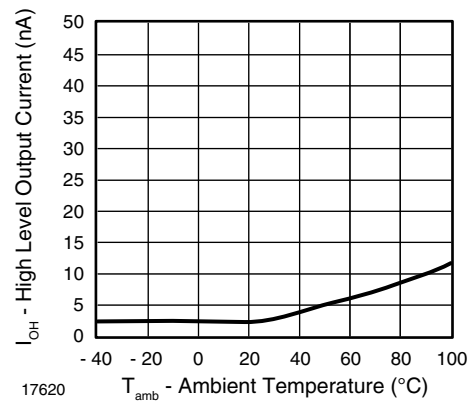

Fig. 15 - High Level Output Current vs. Ambient Temperature

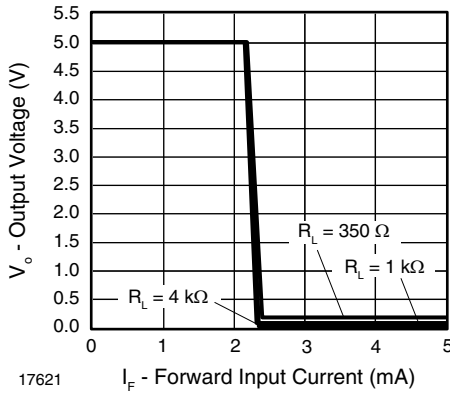

Fig. 16 - Output Voltage vs. Forward Input Current

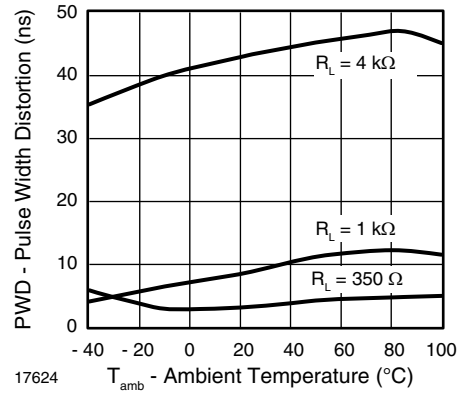

Fig. 19 - Pulse Width Distortion vs. Ambient Temperature

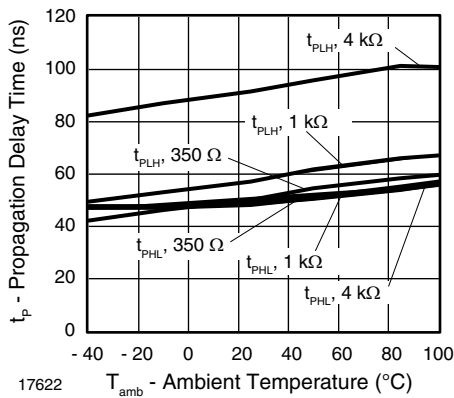

Fig. 17 - Propagation Delay vs. Ambient Temperature

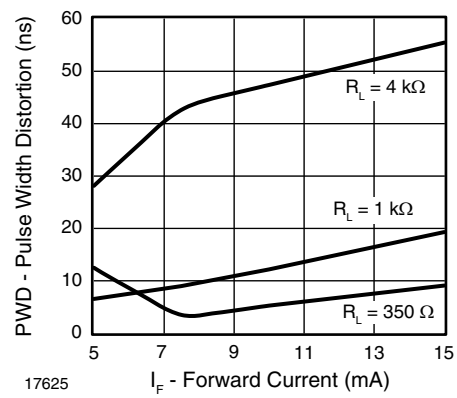

Fig. 20 - Pulse Width Distortion vs. Forward Current

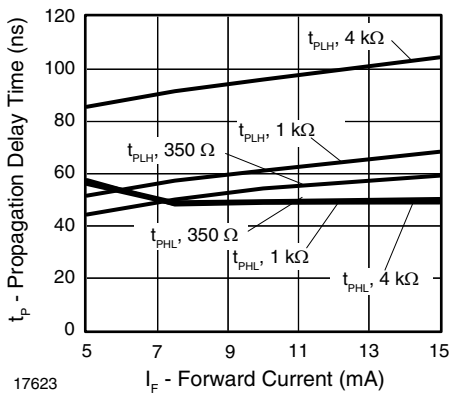

Fig. 18 - Propagation Delay vs. Forward Current

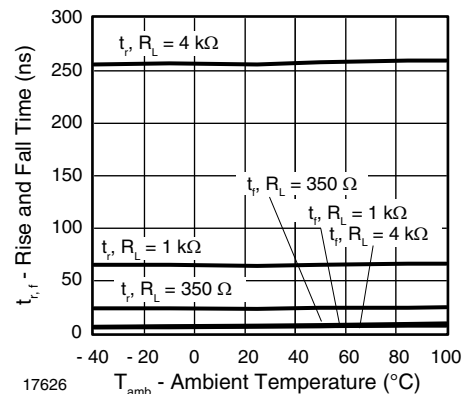

Fig. 21 - Rise and Fall Time vs. Ambient Temperature

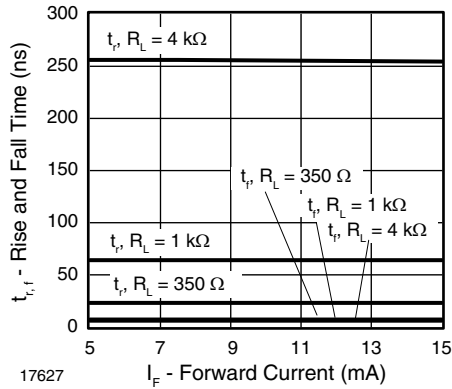

Fig. 22 - Rise and Fall Time vs. Forward Current

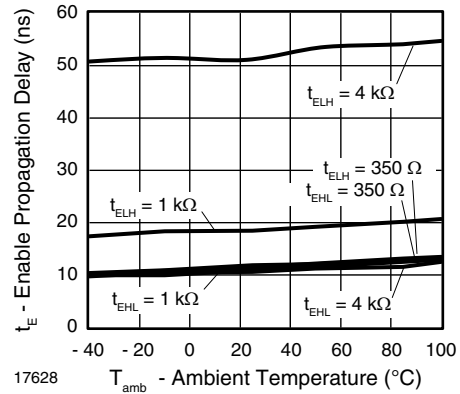
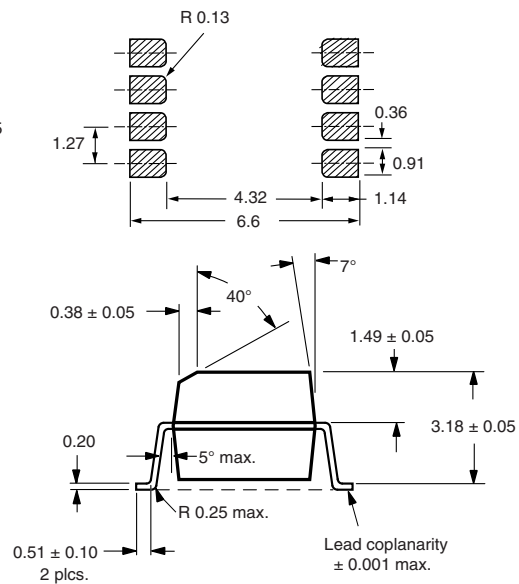
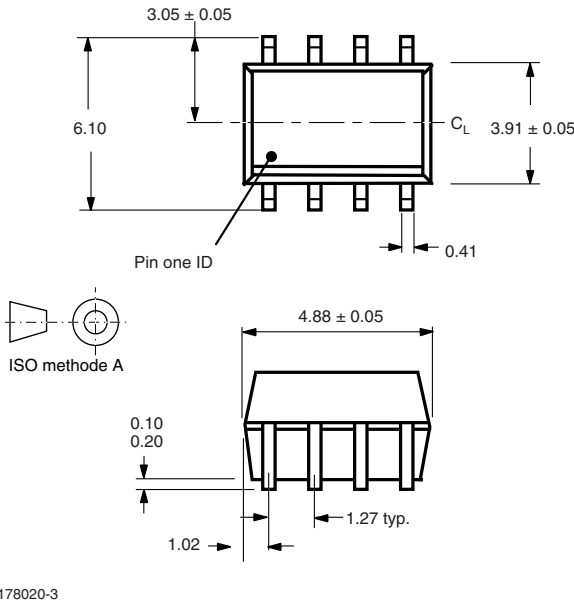
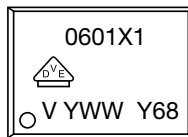

Fig. 23 - Enable Propagation Delay vs. Ambient Temperature

**PACKAGE DIMENSIONS** in millimeters



**PACKAGE MARKING** (example)



**Notes**

- The VDE Logo is only marked on option1 parts.
- Tape and reel suffix (T) is not part of the package marking.

**ESD CAUTION**

This is an ESD (electro static discharge) sensitive device. Electrostatic charges accumulate on the human body and test equipment and can discharge without detection. Therefore, proper ESD precautions are recommended to avoid performance degradation or loss of functionality. ESD withstand voltage of this device is up to 1500 V acc. to JESD22-A114-B.



## Disclaimer

ALL PRODUCT, PRODUCT SPECIFICATIONS AND DATA ARE SUBJECT TO CHANGE WITHOUT NOTICE TO IMPROVE RELIABILITY, FUNCTION OR DESIGN OR OTHERWISE.

Vishay Intertechnology, Inc., its affiliates, agents, and employees, and all persons acting on its or their behalf (collectively, "Vishay"), disclaim any and all liability for any errors, inaccuracies or incompleteness contained in any datasheet or in any other disclosure relating to any product.

Vishay makes no warranty, representation or guarantee regarding the suitability of the products for any particular purpose or the continuing production of any product. To the maximum extent permitted by applicable law, Vishay disclaims (i) any and all liability arising out of the application or use of any product, (ii) any and all liability, including without limitation special, consequential or incidental damages, and (iii) any and all implied warranties, including warranties of fitness for particular purpose, non-infringement and merchantability.

Statements regarding the suitability of products for certain types of applications are based on Vishay's knowledge of typical requirements that are often placed on Vishay products in generic applications. Such statements are not binding statements about the suitability of products for a particular application. It is the customer's responsibility to validate that a particular product with the properties described in the product specification is suitable for use in a particular application. Parameters provided in datasheets and/or specifications may vary in different applications and performance may vary over time. All operating parameters, including typical parameters, must be validated for each customer application by the customer's technical experts. Product specifications do not expand or otherwise modify Vishay's terms and conditions of purchase, including but not limited to the warranty expressed therein.

Except as expressly indicated in writing, Vishay products are not designed for use in medical, life-saving, or life-sustaining applications or for any other application in which the failure of the Vishay product could result in personal injury or death. Customers using or selling Vishay products not expressly indicated for use in such applications do so at their own risk and agree to fully indemnify and hold Vishay and its distributors harmless from and against any and all claims, liabilities, expenses and damages arising or resulting in connection with such use or sale, including attorneys fees, even if such claim alleges that Vishay or its distributor was negligent regarding the design or manufacture of the part. Please contact authorized Vishay personnel to obtain written terms and conditions regarding products designed for such applications.

No license, express or implied, by estoppel or otherwise, to any intellectual property rights is granted by this document or by any conduct of Vishay. Product names and markings noted herein may be trademarks of their respective owners.

## Material Category Policy

**Vishay Intertechnology, Inc. hereby certifies that all its products that are identified as RoHS-Compliant fulfill the definitions and restrictions defined under Directive 2011/65/EU of The European Parliament and of the Council of June 8, 2011 on the restriction of the use of certain hazardous substances in electrical and electronic equipment (EEE) - recast, unless otherwise specified as non-compliant.**

**Please note that some Vishay documentation may still make reference to RoHS Directive 2002/95/EC. We confirm that all the products identified as being compliant to Directive 2002/95/EC conform to Directive 2011/65/EU.**