

Double wheel

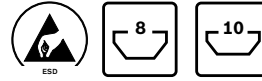

- ▶ Attractive-looking double wheel for light applications
- ▶ Made of oil-resistant material
- ▶ Double wheel with lock
- ▶ Double wheel D50-D10 for insertion in the central hole with a diameter of 10 mm
- ▶ Double wheel D50-M8 for bolting into the profile slot

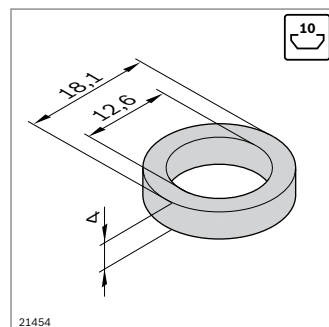
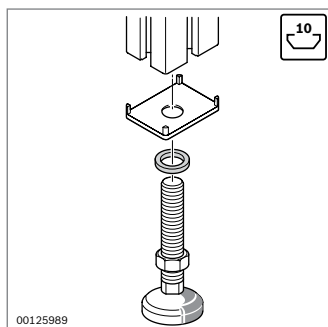
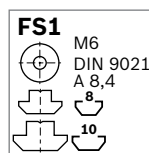
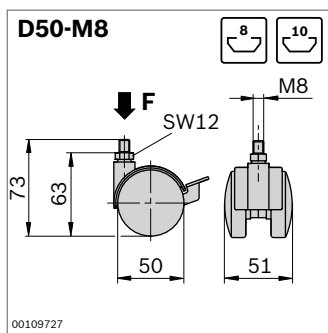
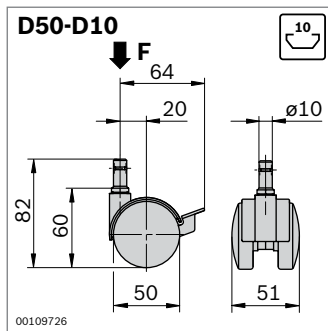

Double wheel	F (N)	ESD		No.
D50-D10	400		4	3 842 515 457
	400		4	3 842 515 459

¹⁾ Conduction resistance $\leq 10^6 \Omega$

Material: Housing, wheel, lock: PA
 Running surface: PU (not with ESD version)
 Fastening material: steel; galvanized

Double wheel	F (N)	ESD		No.	FS
D50-M8	400		4	3 842 535 669	FS1
	400		4	3 842 535 670	FS1

¹⁾ Conduction resistance $\leq 10^6 \Omega$

Material: Housing, wheel, lock: PA
 Running surface: PU (not with ESD version)
 Fastening material: steel; galvanized

Bearing ring

- ▶ For cover caps with hole in the sizes 40x40, 45x45, 50x50 and 60x60
- ▶ For M12 threads
- ▶ To protect the caps when tightening accessories

Bearing ring		No.
	100	3 842 555 653

Material: diecast zinc