

PARATHOM® MR16 35 36° 827 GU5.3

Product description



Product Offering

Type reference	Wattage	CCT	lm	CRI
MR16 35 36°	6.8W	2700K	350lm	>80

- Compact mains voltage LED reflector lamp in MR16 shape
- GU5.3 base for easy replacement
- Equipped with high-efficiency patented LEDs, quality assured
- Shockproof and vibration-proof

1. Key Features and Benefits

- LED MR16 lamp as replacement for Decostar 51 35W lamp
- Voltage: 12V
- GU5.3 base
- Warm white color (2700K)
- conform to 1194/2012 EU
- reduces energy consumption > 80%
- Energy Class A
- shock-proof and vibration-proof
- 15.000 hours lifetime
- Non dimmable¹
- UV and NIR radiation free
- Mercury free
- 4 years Osram Guarantee²

¹ See www.osram.com/dim

² See www.osram.com/guarantee

2. Common Characteristics³

Average lifetime ⁴		Switching cycles (30s on, 30s off)		Casing material	Starting time	Warm up time for 60% light	Power factor
15,000h		>100,000		metal	<0.5s	<1s	≥0.9
Mercury max.	Base Type	Length	Diameter	Weight	Tc temperature max. ⁵	Nominal current (12V/50Hz)	Beam angle
0.0mg	GU5,3	48mm	50mm	55g	95°C	600mA	36°

3. Characteristic Range³

Type reference	Wattage	Luminous flux	Luminous intensity	Correlated colour temperature	SDCM	CRI
MR16 35 36°	6.8W	350lm	800cd	2700	>6	>80

4. Mounting information

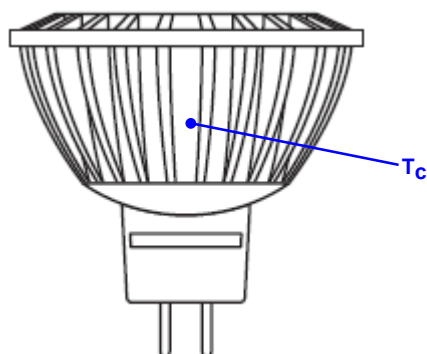

³ Typical values. All the technical parameters apply to the entire lamp. In view of the complex manufacturing process for light emitting diodes, the typical values given above for the technical LED parameters are merely statistical values that do not necessarily correspond to the actual technical parameters of an individual product; individual products may vary from the typical values.

⁴ The average lifetime of LED lamps is defined as the number of hours when the light output of 50% of a large group of identical lamps goes below 70% of its initial luminous flux (L70B50, IEC60969). The lifetime is estimated at room temperature (25°C), free air burning, base up burning position and at rated voltage. To achieve a full lifetime a good heat exchange for the electronic components is required.

⁵ The Tc is defined as the highest permissible temperature which may occur on the outer surface of the LED lamp (in the indicated position) under normal operating conditions and at the rated voltage/current/power or the maximum of the rated voltage/current/power range (DIN EN 62031: 2009-01)

5. Disposal information

WEEE-lamps can be returned at specific collection points.
LED lamps have to be disposed as special waste.



6. Application Information

Applications

- hotels
- restaurant
- commercial areas
- residentials
- art galleries and museum
- office space

Application Notes

1. Suitable for indoor application.
2. For outdoor applications and operation in damp locations special approved fixture are required.
3. Input voltage: AC: 12V
4. Operating temperature range between -20°C and 40°C

7. Cost savings: example

Reference product description	Similar halogen product	Watts saved	Cost saved after 2 year	Cost saved after 5 years	Cost saved after 15 years
MR16 35	DECOSTAR 51 35W	28W	6,40€	26€	87€

Based on the assumption of 2.7hours/day on and an energy cost of 0.21€/kWh

8. Ordering Guide

Type reference	Product Number – 1pcs	Product Number – 1 shipping unit	Number of pcs / ship. unit
PARATHOM® MR16 35 36°	4052899910782	4052899910799	10

9. Lamp conformity

2004/108/EC Electromagnetic compatibility (EMC)

2011/65/EC Restriction of the use of certain hazardous substances in electrical and electronic equipment (RoHS)

1907/2006 Registration, Evaluation, Authorisation and Restriction of Chemicals (REACH Regulation)

2002/96/EC Waste Electrical and Electronic Equipment Directive (WEEE)

EN 62471 Photobiological safety of lamps and lamp systems

IEC/TR 62471-2 Photobiological safety of lamps and lamp systems - Part 2: Guidance on manufacturing requirements relating to non-laser optical radiation safety

EN 55015 Limits and methods of measurement of radio disturbance

EN 61000-3-2 Electromagnetic compatibility – Limits for harmonic current emission

EN 61000-3-3 Electromagnetic compatibility – Limitation of voltage changes, voltage fluctuations, flicker in public low voltage supply systems

FN61547 Electromagnetic compatibility immunity requirements