

D3G250-EF41-01

# EC centrifugal fan

forward curved, dual inlet  
with housing (flange)



## ebm-papst Mulfingen GmbH & Co. KG

Bachmühle 2 · D-74673 Mulfingen

Phone +49 7938 81-0

Fax +49 7938 81-110

info1@de.ebmpapst.com

www.ebmpapst.com

Limited partnership · Headquarters Mulfingen  
County court Stuttgart · HRA 590344

General partner Elektrobau Mulfingen GmbH · Headquarters Mulfingen  
County court Stuttgart · HRB 590142



## Nominal data

Type	D3G250-EF41-01	
Motor	M3G112-GA	
Phase		3~
Nominal voltage	VAC	400
Nominal voltage range	VAC	380 .. 480
Frequency	Hz	50/60
Type of data definition		ml
Speed	min <sup>-1</sup>	1500
Power input	W	1000
Current draw	A	1.7
Min. back pressure	Pa	100
Min. ambient temperature	°C	-25
Max. ambient temperature	°C	40

ml = Max. load · me = Max. efficiency · fa = Running at free air · cs = Customer specs · cu = Customer unit  
Subject to alterations

## Data according to ErP directive

Installation category	A
Efficiency category	Static
Variable speed drive	Yes
Specific ratio*	1.01

\* Specific ratio =  $1 + p_b / 100\,000\text{ Pa}$

		Actual	Request 2013	Request 2015
Overall efficiency $\eta_{es}$	%	48	29.2	36.2
Efficiency grade N		55.8	37	44
Power input $P_{ed}$	kW	0.59		
Air flow $q_v$	m <sup>3</sup> /h	1805		
Pressure increase $p_{fs}$	Pa	515		
Speed n	min <sup>-1</sup>	1660		

Data definition with optimum efficiency. LU-108913  
The ErP data is determined using a motor-impeller combination in a standardised measurement configuration.



# EC centrifugal fan

forward curved, dual inlet  
with housing (flange)

## Technical features

<b>Mass</b>	15.8 kg
<b>Size</b>	250 mm
<b>Surface of rotor</b>	Coated in black
<b>Material of electronics housing</b>	Die-cast aluminum
<b>Material of impeller</b>	Sheet steel, hot-galvanised
<b>Housing material</b>	Sheet steel, hot-galvanised
<b>Motor suspension</b>	Motor anti-vibration mounted on one side via brackets
<b>Direction of rotation</b>	Clockwise, seen on rotor
<b>Type of protection</b>	IP 54
<b>Insulation class</b>	"B"
<b>Humidity class</b>	F4-1
<b>Max. permissible ambient motor temp. (transp./ storage)</b>	+80 °C
<b>Min. permissible ambient motor temp. (transp./storage)</b>	-40 °C
<b>Mounting position</b>	Shaft horizontal
<b>Condensate discharge holes</b>	None
<b>Operation mode</b>	S1
<b>Motor bearing</b>	Ball bearing
<b>Technical features</b>	<ul style="list-style-type: none"> <li>- PFC, passive</li> <li>- Control input 0-10 VDC / PWM</li> <li>- Output 10 VDC, max. 10 mA</li> <li>- Alarm relay</li> <li>- Line undervoltage / phase failure detection</li> <li>- Motor current limit</li> <li>- Over-temperature protected electronics / motor</li> <li>- Soft start</li> </ul>
<b>EMC interference immunity</b>	Acc. to EN 61000-6-2 (industrial environment)
<b>EMC harmonics</b>	Acc. to EN 61000-3-2/3
<b>EMC interference emission</b>	Acc. to EN 61000-6-3 (household environment)
<b>Touch current acc. IEC 60990 (measuring network Fig. 4, TN system)</b>	<= 3.5 mA
<b>Motor protection</b>	Thermal overload protector (TOP) wired internally
<b>Cable exit</b>	Variable
<b>Protection class</b>	I (if protective earth is connected by customer)
<b>Product conforming to standard</b>	CE
<b>Approval</b>	EAC; CCC



D3G250-EF41-01

# EC centrifugal fan

forward curved, dual inlet  
with housing (flange)

## Product drawing

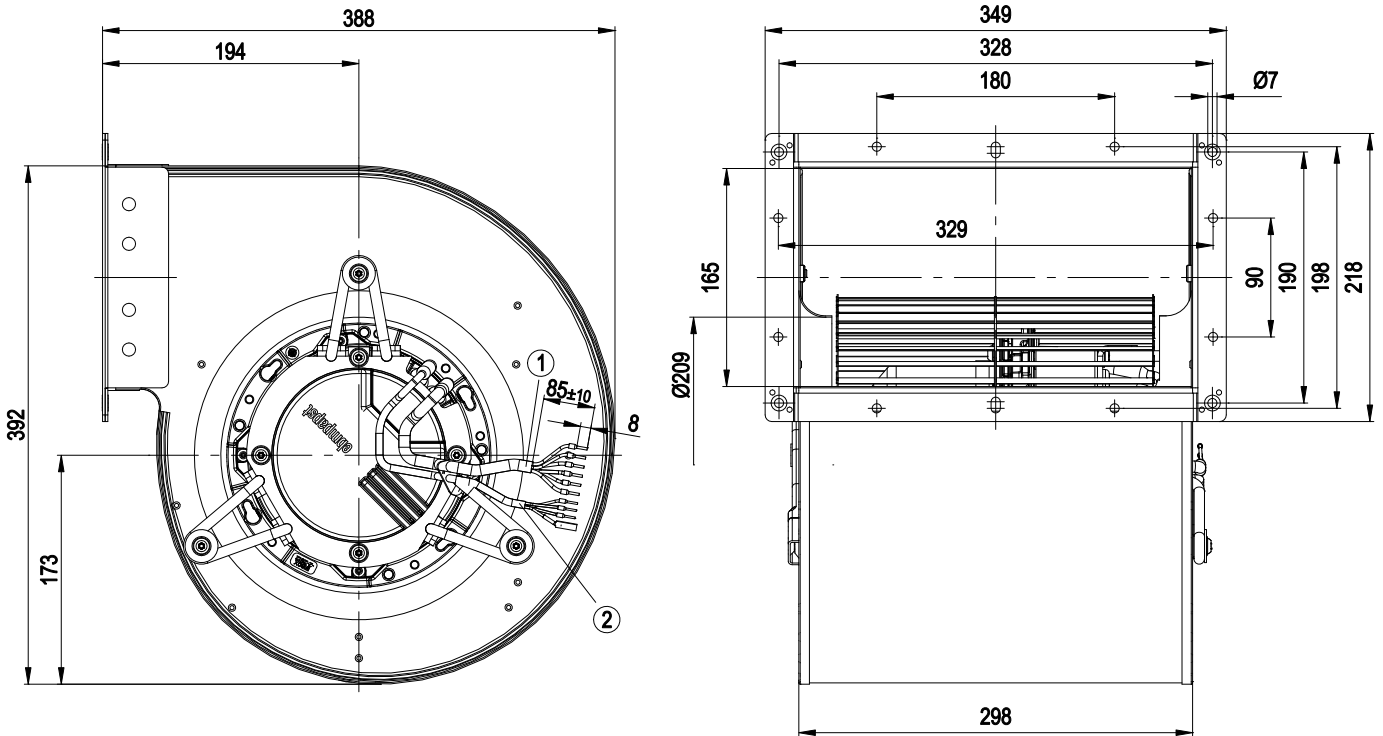

Cable length from electronics enclosure: 800+20 mm

1	Connection line AWG18, 6x crimped core-end sleeves
2	Connection line AWG22, 3 x crimped core-end sleeves



# EC centrifugal fan

forward curved, dual inlet  
with housing (flange)

## Connection screen

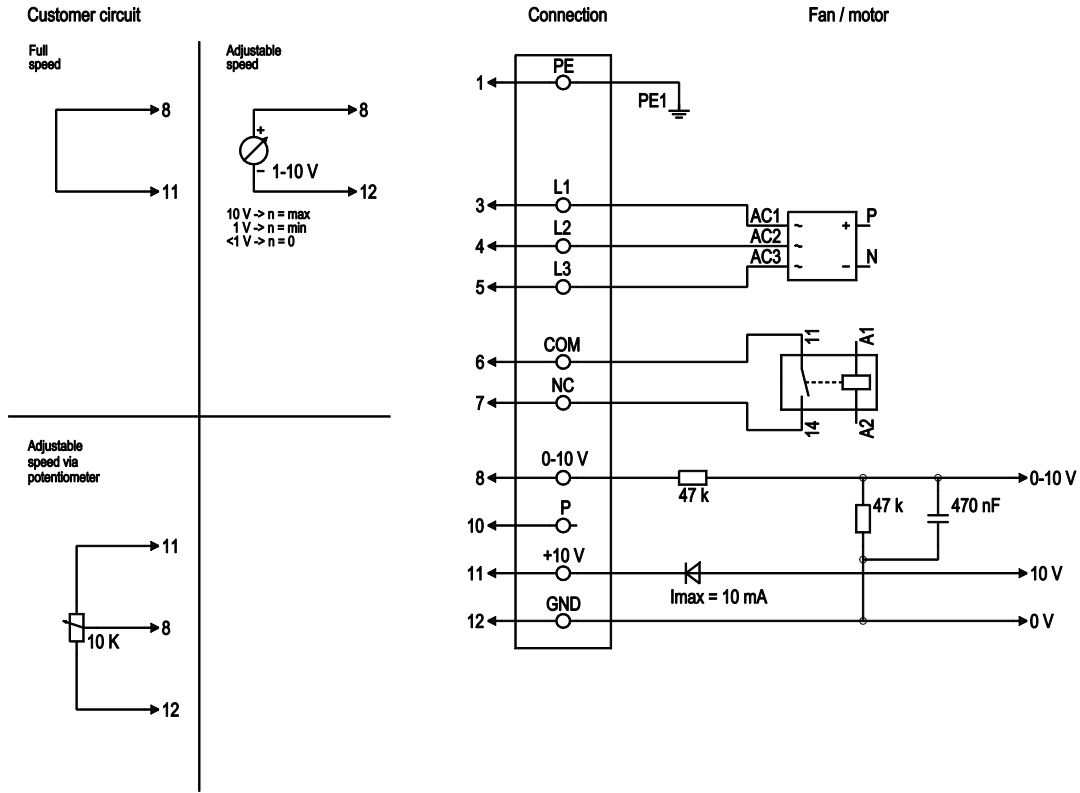

No.	Conn.	Designation	Colour	Function / assignment
1	1	PE	green/yellow	Ground wire
1	3	L1	black	Supply voltage, 50/60 Hz
1	4	L2	black	Supply voltage, 50/60 Hz
1	5	L3	black	Supply voltage, 50/60 Hz
1	6	COM	white 1	Floating status message contact, normally closed connection (2 A, max. 250 VAC, min. 10 mA, AC1)
1	7	NC	white 2	Floating status message contact, normally closed connection
2	8	0-10 V	yellow	Control input, set value 0-10 VDC, impedance 100 kΩ, SELV
2	10	P	orange	Do not use
2	11	+10 V	red	Voltage output 10 VDC (+/-3%), max. 10 mA, supply voltage for external devices (e.g. potentiometer), SELV
2	12	GND	blue	Reference mass for control interface, SELV



## Charts: Air flow 50 Hz

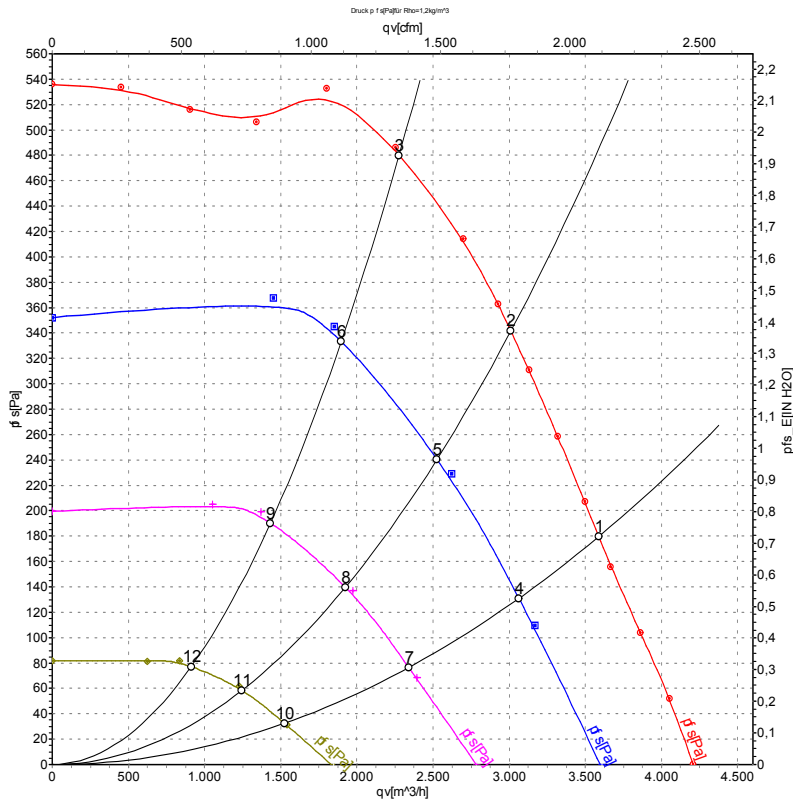

Measurement: LU-108913  
 Measurement: LU-109037  
 Measurement: LU-109038  
 Measurement: LU-109039

Air performance measured as per ISO 5801 Installation category A. For detailed information on the measuring set-up, please contact ebm-papst. Suction-side noise levels: L<sub>wA</sub> measured as per ISO 13347 / L<sub>pA</sub> measured with 1m distance to fan axis. The values given are valid under the measuring conditions mentioned above and may vary according to the actual installation situation. With any deviation from the standard set-up, the specific values have to be checked and reviewed with the unit installed.

## Measured values

	U	f	n	P <sub>ed</sub>	I	L <sub>pA<sub>in</sub></sub>	L <sub>wA<sub>in</sub></sub>	L <sub>wA<sub>out</sub></sub>	q <sub>v</sub>	p <sub>fs</sub>
	V	Hz	min <sup>-1</sup>	W	A	dB(A)	dB(A)	dB(A)	m <sup>3</sup> /h	Pa
1	400	50	1500	1000	1.70	78	86	88	3590	180
2	400	50	1565	883	1.41	75	83	85	3010	340
3	400	50	1630	708	1.16	73	81	82	2275	480
4	400	50	1280	603	1.02	73	82	83	3065	132
5	400	50	1315	507	0.90	70	79	81	2525	244
6	400	50	1360	402	0.76	68	76	78	1895	338
7	400	50	985	288	0.58	67	76	77	2340	77
8	400	50	1010	242	0.50	64	72	73	1925	142
9	400	50	1035	187	0.40	60	69	71	1435	193
10	400	50	650	92	0.24	56	64	65	1525	33
11	400	50	655	81	0.21	52	61	62	1245	60
12	400	50	665	66	0.19	48	58	59	910	78

U = Supply voltage · f = Frequency · n = Speed · P<sub>ed</sub> = Power input · I = Current draw · L<sub>pA<sub>in</sub></sub> = Sound pressure level inlet side · L<sub>wA<sub>in</sub></sub> = Sound power level inlet side · L<sub>wA<sub>out</sub></sub> = Sound power level outlet side  
 q<sub>v</sub> = Air flow · p<sub>fs</sub> = Pressure increase

