

- 1
- 2
- 3
- 4
- 5
- 6
- 7
- 8
- 9
- 10
- 11
- 12
- 13
- 14
- 15
- RH

MATERIAL

High-strength, reinforced phenolic based (PF) Duroplast, black colour, glossy finish.

RING

Matte anodised aluminium.
(ELESA Original design - Reg. U.S. Pat. & TM Off.)

STANDARD EXECUTIONS

- See table for maximum permissible boring diameters d' and d'' .
- **VDN.FP-A**: without handle, black-oxide steel hub, H7 reamed hole.
 - **VDN.FP+I-A**: with revolving handle I.301+x in Duroplast. Black-oxide steel hub, H7 reamed hole.
 - **VDN.FP+IR-A**: with fold-away handle IR.407 in Duroplast. Black-oxide steel hub, H7 reamed hole.
 - **VDN.FP+IRS-A**: with automatic fold-away safety handle "Fold-O-matic"® type IRS.820 in technopolymer. Black-oxide steel hub, H7 reamed hole.
 - **VDN.FP**: without handle, black-oxide steel hub, not drilled.
 - **VDN.FP+I**: with revolving handle I.301+x in Duroplast. Black-oxide steel hub, not drilled.
 - **VDN.FP+IR**: with fold-away handle IR.407 in Duroplast. Black-oxide steel hub, not drilled.
 - **VDN.FP+IRS**: with automatic fold-away safety handle "Fold-O-matic"® IRS.820 in technopolymer. Black-oxide steel hub, not drilled.

ACCESSORIES ON REQUEST

Axial retaining washer in black-oxide steel GN 184.

SPECIAL EXECUTIONS ON REQUEST

- Hub with hole and keyway in compliance with DIN 6885/1 tolerance P9.
- To order the handwheel with keyway complete code and description with the index -K (i.e. 73650-10-K VDN.50 FP-A-10-K).
- Handwheels with incorporated balancing counterweights.

ERGONOMY

The rim with internal rear scallops makes the grip and the manoeuvre of the handwheel easier.





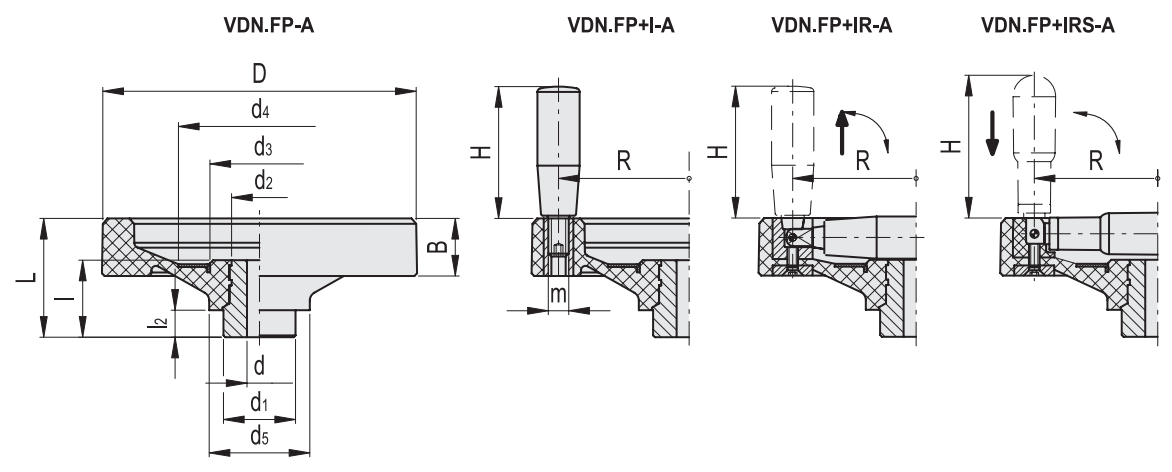
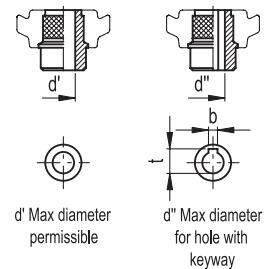















ELESA Original design



















Operating elements



VDN.FP-A

Code	Description	D	dH7	L	B	d1	d2	d3	d4	d5	l	l2	d'	d''	t	b	C# [Nm]	L# [J]		
73650-10	VDN.50 FP-A-10	50	10	22	12	16	16	-	25	26	19	9	12	10	11.4	3	55	3	51	
73670-10	VDN.63 FP-A-10	63	10	28	13	20	20	-	31	28	24	10	13	11	12.8	4	75	4	100	
73690-10	VDN.80 FP-A-10	80	10	31	14	20	18	28	43	30	28	10	13	11	12.8	4	120	5	130	
73690-12	VDN.80 FP-A-12	80	12	31	14	20	18	28	43	30	28	10	13	11	12.8	4	120	5	125	
73709-10	VDN.100 FP-A-10	100	10	40	15	24	22	35	54	39	36	12	16	13	15.3	5	150	6	240	
73709-12	VDN.100 FP-A-12	100	12	40	15	24	22	35	54	39	36	12	16	13	15.3	5	150	6	232	
73719-12	VDN.125 FP-A-12	125	12	44	15	32	26.5	44	70	46	38	15	20	16	18.3	5	300	8	362	
73719-14	VDN.125 FP-A-14	125	14	44	15	32	26.5	44	70	46	38	15	20	16	18.3	5	300	8	350	
73723-14	VDN.140 FP-A-14	140	14	46	19	32	26.5	44	70	48	38	15	20	16	18.3	5	350	10	429	
73729-14	VDN.150 FP-A-14	150	14	49	18	32	26.5	44	70	48	38	15	20	16	18.3	5	400	14	478	
73729-16	VDN.150 FP-A-16	150	16	49	18	32	26.5	44	70	48	38	15	20	16	18.3	5	400	14	466	
73739-16	VDN.175 FP-A-16	175	16	54	19	40	33	55	90	56	43	15	26	22	24.8	6	500	16	710	
73739-18	VDN.175 FP-A-18	175	18	54	19	40	33	55	90	56	43	15	26	22	24.8	6	500	16	714	
73749-18	VDN.200 FP-A-18	200	18	58	21	40	33	55	90	60	43	15	26	22	24.8	6	600	18	1096	
73749-20	VDN.200 FP-A-20	200	20	58	21	40	33	55	90	60	43	15	26	22	24.8	6	600	18	1088	
73769-22	VDN.250 FP-A-22	249	22	65	25	49	40	66	110	70	44	15	35	27	30.3	8	1000	28	1575	
73780-26	VDN.300 FP-A-26	301	26	75	25	58	58	94	148	82	56	18	42	38	41.3	10	1100	35	2755	





VDN.FP+I-A

Code	Description	D	dH7	L	B	d1	d2	d3	d4	d5	l	l2	H	m	R	d'	d''	t	b	C# [Nm]	L# [J]		
73651-10	VDN.50 FP+I-A-10	50	10	22	12	16	16	-	25	26	19	9	28	M6	19	12	10	11.4	3	55	3	64	
73671-10	VDN.63 FP+I-A-10	63	10	28	13	20	20	-	31	28	24	10	40	M6	24	13	11	12.8	4	75	4	131	
73691-10	VDN.80 FP+I-A-10	80	10	31	14	20	18	28	43	30	28	10	40	M6	32	13	11	12.8	4	120	5	160	
73691-12	VDN.80 FP+I-A-12	80	12	31	14	20	18	28	43	30	28	10	40	M6	32	13	11	12.8	4	120	5	157	
73710-10	VDN.100 FP+I-A-10	100	10	46	21	24	20	35	54	39	33.5	12	50	M6	39	16	13	15.3	5	150	6	361	
73710-12	VDN.100 FP+I-A-12	100	12	46	21	24	20	35	54	39	33.5	12	50	M6	39	16	13	15.3	5	150	6	358	
73720-12	VDN.125 FP+I-A-12	125	12	57	28	32	26.5	44	70	46	38	15	65	M8	50	20	16	18.3	5	300	8	568	
73720-14	VDN.125 FP+I-A-14	125	14	57	28	32	26.5	44	70	46	38	15	65	M8	50	20	16	18.3	5	300	8	565	
73724-14	VDN.140 FP+I-A-14	140	14	55	28	32	26.5	44	70	48	38	15	65	M8	58	20	16	18.3	5	350	10	578	
73730-14	VDN.150 FP+I-A-14	150	14	61	30	32	26.5	50	80	48	38	15	65	M8	62	20	16	18.3	5	400	14	737	
73730-16	VDN.150 FP+I-A-16	150	16	61	30	32	26.5	50	80	48	38	15	65	M8	62	20	16	18.3	5	400	14	734	
73740-16	VDN.175 FP+I-A-16	175	16	66	32	40	33	55	90	56	43	15	80	M10	72.5	26	22	24.8	6	500	16	1089	
73740-18	VDN.175 FP+I-A-18	175	18	66	32	40	33	55	90	56	43	15	80	M10	72.5	26	22	24.3	6	500	16	1087	
73750-18	VDN.200 FP+I-A-18	200	18	68	32	40	33	55	90	60	43	15	90	M10	82	26	22	24.8	6	600	18	1314	
73750-20	VDN.200 FP+I-A-20	200	20	68	32	40	33	55	90	60	43	15	90	M10	82	26	22	24.8	6	600	18	1308	
73760-20	VDN.225 FP+I-A-20	225	20	71	33	49	40	66	110	66	44.5	15	90	M10	94	34	27	30.3	8	900	25	1708	
73760-22	VDN.225 FP+I-A-22	225	22	71	33	49	40	66	110	66	44.5	15	90	M10	94	34	27	30.3	8	900	25	1702	
73770-22	VDN.250 FP+I-A-22	249	22	76	36	49	40	66	110	70	44.5	15	90	M10	106	35	27	30.3	8	1000	28	2100	
73770-24	VDN.250 FP+I-A-24	249	24	76	36	49	40	66	110	70	44.5	15	90	M10	106	35	27	30.3	8	1000	28	2097	
73781-26	VDN.300 FP+I-A-26	301	26	87	36	58	58	94	148	82	56	18	90	M10	132	42	38	41.3	10	1100	35	3026	

VDN.FP+IR-A

Code	Description	D	dH7	L	B	d1	d2	d3	d4	d5	l	l2	H	R	d'	d''	t	b	C# [Nm]	L# [J]		
73711-10	VDN.100 FP+IR-A-10	100	10	51	26	24	20	35	54	39	33.5	12	56	37	16	13	15.3	5	150	6	427	
73721-12	VDN.125 FP+IR-A-12	125	12	57	28	32	26.5	44	70	46	38	15	56	48	20	16	18.3	5	300	8	596	
73731-14	VDN.150 FP+IR-A-14	150	14	61	30	32	26.5	50	80	48	38	15	65	57	20	16	18.3	5	400	14	803	
73741-16	VDN.175 FP+IR-A-16	175	16	66	32	40	33	55	90	56	43	15	80	68	26	22	24.8	6	500	16	1147	
73751-20	VDN.200 FP+IR-A-20	200	20	68	32	40	33	55	90	60	43	15	90	76.5	26	22	24.8	6	600	18	1462	
73761-20	VDN.225 FP+IR-A-20	225	20	71	33	49	40	66	110	66	44.5	15	90	88	34	27	30.3	8	900	25	1856	
73771-22	VDN.250 FP+IR-A-22	249	22	76	36	49	40	66	110	70	44.5	15	90	100	35	27	30.3	8	1000	28	2248	
73782-26	VDN.300 FP+IR-A-26	301	26	87	36	58	58	94	148	82	56	18	90	124	42	38	41.3	10	1100	35	3212	

VDN.FP+IRS-A

Code	Description	D	dH7	L	B	d1	d2	d3	d4	d5	l	l2	H	R	d'	d''	t	b	C# [Nm]	L# [J]		
73732-14	VDN.150 FP+IRS-A-14	150	14	61	30	32	26.5	50	80	48	38	15	65	57	20	16	18.3	5	400	14	652	
73742-16	VDN.175 FP+IRS-A-16	175	16	66	32	40	33	55	90	56	43	15	80	68	26	22	24.8	6	500	16	938	
73752-20	VDN.200 FP+IRS-A-20	200	20	68	32	40	33	55	90	60	43	15	90	74.5	26	22	24.8	6	600	18	1252	
73762-20	VDN.225 FP+IRS-A-20	225	20	71	33	49	40	66	110	66	44.5	15	90	86	34	27	30.3	8	900	25	1496	
73772-22	VDN.250 FP+IRS-A-22	249	22	76	36	49	40	66	110	70	44.5	15	90	98	35	27	30.3	8	1000	28	1852	

For maximum applicable torque (C) and impact strength (L) see Technical data on page A-3.

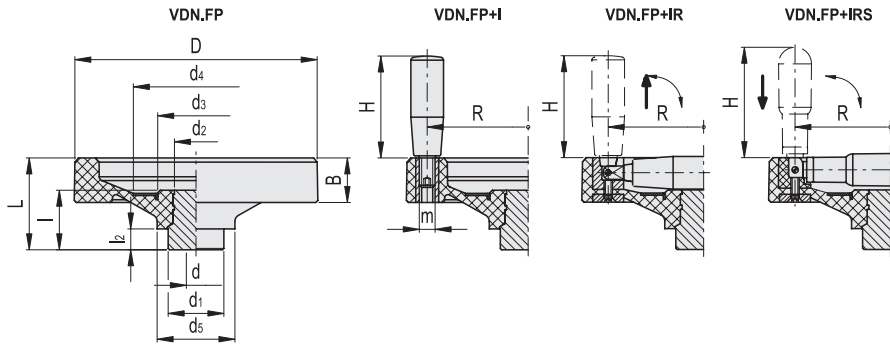

VDN.FP

Code	Description	D	L	B	d1	d2	d3	d4	d5	l	l2	d'	d''	t	b	C# [Nm]	L# [J]	Δ
73650	VDN.50 FP	50	22	12	16	16	-	25	26	19	9	12	10	11.4	3	55	3	61
73670	VDN.63 FP	63	28	13	20	20	-	31	28	24	10	13	11	12.8	4	75	4	112
73690	VDN.80 FP	80	31	14	20	18	28	43	30	28	10	13	11	12.8	4	120	5	142
73709	VDN.100 FP	100	40	15	24	22	35	54	39	36	12	16	13	15.3	5	150	6	260
73719	VDN.125 FP	125	44	15	32	26.5	44	70	46	38	15	20	16	18.3	5	300	8	394
73723	VDN.140 FP	140	46	19	32	26.5	44	70	48	38	15	20	16	18.3	5	350	10	476
73729	VDN.150 FP	150	49	18	32	26.5	44	70	48	38	15	20	16	18.3	5	400	14	522
73739	VDN.175 FP	175	54	19	40	33	55	90	56	43	15	26	22	24.8	6	500	16	781
73749	VDN.200 FP	200	58	21	40	33	55	90	60	43	15	26	22	24.8	6	600	18	1002
73759	VDN.225 FP	225	63	23	49	40	66	110	66	44	15	34	27	30.3	8	900	25	1398
73769	VDN.250 FP	249	65	25	49	40	66	110	70	44	15	35	27	30.3	8	1000	28	1551
73780	VDN.300 FP	301	75	25	58	58	94	148	82	56	18	42	38	41.3	10	1100	35	2785
73790	VDN.350 FP	350	92	38	58	58	94	148	90	56	18	42	38	41.3	10	1200	36	4238

VDN.FP+I

Code	Description	D	L	B	d1	d2	d3	d4	d5	l	l2	H	m	R	d'	d''	t	b	C# [Nm]	L# [J]	Δ
73651	VDN.50 FP+I	50	22	12	16	16	-	25	26	19	9	28	M6	19	12	10	11.4	3	55	3	75
73671	VDN.63 FP+I	63	28	13	20	20	-	31	28	24	10	40	M6	24	13	11	12.8	4	75	4	142
73691	VDN.80 FP+I	80	31	14	20	18	28	43	30	28	10	40	M6	32	13	11	12.8	4	120	5	171
73710	VDN.100 FP+I	100	46	21	24	20	35	54	39	33.5	12	50	M6	39	16	13	15.3	5	150	6	307
73720	VDN.125 FP+I	125	57	28	32	26.5	44	70	46	38	15	65	M8	50	20	16	18.3	5	300	8	562
73724	VDN.140 FP+I	140	55	28	32	26.5	44	70	48	38	15	65	M8	58	20	16	18.3	5	300	14	624
73730	VDN.150 FP+I	150	61	30	32	26.5	50	80	48	38	15	65	M8	62	20	16	18.3	5	400	14	687
73740	VDN.175 FP+I	175	66	32	40	33	55	90	56	43	15	80	M10	72.5	26	22	24.8	6	500	16	1017
73750	VDN.200 FP+I	200	68	32	40	33	55	90	60	43	15	90	M10	82	26	22	24.8	6	600	18	1240
73760	VDN.225 FP+I	225	71	33	49	40	66	110	66	44.5	15	90	M10	94	34	27	30.3	8	900	25	1636
73770	VDN.250 FP+I	249	76	36	49	40	66	110	70	44.5	15	90	M10	106	35	27	30.3	8	1000	28	1938
73781	VDN.300 FP+I	301	87	36	58	58	94	148	82	56	18	90	M10	132	42	38	41.3	10	1100	35	3169
73791	VDN.350 FP+I	350	92	38	58	58	94	148	90	56	18	102	M10	157	42	38	41.3	10	1200	36	4388

VDN.FP+IR

Code	Description	D	L	B	d1	d2	d3	d4	d5	l	l2	H	R	d'	d''	t	b	C# [Nm]	L# [J]	Δ
73711	VDN.100 FP+IR	100	51	26	24	20	35	54	39	33.5	12	56	37	16	13	15.3	5	150	6	357
73721	VDN.125 FP+IR	125	57	28	32	26.5	44	70	46	38	15	56	48	20	16	18.3	5	300	8	541
73731	VDN.150 FP+IR	150	61	30	32	26.5	50	80	48	38	15	65	57	20	16	18.3	5	400	14	717
73741	VDN.175 FP+IR	175	66	32	40	33	55	90	56	43	15	80	68	26	22	24.8	6	500	16	1045
73751	VDN.200 FP+IR	200	68	32	40	33	55	90	60	43	15	90	76.5	26	22	24.8	6	600	18	1305
73761	VDN.225 FP+IR	225	71	33	49	40	66	110	66	44.5	15	90	88	34	27	30.3	8	900	25	1698
73771	VDN.250 FP+IR	249	76	36	49	40	66	110	70	44.5	15	90	100	35	27	30.3	8	1000	28	2056
73782	VDN.300 FP+IR	301	87	36	58	58	94	148	82	56	18	90	124	42	38	41.3	10	1100	35	3212

VDN.FP+IRS

Code	Description	D	L	B	d1	d2	d3	d4	d5	l	l2	H	R	d'	d''	t	b	C# [Nm]	L# [J]	Δ
73732	VDN.150 FP+IRS	150	61	30	32	26.5	50	80	48	38	15	65	57	20	16	18.3	5	400	14	733
73742	VDN.175 FP+IRS	175	66	32	40	33	55	90	56	43	15	80	68	26	22	24.8	6	500	16	1053
73752	VDN.200 FP+IRS	200	68	32	40	33	55	90	60	43	15	90	74.5	26	22	24.8	6	600	18	1252
73762	VDN.225 FP+IRS	225	71	33	49	40	66	110	66	44.5	15	90	86	34	27	30.3	8	900	25	1646
73772	VDN.250 FP+IRS	249	76	36	49	40	66	110	70	44.5	15	90	98	35	27	30.3	8	1000	28	2038