



KBMF

IPAD™

EMI FILTER AND LINE TERMINATION FOR PS/2 MOUSE OR KEYBOARD PORTS

MAIN APPLICATIONS

EMI Filter and line termination for mouse and keyboard ports on:

- Desktop computers
- Notebooks
- Workstations
- Servers

FEATURES

- Integrated low pass filters for Data and Clock lines
- Integrated ESD protection
- Integrated pull-up resistors
- Small package size
- Breakdown voltage: $V_{BR} = 6V$ min.

DESCRIPTION

On the implementation of computer systems, the radiated and conducted EMI should be kept within the required levels as stated by the FCC regulations. In addition to the requirements of EMC compatibility, the computing devices are required to tolerate ESD events and remain operational without user intervention.

The KBMF implements a low pass filter to limit EMI levels and provide ESD protection which exceeds IEC 61000-4-2 level 4 standard. The device also implements the pull up resistors needed to bias the data and clock lines. The package is the SOT23-6L which is ideal for situations where board space is at a premium.

BENEFITS

- EMI / RFI noise suppression
- ESD protection exceeding IEC61000-4-2 level 4
- High flexibility in the design of high density boards

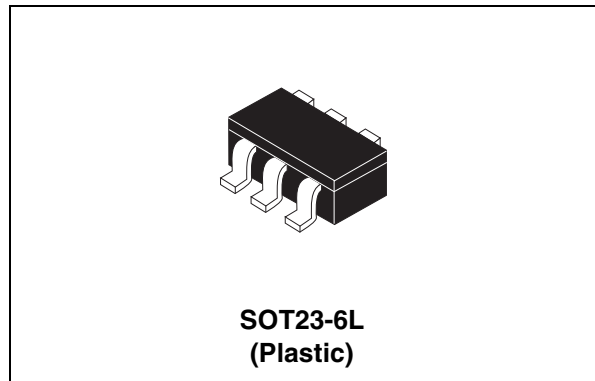
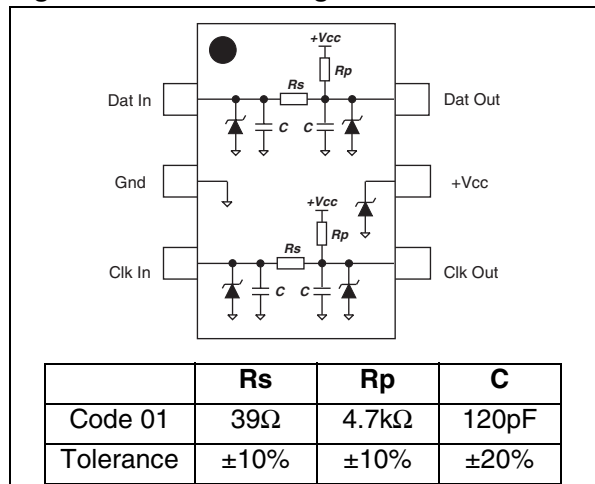

Table 1: Order Code

Part Number	Marking
KBMF01SC6	KM1

Figure 1: Functional Diagram



COMPLIES WITH THE FOLLOWING ESD STANDARDS:

IEC 61000-4-2 (R = 330Ω C = 150pF)

- Level 4 ±15 kV (air discharge)
- ±8 kV (contact discharge)

MIL STD 883C, Method 3015-6

- Class 3 C = 100pF R = 1500Ω
- 3 positive strikes and
- 3 negative strikes (F = 1 Hz)

TM: IPAD is a trademark of STMicroelectronics.

Table 2: Absolute Maximum Ratings ($T_{amb} = 25^{\circ}\text{C}$)

Symbol	Parameter	Value	Unit
V_{PP}	ESD discharge R = 330W C = 150pF contact discharge ESD discharge - MIL STD 883 - Method 3015-6	± 12 ± 25	kV
T_j	Junction temperature	150	$^{\circ}\text{C}$
T_{stg}	Storage temperature range	- 55 to +150	$^{\circ}\text{C}$
T_L	Lead solder temperature (10 second duration)	260	$^{\circ}\text{C}$
T_{op}	Operating temperature Range	0 to 70	$^{\circ}\text{C}$
P_r	Power rating per resistor	100	mW

Table 3: Electrical Characteristics ($T_{amb} = 25^{\circ}\text{C}$)

Symbol	Parameters	Test conditions	Min	Typ	Max	Unit
I_R	Diode leakage current	$V_{RM} = 5.0\text{V}$			10	μA
V_{BR}	Diode breakdown voltage	$I_R = 1\text{mA}$	6			V
V_F	Diode forward voltage drop	$I_F = 50\text{mA}$		0.9		V

TECHNICAL INFORMATION

1. EMI FILTERING

The KBMFxxSC6 ensure a filtering protection against ElectroMagnetic and RadioFrequency Interferences thanks to its low-pass filter structure. This filter is characterized by the following parameters :

- cut-off frequency
- Insertion loss
- high frequency rejection

Figure 2: Measurements configuration

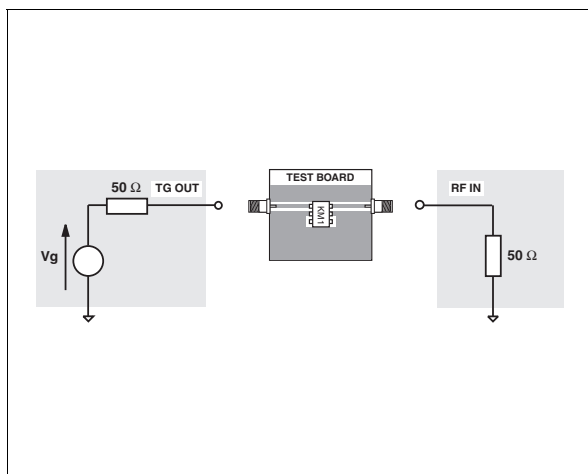
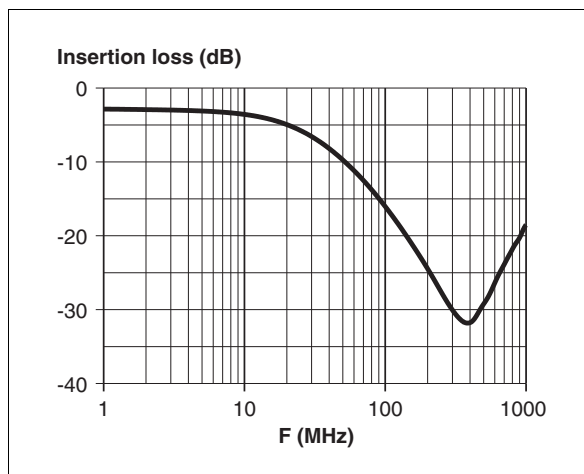

Figure 3: KBMF attenuation curve



2. ESD PROTECTION

The KBMFxxSC6 is particularly optimized to perform ESD protection. ESD protection is based on the use of device which clamps at:

$$V_{\text{output}} = V_{\text{BR}} + R_{\text{d}} \cdot I_{\text{PP}}$$

This protection function is splitted in 2 stages. As shown in figure 4, the ESD strikes are clamped by the first stage S1 and then its remaining overvoltage is applied to the second stage through the resistor R. Such a configuration makes the output voltage very low at the V_{output} level.

Figure 4: ESD clamping behavior

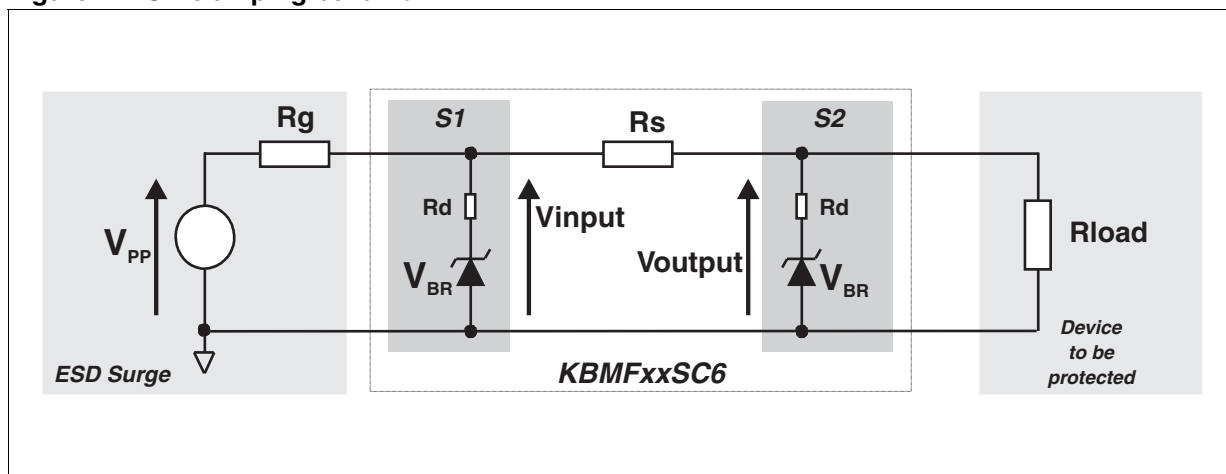

To have a good approximation of the remaining voltages at both V_{input} and V_{output} stages, we give the typical dynamical resistance value R_{d} . By taking into account these following hypothesis : $R_{\text{t}} > R_{\text{d}}$, $R_{\text{g}} > R_{\text{d}}$ and $R_{\text{load}} > R_{\text{d}}$, it gives these formulas:

$$V_{\text{input}} = \frac{R_{\text{g}} \cdot V_{\text{BR}} + R_{\text{d}} \cdot V_{\text{g}}}{R_{\text{g}}}$$

$$V_{\text{output}} = \frac{R_{\text{s}} \cdot V_{\text{BR}} + R_{\text{d}} \cdot V_{\text{input}}}{R_{\text{t}}}$$

The results of the calculation done for $V_{\text{PP}}=8\text{kV}$, $R_{\text{g}}=330\Omega$ (IEC 61000-4-2 standard), $V_{\text{BR}}=7\text{V}$ (typ.) and $R_{\text{d}} = 1\Omega$ (typ.) give:

$$V_{\text{input}} = 31.2 \text{ V}$$

$$V_{\text{output}} = 7.8 \text{ V}$$

This confirms the very low remaining voltage across the device to be protected. It is also important to note that in this approximation the parasitic inductance effect was not taken into account. This could be few tenths of volts during few ns at the input side. This parasitic effect is not present at the output side due the low current involved after the resistance R_{s} .

The measurements done here after show very clearly (figure 6) the high efficiency of the ESD protection :

- no influence of the parasitic inductances on output stage
- V_{output} clamping voltage very close to V_{BR} (positive strike) and $-V_{\text{F}}$ (negative strike)

Figure 5: Measurement conditions

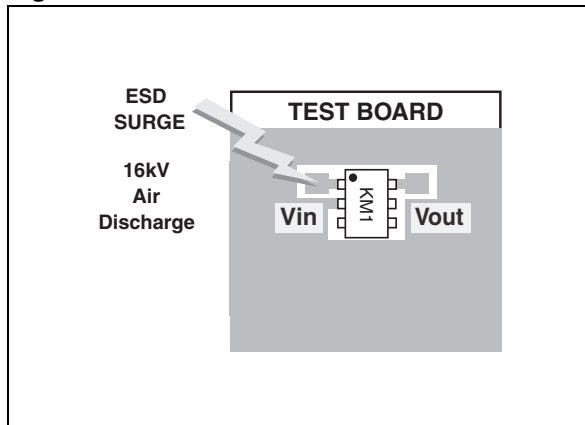
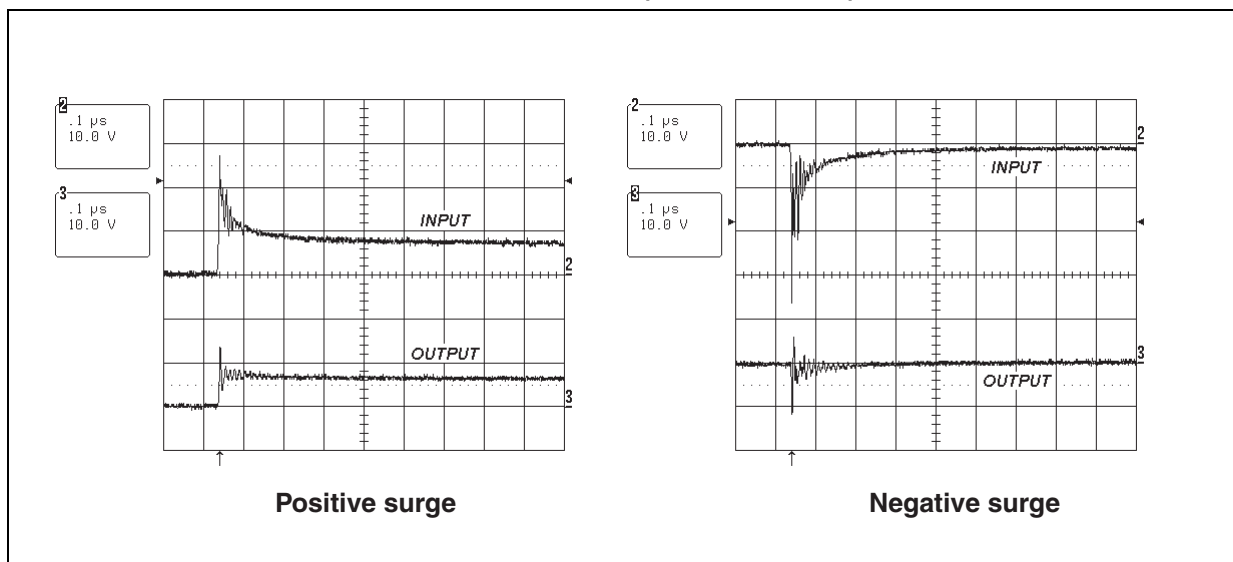

Figure 6: Remaining voltage at both stages S1 (V_{input}) and S2 (V_{output}) during ESD surge



Please note that the KBMF01SC6 is not only acting for positive ESD surges but also for negative ones. For these kind of disturbances it clamps close to ground voltage as shown in the Negative Surge figure.

3. LATCH-UP PHENOMENA

The early ageing and destruction of IC's is often due to latch-up phenomena which is mainly induced by dV/dt . Thanks to its structure, the KBMF01SC6 provides a high immunity to latch-up phenomena by smoothing very fast edges.

4. CROSSTALK BEHAVIOR

Figure 7: Crosstalk phenomena

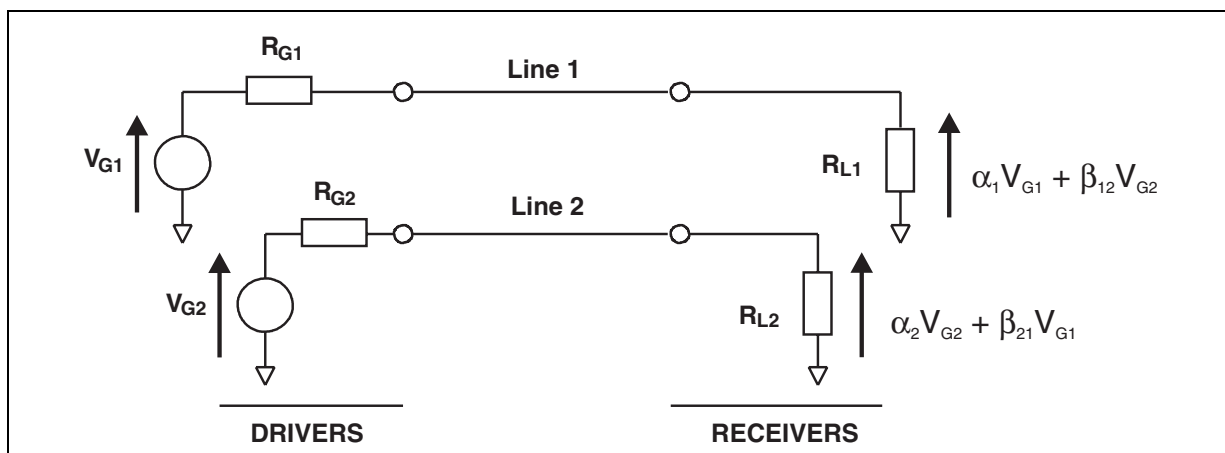

The crosstalk phenomena is due to the coupling between 2 lines. The coupling factor (β_{12} or β_{21}) increases when the gap across lines decreases, this is the reason why we provide crosstalk measurements for monolithic device to guarantee negligible crosstalk between the lines. In the example above the expected signal on load R_{L2} is $\alpha_2 V_{G2}$, in fact the real voltage at this point has got an extra value $\beta_{21} V_{G1}$. This part of the V_{G1} signal represents the effect of the crosstalk phenomenon of the line 1 on the line 2. This phenomenon has to be taken into account when the drivers impose fast digital data or high frequency analog signals in the disturbing line. The perturbed line will be more affected if it works with low voltage signal or high load impedance (few $k\Omega$).

Figure 8: Analog Crosstalk measurements configuration

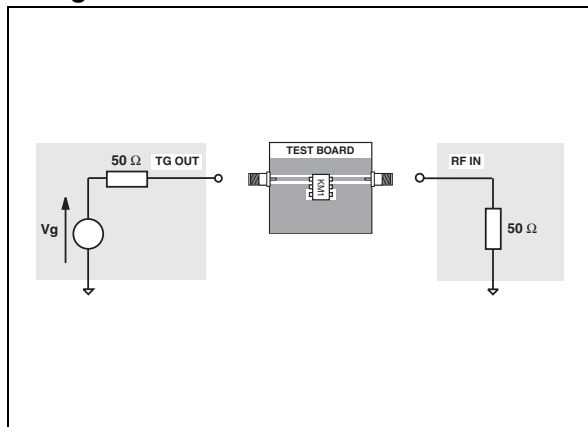

Figure 9: Typical Analog Crosstalk measurement

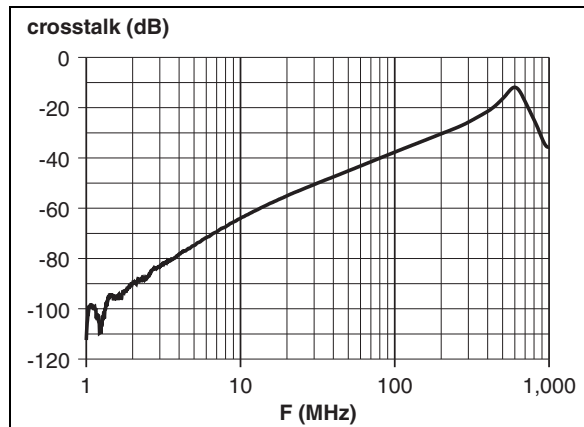

Figure 8 gives the measurement circuit for the analog crosstalk application. In figure 9, the curve shows the effect of the Data line on the CLK line. In usual frequency range of analog signals (up to 100MHz) the effect on disturbed line is less than -37dB.

Figure 10: Digital crosstalk measurements configuration

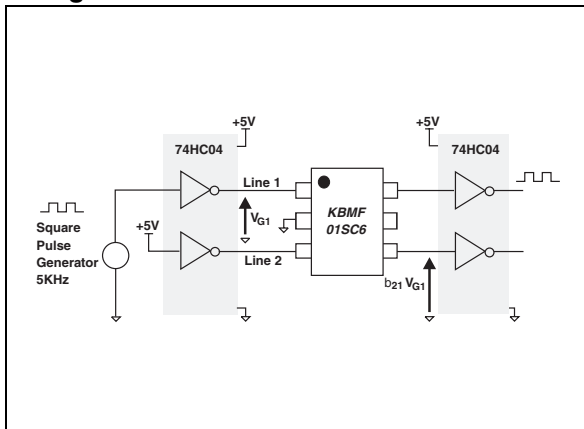

Figure 11: Digital crosstalk measurements

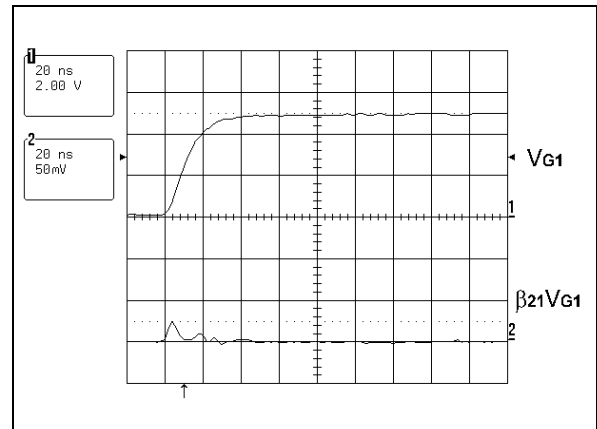
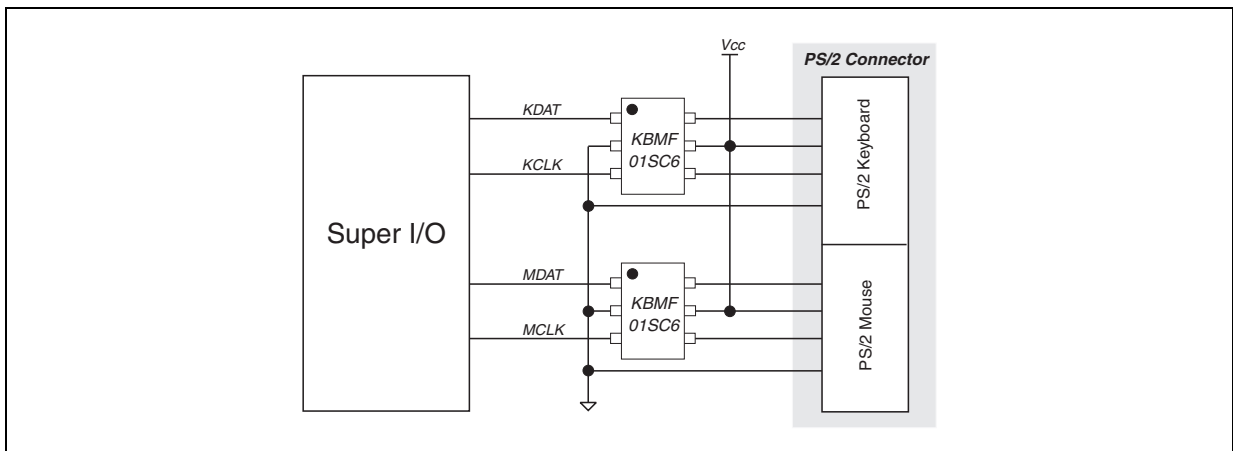

Figure 10 shows the measurement circuit used to quantify the crosstalk effect in a classical digital application.

Figure 11 shows that in such a condition signal from 0 to 5V and rise time of few ns, the impact on the other line is less than 50mV peak to peak (below the logic high threshold voltage). The measurements performed with falling edges gives the results within the same range.

5. APPLICATION EXAMPLE

Figure 12: Implementation of KBMFxxSC6 in a typical application



The KBMF01SC6 device could be used on PS/2 mouse or keyboard as indicated by figure 12.

Figure 13: SOT23-6L Package Mechanical Data

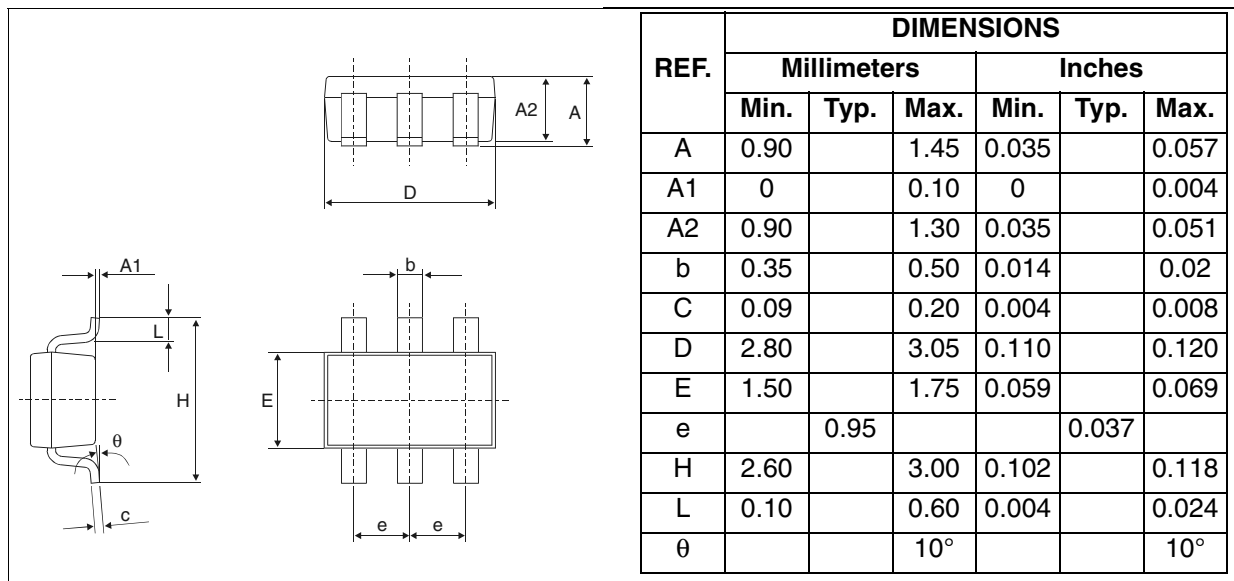

Figure 14: SOT23-6L Foot print dimensions (in millimeters)

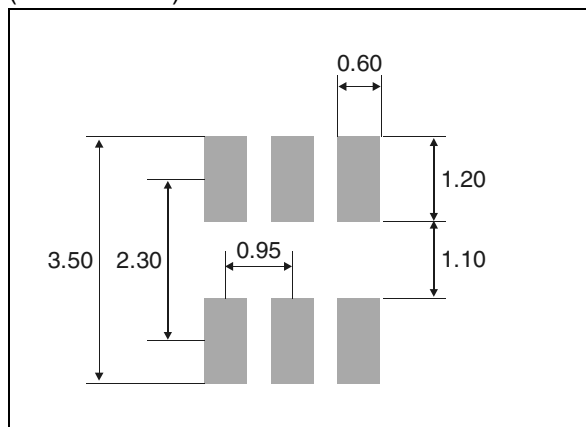

Table 4: Mechanical Specifications

Lead plating	Tin-lead
Lead plating thickness	5µm min. 25µm max.
Lead material	Sn / Pb (70% to 90%Sn)
Lead coplanarity	10µm max
Body material	Molded epoxy
Flammability	UL94V-0

Table 5: Ordering Information

Ordering code	Marking	Package	Weight	Base qty	Delivery mode
KBMF01SC6	KM1	SOT23-6L	16.7 mg	3000	Tape & reel

Table 6: Revision History

Date	Revision	Description of Changes
Feb-2003	1D	Last update.
28-Oct-2004	2	SOT23-6L package dimensions change for reference "D" from 3.0 millimeters (0.118 inches) to 3.05 millimeters (0.120 inches).

Information furnished is believed to be accurate and reliable. However, STMicroelectronics assumes no responsibility for the consequences of use of such information nor for any infringement of patents or other rights of third parties which may result from its use. No license is granted by implication or otherwise under any patent or patent rights of STMicroelectronics. Specifications mentioned in this publication are subject to change without notice. This publication supersedes and replaces all information previously supplied. STMicroelectronics products are not authorized for use as critical components in life support devices or systems without express written approval of STMicroelectronics.

The ST logo is a registered trademark of STMicroelectronics.
All other names are the property of their respective owners

© 2004 STMicroelectronics - All rights reserved

STMicroelectronics group of companies

Australia - Belgium - Brazil - Canada - China - Czech Republic - Finland - France - Germany - Hong Kong - India - Israel - Italy - Japan -
Malaysia - Malta - Morocco - Singapore - Spain - Sweden - Switzerland - United Kingdom - United States of America
www.st.com