

# FLUKE®

# 712

## *RTD Calibrator*

### *Instruction Sheet*

#### ***Introduction***

Fluke Model 712 RTD Calibrator is a handheld tool for calibrating RTD (Resistance Temperature Detector) transmitters, including most pulsed transmitters. It simulates and measures seven different types of RTDs, in units of °C or °F. It also simulates and measures resistance in units of ohms. It does not source and measure simultaneously.

Your calibrator is supplied with a Flex-Stand™ holster, an installed 9 V alkaline battery, two sets of test leads, and this instruction sheet.

If the calibrator is damaged or something is missing, contact the place of purchase immediately. Contact your Fluke distributor for information about accessories. To order replacement parts or spares, see "Replacement Parts."

The next table lists the RTD types supported by the calibrator, with their ranges, resolution, and the allowable excitation current from an RTD measurement device under test. All RTD types use IPTS-68 curves. Full calibrator specifications are listed at the end of this instruction sheet.

*Note*

*Since ohms input and output units are available, you can use the calibrator for any unsupported RTD type by selecting the ohms range and making manual calculations or referring to tables.*

**Supported RTD Types**

RTD Type	Temperature Range and Resolution		Allowable Excitation (Note 1)
	°C	°F	mA
Ni 120	-80.0 to 260.0	-112.0 to 500.0	0.15 to 2.00
Pt 100 385	-200.0 to 800.0	-328.0 to 1472.0	0.15 to 2.00
Pt 200 385	-200.0 to 630.0	-328.0 to 1166.0	0.15 to 2.00
Pt 500 385	-200.0 to 630.0	-328.0 to 1166.0	0.05 to 0.80
Pt 1000 385	-200.0 to 630.0	-328.0 to 1166.0	0.05 to 0.40
Pt 100 392	-200.0 to 630.0	-328.0 to 1166.0	0.15 to 2.00
Pt 100 JIS	-200.0 to 630.0	-328.0 to 1166.0	0.15 to 2.00
	<b>Range and Resolution for Ohms Simulate and Measure</b>		
R (Note 2)	15.0 Ω to 400.0 Ω		0.15 to 2.00
R	400.0 Ω to 1500.0 Ω		0.05 to 0.80
R	1500.0 Ω to 3200.0 Ω		0.05 to 0.40

*Note 1: This column is for simulate mode only. It shows the allowable excitation current from an ohmmeter or RTD measurement device connected to the calibrator.*

*Note 2: The R annunciator signifies "resistance," not an RTD type. You select it the same way as an RTD type.*

## Safety Information







### Warning

To avoid possible electric shock or personal injury:

- **Never apply more than 30 V between any two terminals, or between any terminal and earth ground.**
- **Make sure the battery door is closed and latched before you operate the calibrator.**
- **Remove test leads from the calibrator before you open the battery door.**
- **Do not operate the calibrator if it is damaged.**
- **Do not operate the calibrator around explosive gas, vapor, or dust.**

When servicing the calibrator, use only specified replacement parts.

#### International Symbols

Symbol	Meaning
	Earth ground
	Fuse
	Battery
	Refer to this instruction sheet for information about this feature.
	Double insulated
	Conforms to relevant Canadian Standards Association directives
	Conforms to European Union directives

# Getting Acquainted with the Calibrator

Press the green  pushbutton to turn the calibrator on and off. Press the INPUT/OUTPUT pushbutton to select either INPUT (measuring) or OUTPUT (simulating).

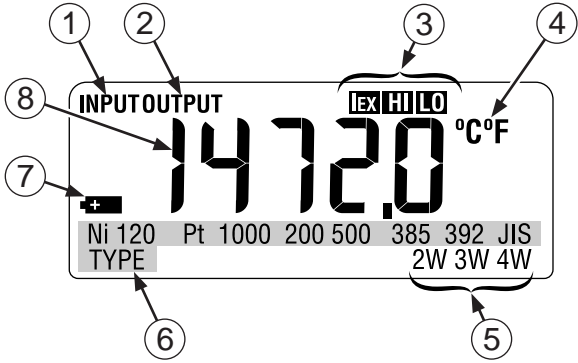

kg03f.eps











## Display Elements

Element	Meaning
① INPUT	Lit when measuring an RTD or resistance
② OUTPUT	Lit when simulating an RTD or resistance
③ <b>EX HI LO</b>	<p><b>EX LO</b> When simulating an RTD or ohms, the excitation current from the measuring device under test is too low. The calibrator output is unspecified.</p> <p><b>EX HI</b> When simulating an RTD or ohms, the excitation current from the measuring device under test is too high. The calibrator output is unspecified.</p>
④ °C, °F	When an RTD type is selected, one of these is lit to show the selected temperature scale.

### Display Elements (cont.)

Element	Meaning
⑤ 2W, 3W, 4W	When measuring an RTD, one of these is lit to indicate a two-wire, three-wire, or four-wire configuration. These annunciators are not used when simulating an RTD or resistance (output).
⑥ TYPE	This and one of the RTD type annunciators (example, Ni 120) shows the selected RTD type.
⑦ 	Lit when the battery is low.
⑧ Numerals	Show the measured or simulated value in degrees or ohms. When OL appears, the value is out of range.

### Pushbutton Functions

Pushbutton	Function
	Press to select a different RTD type. When you select the R type (ohms), displayed units are ohms, not degrees.
	Press to toggle temperature scales between Celsius and Fahrenheit.
	Press to select input (measure) or output (simulate) mode.
2W 3W 4W  	In simulate mode, press  to step up or down 50° or 50 Ω. In measurement mode, press  or  to select a two-wire, three-wire, or four-wire RTD input configuration. You will see the corresponding 2W, 3W, or 4W on the display.
 	Press to scroll up or down 0.1° or 0.1 Ω. Hold down to scroll faster.

# Simulating an RTD

To simulate an RTD, proceed as follows:

1. Press  $\text{\textcircled{O}}$  to turn on the power.
2. If the calibrator is in input mode (INPUT on the display), press INPUT OUTPUT once. Make sure the display shows OUTPUT.
3. Press  $\text{\textcircled{RTD TYPE}}$  to select the desired RTD type.
4. Connect test leads to the terminals of the RTD measuring device as shown. Use only the two center outputs (labeled 2W 3W 4W OUTPUT).

## Notes

*If you connect the calibrator to an ohmmeter or RTD measuring device with auto ranging, you must lock its range. Select a range that produces an excitation current in allowed range shown in the first table, Supported RTD Types.*

*To simulate an RTD for a pulsed transmitter, wait for the calibrator output to stabilize. This can take up to 10 seconds.*

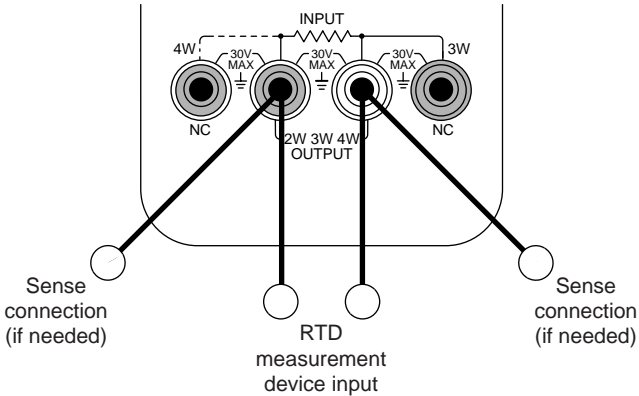

# Measuring an RTD

To measure an RTD, proceed as follows:

1. Press **Ⓞ** to turn on the power.
2. If the calibrator is in simulate mode (OUTPUT on the display), press INPUT OUTPUT once. Make sure the display shows INPUT.
3. Press **RTD TYPE** to select the desired RTD type.
4. Press **▲** or **▼** to select a two-wire, three-wire, or four-wire RTD input configuration. Look for the 2W, 3W, or 4W annunciator on the display to verify that the configuration is set correctly.
5. Connect test leads to the RTD as shown below. Use two, three, or four inputs, depending on the setting of 2W, 3W, or 4W on the display.

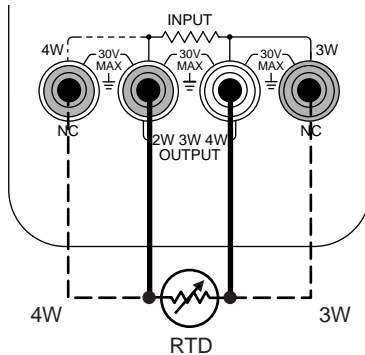

## ***Maintenance***

For maintenance procedures not described in this sheet, contact a Fluke Service Center.

### ***In Case of Difficulty***

- Check the battery and test leads. Replace as necessary.
- Review this sheet to make sure you are using the calibrator correctly.

If the calibrator needs repair, contact a Fluke Service Center. If the calibrator is under warranty, see the warranty statement for terms. If the warranty has lapsed, the calibrator will be repaired and returned for a fixed fee. Contact a Fluke Service Center for information and price.

### ***Cleaning***

Periodically wipe the case with a damp cloth and detergent; do not use abrasives or solvents.

### ***Calibration***

Calibrate your calibrator once a year to ensure that it performs according to its specifications. A calibration manual is available (PN 686540). Call 1-800-526-4731 from the USA and Canada. In other countries, contact a Fluke Service Center.

## Replacing the Battery

When the  symbol appears on the display, replace the battery with a 9 V alkaline battery.

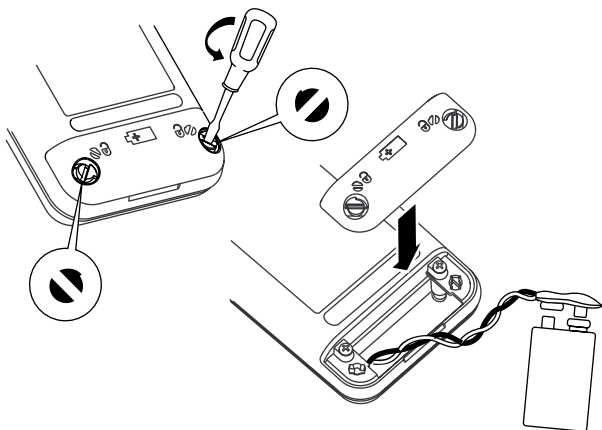

it07f.eps

## ***Replacing the Fuse***

### **⚠ Warning**

**To avoid personal injury or damage to the calibrator, use only a 0.125A 250V fast fuse, Littelfuse® 2AG.**

To determine if fuse F1 is blown, put the calibrator in simulate mode (OUTPUT on the display) and check for proper resistance at the calibrator's OUTPUT terminals. An open or very high impedance suggests fuse F1 is blown.

Replace the fuse as follows:

1. Remove the test leads and turn the calibrator off.
2. Remove the battery door.
3. Remove the three Phillips-head screws from the case bottom and turn the case over.
4. Gently lift the top cover from the end nearest the input/output terminals until it unsnaps from the bottom cover.
5. Replace the fuse with a 0.125 A 250 V fast fuse, Littelfuse® 2AG.
6. Fit the top and bottom covers together, engaging the two snaps. Make sure that the gasket is properly seated. Reinstall the three screws.
7. Replace the battery door.

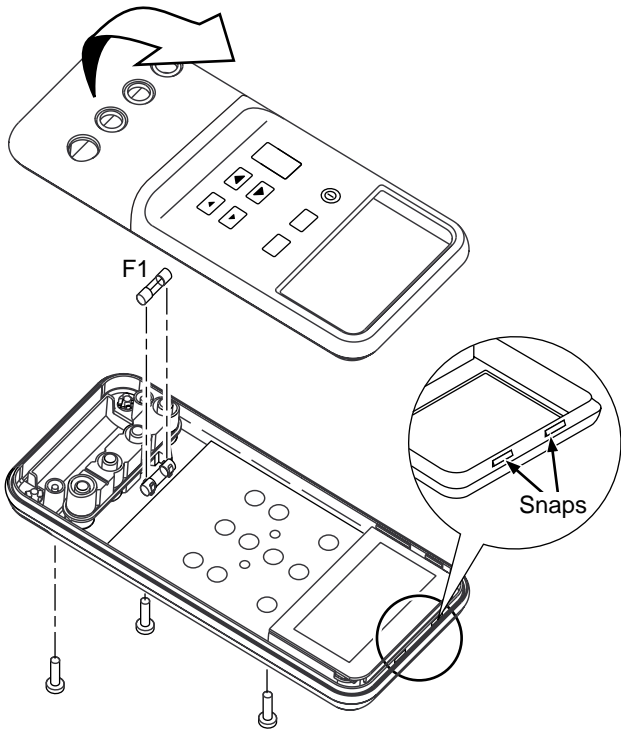

# ***Replacement Parts and Accessories***

## **Replacement Parts**

<b>Item</b>	<b>Description</b>	<b>PN or Model no.</b>	<b>Qty.</b>
BT1	9V battery, ANSI/NEDA 1604A or IEC 6LR61	614487	1
CG81Y	Holster, Yellow	CG81Y	1
⚠ F1	Fuse, 125 mA, 250V fast	686527	1
MP85	Case top	620192	1
MP86	Case bottom	620168	1
H2, 3, 4	Case screw	832246	3
MP89, 90	Non-skid foot	824466	2
MP8	O-ring for input/output receptacle	831933	1
MP92	Battery door	619947	1
H5, 6	Battery door fasteners	948609	2
S1	Keypad	687084	1
-	712 Instruction Sheet	650280	1
-	Test lead, red	688051	2
-	Test lead, black	688066	2
-	71X Series Calibration Manual	686540	Option

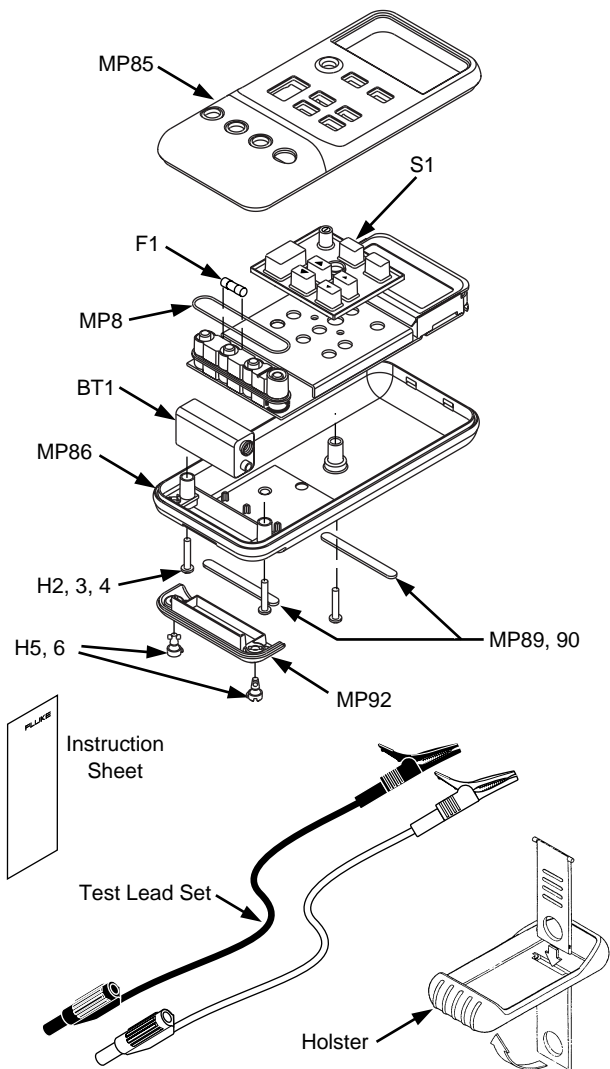

## Specifications

Specifications are based on a one year calibration cycle and apply for ambient temperature from +18°C to +28°C unless stated otherwise.

### RTD and Ohms Simulation

Ohms Range	Excitation Current from Measurement Device	Accuracy, $\pm \Omega$
15 $\Omega$ to 400 $\Omega$	0.15 mA to 0.5 mA	0.15
15 $\Omega$ to 400 $\Omega$	0.5 mA to 2 mA	0.1
400 $\Omega$ to 1.5 k $\Omega$	0.05 mA to 0.8 mA	0.5
1.5 k $\Omega$ to 3.2 k $\Omega$	0.05 mA to 0.4 mA	1

*Maximum input voltage: 30 V*

### RTD and Ohms Measurement

Ohms Range	Accuracy, Four-Wire $\pm \Omega$
15 $\Omega$ to 400 $\Omega$	0.1
400 $\Omega$ to 1.5 k $\Omega$	0.5
1.5 k $\Omega$ to 3.2 k $\Omega$	1

*Maximum input voltage: 30 V*  
*Excitation current from 712: 0.3 mA*

## ***General Specifications***

**Resolution:** RTD: 0.1°C, 0.1°F. Ohms: 0.1Ω

**Maximum voltage applied between any terminal and earth ground or between any two terminals:** 30 V

**Storage temperature:** -40°C to 60°C

**Operating temperature:** -10°C to 55°C

**Operating altitude:** 3000 meters maximum

**Temperature coefficient:** 0.005% of ohms range per °C for temperature ranges -10°C to 18°C and 28°C to 55°C. Ohms ranges are 400 Ω, 1.5 kΩ, and 3.2 kΩ.

**Relative humidity:** 95% up to 30°C, 75% up to 40°C, 45% up to 50°C, and 35% up to 55°C

**Vibration:** Random 2 g, 5 Hz to 500 Hz

**Shock:** 1 meter drop test

**Safety:** Certified as compliant to CAN/CSA C22.2 No. 1010.1:1992. Complies with ANSI/ISA S82.01-1994.

**Power requirements:** Single 9 V battery (ANSI/NEDA 1604A or IEC 6LR61)

**Size:** 32 mm H x 87 mm W x 187 mm L (1.25 in H x 3.41 in W x 7.35 in L);

With holster and Flex-Stand: 52 mm H x 98 mm W x 201 mm L (2.06 in H x 3.86 in W x 7.93 in L)

**Weight:** 337 g (11.9 oz);

With holster and Flex-Stand: 587 g (20.7 oz)

## ***How to Contact Fluke***

To order accessories, receive operating assistance, or get the location of the nearest Fluke distributor or Service Center, call:

1-800-44FLUKE (1-800-443-5853) in U.S.A. and Canada

+31-402-678-200 in Europe

+1-425-356-5500 from other countries

Address correspondence to:

Fluke Corporation  
P.O. Box 9090,  
Everett, WA 98206-9090  
U.S.A.

Fluke Europe B.V.  
P.O. Box 1186,  
5602 BD Eindhoven  
The Netherlands

Visit us on the World Wide Web at: **[www.fluke.com](http://www.fluke.com)**

### **LIMITED WARRANTY & LIMITATION OF LIABILITY**

This Fluke product will be free from defects in material and workmanship for three years from the date of purchase. This warranty does not cover fuses, disposable batteries or damage from accident, neglect, misuse or abnormal conditions of operation or handling. Resellers are not authorized to extend any other warranty on Fluke's behalf. To obtain service during the warranty period, send your defective calibrator to the nearest Fluke Authorized Service Center with a description of the problem.

THIS WARRANTY IS YOUR ONLY REMEDY. NO OTHER WARRANTIES, SUCH AS FITNESS FOR A PARTICULAR PURPOSE, ARE EXPRESSED OR IMPLIED. FLUKE IS NOT LIABLE FOR ANY SPECIAL, INDIRECT, INCIDENTAL OR CONSEQUENTIAL DAMAGES OR LOSSES, ARISING FROM ANY CAUSE OR THEORY. Since some states or countries do not allow the exclusion or limitation of an implied warranty or of incidental or consequential damages, this limitation of liability may not apply to you.