

SPECIFICATIONS	
CONTACT CARRIER MATERIAL	NYLON OR TPU
MOLDED HEAD MATERIAL/COLOR	TPU/YELLOW
CONTACT MATERIAL/PLATING	BRASS/GOLD
COUPLING NUT MATERIAL/PLATING	BRASS/NICKEL
RATED CURRENT [A]	4.0 A
RATED VOLTAGE [V]	250 V
OUTER CABLE JACKET MATERIAL/COLOR	TPE/YELLOW
CONDUCTOR INSULATION MATERIAL	PVC
NUMBER OF CONDUCTORS [AWG]	5x18 AWG
TEMPERATURE RANGE	-40°C to +105°C (-40°F to +221°F)
PROTECTION CLASS	MEETS NEMA 1,3,4,6P AND IEC IP68

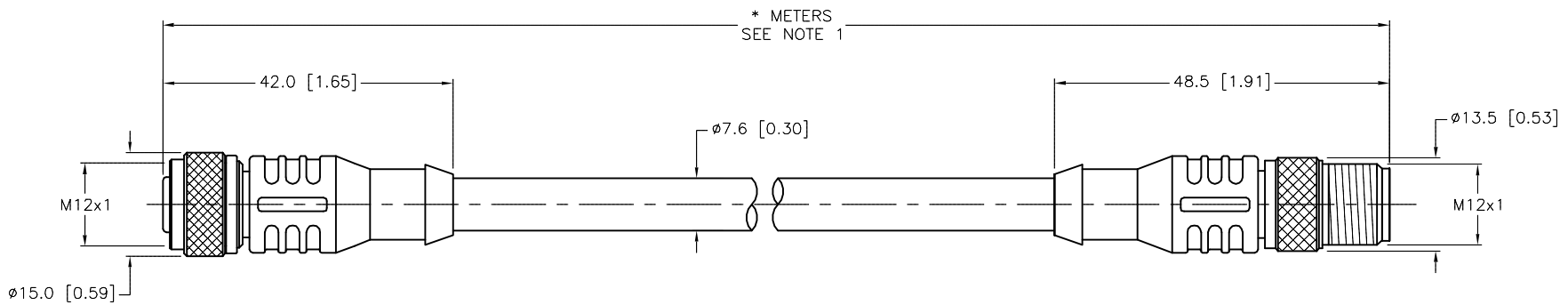

CABLE LENGTH	TOLERANCE *
ALL LENGTHS	+ 4% (OR 50mm) OF LENGTH - 0% (OR 0mm) OF LENGTH WHICHEVER IS GREATER
STRIP LENGTH	TOLERANCE *
0-7mm	±0.5mm
8-29mm	±1.0mm
30-49mm	±2.0mm
50-69mm	±3.0mm
70-100mm	±4.0mm
OVER 100mm	±5.0mm

*** UNLESS OTHERWISE SPECIFIED**

- NOTES:
- "*" INDICATES CABLE LENGTH IN METERS. CONTACT TURCK TO ORDER SPECIFIC LENGTHS.
 - "/S1587" DESIGNATES "WELDLIFE" CABLE.
 - "/SV" DESIGNATES SPECIAL PACKAGING FOR VENDING MACHINES.

SOURCE DRAWING - FOR REFERENCE ONLY

RELATED DOCUMENTS 1. 2. 3. 4.	3RD ANGLE PROJECTION 	THIS DRAWING IS CONFIDENTIAL AND THE PROPERTY OF TURCK INC. USE OF THIS DOCUMENT WITHOUT WRITTEN PERMISSION IS PROHIBITED.		TURCK INC High Technology Sensors and Automation Controls 3000 CAMPUS DRIVE MINNEAPOLIS, MN 55441 1-800-544-7769 (763) 553-7300 (763) 553-0708 fax turck.com	
	MATERIAL SEE SPECIFICATIONS	DRFT RWC	DATE 07/31/07	DESCRIPTION RKC 4.5T-*--RSC 4.5T/S1587/SV	
FINISH SEE SPECIFICATIONS	ALL DIMENSIONS DISPLAYED ON THIS DRAWING ARE FOR REFERENCE ONLY	APVD	SCALE 1=1.0	IDENTIFICATION NO.	
		UNIT OF MEASUREMENT MILLIMETER [INCH]		REV D	
		DO NOT SCALE THIS DRAWING		FILE: 777018677	
				SHEET 1 OF 1	

D	UPDATE CABLE DIAMETER	KMY	12/06/12	40297
REV	DESCRIPTION	BY	DATE	ECO NO.