

- ⌘ Re-timing
- ⌘ Data rate up to 250 kbit/s
- ⌘ 9-position D-sub connector
- ⌘ Redundant power supply inputs
- ⌘ Status interface for fault indication
- ⌘ Fibre link fault indication (Red)
- ⌘ Design for harsh environments
- ⌘ -40 to +70°C operating temperature

ODW-621

RS-232

Point-to-point applications

The ODW-621 is designed for point-to-point applications between devices with an RS-232 interface. The ODW-621 is designed for harsh industrial usage as well as road or railway installations meeting industrial level EMC specifications and having a wide operating temperature range.

The maximum distance of the fibre link depends on selected transceiver and fibre type. Fibre distances up to 80 km (50 miles) are possible using singlemode fibre.

The unit also has a re-timing function that eliminates the problem of jitter and hence ensures reliable communications in all situations.

It is possible to use the ODW-621 in conjunction with the ODW-631 to provide protocol conversion from RS-232 to RS-422/485 at either end of the optical link.

The ODW-621 can also be used in start/end points in a multidrop application together with ODW-632 / 622.

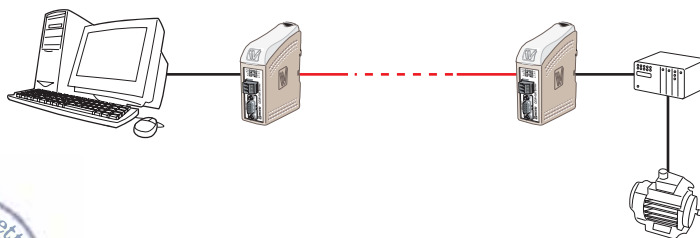

ODW-Series

Technical data

Power	
Rated voltage	12 to 48 VDC 24 VAC
Operating voltage	10 to 60 VDC 20 to 30 VAC*
Rated current	ODW-611/621/631 300 mA @ 12 VDC 150 mA @ 24 VDC 75 mA @ 48 VDC
	ODW-612/622/632 400 mA @ 12 VDC 200 mA @ 24 VDC 100 mA @ 48 VDC
Rated frequency	DC: 0 Hz AC: 48 to 62 Hz
Inrush current I ² t	0.2 A ² s
Startup current**	1.0 A _{peak}
Polarity	Polarity independent
Redundant power input	Yes
Isolation to	Serial port and Status port
Connection	Detachable screw terminal
Connector size	0.2 – 2.5 mm ² (AWG 24-12)
Shielded cable	Not required

* Not available on ODW-611/612 ** External supply current capability for proper startup

Status	
Port type	Signal relay, changeover contacts
Rated voltage	Up to 48 VDC
Operating voltage	Up to 60 VDC
Contact rating	500 mA @ 48 VDC
Contact resistance	< 50 mΩ
Isolation to	Serial port and Power port
Connection	Detachable screw terminal
Connector size	0.2 – 2.5 mm ² (AWG 24 – 12)
Shielded cable	Not required

LC-connectors SFP (Small Form-Factor Pluggable)			
LC-2 Multimode	up to 5 km (3.1)	LC-40 Singlemode	up to 40 km (25 mi)
LC-15 Singlemode	up to 15 km (9.3 mi)	LC-80 Singlemode	up to 80 km (50 mi)

RS-232	
Electrical specification	EIA RS-232
Data rate	300 bit/s – 250 kbit/s
Data format	9 – 12 bits (Protocol dependent mode) Arbitrary (Transparent mode)
Protocol	Start-bit followed by 8 – 11 bits (Protocol dependent mode) Arbitrary (Transparent mode)
Re-timing	Yes (Protocol dependent mode)
Deviation, Input data rate	Byte: 4%; Bit 49% (Protocol dependent mode)
Transmission range	15 m
Isolation to	Status and Power port
Connection	9-pin D-sub female (DCE)
Shielded cable	Not required, except when installed in railway applications as signalling and telecommunications apparatus and located close to rails*
Conductive housing	Isolated to all other circuits and housings

* To minimise the risk of interference, a shielded cable is recommended when the cable is located inside 3 m boundary to the rails and connected to this port. The cable shield should be properly connected (360°) to an earthing point within 1 m from this port. This earthing point should have a low impedance connection to the conductive enclosure of the apparatus cabinet, or similar, where the unit is built-in. This conductive enclosure should be connected to the earthing system of an installation and may be directly connected to the protective earth.

RS-422/485	
Electrical specification	EIA RS-485, 2-wire (PROFIBUS DP) or EIA RS-422, 4-wire twisted pair
Data rate	300 bit/s – 1.5 Mbit/s, RS-422/485 9 600 kbit/s – 12 Mbit/s, PROFIBUS DP
Data format	9 – 12 bits (Protocol dependent mode) Arbitrary (Transparent mode)
Protocol	Start-bit followed by 8 – 11 bits (Protocol dependent mode) Arbitrary (Transparent mode), RS-422/485 PROFIBUS DP (RS-485)
Re-timing	Yes (Protocol dependent mode, RS-422/485)
Deviation, Input data rate	Byte: 4%; Bit 49% (Protocol dependent mode)
Turning time (2-wire RS-485)	One t_{bit} $t_{bit} = 1 / \text{Baud rate}$ (Baud rate in bit/s) In accordance with EN 50 170, PROFIBUS DP
Transmission range	< 1200 m, depending on data rate and cable type (EIA RS-485)
Settings	120 Ω termination and failsafe biasing 680 Ω , RS-422/485 None, external termination and failsafe biasing, PROFIBUS DP
Protection	Installation Fault Tolerant (up to ± 60 V)
Isolation to	Status and Power port
Connection	Detachable screw terminal, RS-422/485 9-pin D-sub female, PROFIBUS DP
Connector size	0.2 – 2.5 mm ² (AWG 24 – 12)
Shielded cable	Not required

Type tests and environmental conditions for the ODW-series

Electromagnetic Compatibility			
Phenomena	Test	Description	Level
ESD	EN 61000-4-2	Enclosure contact	± 6 kV
		Enclosure air	± 8 kV
RF field AM modulated	IEC 61000-4-3	Enclosure	20 V/m 80% AM (1 kHz), 80 – 2000 MHz
RF field 900 MHz	ENV 50204	Enclosure	20 V/m pulse modulated 200 Hz, 900 ± 5 MHz
Fast transient	EN 61000-4-4	Signal ports	± 2 kV
		Power ports	± 2 kV
Surge	EN 61000-4-5	Signal ports unbalanced	± 2 kV line to earth, ± 2 kV line to line
		Signal ports balanced	± 2 kV line to earth, ± 1 kV line to line
		Power ports	± 2 kV line to earth, ± 2 kV line to line
RF conducted	EN 61000-4-6	Signal ports	10 V 80% AM (1 kHz), 0.15 – 80 MHz
		Power ports	10 V 80% AM (1 kHz), 0.15 – 80 MHz
Power frequency magnetic field	EN 61000-4-8	Enclosure	100 A/m, 50 Hz, 16.7 Hz & 0 Hz
Pulse Magnetic field	EN 61000-4-9	Enclosure	300 A/m, 6.4 / 16 µs pulse
Voltage dips and interruption	EN 61000-4-11	AC power ports	10 & 5 000 ms, interruption 10 & 500 ms, 30% reduction 100 & 1 000 ms, 60% reduction
Mains freq. 50 Hz	EN 61000-4-16	Signal ports	100 V 50 Hz line to earth
Mains freq. 50 Hz	SS 436 15 03	Signal ports	250 V 50 Hz line to line
Voltage dips and interruption	EN 61000-4-29	DC power ports	10 & 100 ms, interruption 10 ms, 30% reduction 10 ms, 60% reduction +20% above & -20% below rated voltage
Radiated emission	EN 55022	Enclosure	Class B
	FCC part 15		Class A
Conducted emission	EN 55022	AC power ports	Class B
	FCC part 15	AC power ports	Class A
	EN 55022	DC power ports	Class B
Dielectric strength	EN 60950	Signal port to all other isolated ports	2 kVrms 50 Hz 1min
		Power port to other isolated ports	3 kVrms 50 Hz 1min 2 kVrms 50 Hz 1min (@ rated power < 60V)
Environmental			
Temperature		Operating	-40 to +70°C
		Storage & Transport	-40 to +70°C
Humidity		Operating	5 to 95% relative humidity
		Storage & Transport	5 to 95% relative humidity
Altitude		Operating	2 000 m / 70 kPa
Service life		Operating	10 year
Vibration	IEC 60068-2-6	Operating	7.5 mm, 5 – 8 Hz 2 g, 8 – 500 Hz
Shock	IEC 60068-2-27	Operating	15 g, 11 ms
Packaging			
Enclosure	UL 94	PC / ABS	Flammability class V-1
Dimension W x H x D			35 x 121 x 119 mm
Weight			0.26 kg
Degree of protection			IP 21
Cooling	IEC 529	Enclosure	Convection
Mounting			Horizontal on 35 mm DIN-rail

Optical Power Budget for the ODW-series

The maximum supported link lengths as specified in table below should only be seen as indicative. The allowed link length is calculated from the Optical Power Budget (OPB), the available optical power for a fibre optic link, and the attenuation of the fibre, comprising losses due to in-line connectors, splices, optical switches and a margin for link aging (typical 1.5 dB for 1300 nm).

The worst-case Optical Power Budget (OPB) in dB for a fibre optic link is determined by the difference between the minimum transmitter output optical power and the lowest receiver sensitivity.

FX (Fibre)	SM-LC80	SM-LC40	SM-LC15	MM-LC2
Fibre connector	LC duplex	LC duplex	LC duplex	LC duplex
Fibre type	Singlemode 9/125 µm	Singlemode 9/125 µm	Singlemode 9/125 µm	Multimode, 62.5/125 and 50/125 µm
Wavelength	1550 nm	1310 nm	1310 nm	1310 nm
Transmitter Output optical power min/max	-5/0 dBm**	-5/0 dBm**	-15/-8 dBm**	-20/-14 dBm*
Receiver Input sensitivity, max	-34 dBm	-34 dBm	-31 dBm	-31 dBm
Receiver Input optical power, max	-5 dBm***	-3 dBm***	-8 dBm	-8 dBm
Optical power budget, worst-case	29 dB	29 dB	16 dB	11 dB
Bit error rate (BER)	$< 1 \times 10^{-10}$	$< 1 \times 10^{-10}$	$< 1 \times 10^{-10}$	$< 2.5 \times 10^{-10}$
Transceiver type	Small Form-Factor Pluggable (SFP) Multi-Sourcing Agreement (MSA) compliant			
Laser class	Class 1, IEC 825-1 Accessible Emission Limit (AEL)			

* Output power is power coupled into a 62.5/125 µm multimode fibre

** Output power is power coupled into a 9/125 µm singlemode fibre

*** The use of attenuation is recommended on short fibre lengths. 5dB (SM-LC80) and 3dB (SM-LC40)

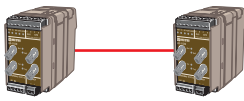
Power budget for the LR-series				
	Minimum budget			
	Fibre	820 nm		Singlemode
	50/125	10.7 dB		
	62,5/125	14.5 dB		
	100/140	20.6 dB		
	9/125			6.3 dB
	Typical Budget			
	50/125	16.6 dB		
	62,5/125	18.6 dB		
	100/140	25.9 dB		
9/125			12.3 dB	

"Min. budget" states the minimum guaranteed power budget.

Experience shows however that the typical value is in the range of the indicated "Typ. budget".

ODW-6xx-xx-xx

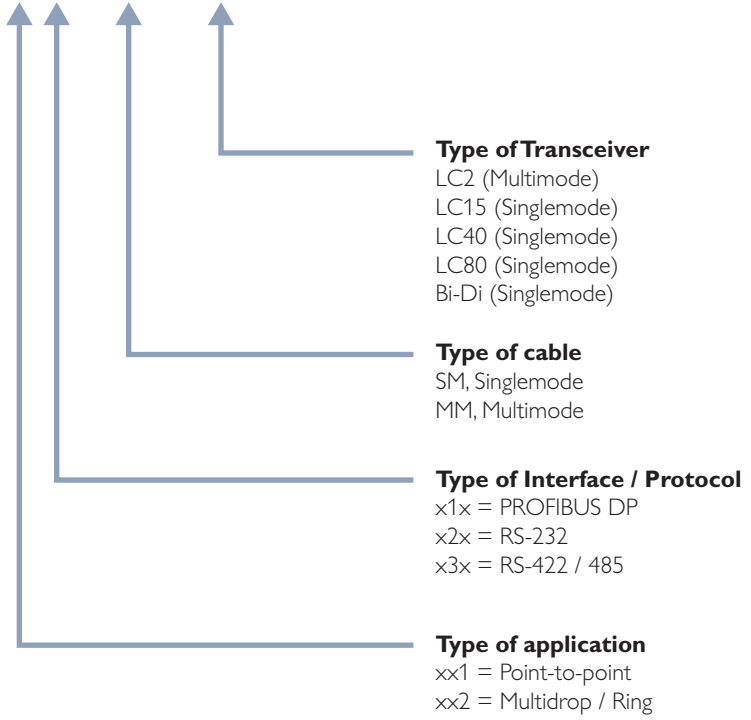

Different transceivers on the same modem

The ODW-xx2 modems allow for flexible transceiver configuration (LC15 and LC40 for instance). In order to get the installation to work is it of the utmost importance that transceivers are mounted in the right position / channel. For example in a ring application channel 1 must be connected to channel 2. In a multidrop application channel 1 should be connected to channel 2 except in the end unit where channel 1 should be used.

ODW-6xx-xx / xx-xx

