

- Timers
- Time Switches
- Counters
- Logic Controllers
- Protocol Converters
- Interface Converters
- Power Supplies
- Supply Monitoring Devices
- PID Controllers



General Industrial Controls Private Limited (GIC), is offering services as a well established manufacturer and exporter of Process Control and Automation products with unparalleled sophistication and expertise. We are an ISO 9001:2008, TS 16949 certified company with International approvals like cULus. Our products are Eco-friendly, RoHS compliant and CE certified. Brand "GIC" has been built on this strong foundation over the past three decades signifying reliability, quality and value for money.

Our product categories include **1) Lighting Automation:** Time Switches and Lighting Management Console **2) Process Control:** Timers, Mini PLCs, GSM Controller, Protocol Converters, Interface Converters, Power Supplies, PID Temperature Controllers **3) Low Voltage Protection and Switchgear:** Voltage Protection, Frequency, Thermistor & Earth Leakage Relays **4) Instrumentation:** Hour Meters, Impulse Counters and **5) Injection Moulded Plastic Components** for various applications.



INDEX

CONTENTS	PAGE NOS.
TIMERS	03
Digital Timer <i>Elivo</i> [®]	04-10
Electronic Timer - Series Staircase	11-12
Electronic Timer - Series Micon [®] 175	13-17
Electronic Timer - Series Micon [®] 225	18-25
Motor Control Timers	26-29
Synchronous Timer - Series EM 1000	30
Synchronous Timer - Series EM 2000	31-32
Basic Operating Modes / Functions	33
TIME SWITCHES	35
Time Switch FM Series	36
Digital Time Switch <i>Crono</i> [®] & <i>Pulse</i>	37
Astronomical Time Switch <i>Astro</i> [®] <i>Mini</i>	38
Astronomical Time Switch <i>Astro</i> [®]	39-40
Lighting Automation with <i>Astro</i> [®] Using GSM Technology	41-42
HOOR METERS & COUNTERS	43
Hour Meter Series HM 36	44-47
Digital Hour Meter & Counter	48-49
Digital Hour Meters	50-51
Impulse Counter Series CR 18	52-53
Impulse Counter Series CR 26	54-55
Impulse Counter Series CR 36	56
Digital Counters	57-60
CONTROLLERS	61
Programmable Logic Controllers	
Smart Relay <i>Genie</i> [™] - <i>AX</i>	62-64
GSM Controller	65-66
PROTOCOL CONVERTERS	67
<i>Lynx</i> Gateway	68-69
INTERFACE CONVERTERS	71
USB to RS232 / RS485 / RS422 Converter	72
RS232 to RS485 / RS422 Converter	73
POWER SUPPLIES	75
Switched Mode Power Supply	76-77
SUPPLY MONITORING DEVICES	79
Supply Monitoring Series SM 301	80
Supply Monitoring Series SM 500	81-83
Supply Monitoring Series SM 501	84-85
Supply Monitoring Series SM 175	86-88
Supply Monitoring Series - Three Phase Indicator	89
Frequency Monitoring Series PD 225	90
PTC Thermistor Relay Series PD 225	91
PTC Thermistor & Single Phasing Preventer Series PD225	92-93
Supply Monitoring Series CMR - Current Control	94-96
Earth Leakage Relay Series CMR	97-101
TEMPERATURE CONTROLLERS	103
PID Temperature Controller Series PR 69	104-106
ON-OFF Temperature Controller Series PR 433 & PR 434	107-108

TIMERS

Digital Timer *Eliso*[®] 17.5 mm

Programmable Digital Timer *Eliso*[®] 48 mm x 48 mm

Electronic Timer - Series Staircase

Electronic Timer - Series Micon[®] 175

Electronic Timer - Series Micon[®] 225

Motor Control Timers

Synchronous Timer - Series EM 1000

Synchronous Timer - Series EM 2000

Basic Operating Modes / Functions

Digital Timer *Eliro*®

- Compact 17.5 mm Wide
- Multi Function: (8 or 18) Non Signal & Signal based functions
- Multi-Voltage: 24 - 240 VAC/DC
- Wide Timing Range: 0.1s to 999 Hr
- 3 Digit LCD for Preset time and Run time
- Option to select Up/Down counting
- Tamper proof with key lock feature



Cat. No.	V0DDTS	V0DDTD	V0DDTS1	V0DDTD1	
Parameters					
Timer Description	Multi Function Digital Timer				
Functions	1) ON Delay 2) Cyclic OFF/ON 3) Cyclic ON/OFF 4) Signal ON/OFF 5) Signal OFF Delay 6) Interval 7) Signal OFF/ON 8) One Shot Output		1) ON Delay 2) Cyclic OFF/ON 3) Cyclic ON/OFF 4) Impulse on Energizing 5) Accumulative Delay on Signal 6) Accumulative Delay on Inverted Signal 7) Accumulative Impulse on Signal 8) Signal ON Delay 9) Inverted Signal ON Delay 10) Signal OFF Delay 11) Impulse ON/OFF 12) Signal OFF/ON 13) Leading Edge Impulse 1 14) Leading Edge Impulse 2 15) Trailing Edge Impulse 1 16) Trailing Edge Impulse 2 17) Delayed Impulse 18) Inverted Signal ON Delay		
Supply Voltage (φ)	24 - 240 VAC/DC				
Supply Variation	-15% to +10% (of φ)				
Frequency	50/60 Hz				
Power Consumption (Max.)	0.5 VA (@ 24/48 VAC), 4 VA (@ 110 to 265 VAC/DC)				
Timing Range	0.1s to 999h				
Reset Time	200 ms (Max.)				
Repeat Accuracy	± 0.5%				
Output	Relay Output	1 C/O	2 NO	1 C/O	2 NO
	Contact Rating	8A @ 240 VAC / 24 VDC (Resistive)			
	Electrical Life	1x10 ⁵			
	Mechanical Life	2x10 ⁷			
Utilization Category	AC - 15	Rated Voltage (Ue): 125/240 V, Rated Current (Ie): 3/1.5 A			
	DC - 13	Rated Voltage (Ue): 125/250 V, Rated Current (Ie): 2/0.22/0.1 A			
Operating Temperature	-10° C to +55° C				
Storage Temperature	-20° C to +65° C				
Humidity (Non Condensing)	95% (Rh)				
LED Indication	Red LED → Relay ON				
Enclosure	Flame Retardant UL94-V0				
Dimension (W x H x D) (in mm)	17.5 X 89 X 76				
Weight (unpacked) Approx.	85 g				
Mounting	Base / DIN Rail				
Certification					
Degree of Protection	IP 20 for Terminals, IP 30 for Enclosure				
EMI / EMC					
Harmonic Current Emissions	IEC 61000-3-2	Ed. 3.2 (2009-04) Class A			
ESD	IEC 61000-4-2	Ed. 2.0 (2008-12) Level II			
Radiated Susceptibility	IEC 61000-4-3	Ed. 3.2 (2010-04) Level III			
Electrical Fast Transients	IEC 61000-4-4	Ed. 3.0 (2012-04) Level IV			
Surges	IEC 61000-4-5	Ed. 2.0 (2005-11) Level IV			
Conducted Susceptibility	IEC 61000-4-6	Ed. 3.0 (2008-10) Level III			
Voltage Dips & Interruptions (AC)	IEC 61000-4-11	Ed. 2.0 (2004-03) All 7 Levels			
Voltage Dips & Interruptions (DC)	IEC 61000-4-29	Ed. 1.0 (2000-08) All 5 Levels			
Conducted Emission	CISPR 14-1	Ed. 5.2 (2011-11) Class A			
Radiated Emission	CISPR 14-1	Ed. 5.2 (2011-11) Class B			
Environmental					
Cold Heat	IEC 60068-2-1	Ed. 6.0 (2007-03)			
Dry Heat	IEC 60068-2-2	Ed. 5.0 (2007-07)			
Vibration	IEC 60068-2-6	Ed. 7.0 (2007-12) 5g			
Repetitive Shock	IEC 60068-2-27	Ed. 4.0 (2008-02) 40g, 6ms			
Non-Repetitive Shock	IEC 60068-2-27	Ed. 4.0 (2008-02) 30g, 15ms			

ORDERING INFORMATION

Cat. No.	Description
V0DDTS	24 - 240 VAC/DC, Multi Function Digital Timer - Eliro (8 Functions), 1 C/O
V0DDTD	24 - 240 VAC/DC, Multi Function Digital Timer - Eliro (8 Functions), 2 NO
V0DDTS1	24 - 240 VAC/DC, Multi Function Digital Timer - Eliro (18 Functions), 1 C/O
V0DDTD1	24 - 240 VAC/DC, Multi Function Digital Timer - Eliro (18 Functions), 2 NO



FUNCTIONAL DIAGRAMS FOR V0DDTS & V0DDTD

⏏ : Supply Voltage, S: Input Signal, R: Relay Output
 T: Preset Time, TON: Preset ON Time, TOFF: Preset OFF Time

ON DELAY (A)

On application of supply voltage, the preset time duration (T) starts. On completion of the preset time, the output is switched ON and remains ON till the supply voltage is present

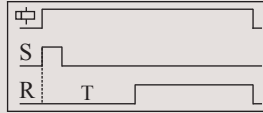

CYCLIC OFF/ON {OFF Start, (Sym, Asym)} (b)

On application of supply voltage, the output is initially switched OFF for the preset 'OFF' time duration (TOFF) after which it is switched ON for the preset 'ON' time duration (TON). This cycle repeats and continues till the supply is present.



CYCLIC ON/OFF {ON Start, (Sym, Asym)} (C)

On application of supply voltage, the output is initially switched ON for the preset 'ON' time duration (TON) after which it is switched OFF for the preset 'OFF' time duration (TOFF). This cycle repeats and continues till the supply is present.

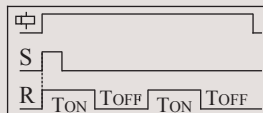

SIGNAL ON/OFF (d)

On application of signal the preset time (T) starts. After this preset time has elapsed, output is switched ON. If signal is removed then output is switched ON immediately and OFF delay is started. Once this time period has elapsed the output is switched OFF. During this OFF delay if signal is reapplied the output switched OFF immediately and ON Delay restarted.

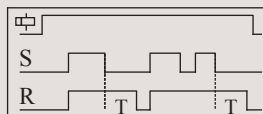

SIGNAL OFF DELAY (E)

On application of supply voltage and input signal, the output is switched ON. When the signal is removed the preset time duration commences & the output is switched OFF at the end of the time duration.

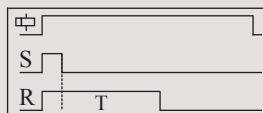

INTERVAL (F)

When supply power is applied to the timer and on application of input signal the output is immediately switched ON. The output remains ON for the preset time duration (T) after which it is switched OFF.

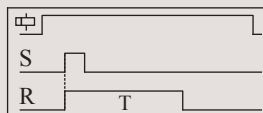

SIGNAL OFF / ON (G)

On application of input signal, the preset delay time period (T) starts. On completion of the preset time, the output is switched ON. On removal of input signal, the preset time period starts again and the output is switched ON when the preset time duration is complete.

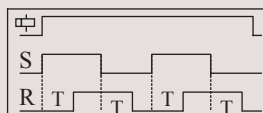

ONE SHOT OUTPUT (H)

When Signal (S) is applied, the Timer Duration (T) starts. At the end of Timer duration (T), the relay gets energized for approximately 1 sec. (Refer Note : 2)

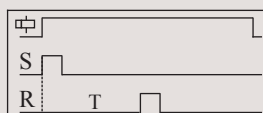

- Note:
1. For Power-On operation, connect the terminal B1 to A1 permanently.
 2. If the Signal (S) changes during the Timer Duration (T), it does not change the output relay but re-triggering takes places and the Timer Duration is extended.



FUNCTIONAL DIAGRAMS FOR V0DDTS1 & V0DDTD1

⏏ : Supply Voltage, S: Input Signal, R: Relay Output
T: Preset Time, TON: Preset ON Time, TOFF: Preset OFF Time

ON DELAY [0]

On application of supply voltage, the preset time duration (T) starts. On completion of the preset time, the output is switched ON and remains ON till the supply voltage is present.

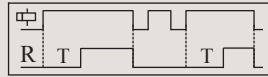

SIGNAL OFF DELAY [9]

On application of supply voltage and input signal, the output is switched ON. When the signal is removed the preset time duration commences & the output is switched OFF at the end of the time duration.

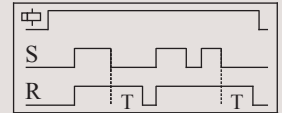

CYCLIC OFF/ON {OFF Start, (Sym, Asym)} [1]

On application of supply voltage, the output is initially switched OFF for the preset 'OFF' time duration (TOFF) after which it is switched ON for the preset 'ON' time duration (TON). This cycle repeats and continues till the supply is present.



IMPULSE ON/OFF [A]

On application or removal of input signal, the output is switched ON & the preset time duration (T) starts. On completion of the time duration the output is switched OFF. When timing commences, changing the state of the input signal resets the time.

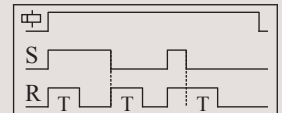

CYCLIC ON/OFF {ON start, (Sym, Asym)} [2]

On application of supply voltage, the output is initially switched ON for the preset 'ON' time duration (TON) after which it is switched OFF for the preset 'OFF' time duration (TOFF). This cycle repeats and continues till the supply is present.



SIGNAL OFF/ON [b]

On application of input signal, the preset delay time period (T) starts. On completion of the preset time, the output is switched ON. On removal of input signal, the preset time period starts again and the output is switched ON when the preset time duration is complete.

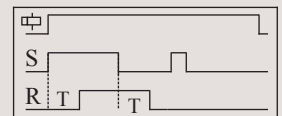

IMPULSE ON ENERGIZING [3]

On application of supply voltage, the output is instantly switched ON for the preset time duration (T) after which it is switched OFF.

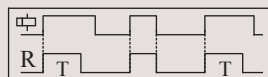

LEADING EDGE IMPULSE1 [C]

On application of input signal the output is immediately switched ON. The output remains ON for the preset time duration (T) after which it is switched OFF. If the input signal is removed during the preset time, the output remains unaffected.

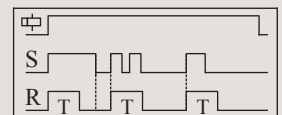

ACCUMULATIVE DELAY ON SIGNAL [4]

On application of supply voltage, the preset timing duration commences. When input signal is applied, the timing pauses and resumes only when the input signal is removed. The output is switched ON at the end of the preset time duration (T).

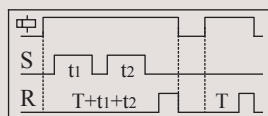

LEADING EDGE IMPULSE2 [d]

On application of input signal the output is immediately switched ON. The output remains ON for the preset time duration (T) after which it is switched OFF. If the input signal is removed during the preset time, the output is immediately switched OFF.

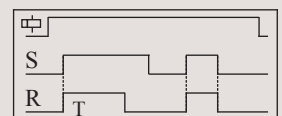

ACCUMULATIVE DELAY ON INVERTED SIGNAL [5]

On application of supply voltage and input signal, the preset timing duration commences. When the signal is removed the timing pauses and resumes when the signal is applied. The output is switched ON at the end of the preset time duration (T).

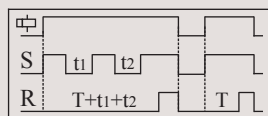

TRAILING EDGE IMPULSE1 [E]

When the input signal to the timer is removed, the output is immediately switched ON for the preset time duration (T) after which it is switched OFF. If the input signal is applied during the preset time, the output is immediately switched OFF.

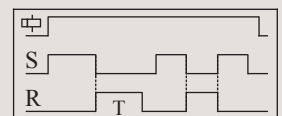

ACCUMULATIVE IMPULSE ON SIGNAL [6]

On application of supply voltage the output is switched ON & the preset timing duration commences. When the signal is applied the timing pauses and resumes when the signal is removed. The output is switched OFF at the end of the preset time duration (T).

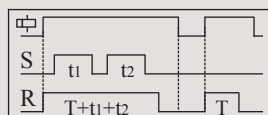

TRAILING EDGE IMPULSE2 [F]

When the input signal to the timer is removed, the output is immediately switched ON for the preset time duration (T) after which it is switched OFF. If the input signal is applied during the preset time, the output remains unaffected.

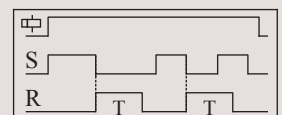

SIGNAL ON DELAY [7]

On application of input signal, the preset time duration (T) starts. On completion of the preset time, the output is switched ON and remains ON till the input signal is present.

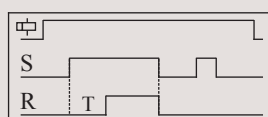

DELAYED IMPULSE [G]

On application of input signal, the preset 'OFF' time duration (TOFF) starts. the output is switched ON at the end of the preset 'OFF' time duration & the preset 'ON' time duration commences irrespective of signal level and remains ON till the completion of 'TON'.

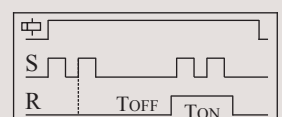

INVERTED SIGNAL ON DELAY [8]

On application of supply voltage, the preset time duration (T) starts. When input signal is applied, the timing pauses & resumes only when the signal is removed. On completion of the preset time, the output is switched ON.



INVERTED SIGNAL ON DELAY-TYPE 2 [H]

Timing starts only upon signal 'S' transition high to low. During timing or after completion of Time (i.e. relay on), any signal transition is ignored. To reset the timer supply has to be interrupted.

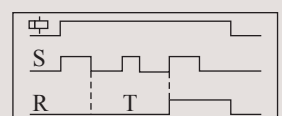

Programmable Digital Timer *Eliro*[®]

- Digital 7-Segment display Supply Voltage range of 110-240 VAC
- Input Signal Sensing range of 85-265 VAC/100-265 VDC & 20-60 VAC/DC
- Inbuilt library of 33 functions covering majority applications
- Easy steps to program customized functions
- Suitable for Panel and Base/DIN mounting
- Two separate Channel outputs with selectable Timer modes
- Wide timing range - 0.1 Sec. to 999 Days
- Tamper proof with key lock feature
- Provision to edit Preset time during Run time
- Provision to save two independent functional Profiles (P1 & P2)



Cat. No.	V7DFTS3	V7DDSS3
Parameters	Programmable Multi Function Digital Timer	
Timer Description	Programmable Multi Function Digital Timer	
Default Functions	1) On delay 2) On delay constant supply type 2 3) On delay constant supply type 3 4) On delay (control switch resettable) 5) Signal on delay 6) Inverted signal on delay 7) Inverted signal on delay type 2 8) Signal off delay 9) Off delay const. supply type 2 10) Cyclic on/off 11) Cyclic off/on 12) Asymmetric cycle pulse start 13) Asymmetric recycler pulse start type 2 14) Signal on off delay 15) Signal on off delay type 2 16) Signal off/on (new)	17) Impulse on energizing 18) Impulse on/off 19) Accumulative delay on signal 20) Accumulative delay on inverted signal 21) Accumulative impulse on signal 22) Leading edge impulse 23) Leading edge impulse 2 24) Trailing edge impulse 25) Trailing edge impulse 2 26) Delayed impulse 27) Delayed impulse type 2 28) Delayed pulse (constant supply) 29) Delayed pulse (remote trig.) 30) Delayed pulse (const. supply type 1) 31) On pulse (control switch resettable) 32) On pulse (supply reset)mode 33) Leading edge bi-stable or step relay
Supply Voltage (φ)	110 - 240 VAC	
Supply Variation	-20% to +10% (of φ)	
Frequency	47-63 Hz	
Power Consumption (Max.)	9 VA	
Timing Range	0.1s to 999 days	
Reset Time/Initiate Time	200 ms (Max.) / 100 ms (Max.)	
Input Signals/Signal Isolation	High Range: 85-265V AC/ 100-265V DC, Low Range: 24-60V AC/DC / 2 KV	
Signal Sensing Time/ Wait Period	50ms. (max.) / 100ms @ Power On & for signal based modes only.	
Timing Accuracy	± 0.01%	
Output	Relay Output	2 C/O
	Contact Rating	5A for NO & 3A for NC @ 250VAC/30VDC (Resistive.)
	Electrical Life	1x10 ⁵
	Mechanical Life	5x10 ⁶
Utilization Category	AC - 15	250V AC/2A, Cos Ø = 0.6, 85°C, 100000 Operations.
	DC - 13	Ue rated voltage V – 24; Ie rated current A – 2.0.
Operating Temperature	-5° C to +55° C	
Storage Temperature	-10° C to +60° C	
Humidity (Non Condensing)	95% (Rh)	
LED Indication	SV (Red) - Set Value; P1/P2 (Red) -P1 Running; Up/Down (Red)-Up Counting; SG (Green)- Signal Present; OP1 (Red)-Relay OP1 ON; OP2 (Red)-Relay OP2 ON;	
Enclosure	IP 30 for Housing & front Facial and IP 20 for Terminals	
Dimension (W x H x D) (in mm)	48 X 48 X 92.5	
Weight (unpacked)	160 g	
Mounting	Panel / Flush Mountable	Base / DIN Rail with 11 Pin Universal socket
Certification		
Degree of Protection	IP 20 for Terminals, IP 30 for Enclosure	
EMI / EMC		
Harmonic Current Emissions	IEC 61000-3-2	Ed. 3.2 (2009-04) Class A
ESD	IEC 61000-4-2	Ed. 2.0 (2008-12) Level II
Radiated Susceptibility	IEC 61000-4-3	Ed. 3.2 (2010-04) Level III
Electrical Fast Transients	IEC 61000-4-4	Ed. 3.0 (2012-04) Level IV
Surges	IEC 61000-4-5	Ed. 2.0 (2005-11) Level IV
Conducted Susceptibility	IEC 61000-4-6	Ed. 3.0 (2008-10) Level III
Voltage Dips & Interruptions (AC)	IEC 61000-4-11	Ed. 2.0 (2004-03) All 7 Levels
Voltage Dips & Interruptions (DC)	IEC 61000-4-29	Ed. 1.0 (2000-08) All 5 Levels
Conducted Emission	CISPR 14-1	Ed. 5.2 (20011-11) Class A
Radiated Emission	CISPR 14-1	Ed. 5.2 (20011-11) Class B
Environmental		
Cold Heat	IEC 60068-2-1	Ed. 6.0 (2007-03)
Dry Heat	IEC 60068-2-2	Ed. 5.0 (2007-07)
Vibration	IEC 60068-2-6	Ed. 7.0 (2007-12) 5g
Repetitive Shock	IEC 60068-2-27	Ed. 4.0 (2008-02) 40g, 6ms
Non-Repetitive Shock	IEC 60068-2-27	Ed. 4.0 (2008-02) 30g, 15ms

ORDERING INFORMATION

Cat. No.	Description
V7DFTS3	110 - 240 VAC, Multi Function Digital Timer - Eliro (33 Functions), 2 C/O
V7DDSS3	110 - 240 VAC, Multi Function Digital Timer - Eliro (33 Functions), 2 C/O, 11 Pin Universal socket



FUNCTIONAL DIAGRAMS

☐ : Supply Voltage, S: Input Signal, R: Relay Output

T: Preset Time, TON: Preset ON Time, TOFF: Preset OFF Time, T-a: Timing Break Before completion

ON DELAY [00]

On application of supply voltage, the preset time duration (T) starts. On completion of the preset time, the output is switched ON and remains ON till the supply voltage is present.

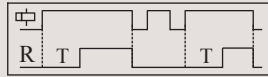

SIGNAL OFF DELAY [07]

On application of supply voltage and input signal, the output is switched ON. When the signal is removed the preset time duration commences & the output is switched OFF at the end of the time duration.

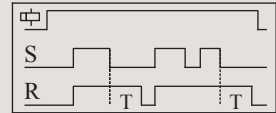

ON DELAY CONSTANT SUPPLY TYPE 2 [01]

Timing will commence when the supply is present and input signal is not applied. After the time period has elapsed, output is switched ON. If signal is applied then the timing period stops. Timing will restart only when signal is removed. Therefore there are two methods this timer can be controlled, either by application or removal of signal input and with the interruption of the supply voltage to the timer with signal removal.

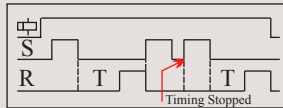

OFF DELAY CONST. SUPPLY TYPE 2 [08]

A permanent supply is required. When the input signal is applied the output is switched ON immediately. When input signal is removed the timing period starts. After the time period has elapsed output is switched OFF. Once the timing period has started further actions of input signal will have no effect. However once the timing cycle has been completed the process may be started again applying input signal. While the timer is executing the only way to reset the timer is to interrupt the supply.

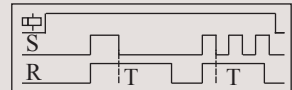

ON DELAY CONSTANT SUPPLY TYPE 3 [02]

A permanent supply is required. The timing period starts when the signal is applied and will continue irrespective of any further changes to signal input. After the time period has elapsed output is switched ON. Signal change has no effect during timing period. To reset the timer, signal must be removed and then applied.

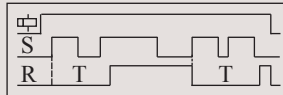

CYCLIC ON/OFF {ON start, (Sym, Asym)} [09]

On application of supply voltage, the output is initially switched ON for the preset 'ON' time duration (TON) after which it is switched OFF for the preset 'OFF' time duration (TOFF). This cycle repeats and continues till the supply is present.



ON DELAY (CONTROL SWITCH RESETTABLE) [03]

When the supply is connected and signal is applied, the timing function starts. If signal is removed and applied during the preset timing then timing is restarted and output stays OFF. After preset time has elapsed the output is ON.

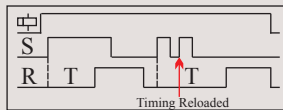

CYCLIC OFF/ON {OFF Start, (Sym, Asym)} [10]

On application of supply voltage, the output is initially switched OFF for the preset 'OFF' time duration (TOFF) after which it is switched ON for the preset 'ON' time duration (TON). This cycle repeats and continues till the supply is present.



SIGNAL ON DELAY [04]

On application of input signal, the preset time duration (T) starts. On completion of the preset time, the output is switched ON and remains ON till the input signal is present.

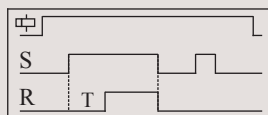

ASYMMETRIC CYCLE PULSE START [11]

A permanent supply is required. The timer function is triggered by the input signal. When input signal applied the output is switched ON while the first preset time period (TON) elapses. Once this time period (TON) has elapsed output is switched OFF for the second preset time period (TOFF) period. Once this second time period (TOFF) had elapsed then output switched ON and the cycle will start from the beginning again. If input signal is removed during timing (TON or TOFF) the cycle will stop and output is switched OFF, cycle will start with output ON state when the input signal applied again.

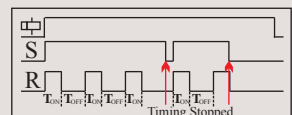

INVERTED SIGNAL ON DELAY [05]

On application of supply voltage, the preset time duration (T) starts. When input signal is applied, the timing pauses & resumes only when the signal is removed. On completion of the preset time, the output is switched ON.

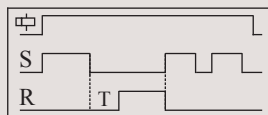

ASYMMETRIC RECycler PULSE START TYPE 2 [12]

A permanent supply is required. The timer function is triggered by input signal. When input signal is applied the output is switched OFF while the first preset time period (TOFF) elapses. Once this time period (TOFF) has elapsed output is switched ON for the second preset time period (TON). Once this second time period (TON) had elapsed then output is switched OFF and the cycle will start from the beginning again. If input signal is removed during timing (TON or TOFF) the cycle will stop and output is switched OFF, cycle will start with output OFF state when the input signal applied again.

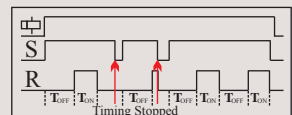

INVERTED SIGNAL ON DELAY-TYPE 2 [06]

Timing starts only upon signal 'S' transition high to low. During timing or after completion of Time (i.e. relay on), any signal transition is ignored. To reset the timer supply has to be interrupted.

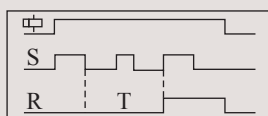

SIGNAL ON OFF DELAY [13]

On application of signal the preset time (T) starts. After this preset time has elapsed, output is switched ON. During this timing, if signal is removed then output is switched ON immediately and OFF delay is started. Once this time period has elapsed the output is switched OFF. During this OFF delay if signal is reapplied the output switched OFF immediately and ON Delay restarted.

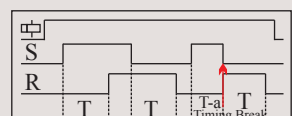



FUNCTIONAL DIAGRAMS

DELAYED PULSE (REMOTE TRIG.) [28]

The timing period (TOFF) will start when input signal is applied with the supply connected. After preset time (TOFF) has elapsed the output is switched ON for the pre-selected pulse (TON) duration. To reset the timer either input signal needs to be removed or supply has to interrupt. If this action occurs during the pulsed output cycle (TON) then output is switched OFF and the timer will reset.

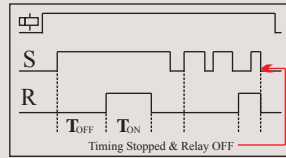

☐: Supply Voltage, S: Input Signal, R: Relay Output
T: Preset Time, TON: Preset ON Time, TOFF: Preset OFF Time

ON PULSE (CONTROL SWITCH RESETTABLE) / WATCH DOG TYPE [30]

When the supply is connected and signal is applied, output is switched ON and the timing function starts. If signal is removed and applied during the preset timing then timing is restarted and output stays ON. After preset time (TON) has elapsed the output is switched OFF.

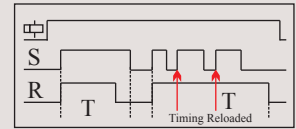

DELAYED PULSE (CONST. SUPPLY TYPE 1) [29]

Supply to the unit must be continuous. On application of input signal the time period 'TOFF' starts to run. On completion of 'TOFF', the relay output is switched ON immediately and the time period 'TON' starts to run. On completion of 'TON' the output is switched OFF. The input signal has no effect until 'TOFF' + 'TON' have completely expired.

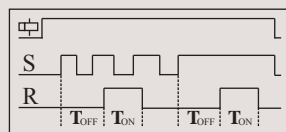

ON PULSE (SUPPLY RESET)[31]

On application of supply voltage the output is switched ON. The first pulse of input signal starts the preset time period. Receiving pulses during the time period extends it and output stays ON. Receiving no signal pulses during the time period completes it and output is switched OFF. Output stays OFF until supply voltage has been interrupted.

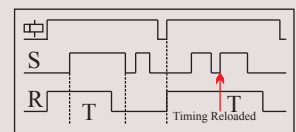

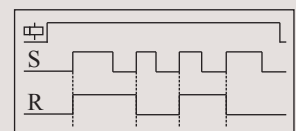

LEADING EDGE BI-STABLE OR STEP RELAY [32]

After every signal, the output contact changes their states, alternately switching from open to close and vice versa.

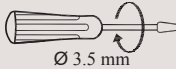

TERMINAL TORQUE & CAPACITY

	Torque - 0.50 N.m (3.5 Lb.in) Terminal screw - M3
	Solid Wire - 1 X 0.12...2 mm ²
AWG	1X26 to 14

CONNECTION DIAGRAM

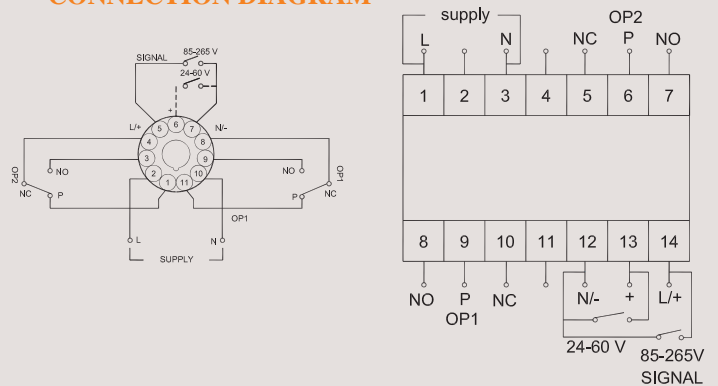

DIN / SOCKET / BASE MOUNT

PANEL / FLUSH MOUNT

MOUNTING DIMENSIONS (mm)

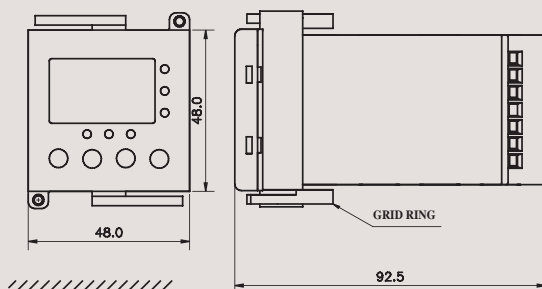

V7DFTS3

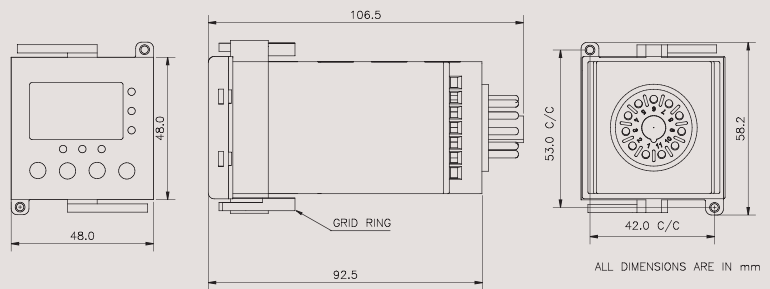

V7DDSS3

ALL DIMENSIONS ARE IN mm

Electronic Timer - Series Staircase

- Multi Function/Mono Function Staircase Timer in compact 17.5mm
- Time Range: 0.5min - 20min
- Long Run mode with Time range from 0.5h - 20h
- Functions with Pre-Warning, Cut-Off & Release Delay
- Maintenance Mode available
- Switch indications (Glow-lamps / Pilot lamps) upto 50 mA
- 3 Wire & 4 Wire Configurations



Cat. No.		27B1C3B1
Parameters		
Timer Description		Staircase Timer
Modes	1) Staircase Relay 2) Staircase Relay with Pre-Warning 3) Staircase Relay with Cut-Off 4) Staircase Relay with Cut-Off & Pre-Warning 5) Timing Step with Release Delay & Cut-Off 6) Timing Step with Release Delay, Cut-Off & Pre-Warning 7) Long Run 8) Long Run with Pre-Warning 9) Step Relay 10) Permanent ON 11) Maintenance Mode	
Supply Voltage (ϕ)	230 VAC	
Supply Variation	- 25% to +15% (of ϕ)	
Frequency	50 Hz	
Power Consumption (Max.)	3 VA	
Timing Ranges	0.5m, 2m, 4m, 6m, 9m, 15m, 20m (The unit will change from minutes to hours for 'Long Run' modes)	
Reset Time	500 ms (Max.)	
Signal Sensing Time	40 ms < Ts < 5 s (For modes 1, 2, 3, 4, 5, 6, 9) & Ts = 5s (For modes 7, 8, 11)	
Maintenance Mode	If the Relay is 'OFF' and the signal is present for 5 sec or more (Ts = 5 s), the timer will enter 'Maintenance mode'	
Setting Accuracy	± 5% of Marking	
Repeat Accuracy	± 1%	
Output	Relay Output	1 NO (Pole is internally shorted with 'Live')
	Contact Rating	16A @ 230 VAC (Resistive)
	Electrical Life	1X10 ⁵
	Mechanical Life	5X10 ⁶
Utilization Category	AC - 15	Rated Voltage (Ue): 120/240 V, Rated Current (Ie): 3.0/1.5 A
	DC - 13	Rated Voltage (Ue): 24/125/250 V, Rated Current (Ie): 2.0/0.22/0.1 A
Operating Temperature	-10°C to +60°C	
Storage Temperature	-15°C to +70°C	
LED Indication	Green LED → Power ON, Yellow LED → Relay ON	
Enclosure	Flame Retardant UL94-V0	
Dimension (W x H x D) (in mm)	18 X 85 X 65	
Weight (unpacked)	70 g	
Mounting	Base / DIN Rail	
Certification		
Degree of Protection	IP 20 for Terminals, IP 40 for Enclosure	
EMI / EMC		
Harmonic Current Emissions	IEC 61000-3-2	Ed. 3.2 (2009-04) Class A
ESD	IEC 61000-4-2	Ed. 2.0 (2008-12) Level II
Radiated Susceptibility	IEC 61000-4-3	Ed. 3.2 (2010-04) Level III
Electrical Fast Transients	IEC 61000-4-4	Ed. 3.0 (2012-04) Level IV
Surges	IEC 61000-4-5	Ed. 2.0 (2005-11) Level IV
Conducted Susceptibility	IEC 61000-4-6	Ed. 3.0 (2008-10) Level III
Voltage Dips & Interruptions (AC)	IEC 61000-4-11	Ed. 2.0 (2004-03) All 7 Levels
Voltage Dips & Interruptions (DC)	IEC 61000-4-29	Ed. 1.0 (2000-08) All 5 Levels
Conducted Emission	CISPR 14-1	Ed. 5.2 (20011-11) Class B
Radiated Emission	CISPR 14-1	Ed. 5.2 (20011-11) Class A
Environmental		
Cold Heat	IEC 60068-2-1	Ed. 6.0 (2007-03)
Dry Heat	IEC 60068-2-2	Ed. 5.0 (2007-07)
Vibration	IEC 60068-2-6	Ed. 7.0 (2007-12) 5g
Repetitive Shock	IEC 60068-2-27	Ed. 4.0 (2008-02) 40g, 6ms
Non-Repetitive Shock	IEC 60068-2-27	Ed. 4.0 (2008-02) 30g, 15ms

ORDERING INFORMATION

27				3	B	
Casing Colour		Mode		Output Relay Contact		
B	Casing: White & Knob: Red	1	C	Multi Mode	1	1 'NO', 16A, 120A/20ms (Peak Inrush Current)
C	Casing: Dark Grey & Knob: Green	2	B	Mono Mode	2	1 'NO', 16A, 80A/20ms (Peak Inrush Current)

* For Mono Mode the available mode is 'Timing Step with Release Delay & Cut-Off'

FUNCTIONAL DIAGRAM

S: Supply, R: Relay Output, T: Preset Time, t: 10 seconds

1. STAIRCASE RELAY

On initial signal, the output closes & timing starts for the preset duration. Subsequent signals during the run time will extend the time duration by the full preset value.

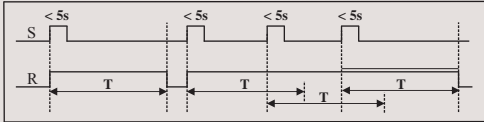

2. STAIRCASE RELAY WITH PRE-WARNING

On Initial Signal, the output is switched ON & timing starts for the preset duration. On completion of the set time duration the output blinks once & after a delay of 10 seconds, it blinks twice. After a further delay of 10 seconds, the output is switched OFF. Any signal during the run time or the pre-warning period will extend the time duration by the value indicated on the timer during run time.

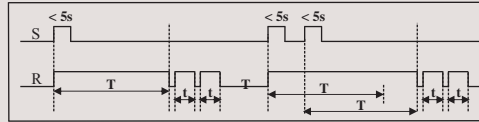

3. STAIRCASE RELAY WITH CUT-OFF

On initial signal, the output closes & timing starts for the preset duration. Subsequent signals during the run time will extend the time duration by the full preset value. If a signal of duration more than 2 seconds is applied, the output contacts open instantly.

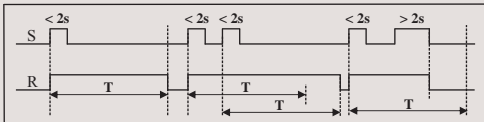

4. STAIRCASE RELAY WITH CUT-OFF & PRE-WARNING

On Initial Signal, the output is switched ON & timing starts for the set duration. On completion of the set time duration the output blinks once & after a delay of 10 seconds, it blinks twice. After a further delay of 10 seconds, the output is switched OFF. Any signal during the run time or the pre-warning period will extend the time duration by the value indicated on the timer during run time. If a signal of duration 2 seconds or more is applied, then the output is switched OFF after completion of the pre-warning period.

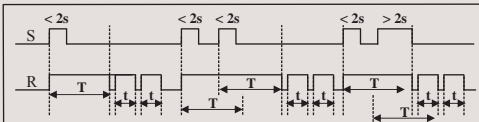

5. TIMING STEP WITH RELEASE DELAY & CUT-OFF

On initial signal, the output closes & timing starts for the preset duration. During run time, if a signal of duration less than 2 seconds is applied, it is ignored. If the duration is more than 2 seconds, the output contacts open instantly.

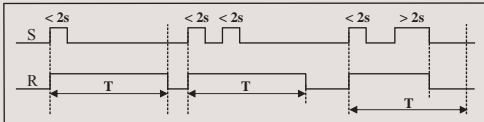

6. TIMING STEP WITH RELEASE DELAY & CUT-OFF & PRE-WARNING

On Initial Signal, the output is switched ON & timing starts for the set duration. On completion of the set time duration the output blinks once & after a delay of 10 seconds, it blinks twice. After a further delay of 10 seconds, the output is switched OFF. Any signal during the run time or the pre-warning period will extend the time duration by the value indicated on the timer during run time. If a signal of duration 2 seconds or more is applied, then the output is switched OFF after completion of the pre-warning period.

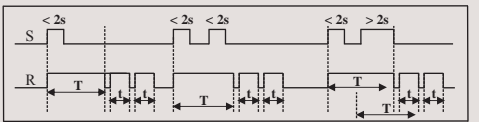

7. LONG RUN

On initial signal, the output closes & timing starts for the preset duration. On completion of the time duration the output contacts open. Any signal during the run time is ignored.

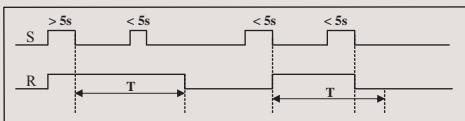

8. LONG RUN WITH PRE-WARNING

On Initial Signal, the output is switched 'ON' & timing starts for the preset duration. On completion of the set time duration the output blinks once & after a delay of 10 seconds, it blinks twice. After a further delay of 10 seconds, the output is switched OFF. During run time, if a signal of duration less than 5 seconds is applied, it is ignored. If the duration of the signal is 5 seconds or more, then output is switched OFF after completion of the pre warning period.

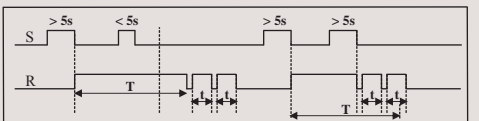

9. STEP RELAY

After every signal, the output changes state, alternately switching from open to closed & vice versa.

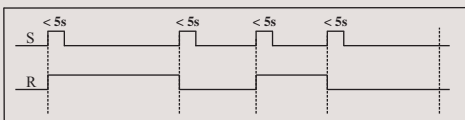

10. PERMANENT ON

In this mode the output contacts are permanently closed until the mode is changed and the device is reset.

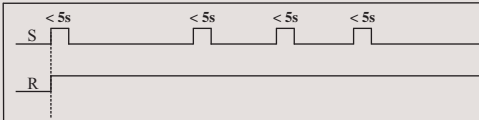

11. MAINTENANCE MODE

If the relay is OFF and a signal of duration more than 5 seconds is applied, the maintenance mode is activated. In this mode the output contacts close for a duration of 60 minutes after which it opens. During this period if a signal of duration more than 5 seconds is applied, the maintenance mode is interrupted and the output contacts open. The mode can be activated from any one of the modes (Mode 1, 2, 3, 4, 5, 6, 9) provided that the output contacts are open initially.

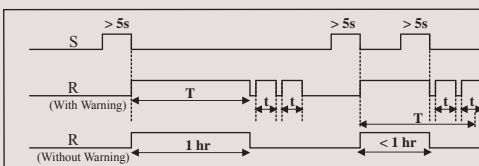

Pre-Warning: On completion of the set time duration the output blinks once & again blinks twice after a delay of 10 seconds and the contacts open after a further delay of 10 seconds.

Electronic Timer - Series Micon® 175

- Compact 17.5mm Wide
- Integrated Dual Voltage
- Functions: ON Delay, Star Delta, One Shot
- Wide Time Range: 0.3s - 30h
- LED Indications for Power and Relay status
- Low Power Consumption



Cat. No.	12ODT4		12SDT0
Parameters			
Timer Description	ON Delay Timer		Star Delta Timer
Mode	ON Delay		Star Delta
Functional Diagram			
Supply Voltage (ϕ)	240 VAC / 24 VAC/DC		240 VAC
Supply Variation	- 20% to +10% (of ϕ)		- 20% to +10% (of ϕ)
Frequency	50/60 Hz		50 Hz
Power Consumption (Max.)	8 VA		8 VA
Timing Ranges	0.3s to 30h		3s to 120s
Pause Time	N A		60 ms
Reset Time	100 ms (Max.)		150 ms (Max.)
Setting Accuracy	± 5% of Full scale		
Repeat Accuracy	± 1%		
Output	Relay Output	1 C/O	
	Contact Rating	5A @ 240 VAC / 28 VDC (Resistive)	Star - 1 'NO', Delta - 1 'NO'
	Electrical Life	1X10 ⁵	
	Mechanical Life	5X10 ⁶	
Utilization Category	AC - 15	Rated Voltage (Ue): 120/240 V, Rated Current (Ie): 3.0/1.5 A	
	DC - 13	Rated Voltage (Ue): 24/125/250 V, Rated Current (Ie): 2.0/0.22/0.1 A	
Operating Temperature	-10°C to +55°C		
Storage Temperature	-20°C to +70°C		
Humidity (Non Condensing)	95% (Rh)		
LED Indication	Green LED → Power ON, Red LED → Relay ON		Red LED 1 → 'Y' ON, Red LED 2 → 'Δ' ON
Enclosure	Flame Retardant UL94-V0		
Dimension (W x H x D) (in mm)	17.5 X 90 X 58.5		
Weight (unpacked) Approx.	65 g		60 g
Mounting	Base / DIN Rail		
Certification			
Degree of Protection	IP 20 for Terminals, IP 40 for Enclosure		
EMI / EMC			
Harmonic Current Emissions	IEC 61000-3-2	Ed. 3.2 (2009-04) Class A	
ESD	IEC 61000-4-2	Ed. 2.0 (2008-12) Level II	
Radiated Susceptibility	IEC 61000-4-3	Ed. 3.2 (2010-04) Level III	
Electrical Fast Transients	IEC 61000-4-4	Ed. 3.0 (2012-04) Level IV	
Surges	IEC 61000-4-5	Ed. 2.0 (2005-11) Level IV	
Conducted Susceptibility	IEC 61000-4-6	Ed. 3.0 (2008-10) Level III	
Voltage Dips & Interruptions (AC)	IEC 61000-4-11	Ed. 2.0 (2004-03) All 7 Levels	
Voltage Dips & Interruptions (DC)	IEC 61000-4-29	Ed. 1.0 (2000-08) All 5 Levels	
Conducted Emission	CISPR 14-1	Ed. 5.2 (20011-11) Class A	
Radiated Emission	CISPR 14-1	Ed. 5.2 (20011-11) Class A	
Environmental			
Cold Heat	IEC 60068-2-1	Ed. 6.0 (2007-03)	
Dry Heat	IEC 60068-2-2	Ed. 5.0 (2007-07)	
Vibration	IEC 60068-2-6	Ed. 7.0 (2007-12) 5g	
Repetitive Shock	IEC 60068-2-27	Ed. 4.0 (2008-02) 40g, 6ms	
Non-Repetitive Shock	IEC 60068-2-27	Ed. 4.0 (2008-02) 30g, 15ms	

ORDERING INFORMATION

Cat. No.	Description
11ODT4	110 VA / 24 VAC/DC, ON Delay Timer, 1 C/O
12ODT4	240 VAC / 24 VAC/DC, ON Delay Timer, 1 C/O
15ODT4	12 VDC, ON Delay Timer, 1 C/O
11SDT0	110 VAC, Star Delta Timer, 1 NO (Star) + 1 NO (Delta)
12SDT0	240 VAC, Star Delta Timer, 1 NO (Star) + 1 NO (Delta)
14SDT1S	240-415V AC, Star Delta Timer, 1C/O (Star) + 1C/O (Delta), 3-30 Sec.



Cat. No.	15BDT4	
Parameters		
Timer Description	One Shot Timer	
Mode	One Shot	
Functional Diagram		
Supply Voltage (φ)	12 VDC	
Supply Variation	- 20% to +10% (of φ)	
Frequency	N A	
Power Consumption (Max.)	0.5 VA	
Timing Ranges	0.3s to 30h	
Reset Time	100 ms (Max.)	
Setting Accuracy	± 5% of Full scale	
Repeat Accuracy	± 1%	
Output	Relay Output	1 C/O
	Contact Rating	5A (resistive) @ 240 VAC / 28 VDC
	Electrical Life	1X10 ⁵
	Mechanical Life	5X10 ⁶
Utilization Category	AC - 15	Rated Voltage (Ue): 120/240 V, Rated Current (Ie): 3.0/1.5 A
	DC - 13	Rated Voltage (Ue): 24/125/250 V, Rated Current (Ie): 2.0/0.22/0.1 A
Operating Temperature	-10°C to +55°C	
Storage Temperature	-20°C to +70°C	
Humidity (Non Condensing)	95% (Rh)	
LED Indication	Green LED → Power ON, Red LED → Relay ON	
Enclosure	Flame Retardant UL94-V0	
Dimension (W x H x D) (in mm)	17.5 X 90 X 58.5	
Weight (unpacked)	75 g	
Mounting	Base / DIN Rail	
Certification		
Degree of Protection	IP 20 for Terminals, IP 40 for Enclosure	
EMI / EMC		
Harmonic Current Emissions	IEC 61000-3-2	Ed. 3.2 (2009-04) Class A
ESD	IEC 61000-4-2	Ed. 2.0 (2008-12) Level II
Radiated Susceptibility	IEC 61000-4-3	Ed. 3.2 (2010-04) Level III
Electrical Fast Transients	IEC 61000-4-4	Ed. 3.0 (2012-04) Level IV
Surges	IEC 61000-4-5	Ed. 2.0 (2005-11) Level IV
Conducted Susceptibility	IEC 61000-4-6	Ed. 3.0 (2008-10) Level III
Voltage Dips & Interruptions (AC)	IEC 61000-4-11	Ed. 2.0 (2004-03) All 7 Levels
Voltage Dips & Interruptions (DC)	IEC 61000-4-29	Ed. 1.0 (2000-08) All 5 Levels
Conducted Emission	CISPR 14-1	Ed. 5.2 (2011-11) Class A
Radiated Emission	CISPR 14-1	Ed. 5.2 (2011-11) Class A
Environmental		
Cold Heat	IEC 60068-2-1	Ed. 6.0 (2007-03)
Dry Heat	IEC 60068-2-2	Ed. 5.0 (2007-07)
Vibration	IEC 60068-2-6	Ed. 7.0 (2007-12) 5g
Repetitive Shock	IEC 60068-2-27	Ed. 4.0 (2008-02) 40g, 6ms
Non-Repetitive Shock	IEC 60068-2-27	Ed. 4.0 (2008-02) 30g, 15ms

ORDERING INFORMATION

Cat. No.	Description
11BDT4	110 VAC / 24 VAC/DC, One Shot Timer, 1 C/O
12BDT4	240 VAC / 24 VAC/DC, One Shot Timer, 1 C/O
15BDT4	12 VDC, One Shot Timer, 1 C/O

Electronic Timer - Series Micon® 175

- Multi Function: 10 Different (Non Signal & Signal based) Modes
- Wide Voltage range for both AC & DC
- Wide Time range: 0.1s - 100h
- LED Indications for Power and Relay status
- Independent settings for both ON Time & OFF Time
- Low Power Consumption



Cat. No.		1CJDT0	1CMDT0
Parameters			
Timer Description		Asymmetric Timer	Multi Function Timer
Modes		1) Asymmetric ON-OFF, 2) Asymmetric OFF-ON	1) Signal ON Delay 2) Cyclic ON/OFF 3) Cyclic OFF/ON 4) Signal OFF Delay 5) Signal OFF/ON 6) Accumulative Delay on Signal 7) Impulse ON/OFF 8) Leading Edge Impulse 9) Trailing Edge Impulse 10) Leading Edge Bi-stable
Derived Modes		N A	ON Delay, Interval
Supply Voltage (ϕ)		12 - 240 VAC/DC	
Supply Variation		-15% to +10% (of ϕ)	
Frequency		50/60 Hz	
Power Consumption (Max.)		2 VA	
Timing Range		0.1s to 100h	
Reset Time		200 ms (Max)	
Setting Accuracy		± 5% of Full scale	
Repeat Accuracy		± 1%	
Output	Relay Output	1 C/O	1 C/O
	Contact Rating	8A @ 240 VAC / 5A @ 24 VDC (Resistive)	8A @ 240 VAC / 5A @ 24 VDC (Resistive)
	Electrical Life	1X10 ⁵	
	Mechanical Life	5X10 ⁶	
Utilization Category	AC - 15	Rated Voltage (Ue): 120/240 V, Rated Current (Ie): 3.0/1.5 A	
	DC - 13	Rated Voltage (Ue): 24/125/250 V, Rated Current (Ie): 2.0/0.22/0.1 A	
Operating Temperature		-10°C to +60°C	
Storage Temperature		-15°C to +70°C	
LED Indication		Green LED → Power ON, Amber LED → Relay ON	Green LED → Power ON, Yellow LED → Relay ON
Enclosure		Flame Retardant UL94-V0	
Dimension (W x H x D) (in mm)		18 X 85 X 65	
Weight (unpacked)		70 g	
Mounting		Base / DIN Rail	
Certification		 	
Degree of Protection		IP 20 for Terminals, IP 40 for Enclosure	
EMI / EMC			
Harmonic Current Emissions		IEC 61000-3-2	Ed. 3.2 (2009-04) Class A
ESD		IEC 61000-4-2	Ed. 2.0 (2008-12) Level II
Radiated Susceptibility		IEC 61000-4-3	Ed. 3.2 (2010-04) Level III
Electrical Fast Transients		IEC 61000-4-4	Ed. 3.0 (2012-04) Level IV
Surges		IEC 61000-4-5	Ed. 2.0 (2005-11) Level IV
Conducted Susceptibility		IEC 61000-4-6	Ed. 3.0 (2008-10) Level III
Voltage Dips & Interruptions (AC)		IEC 61000-4-11	Ed. 2.0 (2004-03) All 7 Levels
Voltage Dips & Interruptions (DC)		IEC 61000-4-29	Ed. 1.0 (2000-08) All 5 Levels
Conducted Emission		CISPR 14-1	Ed. 5.2 (20011-11) Class B
Radiated Emission		CISPR 14-1	Ed. 5.2 (20011-11) Class A
Environmental			
Cold Heat		IEC 60068-2-1	Ed. 6.0 (2007-03)
Dry Heat		IEC 60068-2-2	Ed. 5.0 (2007-07)
Vibration		IEC 60068-2-6	Ed. 7.0 (2007-12) 5g
Repetitive Shock		IEC 60068-2-27	Ed. 4.0 (2008-02) 40g, 6ms
Non-Repetitive Shock		IEC 60068-2-27	Ed. 4.0 (2008-02) 30g, 15ms

ORDERING INFORMATION

Cat. No.	Description
1CMDT0	12 - 240 VAC/DC, Multi Function Timer (10 Modes), 1 C/O (RAL 7016 Casing)
1CJDT0	12 - 240 VAC/DC, Asymmetric Timer, 1 C/O (RAL 7016 Casing)
1CMDTB	12 - 240 VAC/DC, Multi Function Timer (10 Modes), 1 C/O (RAL 7035 Casing)
1CJDTB	12 - 240 VAC/DC, Asymmetric Timer, 1 C/O (RAL 7035 Casing)



FUNCTIONAL DIAGRAMS FOR 1CMDT0

⏻: Supply Voltage, S: Input Signal, R: Relay Output
T: Preset Time, TON: Preset ON Time, TOFF: Preset OFF Time

SIGNAL ON DELAY [stn]

On application of input signal, the preset delay time period starts. On completion of the preset time, the output is switched ON and remains ON till the input signal is present.

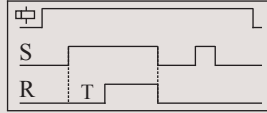

ACCUMULATIVE DELAY On SIGNAL [san]

On application of supply voltage, the preset delay time period starts. If input signal is applied during this period, the preset time stops and resumes only when the input signal is removed. On completion of the preset time, the output is switched ON.

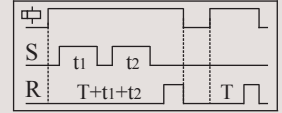

CYCLIC ON/OFF [cnf]

On application of supply voltage, the output is initially switched ON for the preset time duration (T) after which it is switched OFF for the same time duration (T). This cycle continues till the power supply is present.



IMPULSE ON/OFF [inf]

On application or removal of input signal to the timer, the output is immediately switched ON for the preset time duration (T). If the state of the input signal is changed during the preset time, the output does not change state only the time is reset.

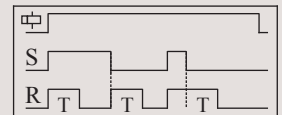

CYCLIC OFF/ON [cfn]

On application of supply voltage, the output is initially switched OFF for the preset time duration (T) after which it is switched ON for the same time duration (T). This cycle continues till the power supply is present.



LEADING EDGE IMPULSE [il]

When input signal is applied to the timer the output is immediately switched ON. The output remains ON for the preset time duration (T) after which it is switched OFF. If the input signal is removed during the preset time, the output is immediately switched OFF.

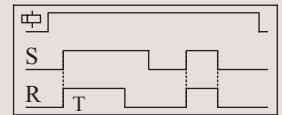

SIGNAL OFF DELAY [sf]

On application of input signal to the timer, the output is immediately switched ON. When the input signal is switched OFF, the preset time delay period starts. On completion of the time period the output is switched OFF.

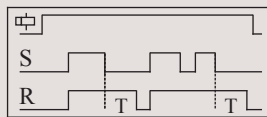

TRAILING EDGE IMPULSE [it]

When the input signal to the timer is removed, the output is immediately switched ON for the preset time duration (T) after which it is switched OFF. If the input signal is applied during the preset time, the output is immediately switched OFF.

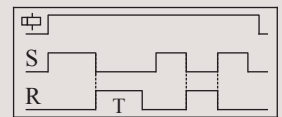

SIGNAL OFF/ON [sfn]

On application of input signal to the timer, the preset delay time period (T) starts. On completion of the time preset time, the output is switched ON. When the input signal is switched OFF, again the preset time delay period (T) starts. On completion of the time period the output is switched OFF.

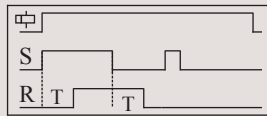

LEADING EDGE BISTABLE [sbi]

On application of input signal to the timer, the output is switched ON and remains ON even after the input signal is removed. On subsequent application of input signal, the output keeps on changing its state.

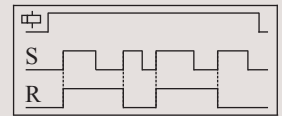

DERIVED MODES

Select mode, 'Signal ON Delay' and short the connection between A1 - B1 before power ON. Select mode, 'Accumulative Delay ON Signal' and keep the connection between A1 - B1 open.

ON DELAY

When supply power is applied to the timer, the preset delay time period starts. On completion of the preset time, the output is switched ON and remains ON till the input supply is present.

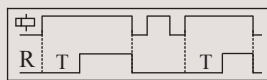

FUNCTIONAL DIAGRAMS FOR 1CJDT0

ASYMMETRIC ON-OFF

On application of supply voltage, the output is initially switched ON for the preset 'ON' time duration (T) after which it is switched OFF for the preset 'OFF' time duration (T). This cycle repeats and continues till the supply is present. The ON time & OFF time are set independently.



Select mode, "Leading Edge Impulse" and short the connection between A1 & B1.

INTERVAL

When supply power is applied to the timer, the output is instantly switched ON. On completion of the preset time, the output is switched OFF.

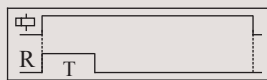

ASYMMETRIC OFF-ON

On application of supply voltage, the output is initially switched OFF for the preset 'OFF' time duration (T) after which it is switched ON for the preset 'ON' time duration (T). This cycle repeats and continues till the supply is present. The ON time & OFF time are set independently.

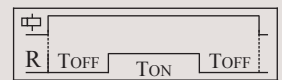

MOUNTING DIMENSIONS (mm)

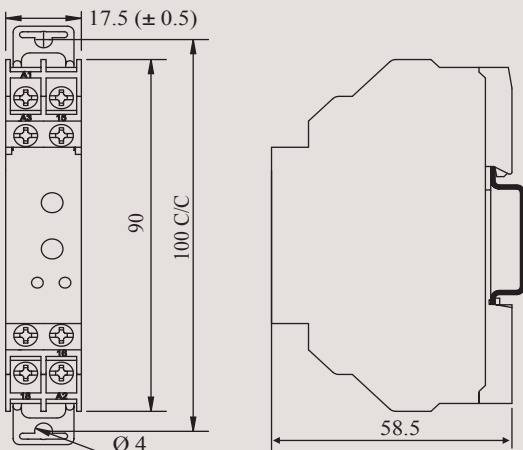
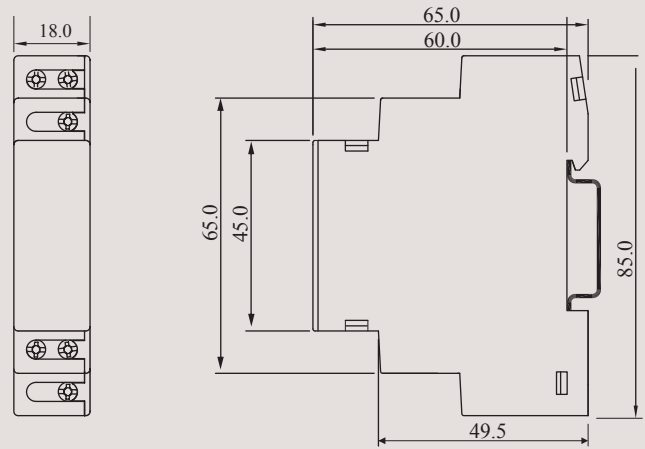
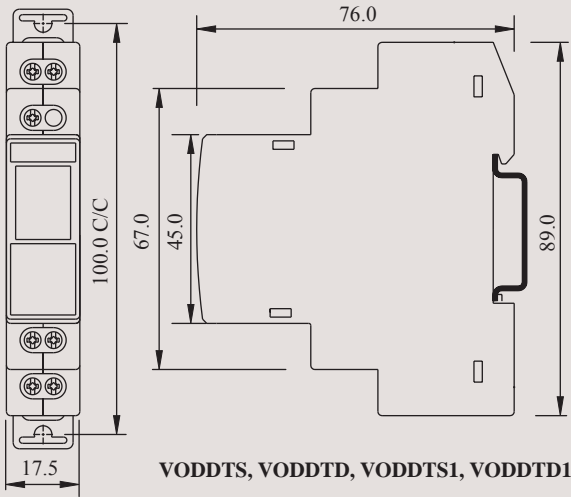

CONNECTION DIAGRAM

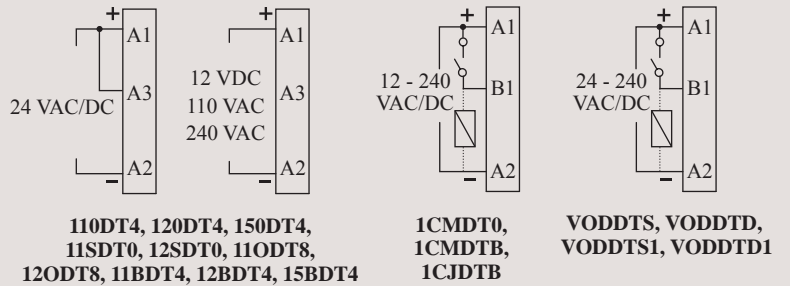

110DT4, 120DT4, 150DT4, 11SDT0, 12SDT0, 11ODT8, 12ODT8, 11BDT4, 12BDT4, 15BDT4

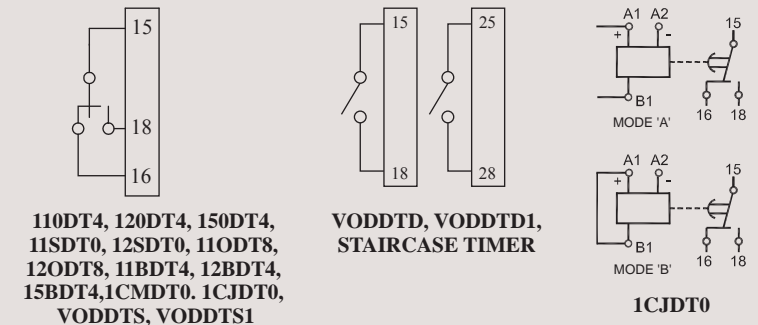

TERMINAL TORQUE & CAPACITY

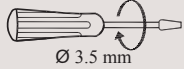
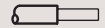
 Ø 3.5 mm	Torque - 0.40 N.m (3.5 Lb.in) Terminal screw - M2.5
	Solid Wire - 1 X 0.3...2.5 mm ²
AWG	1 X 22 to 14

VODDTS, VODDTD, VODDTS1, VODDTD1

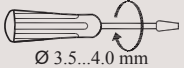
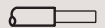
 Ø 3.5...4.0 mm	Torque - 0.6 N.m (6 Lb.in) Terminal screw - M3
	Solid Wire - 1 X 1...4 mm ²
AWG	1 X 18 to 10

1CMDT0, 1CJDT0, STAIRCASE TIMER

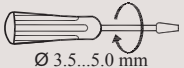
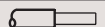
 Ø 3.5...5.0 mm	Torque - 1.1 N.m (10 Lb.in) Terminal screw - M3.5
	Solid Wire - 2 X 0.2...2.5 mm ²
AWG	1 X 24 to 10

110DT4, 120DT4, 150DT4, 11SDT0, 12SDT0, 11ODT8, 12ODT8, 11BDT4, 12BDT4, 15BDT4

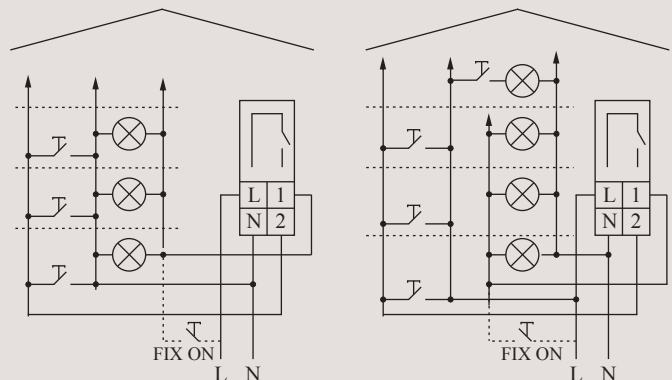

3 Wire Configuration

4 Wire Configuration

STAIRCASE TIMER

Electronic Timer - Series Micon® 225

Signal Based Multi - Function

- Multi-function with Signal Start and Supply Start.
- 16 Timing Functions selected by DIP switch.
- Two independent relay outputs with either both relays timed or one timed and one instantaneous.
- Wide Input Signal & Supply range - 24-240V AC/DC.
- Wide Timing Range - 0.1 s to 120 days.
- High timing Accuracy.
- LED indicators for Power Supply & Relay Status.
- 22.5mm DIN Mount Housing.



Cat. No. 2A8DT6

Parameters		2A8DT6
Timer Description		Multi-function with Signal Start and Supply Start
Supply Voltage (ϕ)		24-240 VAC / DC
Supply Variation		- 20% to +10% (of ϕ)
Frequency		50/60 Hz
Power Consumption (Max.)		3 VA
Initiate Time		100 ms (Max.)
Reset Time		200 ms (Max.)
Signal Voltage	Low Range (B1L-A2)	24-60V AC/DC
	High Range (B1H-A2)	85-265V AC, 100-265V DC
Signal Sensing Time		For AC Signals: 50 ms Max. For DC Signals: 20 ms Max.
Signal stabilization Delay		100 ms (Applicable at Power ON Only)
Setting Accuracy		± 5% of Full scale
Repeat Accuracy		± 1%
Output	Relay Output	1 C/O (Delayed) & 1 C/O (Configurable as either Delayed or Instant)
	Contact Rating	5A @ 240 VAC / 28 VDC (Resistive)
	Contact Material	AgNi
	Electrical Life	1x10 ⁵
	Mechanical Life	1x10 ⁷
Set Time (Ts)		0.1 seconds to 120 Days
Functions		Refer page no. 23 and 24
LED Indication on front panel		Green LED ON: Power ON, Amber LED ON :Relay ON for Delayed contact
Mounting		Base / DIN Rail
Max. Operating Altitude		2000 m
Housing		Flame retardant (UL 94-V0)
Operating Temperature		-10°C to +60°C
Storage Temperature		-20°C to +70°C
Humidity (Non Condensing)		95% (Rh)
LED Indication		Green LED → Power ON, Red LED → Relay ON
Enclosure		Flame Retardant UL94-V0
Dimension (W x H x D) (in mm)		22.5 X 83 X 100.5
Weight (unpacked)		130 g
Pollution Degree		II
Certification		
Degree of Protection		IP 20 for Terminals, IP 40 for Enclosure
EMI / EMC		
Harmonic Current Emissions	IEC 61000-3-2	Ed. 3.2 (2009-04) Class A
ESD	IEC 61000-4-2	Ed. 2.0 (2008-12) Level II
Radiated Susceptibility	IEC 61000-4-3	Ed. 3.2 (2010-04) Level III
Electrical Fast Transients	IEC 61000-4-4	Ed. 3.0 (2012-04) Level IV
Surges	IEC 61000-4-5	Ed. 2.0 (2005-11) Level IV
Conducted Susceptibility	IEC 61000-4-6	Ed. 3.0 (2008-10) Level III
Voltage Dips & Interruptions (AC)	IEC 61000-4-11	Ed. 2.0 (2004-03) All 7 Levels
Conducted Emission	CISPR 14-1	Ed. 5.2 (20011-11) Class B
Radiated Emission	CISPR 14-1	Ed. 5.2 (20011-11) Class A
Safety:		
Test Voltage between I/P and O/P	IEC 60947-5-1	Ed.3.0 (2003-11) 2 kv
Test Voltage between all terminals & enclosure	IEC 60947-5-1	Ed.3.0 (2003-11) 4 kv
Impulse Voltage between I/P and O/P	IEC 60947-5-1	Ed.3.0 (2003-11) Level IV
Single Fault	IEC 61010-1	Ed.3.0 (2010-06)
Insulation Resistance	UL 508	Ed.17 (1999-01) > 50 M
Leakage Current	UL 508	Ed.17 (1999-01) < 3.5 mA
Product Reference Standard	IEC 61812-1	Ed.2.0 (2011-05)
Environmental		
Cold Heat	IEC 60068-2-1	Ed. 6.0 (2007-03)
Dry Heat	IEC 60068-2-2	Ed. 5.0 (2007-07)
Vibration	IEC 60068-2-6	Ed. 7.0 (2007-12) 5g
Repetitive Shock	IEC 60068-2-27	Ed. 4.0 (2008-02) 40g, 6ms
Non-Repetitive Shock	IEC 60068-2-27	Ed. 4.0 (2008-02) 30g, 15ms

ORDERING INFORMATION

Cat. No.	Description
2A8DT6	24-240 VAC / DC, Signal Based Multi - Function, 1 C/O + 1 C/O

Electronic Timer - Series Micon® 225

Signal Based Multi - Function



FUNCTIONAL DIAGRAMS

\square : Supply Voltage, S: Input Signal, R: Relay Output, R(I): Instant Relay, R(D): Delayed Relay
 T: Preset Time, TON: Preset ON Time, TOFF: Preset OFF Time, T-a: Timing Break Before completion

ON DELAY (Non Signal Based)

When supply is applied, timing starts and after the preset time duration 'T', output switches ON and remains ON till the supply is present.

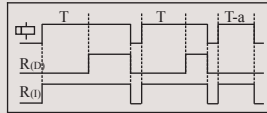

CYCLIC ON/OFF

When the supply applied and signal is closed, output switches ON for the preset time duration 'T' and then switches OFF for preset time duration 'T'. This cycle repeats while the supply is present. Changing the state of signal during 'T' does not affect the output.

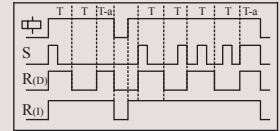

SIGNAL ON DELAY TYPE 1

When the input supply & signal are applied, timing starts and after preset time duration 'T' output switches ON & remains ON till the supply is present. Changing the state of signal during 'T' does not affect the output.

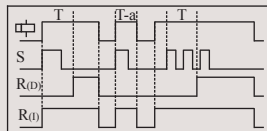

SIGNAL ON/ OFF Delay

Signal ON/OFF Delay: When the supply is applied and signal is closed, outputs switches ON after preset time 'T'. During the timing 'T' if signal is opened, the output switches ON immediately and OFF delay starts. Once this time period has elapsed the output switches OFF. During this OFF delay if signal is closed, the output switches OFF immediately and ON Delay restarts.

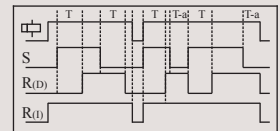

SIGNAL ON DELAY

Time commences as supply and signal is present. When input signal is opened, the timing resets. The output is switched ON at the end of the preset time duration 'T'. When output is ON if signal is opened then the output switches OFF.

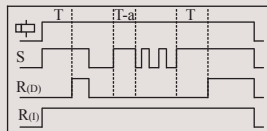

IMPULSE ON/OFF

When supply is applied and if signal closed or opened, output switches ON for Preset time duration 'T'. During time period 'T', changing state of input signal does not affect the output but resets the timing.

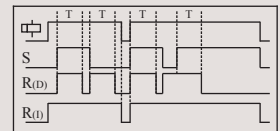

INVERTED SIGNAL ON DELAY

When supply is applied and signal is opened, preset time duration 'T' starts. On completion of the 'T', output switches ON. If the signal is closed during timing 'T', timing resets.

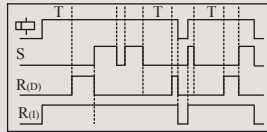

ACCUMULATIVE DELAY ON SIGNAL

Accumulative Delay ON Signal: On application of the supply voltage, the preset timing commences. Whenever signal is closed, timing pauses & resumes back only when the input signal is opened. The output switches ON at the end of the preset time duration 'T'.

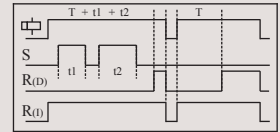

INTERVAL

When supply voltage is applied & signal is closed, output switches ON & timing function starts. If signal is opened and closed during the preset time, the timing restarts. After preset time 'T' has elapsed, the output switches OFF.

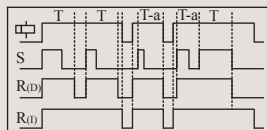

DELAYED IMPULSE

Delayed Impulse: When supply voltage is applied and signal is closed, output switches ON at the end of the preset time 'TOFF'. Then the preset ON time 'TON' starts irrespective of the signal state and remains ON till the completion of preset time duration 'TON'. If signal closed during the timing 'TOFF', the timing restarts but the output state remains unaffected. The signal change does not have any effect during the timing period 'TON'.

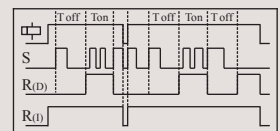

LEADING EDGE IMPULSE

When the supply applied and signal is closed, the output switches ON for preset time 'T'. After the completion of preset time 'T', the output switches OFF. If signal closed or opened during preset time duration 'T', the output remains unaffected.

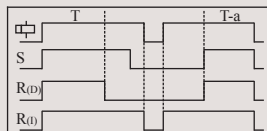

ONE SHOT

One Shot: When the supply voltage is applied and signal is closed, timing starts and after the preset time duration 'T', output switches ON for One sec. only.

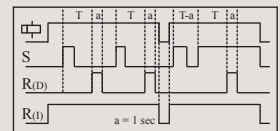

TRAILING EDGE IMPULSE

When supply voltage is applied and signal is opened, output switches ON for the preset time duration 'T'. After completion of preset time 'T', output switches OFF. If the signal is closed during preset timing 'T', output switches OFF & timing stops.

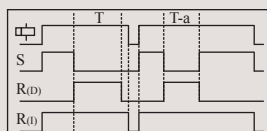

STEP MODE

Step Mode: When the supply voltage is applied and signal closed, output switches ON for preset time duration 'T', removal of the input signal during this time duration 'T' does not affect the output state. But if the signal is closed during time duration 'T', output switches OFF.

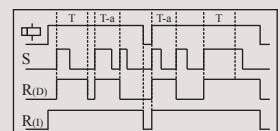

CYCLIC OFF/ON

When the supply applied and signal is closed, output switches OFF for the preset time duration 'T' and then switches ON for preset time duration 'T'. This cycle repeats while the supply is present. Changing the state of signal during 'T' does not affect the output.

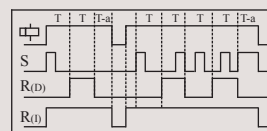

SIGNAL OFF DELAY

Signal OFF Delay: When the supply is applied and signal is closed, output is switches ON. When signal is opened, the preset timing commences and output is switches OFF at the end of time duration 'T'. If signal is closed during timing period, then timing stops and restarts when signal.

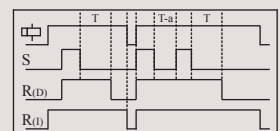

Electronic Timer - Series Micon® 225 Signal Based Multi - Function



Selection of Function: Operating Mode & timing can be selected by using DIP switches

Function		Function	
1 2 3 4 [][][][]	On Delay (Non Signal)	1 2 3 4 [][][][]	Signal OFF Delay
[][][][]	Signal On Delay Type 1	[][][][]	Step Mode
[][][][]	Signal On Delay	[][][][]	One Shot
[][][][]	Inverted Signal On Delay	[][][][]	Delayed Impulse
[][][][]	Interval	[][][][]	Accumulative Delay On Signal
[][][][]	Leading Edge Impulse	[][][][]	Impulse ON / OFF
[][][][]	Trailing Edge Impulse	[][][][]	Signal ON / OFF Delay
[][][][]	Cyclic OFF / ON	[][][][]	Cyclic ON / OFF
11 + 1D or 2D Selection		Timing Multiplier Selection	
5 []	11 + 1D Operation	6 []	Timing = 'T' X 't' X 1
[]	2 Delayed Operation	[]	Timing = 'T' X 't' X 12

MOUNTING DIMENSION (mm)

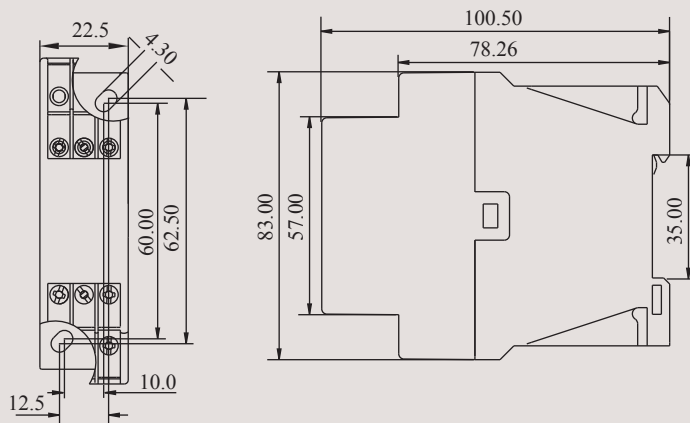

CONNECTION DIAGRAM

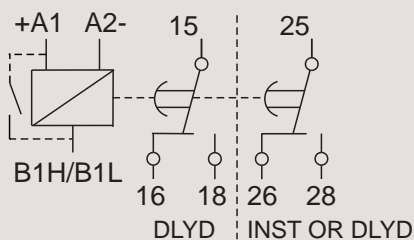

TERMINAL TORQUE & TERMINAL CAPACITY

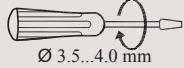
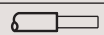
 Ø 3.5...4.0 mm	Torque - 0.6 N.m (6 Lb.in) Terminal screw - M3
	1 X 1...4 mm ² Solid / Stranded Wire
AWG	1 X 16 to 12

Electronic Timer - Series Micon® 225

- Compact 22.5mm Wide
- Wide Time Range: 0.1s to 10h
- Wide Voltage range for both AC & DC

- Flush knobs for better security
- LED Indications for Power and Relay status
- Excellent Noise Immunity to the latest IEC standards

Multi Function Timer

- Multi Function Timer with 5 different modes
- 2 C/O Configuration

Multi Function Timer with 1 Instant & 1 Delayed C/O

- Multi Function Timer with 6 different modes
- 2 C/O Configuration (1 Instant + 1 Delayed)



Cat. No.		2A5DT5	2B6DT6
Parameters			
Timer Description		Multi Function Timer	Multi Function Timer
Modes		ON Delay, Interval, Cyclic ON-OFF, Cyclic OFF-ON, One Shot	ON Delay, Interval, Cyclic ON-OFF, Cyclic OFF-ON, One Shot, ON Delay with 1 Instant & 1 Delayed
Functional Diagram			
Supply Voltage (φ)		24 - 240 VAC/DC	240 - 415 VAC
Supply Variation		- 20% to +10% (of φ)	
Frequency		50/60 Hz	
Power Consumption (Max.)		4 VA	7 VA
Timing Range		0.1s to 10h	
Reset Time		200 ms (Max.)	
Setting Accuracy		± 5% of Full scale	
Repeat Accuracy		± 1%	
Output	Relay Output	2 C/O	2 C/O, 1 Instant + 1 Delayed (for 6th mode)
	Contact Rating	5A @ 240 VAC / 28 VDC (Resistive)	
	Electrical Life	1x10 ⁵	
	Mechanical Life	1x10 ⁷	
Utilization Category	AC - 15	Rated Voltage (Ue): 120/240 V, Rated Current (Ie): 3.0/1.5 A	
	DC - 13	Rated Voltage (Ue): 24/125/250 V, Rated Current (Ie): 2.0/0.22/0.1 A	
Operating Temperature		-15°C to +60°C	
Storage Temperature		-20°C to +80°C	
Humidity (Non Condensing)		95% (Rh)	
LED Indication		Green LED → Power ON, Red LED → Relay ON	
Enclosure		Flame Retardant UL94V0	
Dimension (W x H x D) (in mm)		22.5 X 75 X 100.5	
Weight (unpacked)		130 g	
Mounting		Base / DIN Rail	
Certification			
Degree of Protection		IP 20 for Terminals, IP 40 for Enclosure	
EMI / EMC			
Harmonic Current Emissions		IEC 61000-3-2	Ed. 3.2 (2009-04) Class A
ESD		IEC 61000-4-2	Ed. 2.0 (2008-12) Level II
Radiated Susceptibility		IEC 61000-4-3	Ed. 3.2 (2010-04) Level III
Electrical Fast Transients		IEC 61000-4-4	Ed. 3.0 (2012-04) Level IV
Surges		IEC 61000-4-5	Ed. 2.0 (2005-11) Level IV
Conducted Susceptibility		IEC 61000-4-6	Ed. 3.0 (2008-10) Level III
Voltage Dips & Interruptions (AC)		IEC 61000-4-11	Ed. 2.0 (2004-03) All 7 Levels
Voltage Dips & Interruptions (DC)		IEC 61000-4-29	Ed. 1.0 (2000-08) All 5 Levels
Conducted Emission		CISPR 14-1	Ed. 5.2 (20011-11) Class A
Radiated Emission		CISPR 14-1	Ed. 5.2 (20011-11) Class A
Environmental			
Cold Heat		IEC 60068-2-1	Ed. 6.0 (2007-03)
Dry Heat		IEC 60068-2-2	Ed. 5.0 (2007-07)
Vibration		IEC 60068-2-6	Ed. 7.0 (2007-12) 5g
Repetitive Shock		IEC 60068-2-27	Ed. 4.0 (2008-02) 40g, 6ms
Non-Repetitive Shock		IEC 60068-2-27	Ed. 4.0 (2008-02) 30g, 15ms

* Available only with Cat. No. 2A6DT6 & 2B6DT6

ORDERING INFORMATION

Cat. No.	Description
2A5DT5	24 - 240 VAC/DC, Multi Function Timer (5 Modes), 2 C/O
2B5DT5	240 - 415 VAC, Multi Function Timer (5 Modes), 2 C/O
2A6DT6	24 - 240 VAC/DC, Multi Function Timer (6 Modes), 2 C/O (1 Instant + 1 Delayed for 6th Mode)
2B6DT6	240 - 415 VAC, Multi Function Timer (6 Modes), 2 C/O (1 Instant + 1 Delayed for 6th Mode)
2AODT5	24 - 240 VAC/DC, ON Delay, 2 C/O

Electronic Timer - Series Micon® 225

- Signal based Multi-function with Relay / Solid State Output
- Asymmetric Timer with Solid State Output



Cat. No.		2ANDT0	20NDTT
Parameters			
Description Signal Based Multi Function			
Modes Signal ON Delay, Accumulative ON Delay, Signal OFF Delay, Signal OFF/ON Delay, Leading Edge Impulse			
Derived Modes ON Delay, Interval			
Functional Diagram			
Supply Voltage (φ)		24 - 240 VAC/DC	110 - 240 VAC
Supply Variation		- 20% to +10% (of φ)	
Frequency		50/60 Hz	
Power Consumption (Max.)		4 VA	
Timing Ranges		0.1s to 10h	
Reset Time		200 ms (Max.)	
Setting Accuracy		± 5% of Full scale	
Repeat Accuracy		± 1%	
Output	Relay Output	1 C/O (SPDT)	N A
	Contact Rating	5A @ 240 VAC / 28 VDC (Resistive)	N A
	Electrical Life	1x10 ⁵	N A
	Mechanical Life	1x10 ⁷	N A
Solid State Output	Type & Form	N A	Optical Isolation, SPST
	Rated Current	N A	1A (AC)
	Max. Admissible Current	N A	20A (10 ms)
	Vol. Breaking Capacity	N A	110 to 240 VAC
	Max. Drop @ Terminals	N A	≤ 8V
	Electrical Life	N A	1x10 ⁶
Utilization Category	AC - 15	Rated Voltage (Ue): 120/240 V, Rated Current (Ie): 3.0/1.5 A	
	DC - 13	Rated Voltage (Ue): 24/125/250 V, Rated Current (Ie): 2.0/0.22/0.1 A	
Operating Temperature		-15° C to +60° C	
Storage Temperature		-20° C to +80° C	
Humidity (Non Condensing)		95% (Rh)	
LED Indication		Green LED → Power ON Red LED → Relay ON	
Enclosure		Flame Retardant UL94-V0	
Dimension (W x H x D) (in mm)		22.5 X 75 X 100.5	
Weight (unpacked)		130 g	
Mounting		Base / DIN Rail	
Certification			
Degree of Protection		IP 20 for Terminals, IP 40 for Enclosure	
EMI / EMC			
Harmonic Current Emissions		IEC 61000-3-2	Ed. 3.2 (2009-04) Class A
ESD		IEC 61000-4-2	Ed. 2.0 (2008-12) Level II
Radiated Susceptibility		IEC 61000-4-3	Ed. 3.2 (2010-04) Level III
Electrical Fast Transients		IEC 61000-4-4	Ed. 3.0 (2012-04) Level IV
Surges		IEC 61000-4-5	Ed. 2.0 (2005-11) Level IV
Conducted Susceptibility		IEC 61000-4-6	Ed. 3.0 (2008-10) Level III
Voltage Dips & Interruptions (AC)		IEC 61000-4-11	Ed. 2.0 (2004-03) All 7 Levels
Voltage Dips & Interruptions (DC)		IEC 61000-4-29	Ed. 1.0 (2000-08) All 5 Levels
Conducted Emission		CISPR 14-1	Ed. 5.2 (2011-11) Class A
Radiated Emission		CISPR 14-1	Ed. 5.2 (2011-11) Class A
Environmental			
Cold Heat		IEC 60068-2-1	Ed. 6.0 (2007-03)
Dry Heat		IEC 60068-2-2	Ed. 5.0 (2007-07)
Vibration		IEC 60068-2-6	Ed. 7.0 (2007-12) 5g
Repetitive Shock		IEC 60068-2-27	Ed. 4.0 (2008-02) 40g, 6ms
Non-Repetitive Shock		IEC 60068-2-27	Ed. 4.0 (2008-02) 30g, 15ms

ORDERING INFORMATION

Cat. No.	Description
2ANDT0	24 - 240 VAC/DC, Signal Based Multi Function Timer, 1 C/O
20NDTT	110 - 240 VAC, Signal Based Multi Function Timer with Solid State Output
20JDTT	110 - 240 VAC, Asymmetric Timer with Solid State Output

Electronic Timer - Series Micon® 225

Asymmetric ON-OFF Timer

- Compact 22.5mm Wide
- Can be configured to Switch ON or Switch OFF first
- Independent settings for ON & OFF time
- Wide Time Range
- LED Indications for Power and Relay status

Star Delta Timer

- Settable Start Time
- Settable Pause Time
- Indications for Star & Delta
- Excellent Noise Immunity to the latest IEC standards



Cat. No.		2AADT5	2ASDT0
Parameters			
Timer Description		Asymmetric Timer	
Mode		Asymmetric ON-OFF (A), Asymmetric OFF-ON (B)	
Functional Diagram			
Supply Voltage (φ)		24 - 240 VAC/DC	
Supply Variation		- 20% to +10% (of φ)	
Frequency		50/60 Hz	
Power Consumption (Max.)		4 VA	
Timing Ranges		0.1s to 10h	
Pause Time (P)		N A	
Reset Time		200 ms (Max.)	
Setting Accuracy		± 5% of Full scale	
Repeat Accuracy		± 1%	
Output	Relay Output	2 C/O	
	Contact Rating	5A @ 240 VAC / 28 VDC (Resistive)	
	Electrical Life	1x10 ⁵	
	Mechanical Life	1x10 ⁷	
Utilization Category	AC - 15	Rated Voltage (Ue): 120/240 V, Rated Current (Ie): 3.0/1.5 A Rated Voltage (Ue): 24/125/250 V, Rated Current (Ie): 2.0/0.22/0.1 A	
	DC - 13		
Operating Temperature		-15°C to +60°C	
Storage Temperature		-20°C to +80°C	
Humidity (Non Condensing)		95% (Rh)	
LED Indication		Green LED → Power ON, Red LED → Relay ON	Red LED 1 → '∧' ON, Red LED 2 → 'Δ' ON
Enclosure		Flame Retardant UL94-V0	
Dimension (W x H x D) (in mm)		22.5 X 75 X 100.5	
Weight (unpacked)		130 g	
Mounting		Base / DIN Rail	
Certification			
Degree of Protection		IP 20 for Terminals, IP 40 for Enclosure	
EMI / EMC			
Harmonic Current Emissions		IEC 61000-3-2	Ed. 3.2 (2009-04) Class A
ESD		IEC 61000-4-2	Ed. 2.0 (2008-12) Level II
Radiated Susceptibility		IEC 61000-4-3	Ed. 3.2 (2010-04) Level III
Electrical Fast Transients		IEC 61000-4-4	Ed. 3.0 (2012-04) Level IV
Surges		IEC 61000-4-5	Ed. 2.0 (2005-11) Level IV
Conducted Susceptibility		IEC 61000-4-6	Ed. 3.0 (2008-10) Level III
Voltage Dips & Interruptions (AC)		IEC 61000-4-11	Ed. 2.0 (2004-03) All 7 Levels
Voltage Dips & Interruptions (DC)		IEC 61000-4-29	Ed. 1.0 (2000-08) All 5 Levels
Conducted Emission		CISPR 14-1	Ed. 5.2 (20011-11) Class A
Radiated Emission		CISPR 14-1	Ed. 5.2 (20011-11) Class A
Environmental			
Cold Heat		IEC 60068-2-1	Ed. 6.0 (2007-03)
Dry Heat		IEC 60068-2-2	Ed. 5.0 (2007-07)
Vibration		IEC 60068-2-6	Ed. 7.0 (2007-12) 5g
Repetitive Shock		IEC 60068-2-27	Ed. 4.0 (2008-02) 40g, 6ms
Non-Repetitive Shock		IEC 60068-2-27	Ed. 4.0 (2008-02) 30g, 15ms

ORDERING INFORMATION

Cat. No.	Description
2AADT5	24 - 240 VAC/DC, Asymmetric ON/OFF Timer, 2 C/O
2ASDT0*	24 - 240 VAC/DC, Star Delta Timer, 1 NO (Star) + 1 NO (Delta)
2ASDT1	24 - 240 VAC/DC, Star Delta Timer, 1 NO (Star) + 1 NO (Delta)
2BSDT0*	240 - 415 VAC, Star Delta Timer, 1 NO (Star) + 1 NO (Delta)
2BSDT1	240 - 415 VAC, Star Delta Timer, 1 NO (Star) + 1 NO (Delta)

*Note: Product with test voltage between input and output at 1.5 kV

Electronic Timer - Series Micon® 225

- True OFF Delay (Power OFF Delay) upto 600 seconds with 2 C/O.



Cat. No.		23GDT0	
Parameters			
Timer Description		True OFF Delay (Power OFF Delay) Timer	
Mode		True OFF Delay (Power OFF Delay)	
Functional Diagram			
Supply Voltage (ϕ)		24 - 240 VAC/DC	
Supply Variation		-10 to +20% (of ϕ)	
Frequency		50/60 Hz	
Power Consumption (Max.)		2.5 VA	
Energizing Time		1s (Minimum)	
Timing Range		0.6s to 600s	
Setting Accuracy		± 5% of Full scale	
Repeat Accuracy		± 1%	
Output	Relay Output	2 C/O	
	Contact Rating	5A @ 240 VAC / 28 VDC (Resistive)	
	Electrical Life	1x10 ⁵	
	Mechanical Life	1x10 ⁷	
Utilization Category	AC - 15	Rated Voltage (Ue): 120/240 V, Rated Current (Ie): 3.0/1.5 A	
	DC - 13	Rated Voltage (Ue): 24/125/250 V, Rated Current (Ie): 2.0/0.22/0.1 A	
Operating Temperature		-15°C to +60°C	
Storage Temperature		-20°C to +70°C	
Humidity (Non Condensing)		95% (Rh)	
LED Indication		Green LED → Power ON, Red LED → Relay ON	
Enclosure		Flame Retardant UL94-V0	
Dimension (W x H x D) (in mm)		22.5 X 75 X 100.5	
Weight (unpacked)		130 g	
Mounting		Base / DIN Rail	
Certification			
Degree of Protection		IP 20 for Terminals, IP 40 for Enclosure	
EMI / EMC			
Harmonic Current Emissions	IEC 61000-3-2	Ed. 3.2 (2009-04) Class A	
ESD	IEC 61000-4-2	Ed. 2.0 (2008-12) Level II	
Radiated Susceptibility	IEC 61000-4-3	Ed. 3.2 (2010-04) Level III	
Electrical Fast Transients	IEC 61000-4-4	Ed. 3.0 (2012-04) Level IV	
Surges	IEC 61000-4-5	Ed. 2.0 (2005-11) Level IV	
Conducted Susceptibility	IEC 61000-4-6	Ed. 3.0 (2008-10) Level III	
Voltage Dips & Interruptions (AC)	IEC 61000-4-11	Ed. 2.0 (2004-03) All 7 Levels	
Voltage Dips & Interruptions (DC)	IEC 61000-4-29	Ed. 1.0 (2000-08) All 5 Levels	
Conducted Emission	CISPR 14-1	Ed. 5.2 (20011-11) Class A	
Radiated Emission	CISPR 14-1	Ed. 5.2 (20011-11) Class A	
Environmental			
Cold Heat	IEC 60068-2-1	Ed. 6.0 (2007-03)	
Dry Heat	IEC 60068-2-2	Ed. 5.0 (2007-07)	
Vibration	IEC 60068-2-6	Ed. 7.0 (2007-12) 5g	
Repetitive Shock	IEC 60068-2-27	Ed. 4.0 (2008-02) 40g, 6ms	
Non-Repetitive Shock	IEC 60068-2-27	Ed. 4.0 (2008-02) 30g, 15ms	

ORDERING INFORMATION

Cat. No.	Description
23GDT0	24-240 VAC/DC, True OFF Delay (Power OFF Delay) Timer, 2 C/O

Electronic Timer - Series Micon® 225



MOUNTING DIMENSION (mm)

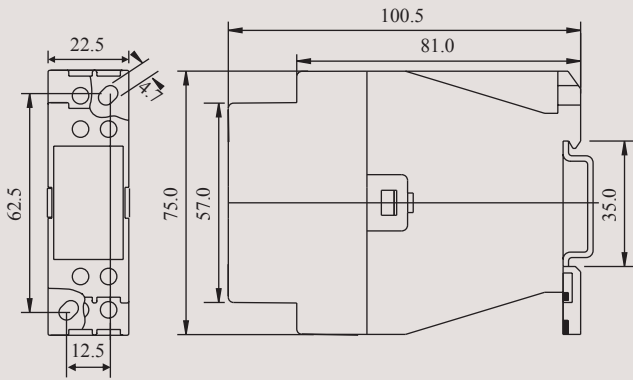

2A5DT5, 2B5DT5, 2AODT5, 2ASDT0, 2ASDT1,
2BSDT0, 2BSDT1, 2AJDT0, 2AJDT1, 2AADT5,
20JDTT, 20NDTT, 2ANDT0, 23GDT0, 2A6DT6, 2B6DT6

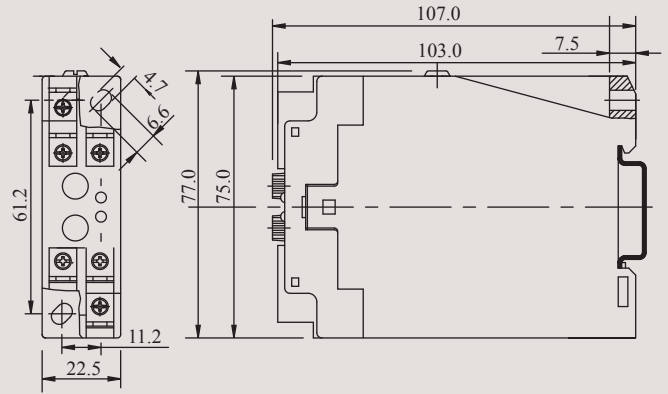

29ODT5, 25ADT5

CONNECTION DIAGRAM

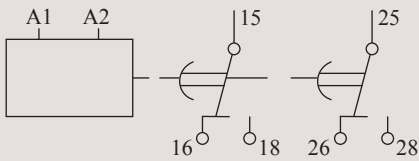

2A5DT5, 2B5DT5, 2AADT5, 23GDT0,
2AODT5, 273DT5, 29ODT5, 25ADT5

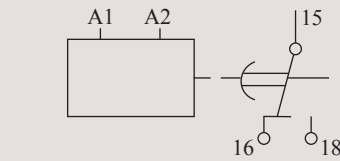

2AJDT0, 2AJDT1, 23UDT0, 27UDT0

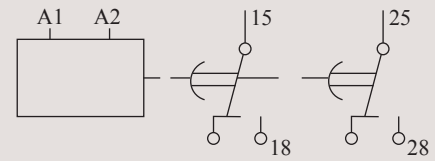

2ASDT0, 2BSDT0, 2ASDT1, 2BSDT1

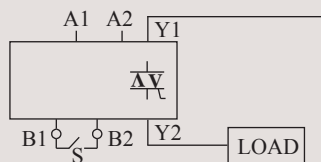

20JDTT, 20NDTT

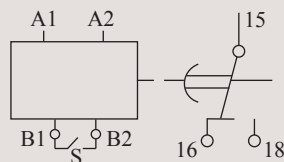

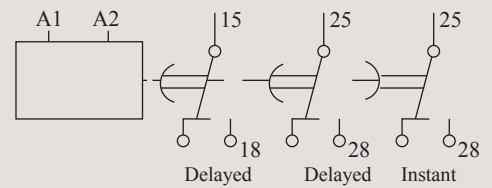

2ANDT0

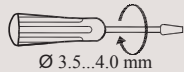

2A6DT6, 2B6DT6

TERMINAL TORQUE & TERMINAL CAPACITY

 Ø 3.5...4.0 mm	Torque - 0.6 N.m (6 Lb.in) Terminal screw - M3
	Solid Wire - 1 X 1...4 mm ²
AWG	1 X 18 to 10

Motor Control Timers

- Compact 17.5mm wide
- Brown Out Timer with 2 Functions: ON Delay, Interval
- Detects Voltage Dips and Momentary Loss of Supply & Resets the control panel
- Low Power Consumption
- Fast Response Time
- LED indications for Healthy & Unhealthy conditions
- Excellent Noise Immunity to the latest IEC standards



Cat. No.		17UDT0	13UDT1
Parameters			
Timer Description		Brown Out Timer	
Modes		ON Delay	Interval
Functional Diagram			
Supply Voltage (φ)		230 VAC	110 VAC
Supply Variation		-30% to +10%	
Frequency		50 Hz	60 Hz
Power Consumption (Max.)		10 VA	
Timing Range		0.3s to 30s	
Initiate Time		Max. 100 ms	
Trip Voltage		168 V (± 5 V)	82 V (± 5 V)
Recovery Voltage		Trip Voltage + 14 V (± 5 V)	Trip Voltage + 14 V (± 5 V)
Response Time		25 ms (Max.) (Voltage Dips & Interruptions)	
Setting Accuracy		± 10% @ 30s & ± 20% @ 0.3s	
Repeat Accuracy		± 1%	
Output	Relay Output	1 C/O	
	Contact Rating	5A @ 240 VAC / 28 VDC (Resistive)	
	Electrical Life	1x10 ⁵	
	Mechanical Life	1x10 ⁷	
Utilization Category	AC - 15	Rated Voltage (Ue): 120/240 V, Rated Current (Ie): 3.0/1.5 A	
	DC - 13	Rated Voltage (Ue): 24/125/250 V, Rated Current (Ie): 2.0/0.22/0.1 A	
Operating Temperature		-10°C to +55°C	
Storage Temperature		-15°C to +60°C	
Humidity (Non Condensing)		80% (Rh)	
LED Indication	Green	Healthy	
	Red	Relay ON	
Enclosure		Flame Retardant UL94-V0	
Dimension (W x H x D) (in mm)		17.5 X 58.5 X 90	
Weight (unpacked)		70 g	
Mounting		Base / DIN rail	
Certification			
Degree of Protection		IP 20 for Terminals, IP 40 for Enclosure	
EMI / EMC			
Harmonic Current Emissions		IEC 61000-3-2	Ed. 3.2 (2009-04) Class A
ESD		IEC 61000-4-2	Ed. 2.0 (2008-12) Level II
Radiated Susceptibility		IEC 61000-4-3	Ed. 3.2 (2010-04) Level III
Electrical Fast Transients		IEC 61000-4-4	Ed. 3.0 (2012-04) Level IV
Surges		IEC 61000-4-5	Ed. 2.0 (2005-11) Level IV
Conducted Susceptibility		IEC 61000-4-6	Ed. 3.0 (2008-10) Level III
Voltage Dips & Interruptions (AC)		IEC 61000-4-11	Ed. 2.0 (2004-03) Performance Criteria B
Conducted Emission		CISPR 14-1	Ed. 5.2 (20011-11) Class A
Radiated Emission		CISPR 14-1	Ed. 5.2 (20011-11) Class A
Environmental			
Cold Heat		IEC 60068-2-1	Ed. 6.0 (2007-03)
Dry Heat		IEC 60068-2-2	Ed. 5.0 (2007-07)
Vibration		IEC 60068-2-6	Ed. 7.0 (2007-12) 5g
Repetitive Shock		IEC 60068-2-27	Ed. 4.0 (2008-02) 40g, 6ms
Non-Repetitive Shock		IEC 60068-2-27	Ed. 4.0 (2008-02) 30g, 15ms

ORDERING INFORMATION

Cat. No.	Description
17UDT0	230 VAC, Brown Out Timer (ON Delay), 1 C/O
17UDT1	230 VAC, Brown Out Timer (Interval), 1 C/O
13UDT0	110 VAC, Brown Out Timer (ON Delay), 1 C/O
13UDT1	110 VAC, Brown Out Timer (Interval), 1 C/O

BROWN OUT

A dip in voltage causes electro-mechanical devices such as relays and contactors to drop out and electronic devices such as Timers, Programmable Relays, PLC's remain energized. As a result of this the switch sequence of the panel is lost. This can lock out all or a part of the control system causing the entire system to malfunction.

BROWN OUT TIMER

The 'Brown-Out' Timer also known as 'Mains restoration auto restart timer' is used for detection of voltage dips or momentary loss of supply known as 'Brown out' and initiation of a control panel reset following the Brown out.

Motor Control Timers

- Brown Out Timer with 3 Functions: ON Delay, Interval, Pulse
- Detects Voltage Dips and Momentary Loss of Supply & Resets the control panel
- Low Power Consumption
- Fast Response Time
- LED indications for Healthy & Unhealthy conditions
- Excellent Noise Immunity to the latest IEC standards



Cat. No.	23UDT0		27UDT0	
Parameters				
Timer Description	Brown Out Timer			
Modes	ON Delay, Interval, Pulse			
Functional Diagram				
Supply Voltage (φ)	110 VAC		240 VAC	
Supply Variation	- 40% to +10% (of φ)		- 40% to +10% (of φ)	
Frequency	50/60 Hz		50 Hz	
Power Consumption (Max.)	6 VA		10 VA	
Timing Range	0.3s to 30s		0.3s to 30s	
Initiate Time	Max. 200 ms		Max. 200 ms	
Trip Voltage	81 V (± 6 V)		168 V (± 6 V)	
Recovery Voltage	96 V (± 4 V)		184 V (± 4 V)	
Response Time	Voltage Interruptions	15 ms (Max.)		
	Voltage Dips	30 ms (Max.)		
Setting Accuracy	± 5% of Full scale			
Repeat Accuracy	± 1%			
Output	Relay Output	1 C/O		
	Contact Rating	5A @ 240 VAC / 28 VDC (Resistive)		
	Electrical Life	1x10 ⁵		
	Mechanical Life	1x10 ⁷		
Utilization Category	AC - 15	Rated Voltage (Ue): 120/240 V, Rated Current (Ie): 3.0/1.5 A		
	DC - 13	Rated Voltage (Ue): 24/125/250 V, Rated Current (Ie): 2.0/0.22/0.1 A		
Operating Temperature	-10°C to +55°C			
Storage Temperature	-10°C to +60°C			
Humidity (Non Condensing)	95% (Rh)			
LED Indication	Healthy Condition: Flashing, Unhealthy Condition: Blinking			
	Colour	Amber		Red
Enclosure	Flame Retardant UL94-V0			
Dimension (W x H x D) (in mm)	22.5 X 75 X 100.5			
Weight (unpacked)	130 g			
Mounting	Base / DIN rail			
Certification				
Degree of Protection	IP 20 for Terminals, IP 40 for Enclosure			
EMI / EMC				
Harmonic Current Emissions	IEC 61000-3-2	Ed. 3.2 (2009-04) Class A		
ESD	IEC 61000-4-2	Ed. 2.0 (2008-12) Level II		
Radiated Susceptibility	IEC 61000-4-3	Ed. 3.2 (2010-04) Level III		
Electrical Fast Transients	IEC 61000-4-4	Ed. 3.0 (2012-04) Level IV		
Surges	IEC 61000-4-5	Ed. 2.0 (2005-11) Level IV		
Conducted Susceptibility	IEC 61000-4-6	Ed. 3.0 (2008-10) Level III		
Voltage Dips & Interruptions (AC)	IEC 61000-4-11	Ed. 2.0 (2004-03) Performance Criteria B		
Conducted Emission	CISPR 14-1	Ed. 5.2 (2011-11) Class A		
Radiated Emission	CISPR 14-1	Ed. 5.2 (2011-11) Class A		
Environmental				
Cold Heat	IEC 60068-2-1	Ed. 6.0 (2007-03)		
Dry Heat	IEC 60068-2-2	Ed. 5.0 (2007-07)		
Vibration	IEC 60068-2-6	Ed. 7.0 (2007-12) 5g		
Repetitive Shock	IEC 60068-2-27	Ed. 4.0 (2008-02) 40g, 6ms		
Non-Repetitive Shock	IEC 60068-2-27	Ed. 4.0 (2008-02) 30g, 15ms		

ORDERING INFORMATION

Cat. No.	Description
23UDT0	110 VAC, Brown Out Timer, 1 C/O
27UDT0	240 VAC, Brown Out Timer, 1 C/O

Motor Control Timers

- Single phase Motor Restart Control Timer with Memory Time
- Under Voltage Trip and ON Delay



Cat. No.	22LDT0	23LDT0
Parameters	Motor Restart Control Timer	
Timer Description	Motor Restart Control Timer	
Functional Diagram	<p style="text-align: center;">t: Power Fail Time; Td: Delay Time; Tm: Memory Time</p>	
Supply Voltage (ϕ)	240 VAC	110 VAC
Supply Variation	- 20% to +10% (of ϕ)	
Frequency	50/60 Hz	
Power Consumption (Max.)	4 VA	
Timing Ranges	Memory Time (Tm): 0.2 to 6s, Delay Time (Td): 0.2 to 60s	
Trip Voltage	176 VAC, (\pm 6VAC)	80 VAC, (\pm 6VAC)
Hysteresis	4 VAC to 10 VAC	
Reset Time	200 ms (Max.)	
Setting Accuracy	\pm 5% of Full scale	
Repeat Accuracy	\pm 1%	
Output	Relay Output	1 C/O
	Contact Rating	5A @ 240 VAC / 28 VDC (Resistive)
	Electrical Life	1×10^5
	Mechanical Life	1×10^7
Utilization Category	AC - 15	Rated Voltage (Ue): 120/240 V, Rated Current (Ie): 3.0/1.5 A
	DC - 13	Rated Voltage (Ue): 24/125/250 V, Rated Current (Ie): 2.0/0.22/0.1 A
Operating Temperature	-15°C to +60°C	
Storage Temperature	-20°C to +70°C	
Humidity (Non Condensing)	95% (Rh)	
LED Indication	Green LED \rightarrow Power ON, Red LED \rightarrow Relay ON	
Enclosure	Flame Retardant UL94-V0	
Dimension (W x H x D) (in mm)	22.5 X 75 X 100.5	
Weight (unpacked)	130 g	
Mounting	Base / DIN Rail	
Certification		
Degree of Protection	IP 20 for Terminals, IP 40 for Enclosure	
EMI / EMC		
Harmonic Current Emissions	IEC 61000-3-2	Ed. 3.2 (2009-04) Class A
ESD	IEC 61000-4-2	Ed. 2.0 (2008-12) Level II
Radiated Susceptibility	IEC 61000-4-3	Ed. 3.2 (2010-04) Level III
Electrical Fast Transients	IEC 61000-4-4	Ed. 3.0 (2012-04) Level IV
Surges	IEC 61000-4-5	Ed. 2.0 (2005-11) Level IV
Conducted Susceptibility	IEC 61000-4-6	Ed. 3.0 (2008-10) Level III
Voltage Dips & Interruptions (AC)	IEC 61000-4-11	Ed. 2.0 (2004-03) All 7 Levels
Conducted Emission	CISPR 14-1	Ed. 5.2 (20011-11) Class B
Radiated Emission	CISPR 14-1	Ed. 5.2 (20011-11) Class A
Environmental		
Cold Heat	IEC 60068-2-1	Ed. 6.0 (2007-03)
Dry Heat	IEC 60068-2-2	Ed. 5.0 (2007-07)
Vibration	IEC 60068-2-6	Ed. 7.0 (2007-12) 5g
Repetitive Shock	IEC 60068-2-27	Ed. 4.0 (2008-02) 40g, 6ms
Non-Repetitive Shock	IEC 60068-2-27	Ed. 4.0 (2008-02) 30g, 15ms

ORDERING INFORMATION

Cat. No.	Description
22LDT0	240 VAC, Motor Restart Control Timer, 1 C/O
23LDT0	110 VAC, Motor Restart Control Timer, 1 C/O

WORKING

The timer is used for instantaneous or delayed motor startup after a short-time power failure (max. 6 sec). The start occurs immediately if power supply is disrupted for less than 0.2 sec. If the power failure lasts longer, the relay activates its memory for a time that can be set to 0.2 to 6 sec, after which no automatic restart is possible. If power supply is restored while the memory period is elapsing, the relay commands a motor restart with a delay time from power supply restoration that can be set to 0.2 to 60 sec. A system stop cancels the memory function after 50 ms, and therefore the stop signal should be on for at least this time. The relay is non-sensitive to any control voltage fluctuation or disruption during or after the motor stop.

UL Approval not applicable for Cat No. 23LDT0

Motor Control Timers

MOUNTING DIMENSION (mm)

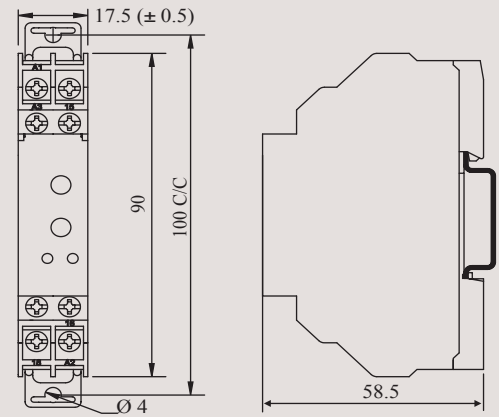
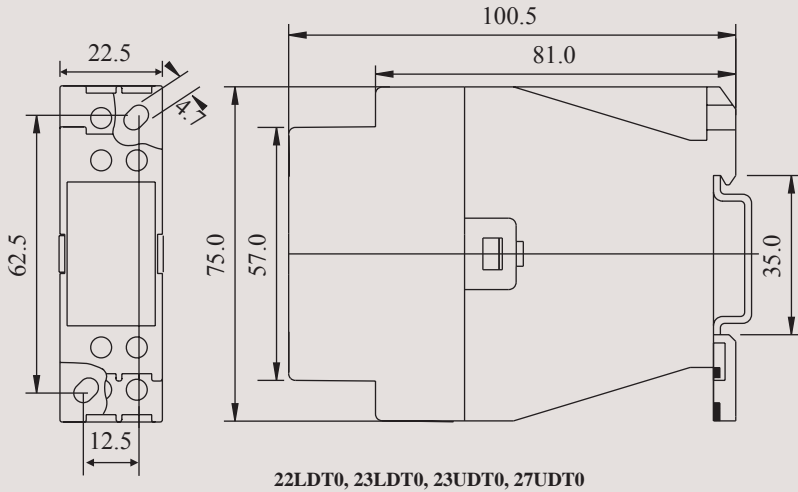

CONNECTION DIAGRAM

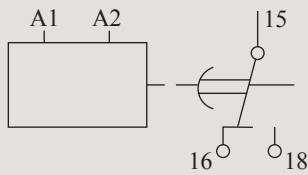

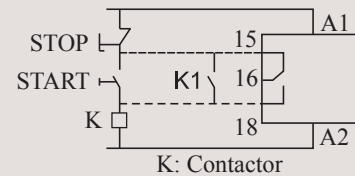

**13UDT0, 17UDT0, 13UDT1, 17UDT1
23UDT0, 27UDT0**





K: Contactor

22LDT0, 23LDT0

TERMINAL TORQUE & TERMINAL CAPACITY

 Ø 3.5...4.0 mm	Torque - 0.6 N.m (6 Lb.in) Terminal screw - M3
	Solid Wire - 1 X 1...4 mm ²
AWG	1 X 18 to 10

22LDT0, 23LDT0, 23UDT0, 27UDT0

 Ø 3.5...5.0 mm	Torque - 1.1 N.m (10 Lb.in) Terminal screw - M3.5
	Solid Wire - 2 X 0.2...2.5 mm ²
AWG	1 X 24 to 10

13UDT0, 17UDT0, 13UDT1, 17UDT1

Synchronous Timer - Series EM 1000

- Time delay is independent of normal voltage and temperature fluctuations
- Black pointer gives clear indication of the time set on the calibrated dial while the red one indicates the time left to complete the cycle
- Automatic reset on de-energisation of the clutch coil
- Base mounting or flush mounting versions
- No-volt feature available

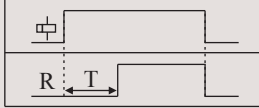
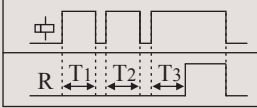

Mode	ON Delay	ON Delay Retentive (No Volt)
Functional Diagram		
Supply Variation	- 20% to +10%	
Frequency Variation	95% to 105%	
Power Consumption (Max.)	10 VAC	
Timing Range	0.15s to 120h	
Repeat Accuracy	± 0.5% of Full Scale Range @ Constant Frequency	
Output	Output Contact	1 Instant + 1 Delayed / 1 Instant + 2 Delayed (Optional)
	Contact Rating	6A (resistive) @ 250 VAC
	Switching Frequency	3000 operations/hr. (Max.)
Operating Temperature	-5°C to 45°C	
Enclosure	Conforms to IP30 - IS 13947.	
Dimension (W x H x D) (in mm)	96 X 96 X 100	
Weight (unpacked)	530 g	
Mounting	Flush / Base	
Terminal Connection	1– 2.5 mm ² solid/stranded.	
Degree of Protection	IP20	

ORDERING INFORMATION

Timing Ranges(SR)	B <input type="checkbox"/> <input type="checkbox"/> <input type="checkbox"/> <input type="checkbox"/> <input type="checkbox"/>	
B 0.15 - 3.0 SEC		Delay
C 1.5 - 30 SEC		1 Standard ON delay
D 0.15 - 3.0 MIN		2 With 'NO VOLT'
E 1.5 - 30 MIN		
F 0.15 - 3.0 HRS		Mounting
G 1.5 - 30 HRS		B Base Mounting
H 0.3 - 6.0 SEC		F Flush (door) Mtg.
J 3.0 - 60 SEC		Contact
K 0.3 - 6.0 MIN		1 1 Inst + 1 Del C/O
L 3.0 - 60 MIN		2 1 Inst + 2 Del C/O
M 0.3 - 6.0 HRS		
N 3.0 - 60 HRS		Timing Ranges(MR)
P 0.6 - 12 SEC	X 0.15 SEC.-3.0 HRS.	Voltage
Q 6.0 - 120 SEC	Y 0.3 SEC.- 6.0 HRS.	3 110V AC 50 Hz
R 0.6 - 12 MIN	Z 0.6 SEC.-12.0 HRS.	4 240V AC 50 Hz
S 6.0 - 120 MIN		C 110V AC 60 Hz
T 0.6 - 12 HRS		D 240V AC 60 Hz
V 6 - 120 HRS		

Synchronous Timer - Series EM 2000

- Time delay is independent of normal voltage & temperature fluctuations
- Large knob operating on a linear scale makes time setting easy
- Set time is indicated by a fixed pointer of the setting knob.
- Time left for completion of cycle is indicated by red pointer
- Wiring is quicker and easier as terminals are in the front of the unit
- All part subjected to wear & tear are made of 'Delrin' which has high resistance to wear & tear and thus ensures longer life.



Mode	ON Delay	
Functional Diagram		
Supply Variation	- 20% to +10%	
Frequency Variation	95% to 105%	
Timing Range	1s to 120s	
Repeat Accuracy	± 2% of Full Scale Range at Constant Frequency	
Output	Output Contact	1 Delayed C/O or 2 Delayed C/O (Resistive)
	Contact Rating	5A @ 250 VAC (Resistive)
	Switching Frequency	1000 operations / hr. (Max.)
Operating Temperature	-5°C to 45°C	
Enclosure	Conforms to IP30 - IS 13947.	
Dimension (W x H x D) (in mm)	55 X 88 X 106	
Weight (unpacked)	260 g	
Mounting	Base/DIN Mounting & can be mounted on vertical plane with maximum inclination of 15° from vertical.	
Terminal Connection	1– 2.5 mm ² solid/stranded.	
Degree of Protection	IP20	

ORDERING INFORMATION

Timing Ranges	Voltage	Contact
C 1.0 - 30 Sec	3 110V AC 50 Hz	5 1 Del C/O
J 2.0 - 60 Sec	4 240V AC 50 Hz	6 2 Del C/O
Q 4.0 - 120 Sec	5 415V AC 50 Hz	

MOUNTING DIMENSION (mm)

EM 1000

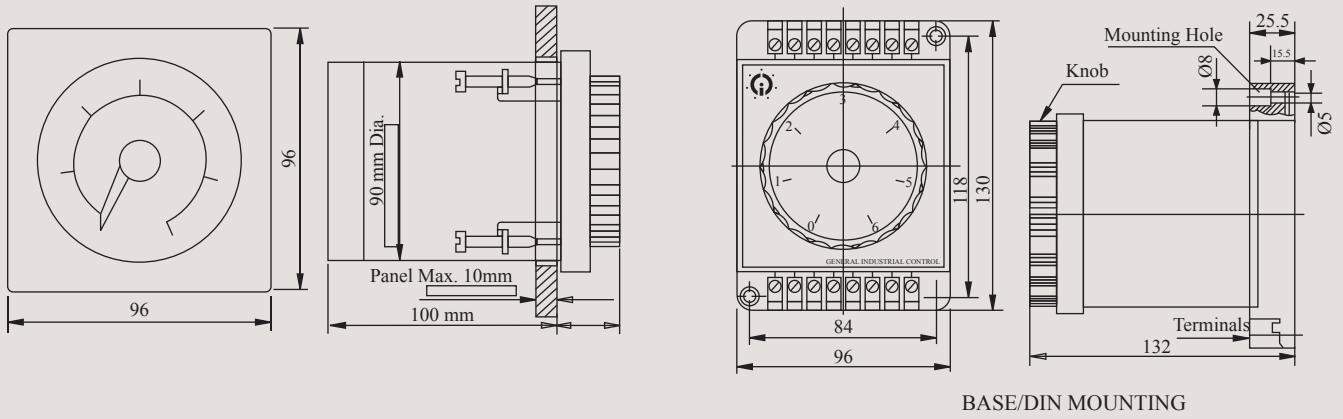

EM 2000

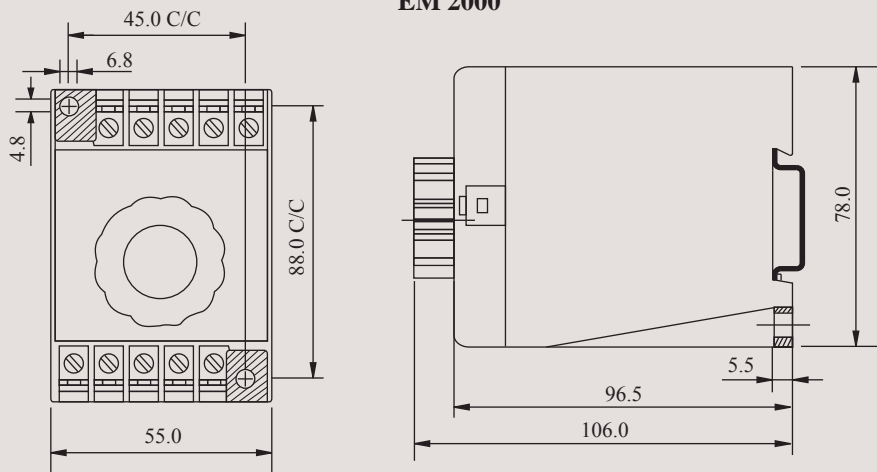

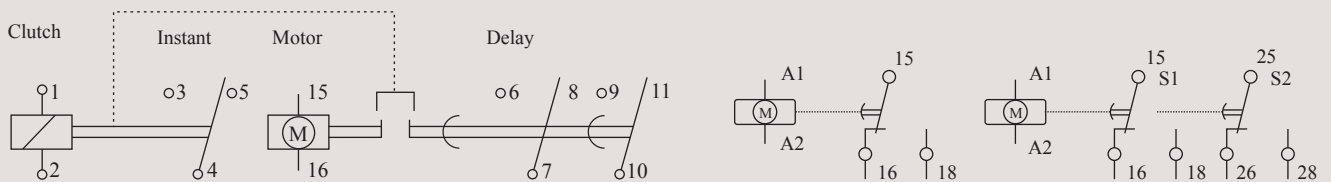

CONNECTION DIAGRAM



EM 1000

EM 2000

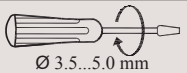
TERMINAL TORQUE & CAPACITY

 Ø 3.5...5.0 mm	Torque - 1.1 N.m (10 Lb.in) Terminal screw - M3.5
	Solid Wire - 2 X 0.2...2.5 mm ²
AWG	1 X 24 to 10

EM 1000, EM 2000

Basic Operating Modes / Functions

Φ : SUPPLY, S: SIGNAL, R: RELAY OUTPUT,
 T: SET TIME, TP: PAUSE TIME, T_{ON}: ON TIME, T_{OFF}: OFF TIME, T₁,T₂,T₃: POWER DOWN REGION

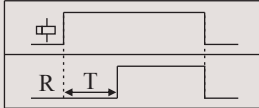

• **ON DELAY (DELAY ON ENERGIZATION):**

On application of supply voltage to the timer, the preset delay time period starts. On completion of the preset time, the output is switched ON and remains ON till the supply voltage is present

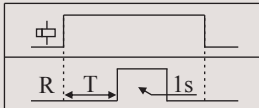

• **ONE SHOT (PULSE):**

On application of supply voltage to the timer, the preset delay time period starts. On completion of the preset time, the output is switched ON for a period of one second after which it is switched OFF.

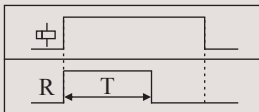

• **INTERVAL (IMPULSE ON):**

On application of supply voltage to the timer, the output is instantly switched ON for the preset time period. On completion of the preset time, the output is switched OFF.

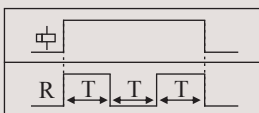

• **CYCLIC ON/OFF (SYMMETRIC):**

On application of supply voltage, the output is initially switched ON for the preset time duration (T) after which it is switched OFF for the same time duration (T). This cycle repeats and continues till the supply is present.

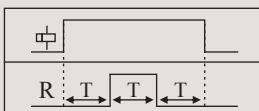

• **CYCLIC OFF/ON (SYMMETRIC):**

On application of supply voltage, the output is initially switched OFF for the preset time duration (T) after which it is switched ON for the same time duration (T). This cycle repeats and continues till the supply is present.

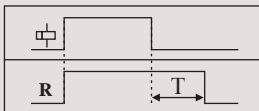

• **TRUE OFF DELAY (POWER OFF DELAY):**

On application of supply voltage, the output relay energizes instantly. On removal of supply voltage to the timer, the preset delay time period starts. On completion of the preset time, the output is switched OFF.

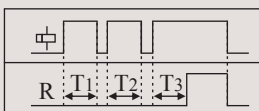

• **ON DELAY RETENTIVE (NO VOLT):**

On application of supply voltage to the timer, the preset delay time period starts. On completion of the preset time, the output is switched ON and remains. If power fails during preset time duration, the elapsed time is retained by timer. Upon resumption of power, the remaining cycle continues.



• **ASYMMETRIC ON-OFF / CYCLIC ON-OFF (ASYMMETRIC):**

On application of supply voltage, the output is initially switched ON for the preset 'ON' time duration (T) after which it is switched OFF for the preset 'OFF' time duration (T). This cycle repeats and continues till the supply is present. The ON time & OFF time are set independently.

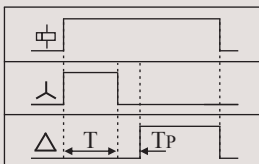

• **STAR DELTA:**

On application of supply voltage, the output Star relay energizes instantly. On completion of the preset delay time, the output Delta relay energizes after a fixed pause time. This pause time (60, 90, 120, 150 ms) provides the shortest possible 'current off' pause and simultaneously ensures smooth change over.

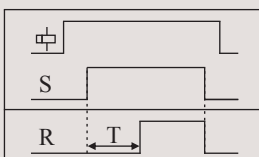

• **SIGNAL ON DELAY:**

On application of input signal to the timer, the preset delay time period starts. On completion of the preset time, the output is switched ON and remains ON till the input signal is present.

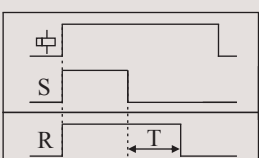

• **SIGNAL OFF DELAY:**

On application of input signal, the output relay energizes instantly. On removal of input signal to the timer, the preset delay time period starts. On completion of the preset time, the output is switched OFF.

TIME SWITCHES

Time Switch FM Series

Digital Time Switch *Crono*[®] & *Pulse*

Astronomical Time Switch *Astro*[®] *Mini*

Astronomical Time Switch *Astro*[®]

Lighting Automation with *Astro*[®] Using GSM Technology

Time Switch FM Series

- Modular construction
- Inbuilt over-ride facility
- High switching capacity
- Tamper proof sealing
- Analog & Digital version
- Daily/Weekly programming
- Graphical Program LCD



Cat. No.	J648B1	D847B2
Parameters		
Supply Voltage Φ	240 VAC	
Frequency	50/60 Hz	
Power Consumption (Max.)	2 VA	4.4 VA
Accuracy	± 1.5 s/day at 20°C	± 1 s/day at 20°C
Relay Output	1 C/O	1 C/O
Contact Rating	Resistive	16A @ 250 VAC, 0.25A @ 220VDC
	Inductive (cos ϕ = 0.6)	8A @ 250 VAC, 0.1A @ 220 VDC
	Incandescent Lamp	1350 W
Shortest Switching Time	Daily	15min
	Weekly	2h
Power reserve	150h	10 years from Factory at 20°C
Memory locations	N. A.	20
Storage Temperature	- 20°C to + 55°C	
Manual Over-ride	Provided	
Mounting	Flush, Base / DIN rail	
Weight (unpacked)	185 g	

ORDERING INFORMATION

Cat. No.	Description	
J648B1	FM/1 QT	240 VAC, Daily Dial, Base / DIN Mounting
J848B1	FM/1 QW	240 VAC, Weekly Dial, Base / DIN Mounting
J638B1	FM/1 QT	110 VAC, Daily Dial, Base / DIN Mounting
J838B1	FM/1 QW	110 VAC, Weekly Dial, Base / DIN Mounting
D847B2	FM/1 Digi20 Plus	240 VAC, Daily / Weekly, Base / DIN Mounting

Note: For Flush Mounting model, replace B by F in Cat. No.

MOUNTING DIMENSION (mm)

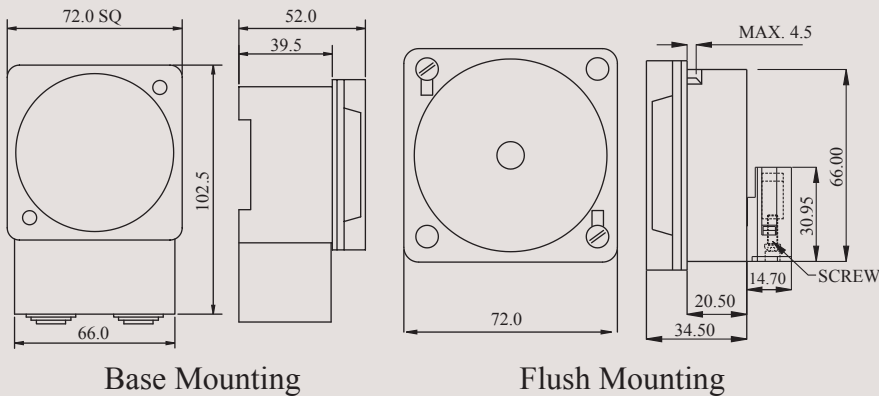

CONNECTION DIAGRAM

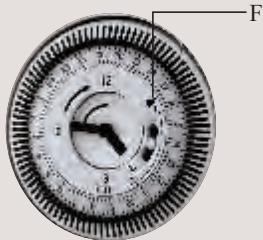
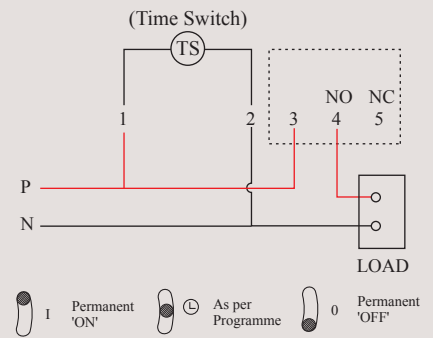



TIME SETTING:

Rotate the switching Dial in clockwise direction until the current time (day / time incase of weekly model) is almost opposite to the marking arrow F. For fine adjustment rotate the minute hand in the clockwise direction until the clock shows the current time.

PROGRAMMING:

Required Switch ON time is set on the Switching Dial by radially pulling outwards the corresponding black segments. Each segment on daily dial corresponds to 15 mins. & on weekly Dial corresponds to 2 hours.

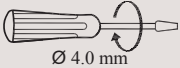

TERMINAL TORQUE & CAPACITY

 Ø 4.0 mm	Torque - 1.1 N.m (10 Lb.in) Terminal screw - M3.5
	Solid Wire - 1 X 0.2...5 mm ²
AWG	1 X 24 to 10

Digital Time Switches *Crono*[®] & *Pulse*



- Precise time programming for Daily/Weekly/Pulse switching
- 25 ON/OFF programs
- Weekend Exclusion (FRI SAT or SAT SUN) and Weekly OFF programming
- LED Indication of Relay status
- 12/24 h display formats
- 6 Years Battery reserve
- Simple Reset & Manual override
- Settable DST & Keypad Lock Feature

Cat. No.	67DDT0 (<i>Crono</i> [®])	67DDT9 (<i>Pulse</i>)
Parameters		
Supply Voltage	110 - 240 VAC	
Supply Variation	-20 % to +10%	
Frequency	50/60 Hz	
Power Consumption (Max.)	6 VA	
Number of Programs	25 ON/OFF Programs	16 Pulse Programs
Minimum Switching Time	1 min	1 s
Pulse Duration	N A	1 to 59 s (Programmable)
Number of Operating Modes	5	3
Description of Modes	<ul style="list-style-type: none"> • AUTO - Program Run • ON AUTO - Instant ON up to next Auto Event • AUTO OFF - Instant OFF up to next Auto Event • ON - Continuous ON • OFF - Continuous OFF 	<ul style="list-style-type: none"> • AUTO - Program Run • ON - Continuous ON • OFF - Continuous OFF
Display	3 Lines Text LCD	
DST	Programmable	
Clock Accuracy	± 2 s/day max. over the Operating Temperature range	
Power Reserve from Factory	6 Years	
Output	Relay Output	1 C/O
	Contact Rating	16A (For 'NO') & 5A (For 'NC') @ 240 VAC / 24 VDC (Resistive), Inductive (cos ϕ = 0.6) :- 6 A @ 250 VAC
	Electrical Life	3x10 ⁴
	Mechanical Life	5x10 ⁴
Utilization Category	AC - 15	Rated Voltage (Ue): 120/240 V, Rated Current (Ie): 3/1.5 A
	DC - 13	Rated Voltage (Ue): 24/125/250 V, Rated Current (Ie): 2.0/0.22/0.11 A
Operating Temperature	-10°C to + 55°C	
Storage Temperature	-10°C to + 60°C	
Humidity (Non Condensing)	95% (Rh)	
LED Indication	Red LED → Relay ON	
Enclosure	Flame Retardant UL94-V0	
Dimension (W x H x D) (in mm)	36 X 90 X 65	
Weight (unpacked) Approx.	110 g	
Mounting	Base / DIN rail	
Certification	  	
Degree of Protection	IP 20 for Terminals, IP 40 for Enclosure	
EMI / EMC		
Harmonic Current Emissions	IEC 61000-3-2	Ed. 3.2 (2009-04) Class A
ESD	IEC 61000-4-2	Ed. 2.0 (2008-12) Level II
Radiated Susceptibility	IEC 61000-4-3	Ed. 3.2 (2010-04) Level III
Electrical Fast Transients	IEC 61000-4-4	Ed. 3.0 (2012-04) Level IV
Surges	IEC 61000-4-5	Ed. 2.0 (2005-11) Level IV
Conducted Susceptibility	IEC 61000-4-6	Ed. 3.0 (2008-10) Level III
Voltage Dips & Interruptions (AC)	IEC 61000-4-11	Ed. 2.0 (2004-03) All 7 Levels
Conducted Emission	CISPR 14-1	Ed. 5.2 (20011-11) Class A
Radiated Emission	CISPR 14-1	Ed. 5.2 (20011-11) Class A
Environmental		
Cold Heat	IEC 60068-2-1	Ed. 6.0 (2007-03)
Dry Heat	IEC 60068-2-2	Ed. 5.0 (2007-07)
Vibration	IEC 60068-2-6	Ed. 7.0 (2007-12) 5g
Repetitive Shock	IEC 60068-2-27	Ed. 4.0 (2008-02) 40g, 6ms
Non-Repetitive Shock	IEC 60068-2-27	Ed. 4.0 (2008-02) 30g, 15ms
Applications	Ideal for Lighting applications like street lighting, Advertising Displays, Glowsigns. Also can be used for Air conditioners / Coolers, Geysers, conveyors, pumps etc.	Ideal for Siren, Bell applications

ORDERING INFORMATION

Cat. No.	Description
67DDT0	110 - 240 VAC, Digital Time Switch - Crono, 1 C/O
6GHDT0	24 VDC, Digital Time Switch - Crono, 1 C/O
69HDT0	12 VDC, Digital Time Switch - Crono, 1 C/O
67DDT9	110 - 240 VAC, Digital Time Switch - Pulse, 1 C/O
6GHDT9	24 VDC, Digital Time Switch - Pulse, 1 C/O
69HDT9	12 VDC, Digital Time Switch - Pulse, 1 C/O

Astronomical Time Switch *Astro[®] Mini*

- Astronomical Time Switch in 35mm
- Latitude/Longitude precise to the minute with time zone
- Sunrise/Sunset or Twilight rise/set trigger modes
- Ease of Programming & Navigation
- DST, Offset, OFF Hours, Weekly OFF features
- 12/24 Hour display format
- 6 years Battery reserve
- Easy Manual Override & Keypad Lock feature
- Ideal for Outdoor & Street lighting applications



Cat. No.		T2DDT7
Parameters		
Supply Voltage (φ)	110 - 240 VAC	
Supply Variation	-20 % to +10% (of φ)	
Frequency	50/60 Hz	
Power Consumption	6 VA	
Programming	Based on Latitude/Longitude precise to the minute with time-zone	
Trigger Modes	Sunrise/Sunset or Twilight Rise/Set	
Offset	1 min to 10 hr 59 min (Programmable)	
OFF Hours	Programmable	
Weekly Off	User Defined	
DST	User Defined	
Number of Operating Modes	3	
Description of Modes	<ul style="list-style-type: none"> • AUTO - As per user defined program settings • ON AUTO - Instant ON up to next Auto Event • AUTO OFF - Instant OFF up to next Auto Event 	
Minimum Switching Time	1 min	
Display	3 Lines Text LCD	
Clock Accuracy	± 2 s/day max. over the Operating Temperature range	
Power Reserve from Factory	6 Years	
Output	Relay Output	1 C/O
	Contact Rating	16A (For 'NO') & 5A (For 'NC') @ 240 VAC / 24 VDC (Resistive), Inductive (cos φ = 0.6) :- 6 A @ 250 VAC
	Electrical Life	3x10 ⁴
	Mechanical Life	5x10 ⁴
Utilization Category	AC - 15	Rated Voltage (Ue): 120/240 V, Rated Current (Ie): 3/1.5 A
	DC - 13	Rated Voltage (Ue): 24/125/250 V, Rated Current (Ie): 2.0/0.22/0.11 A
Operating Temperature	-10°C to + 55°C	
Storage Temperature	-10°C to + 60°C	
Humidity (Non Condensing)	95% (Rh)	
LED Indication	Red LED → Relay ON	
Enclosure	Flame Retardant UL94-V0	
Dimension (W x H x D) (in mm)	36 X 90 X 65	
Weight (unpacked)	110 g	
Mounting	Base / DIN rail	
Certification		
Degree of Protection	IP 20 for Terminals, IP 40 for Enclosure	
EMI / EMC		
Harmonic Current Emissions	IEC 61000-3-2	Ed. 3.2 (2009-04) Class A
ESD	IEC 61000-4-2	Ed. 2.0 (2008-12) Level II
Radiated Susceptibility	IEC 61000-4-3	Ed. 3.2 (2010-04) Level III
Electrical Fast Transients	IEC 61000-4-4	Ed. 3.0 (2012-04) Level IV
Surges	IEC 61000-4-5	Ed. 2.0 (2005-11) Level IV
Conducted Susceptibility	IEC 61000-4-6	Ed. 3.0 (2008-10) Level III
Voltage Dips & Interruptions (AC)	IEC 61000-4-11	Ed. 2.0 (2004-03) All 7 Levels
Conducted Emission	CISPR 14-1	Ed. 5.2 (20011-11) Class A
Radiated Emission	CISPR 14-1	Ed. 5.2 (20011-11) Class A
Environmental		
Cold Heat	IEC 60068-2-1	Ed. 6.0 (2007-03)
Dry Heat	IEC 60068-2-2	Ed. 5.0 (2007-07)
Vibration	IEC 60068-2-6	Ed. 7.0 (2007-12) 5g
Repetitive Shock	IEC 60068-2-27	Ed. 4.0 (2008-02) 40g, 6ms
Non-Repetitive Shock	IEC 60068-2-27	Ed. 4.0 (2008-02) 30g, 15ms
Applications	Street lighting applications in cities, industrial townships, university campuses Lighting automation in sports complex, hotels, parks & other outdoor applications.	



ORDERING INFORMATION

Cat. No.	Description
T2DDT7	110 - 240 VAC, Astronomical Time Switch - Astro Mini, 1 C/O
T2DDT8	110 - 240 VAC, Astronomical Time Switch - Astro Mini, 1 C/O (With Pre-defined City codes)

Astronomical Time Switch *Astro*[®]

- Dynamic and Accurate control based on Astronomical Mathematics
- Sunrise / Sunset or Twilight rise / set trigger
- Yearly programming with Season mode, DST, Offset, OFF hours, Weekly Off features
- Protection against Under Voltage and Over Voltage
- Alternate Mode with Auto Load Changeover feature
- Three Independent channel outputs
- Active Phase selection
- Manual override facility
- Single phase and Three phase versions
- Modbus Communication
- User friendly software for device configuration



Cat. No.	T2DDT0		T3DDT0
Parameters			
Supply Voltage (φ)	110 - 240 VAC		110 - 240 VAC (3 Phase, 4 Wire)
Supply Variation	-20 % to +10% (of φ)		
Frequency	50/60 Hz		
Programming	Based on Latitude/Longitude precise to the minute with time-zone		
Trigger Modes	Sunrise/Sunset or Twilight Rise/Set		
Offset	1 min to 10 hr 59 min (Programmable)		
OFF Hours	Programmable		
Weekly Off	User Defined		
Alternate Mode	Yes		
Seasonal Mode	User Defined		
DST	User Defined		
Number of Operating Modes	3		
Mode Description	<ul style="list-style-type: none"> • AUTO - As per user defined program settings • ON AUTO - Instant ON up to next Auto Event • AUTO OFF - Instant OFF up to next Auto Event 		
Minimum Switching Time	1 min (1s for Pulse)		
Display	Backlit LCD		
Under Voltage Trip Level	N A		0 - 220 V (Settable)
Over Voltage Trip Level	N A		130 - 330 V (Settable)
Trip Time	N A		5 - 16 sec
Recovery Time	N A		1 - 4 sec
Clock Accuracy	± 1 s/day max. over the Operating Temperature range		
Power Reserve from Factory	1000 Hours (For Clock Only)		
Output	Relay Output	2 NO	3 NO
	Contact Rating	8A @ 240 VAC & 5A @ 30 VDC (Resistive),	
	Electrical Life	1x10 ⁵	
	Mechanical Life	1x10 ⁷	
Utilization Category	AC - 15	Rated Voltage (Ue): 120/240 V, Rated Current (Ie): 3/1.5 A	
	DC - 13	Rated Voltage (Ue): 24/125/250 V, Rated Current (Ie): 2.0/0.22/0.11 A	
Operating Temperature	-10°C to + 50°C		
Storage Temperature	-10°C to + 60°C		
Humidity (Non Condensing)	95% (Rh)		
Enclosure	Flame Retardant UL94-V0		
Dimension (W x H x D) (in mm)	72 X 90 X 67		
Weight (unpacked)	190 g		208 g
Mounting	Base / DIN rail		
Certification	  		
Degree of Protection	IP 20 for Terminals, IP 40 for Enclosure		
EMI / EMC			
Harmonic Current Emissions	IEC 61000-3-2	Ed. 3.2 (2009-04) Class A	
ESD	IEC 61000-4-2	Ed. 2.0 (2008-12) Level II	
Radiated Susceptibility	IEC 61000-4-3	Ed. 3.2 (2010-04) Level III	
Electrical Fast Transients	IEC 61000-4-4	Ed. 3.0 (2012-04) Level IV	
Surges	IEC 61000-4-5	Ed. 2.0 (2005-11) Level IV	
Conducted Susceptibility	IEC 61000-4-6	Ed. 3.0 (2008-10) Level III	
Voltage Dips & Interruptions (AC)	IEC 61000-4-11	Ed. 2.0 (2004-03) All 7 Levels	
Conducted Emission	CISPR 14-1	Ed. 5.2 (20011-11) Class A	
Radiated Emission	CISPR 14-1	Ed. 5.2 (20011-11) Class A	
Environmental			
Cold Heat	IEC 60068-2-1	Ed. 6.0 (2007-03)	
Dry Heat	IEC 60068-2-2	Ed. 5.0 (2007-07)	
Vibration	IEC 60068-2-6	Ed. 7.0 (2007-12) 5g	
Repetitive Shock	IEC 60068-2-27	Ed. 4.0 (2008-02) 40g, 6ms	
Non-Repetitive Shock	IEC 60068-2-27	Ed. 4.0 (2008-02) 30g, 15ms	

ORDERING INFORMATION

Cat. No.	Description
T2DDT0	110 - 240 VAC, Single Phase Astronomical Time Switch - Astro, 2 NO
T3DDT0	110 - 240 VAC, Three Phase Astronomical Time Switch - Astro, 3 NO
TGDDT6	Windows based Application software for Astro
GFDNN3M	Memory Card
GFDNN2S	RS 232 Serial Interface Cable
GFDNN1	USB Interface Cable



MOUNTING DIMENSION (mm)

Astro[®]

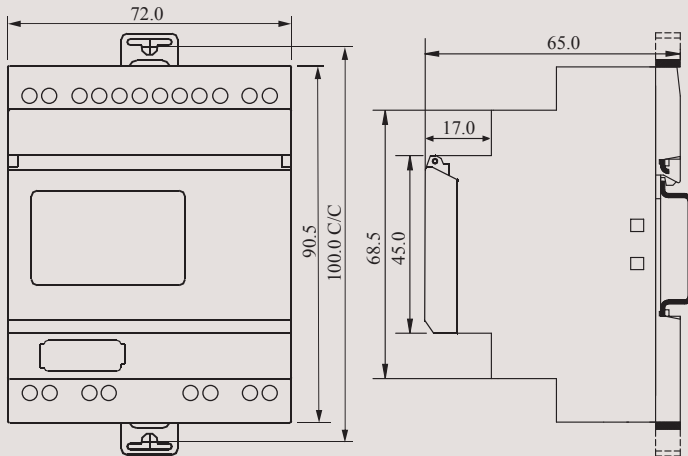

T2DDT0, T3DDT0

Crono[®], *Pulse* & *Astro*[®] *Mini*

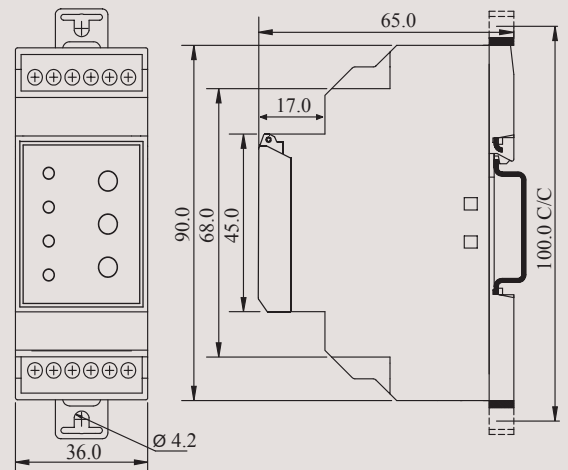

67DDT0, 67DDT9, T2DDT7, T2DDT8

CONNECTION DIAGRAM

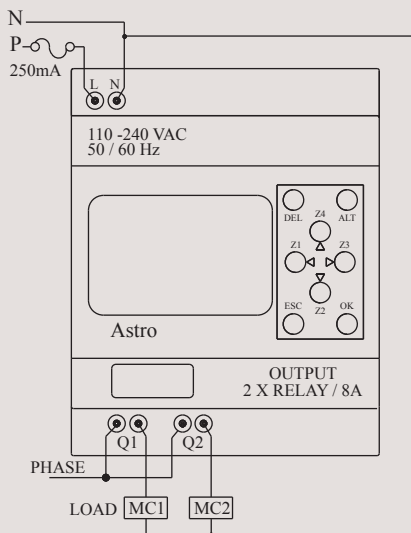

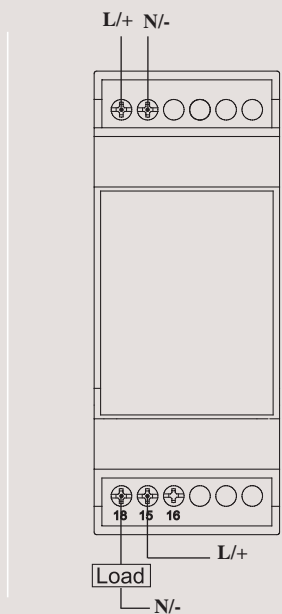
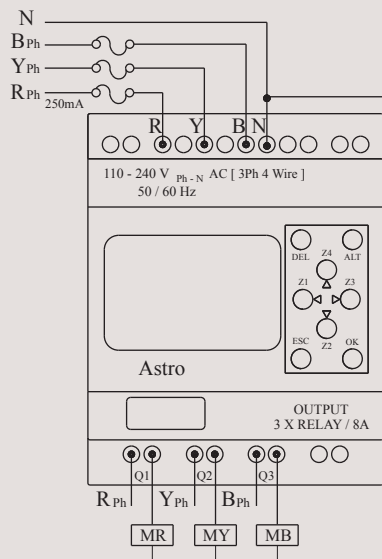

T2DDT0, T3DDT0

MC1, MC2, MR, MY, MB: CONTACTOR COILS

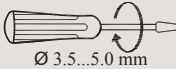

67DDT0, 6GHDT0, 6GHDT9, 67DDT9, 69HDT0, 69HDT9, T2DDT7, T2DDT8

TERMINAL TORQUE & CAPACITY

 Ø 3.5...5.0 mm	Torque - 1.1 N.m (10 Lb.in) Terminal screw - M3.5
	Solid Wire - 2 X 0.2...2.5 mm ²
AWG	1 X 24 to 10

T2DDT0, T3DDT0, T2DDT7, T2DDT8, 67DDT0, 67DDT9

Lighting Automation with *Astro*[®] using GSM Technology



- Most of the "ASTRO" parameters can be set remotely using SMS queries. I.e. Output mode, Offset Hrs etc, UV, OV settings.
- Relay Output can be override remotely using SMS query.
- Energy Meter Functionality. Parameter like Load current, Supply voltage, Power, Energy can be known remotely.
- With the help of "Auto Error Code Update" following onsite error can be know remotely during output event.
 - Under Voltage
 - Over Voltage
 - Over Current
 - Output actuator short.
 - Load Open

Cat. No.	19D20B00 (ERT 5)	19C20C00
Parameters		
Supply Voltage (≡)	240 VAC (3 Phase, 4 Wire)	240 VAC (1 Phase)
Supply Variation	-30% to +25% (of≡)	
Frequency	50/60 Hz	
Active Phase selection	Yes	
Operating Temperature	-15°C to + 60°C	
GSM Type	Dual band 900 / 1800 GSM	
GPRS Packet data	Class 10 coding scheme	
AT cCommand set Suitability	N. A.	Yes
SMS Type Functionality	Data Call through GSM, SMS	GSM 7.05 & 7.07
SIM Holder	Text, Cell Broadcast	
Antenna	Connected with the product	
Antenna Impedance	50 Ω	
Energy Measurement	Yes	No
Energy Measurement Accuracy	Class 0.5	N. A.
Current Sensing Range	5A	N. A.
CT Ratio	Settable up to 40	N. A.
LED Indications	Tx, Rx, Network, Power, Pulse Out	Tx, Rx, Network, Power, SIM Status
Pulse Out rate	3200 pulses / kWh	N. A.
Auxiliary Output	12 V DC, 200 mA	N. A.
General Port Connectivity		TTL port for connecting Time-switch (Astro) USB through USB interface cable GFDNN1, RS232 through serial interface GFDNN2S, RS485 through TTL-RS485 converter G7XDTR4"
Mounting	Base / DIN Rail	
Enclosure	Flame Retardant UL94-V0	
Dimension (W x H x D) (in mm)	72 X 90 X 67	
Weight (unpacked)	190 g	
Certification		
EMI / EMC		
Harmonic Current Emissions	IEC 61000-3-2	Ed. 3.2 (2009-04) Class A
ESD	IEC 61000-4-2	Ed. 2.0 (2008-12) Level II
Radiated Susceptibility	IEC 61000-4-3	Ed. 3.2 (2010-04) Level III
Electrical Fast Transients	IEC 61000-4-4	Ed. 3.0 (2012-04) Level IV
Surges	IEC 61000-4-5	Ed. 2.0 (2005-11) Level IV
Conducted Susceptibility	IEC 61000-4-6	Ed. 3.0 (2008-10) Level III
Voltage Dips & Interruptions (AC)	IEC 61000-4-11	Ed. 2.0 (2004-03) All 7 Levels
Conducted Emission	CISPR 14-1	Ed. 5.2 (20011-11) Class A
Radiated Emission	CISPR 14-1	Ed. 5.2 (20011-11) Class A
Environmental		
Cold Heat	IEC 60068-2-1	Ed. 6.0 (2007-03)
Dry Heat	IEC 60068-2-2	Ed. 5.0 (2007-07)
Vibration	IEC 60068-2-6	Ed. 7.0 (2007-12) 5g
Repetitive Shock	IEC 60068-2-27	Ed. 4.0 (2008-02) 40g, 6ms
Non-Repetitive Shock	IEC 60068-2-27	Ed. 4.0 (2008-02) 30g, 15ms

Note:

1. ERT5 & ERT1 can measure maximum 5A & 1A current respectively.

2. Maximum current measurement limit for ERT-5 is 200A & for ERT-1 it is 40A.

Ex: 1. For CT selection if current required to be measured is upto 200A then CT of 200:5 A (CT ratio 40) needs to be used.

2. For CT selection if current required to be measured is upto 40A then CT of 40:1 A (CT ratio 40) needs to be used.

ORDERING INFORMATION

Cat. No.	Description
19D2000C	Surge Suppressor
19D20A00	Astro GSM Module (GSM-ERT1), Remote Side
19D20B00	Astro GSM Module (GSM-ERT5), Remote Side
19C20C00	Astro GSM Module (GSM-RT), PC side
19A1000B	Communication Cable (TTL-TTL) between Astro & GSM Module
TGDDT6	Windows based application software for Astro

Lighting Automation with *Astro*[®] using GSM Technology



- Maximum 5 valid users can access the system remotely, using GSM functionality.
- To avoid Remote module's SIM theft, "SIM PIN" facility can be enabled remotely using SMS query.
- To avoid changes in system configuration by unauthorized user amongst valid users, important SMS queries are provided with "MODULE PIN" lock.
- Device supports for 12 to 14 digit mobile number. i.e. (10 Digit Mobile number + 2/3/4 digit country code).

CONNECTION DIAGRAM

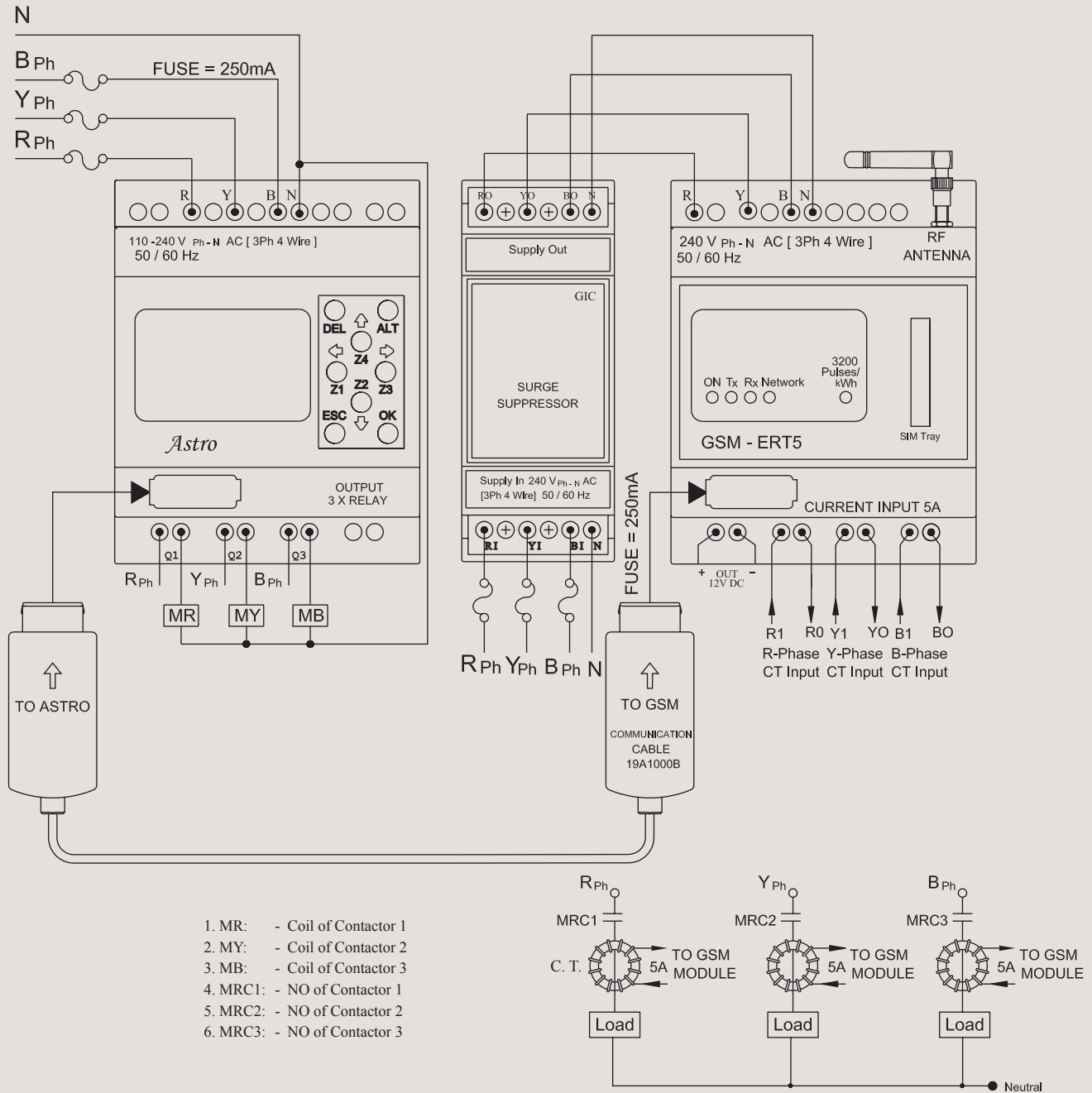

TERMINAL TORQUE & CAPACITY

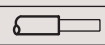
 Ø 3.5...5.0 mm	Torque - 1.1 N.m (10 Lb.in) Terminal screw - M3.5
	Solid Wire - 2 X 0.2...2.5 mm ²
AWG	1 X 24 to 10

HRUR METERS & COUNTERS

Hour Meter Series HM 36

Digital Hour Meter & Counter

Digital Hour Meter

Impulse Counter Series CR 18

Impulse Counter Series CR 26

Impulse Counter Series CR 36

Digital Counters

Hour Meter Series HM36

- Robust design with high degree of Accuracy and Compact size
- Frequency independent for AC applications
- Indicates operating time in hours and tenths with running indicators
- Totally sealed from Dust and Moisture
- Panel mountable with 7 Bezel options
- 6 Digit Non-Resettable with automatic recycle to zero
- Wide supply voltage range: 4 - 30V AC/DC, 10 - 80V DC & 90 - 264V AC
- Shock & Vibration Proof



Cat. No.	LA25F1	LD15F1	LC36F1
Parameters			
Supply Voltage (中)	90 - 264 VAC	10 - 80 VDC	4 - 30 VAC/DC
Frequency	50/60 Hz	N A	50/60 Hz
Over Voltage & Reverse Polarity Protection	N A	Protected for 2 times Battery voltage and / or Reverse polarity	Not applicable to AC and 48V for DC Application
Power Consumption (Max.)	0.5 VA	0.25 VA	1 VA
Bezel	Square Mount	Cup Mount	Stirrup Mount
Register	6 Digit (3.6mm)		
Read Out	99999.9		
Least Count	1/10 h		
Accuracy	± 0.02% over entire range		
Vibration	10-80Hz with 20g max (SAE J1378)		
Shock	55g @ 9-13ms (SAE J1378)		
Weight (unpacked)	47g		
Temperature	-40° C to +85° C		
Humidity (Non Condensing)	95% (Rh)		
Mounting	Panel		
Termination	¼" [6.3] Spade Terminal		
Degree of Protection	IP 66		
Approvals	SAE & NEMA 4X		SAE & NEMA 4X

ORDERING INFORMATION

Cat. No.	Description
LA21F1	90 - 264 VAC, Rectangular Bezel
LA22F1	90 - 264 VAC, Rectangular 2 holes Bezel
LA23F1	90 - 264 VAC, Round Bezel
LA24F1	90 - 264 VAC, Round 3 holes Bezel
LA25F1	90 - 264 VAC, Square Mount Bezel
LA26F1	90 - 264 VAC, Cup Mount Bezel
LA27F1	90 - 264 VAC, Stirrup Mount Bezel
LD11F1	10 - 80 VDC, Rectangular Bezel
LD12F1	10 - 80 VDC, Rectangular 2 holes Bezel
LD13F1	10 - 80 VDC, Round Bezel
LD14F1	10 - 80 VDC, Round 3 holes Bezel
LD15F1	10 - 80 VDC, Cup Mount Bezel
LD16F1	10 - 80 VDC, Stirrup Mount Bezel
LD17F1	10 - 80 VDC, Square Mount Bezel
LC31F1	4 - 30 VAC/DC, Rectangular Bezel
LC32F1	4 - 30 VAC/DC, Rectangular 2 holes Bezel
LC33F1	4 - 30 VAC/DC, Round Bezel
LC34F1	4 - 30 VAC/DC, Round 3 holes Bezel
LC35F1	4 - 30 VAC/DC, Cup Mount Bezel
LC36F1	4 - 30 VAC/DC, Stirrup Mount Bezel
LC37F1	4 - 30 VAC/DC, Square Mount Bezel

VIEWS OF DIFFERENT BEZELS



Rectangular Bezel



Rectangular 2 holes Bezel



Round Bezel



Round 3 holes Bezel



Cup Mount Bezel



Stirrup Mount Bezel

Hour Meter Series HM36

- Robust design with high degree of Accuracy and Compact size
- Frequency independent for AC applications
- Indicates operating time in hours and tenths with running indicators
- Totally sealed from Dust and Moisture
- 6 Digit Non-Resettable with automatic recycle to zero
- Wide supply voltage range: 90 - 460V AC, 10 - 80V DC & 110 V DC
- Suitable for Control Panel applications



Cat. No.	30A6B1	30D1B1	30D4B1
Parameters			
Supply Voltage (φ)	90 - 264 / 270 - 460 VAC	10 - 80 VDC	110 VAC
Frequency	50/60 Hz	N A	N A
Over Voltage	N A	96 VDC, 1 min	96 VDC, 1 min
Reverse Polarity Protection	N A	Yes	Yes
Power Consumption (Max.)	1 VA Max	0.25 VA	0.5 VA
Register	6 Digit (3.6mm)		
Read Out	99999.9		
Least Count	1/10 h		
Accuracy	± 0.02% over entire range		
Vibration	10-80Hz with 20g max (SAE J1378)		
Shock	55g @ 9-13ms (SAE J1378)		
Weight (unpacked)	70g		
Operating Temperature	-5° C to +55° C		
Storage Temperature	-20° C to +70° C		
Humidity (Non Condensing)	95% (Rh)		
Mounting	Base/DIN Rail		
Termination	¼" [6.3] Spade Terminal		
Degree of Protection	IP 20 for Terminals, IP 40 for Enclosure		
Approvals	 		



ORDERING INFORMATION

Cat. No.	Description
30A6B1	90 - 264 / 270 - 460 VAC, Hour Meter
30D1B1	10 - 80 VDC, Hour Meter
30D4B1	110 VDC, Hour Meter

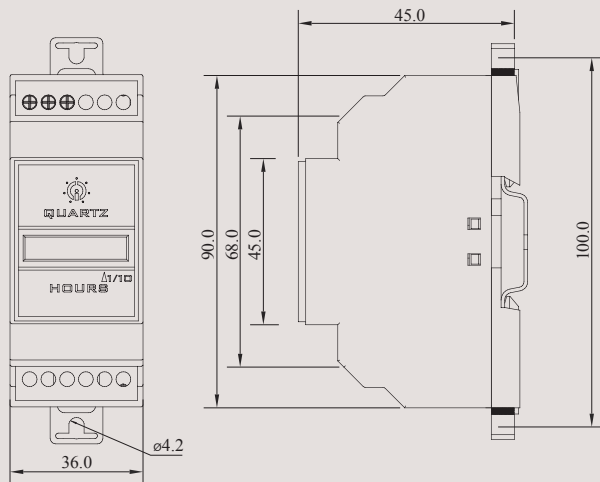
MOUNTING DIMENSIONS (mm)

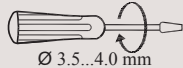

TERMINAL TORQUE & CAPACITY

 Ø 3.5...4.0 mm	Torque - 0.54 N.m (5 Lb.in) Terminal screw - M2.6
	Solid Wire - 1 X 0.2...3.3 mm ²
AWG	1 X 24 to 12

CONNECTION DIAGRAM

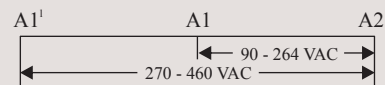

Hour Meter Series HM36

MOUNTING DIMENSION (mm)

SQUARE MOUNT BEZEL (45 X 45 PANEL CUTOUT)

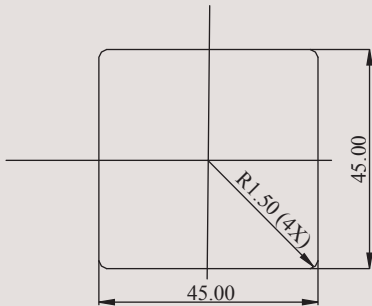

ROUND BEZEL, ROUND 3 HOLES BEZEL, CUP MOUNT BEZEL & STIRRUP MOUNT BEZEL

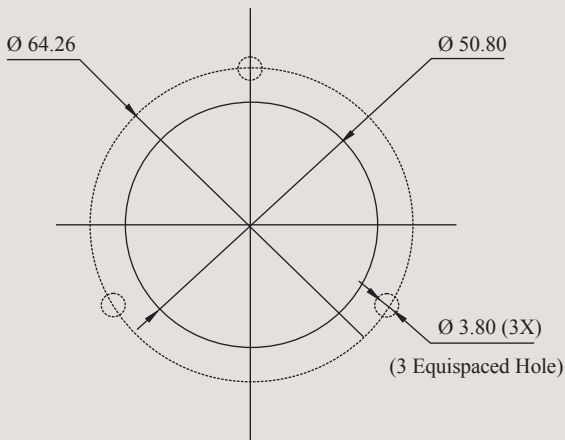

RECTANGULAR BEZEL

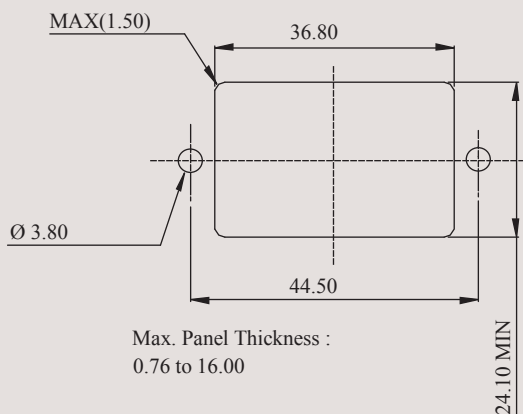

CONNECTION DIAGRAM

FOR: DC SERIES

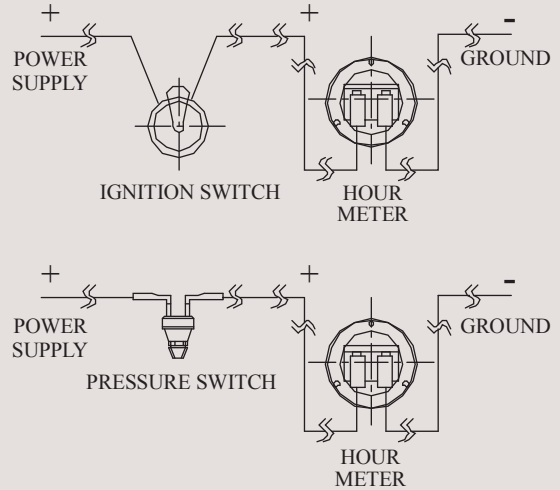

FOR: AC SERIES

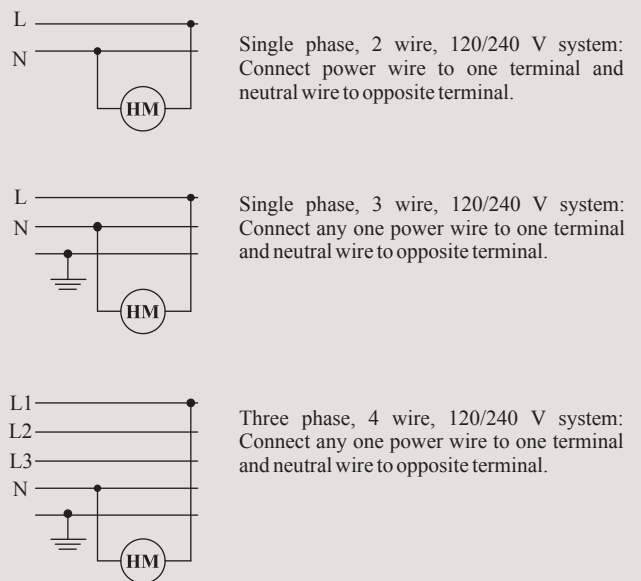

CAUTION

Tighten terminals with flat head screwdriver with tip size 4.3 x 0.6 mm.

Hour Meter Series HM36

VIEWS OF DIFFERENT BEZELS

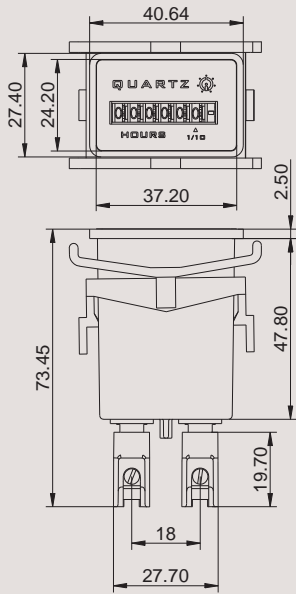

Rectangular Bezel

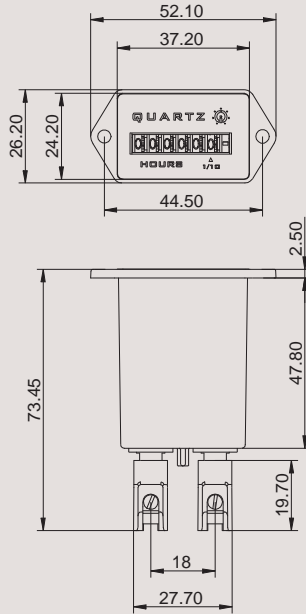

Rectangular 2 holes Bezel

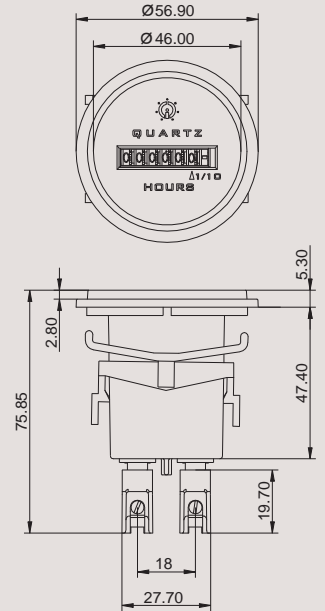

Round Bezel

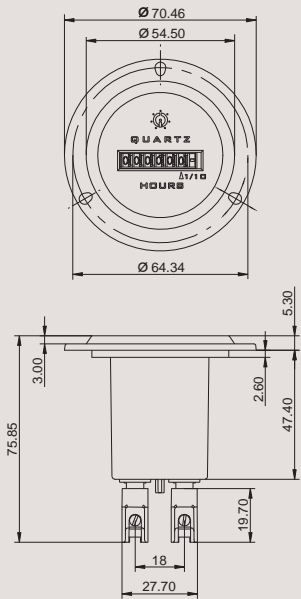

Round 3 holes Bezel

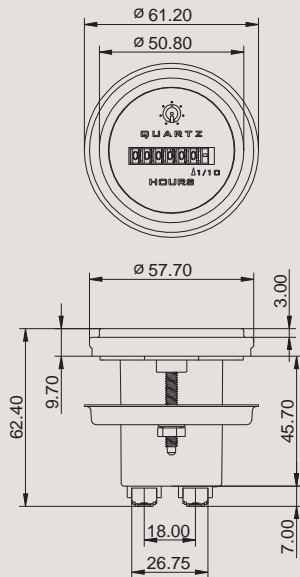

Cup Mount Bezel

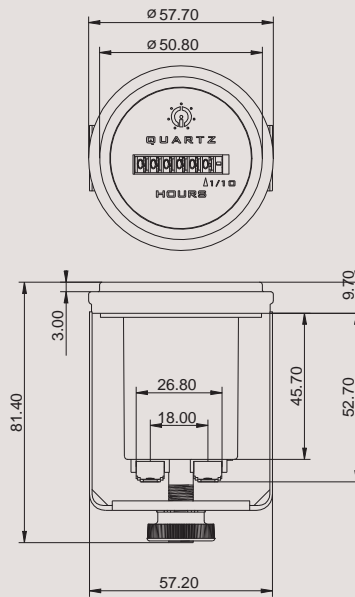

Stirrup Mount Bezel

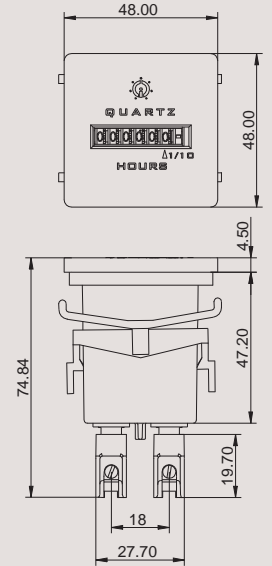

Square Bezel

Dimensions in mm

Digital Hour Meter & Counter

- Compact size with 7-digit Display with 6.5 mm height with Backlit LCD.
- Suitable for both hour meter & Counter application.
- Suitable for panel mounting.



Cat. No.	Z2001N0G1FT00	Z2121N0G1FT00
Parameters		
Supply Voltage (≡)	7 VDC to 60 VDC	90-277V AC/DC
Device Mode Selection	Counter / Hour Meter (Selectable)	
Device Configuration	Using SET & RESET switches & menu driven LCD screens	
Max. Power Consumption (W)	1 W	
Display	7 digit LCD, 6.5 mm Height	
Display Type	Negative Transmissive	
Backlit	Green	
Annunciators	LCD 1.1mm	
Indication Range for Counter	From 9999999 to 9999.999 with prescaler & decimal point selection	
Max. Counter Frequency	40 Hz or Pulse width 12.5ms (min.)	
Counter Accuracy	100%	
Counter Preset	Break-in type Preset with Output ON	
Indication Range for Hour Meter	999:99:99(Hr:Min:sec),99999:99(Hr:Min),9999999(Hr),9999999(Min),9999999(Min)	
Resolution for hour meter	1 sec	
Hour Meter Accuracy	±2sec per Day	
Hour Meter Preset	Recurring type Preset with Output ON	
Reset	Manual(Front/Electrical) / Auto/programmable Timeout Reset/No Reset	
Output Type	Open Drain MOSFET with source connected to common	
Output Rated current	60mA	
Output Over current protection	100mA	
Operating Temperature	- 5° C to +55° C	
Storage Temperature	- 10° C to +60° C	
Humidity (Non Condensing)	5 to 95% Rh (Without condensation)	
Enclosure	UL 94 V0 Plastic, Housing : IP30, Front side : IP40, Terminal : IP20	
Weight (Unpacked)	52g	
Panel Cut-out	22mm X 44.8mm	
Mounting	Flush / Panel Mounting	
Certification		
EMI / EMC		
ESD	IEC 61000-4-2	Ed. 2.0 (2008-12) Level II
Radiated Susceptibility	IEC 61000-4-3	Ed. 3.2 (2010-04) Level III
Electrical Fast Transients (AC & DC Power Ports)	IEC 61000-4-4	Ed. 3.0 (2012-04) Level IV
Electrical Fast Transients (Signal Input)	IEC 61000-4-4	Ed. 3.0 (2012-04) Level III
Electrical Fast Transients (MOSFET output)	IEC 61000-4-4	Ed. 3.0 (2012-04) Level I
Surges (AC & DC Power Ports)	IEC 61000-4-5	Ed. 2.0 (2005-11) Level III
Surge (Signal Input)	IEC 61000-4-5	Ed. 2.0 (2005-11) Level II
Conducted Susceptibility	IEC 61000-4-6	Ed. 3.0 (2008-10) Level III
Voltage Dips (AC)	IEC 61000-4-11	Ed. 2.0 (2004-03) All 7 Levels
Voltage Dips (DC)	IEC 61000-4-29	Ed. 1.0 (2000-08) All 5 Levels
Conducted Emission	CISPR 14-1	Ed. 5.2 (20011-11) Class A
Radiated Emission	CISPR 14-1	Ed. 5.2 (20011-11) Class A
Safety Compliance:		
High Voltage (All Terminal & Enclosure)	IEC 60068-2-2	Ed. 5.0 (2007-07)
Leakage Current	UL 508	Ed. 17 (1999-01) <3.5 mA
Environmental		
Cold Heat	IEC 60068-2-1	Ed. 6.0 (2007-03)
Dry Heat	IEC 60068-2-2	Ed. 5.0 (2007-07)
Vibration	IEC 60068-2-6	Ed. 7.0 (2007-12) 5g
Repetitive Shock	IEC 60068-2-27	Ed. 4.0 (2008-02) 40g, 6ms
Non-Repetitive Shock	IEC 60068-2-27	Ed. 4.0 (2008-02) 30g, 15ms



ORDERING INFORMATION

Cat. No.	Description
Z2001N0G1FT00	7V DC - 60V DC (with MOSFET output)
Z2121N0G1FT00	90-277V AC/DC (with MOSFET output)
Z2221N0G2FT00	85-265 V AC/DC (with Relay output)
Z2301N0G1FT00	9-30 V DC (with dual MOSFET output)

Digital Hour Meter & Counter

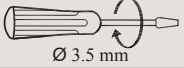

TERMINAL TORQUE & CAPACITY

 Ø 3.5 mm	Torque - 0.40 N.m (3.5 Lb.in) Terminal screw - M2.5
	Solid Wire - 1 X 0.3...2.5 mm ²
AWG	22 to 14

MOUNTING DIMENSIONS (mm)

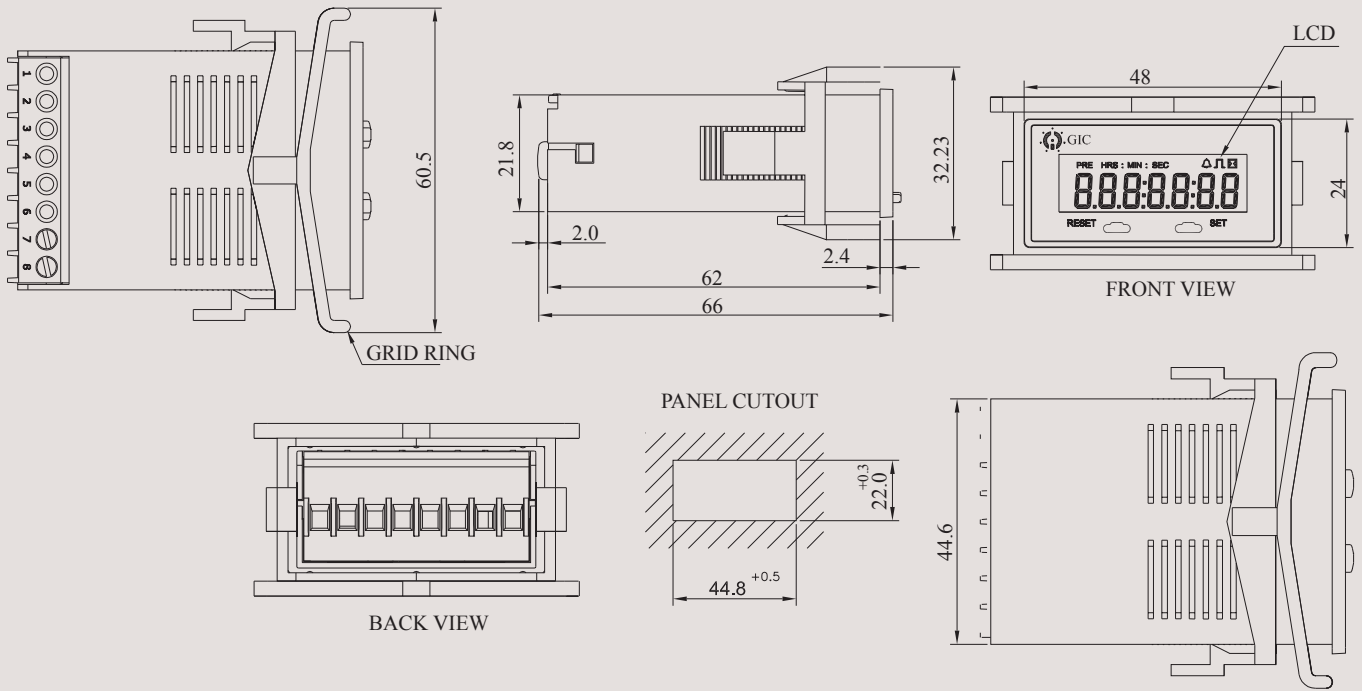

CONNECTION DIAGRAM

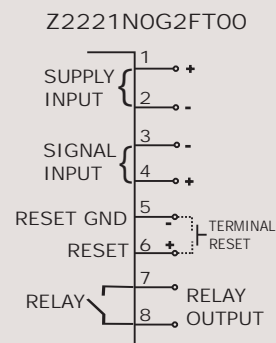
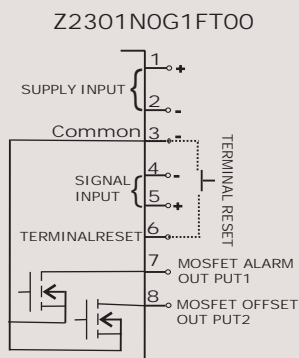
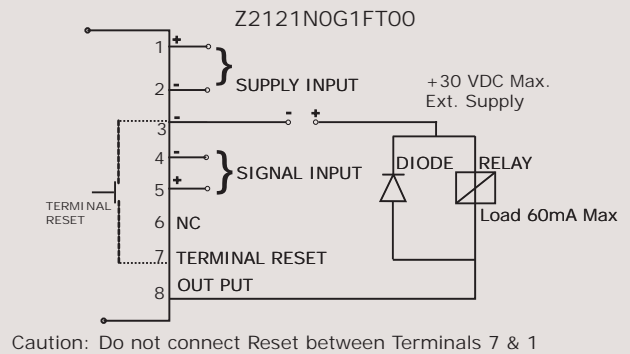
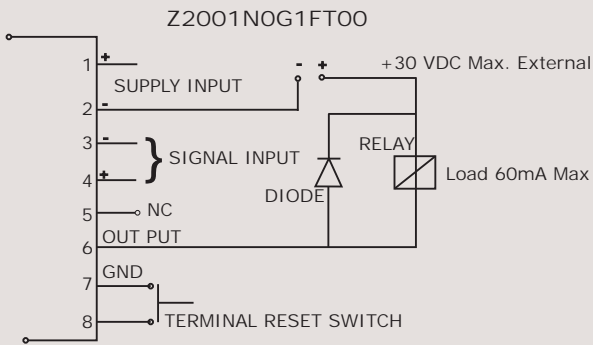

Digital Hour Meter

- 6-digit LCD
- In-built nonvolatile memory (EEPROM) offering exceptional reliability
- Wide range of supply voltage
- Remote reset
- Available in 3 different Bezels
- Low Power Consumption



Cat. No.	Z71FBX	ZJ1FBX	ZH1FBX
Parameters			
Supply Voltage (φ)	85 - 265 VAC	12 - 48 VAC/DC	10 - 80 VDC
Frequency	50/60 Hz	50/60 Hz	N A
Power Consumption (Max.)	0.8 VA	0.4 W	0.6 W
Range	99999.9 h		
Display	6-digit LCD 5mm Height		
Resolution	1/10 h		
Accuracy	± 0.02%		
Memory Retention	100 Years		
Operating Temperature	-10° C to +50° C		
Storage Temperature	-20° C to +65° C		
Humidity	95% (Rh)		
Degree of Protection	IP54 (for front side only)		
Enclosure	UL94-V0		
Terminals	1, 2: Input Supply, 3: Enable 4: Reset		
Panel cut outs	Round Bezel, 24 x 48 Bezel, Screw Mount Bezel		
Mounting	Flush / Panel Mounting		
Certification	 		
Weight (unpacked)	With Round Bezel- 35g, with 24 x 48 Bezel- 29 g, with Screw Mount Bezel- 31 g		
EMI / EMC			
Harmonic Current Emissions	IEC 61000-3-2	Ed. 3.2 (2009-04) Class A	
ESD	IEC 61000-4-2	Ed. 2.0 (2008-12) Level II	
Radiated Susceptibility	IEC 61000-4-3	Ed. 3.2 (2010-04) Level III	
Electrical Fast Transients	IEC 61000-4-4	Ed. 3.0 (2012-04) Level IV	
Surges	IEC 61000-4-5	Ed. 2.0 (2005-11) Level IV	
Conducted Susceptibility	IEC 61000-4-6	Ed. 3.0 (2008-10) Level III	
Voltage Dips & Interruptions (AC)	IEC 61000-4-11	Ed. 2.0 (2004-03) All 7 Levels	
Voltage Dips & Interruptions (DC)	IEC 61000-4-29	Ed. 1.0 (2000-08) All 5 Levels	
Conducted Emission	CISPR 14-1	Ed. 5.2 (2011-11) Class A	
Radiated Emission	CISPR 14-1	Ed. 5.2 (2011-11) Class A	
Environmental			
Cold Heat	IEC 60068-2-1	Ed. 6.0 (2007-03)	
Dry Heat	IEC 60068-2-2	Ed. 5.0 (2007-07)	
Vibration	IEC 60068-2-6	Ed. 7.0 (2007-12) 5g	
Repetitive Shock	IEC 60068-2-27	Ed. 4.0 (2008-02) 40g, 6ms	
Non-Repetitive Shock	IEC 60068-2-27	Ed. 4.0 (2008-02) 30g, 15ms	

ORDERING INFORMATION

Cat. No.	Description
Z71FBX	85-265 VAC model
ZJ1FBX	12-48 VAC/DC model
ZH1FBX	10-80 VDC model
X	A = Round Bezel, B = 24x48 Bezel, C = Screw Mount Bezel

Digital Hour Meter

MOUNTING DIMENSION (mm)

DIGITAL HOUR METER

SCREW MOUNT BEZEL

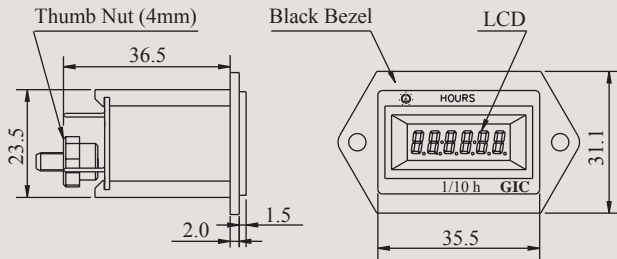

Recommended Panel Cutout :
37.0 (+0.5)mm x 24.6 (+0.5)mm

24X48 BEZEL

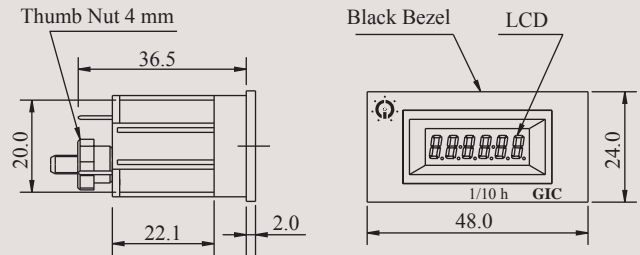

Recommended Panel Cutout :
45.5 (+0.5)mm x 23.0 (+0.5)mm

ROUND BEZEL

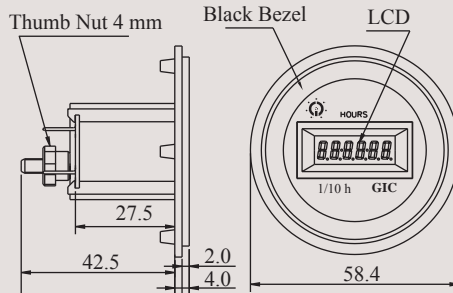

Recommended Panel Cutout :
37.0 (+0.5)mm x 24.6 (+0.5)mm

CONNECTION DIAGRAM

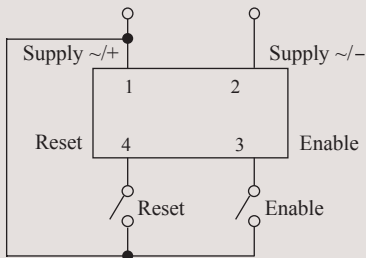

TERMINAL DESCRIPTION

- Pin 1: Supply (~ / +)
- Pin 2: Supply (~ / -)
- Pin 3: Enable
- Pin 4: Reset

DIGITAL HOUR METER

Impulse Counter Series CR 18

- 7-digit Compact Size
- High Accuracy and Reliability
- Requires no lubrication or maintenance
- Ideal where space is limitation
- Mounting options: Panel, PCB



Cat. No.	ED11A	ED11B	ED22D	ED23D	ED24C
Parameters					
Supply Voltage (V)	12 V DC		24 V DC		
Supply Variation	-15% to +10%		±10%		-15% to +10%
Power Consumption (Max.)	1.2 W				
Figure	7 Digit, Black, 4.0 mm Height				
Maximum Range	99,99,999				
Operating Life	10,000,000 counts minimum				
Speed (Counts / Minute)	600 (50ms-ON / 50ms-OFF)		1200 (25ms-ON / 25ms-OFF)		600 (50ms-ON / 50ms-OFF)
Pulse Width (minimum)	50 ms		25 ms		50 ms
Connection	Lead wire with connector		Terminal PIN (Pitch : 10 mm)	Terminal PIN (Pitch : 3.80 mm)	Lead Wire
	#39-01-4031 #39-00-0039	# 03-09-2022 #02-09-2116			
Panel Cutout	N.A				1.20'(30.48) x 0.96'(24.38) Panel thickness - 0.04'(1.0) to 0.08'(2.0)
Protection for Housing	Tamper Proof housing		N.A		
Weight (unpacked)	142 g				
Operating Temperature	-5° C to +40° C (Non-Freezing)				
Humidity (Non Condensing)	45 to 85% (Rh)				
Display	0.12'(3.0) x 0.06'(1.6) - White & black background				
Continuous Energizing	Permissible				
Counting Method	One pulse - One count (energizing - ½ count, unenergized - ½ count)				
Reset	None				
Shock test	Endurance: 300 m/s ² (30g) XYZ 5 times each direction, Total : 3, Mismovement : 50 m/s ² (5g) XYZ 4 times each direction, Total : 24.				
Vibrations test	Endurance: 16.7 Hz, Width : 4mm ; XYZ each direction for 1 hour Mismovement : 10~55 Hz, Width : 0.5mm ; XYZ each direction for 10 mins				
Type of Mounting	Behind the panel (Screw mount)		PCB mount (Straight)	PCB mou(Right angle)	Panel (Snap-in type)
Degree of Protection	IP 30				
Construction	Cover : Plastic (Noryl UL94V-1), Black				
Approvals					

ORDERING INFORMATION

Cat. No.	Description
ED11A	12 V DC, Behind the panel (Screw mount)
ED11B	12 V DC, Behind the Panel With out Seal Hole (Screw mount)
ED22D	24 V DC, PCB mount (Straight)
ED23D	24 V DC, PCB mount (Right angle)
ED24C	24 V DC, Panel (Snap-in type)

VIEWS OF DIFFERENT BEZELS



Behind the panel (Screw mount)



Housing Behind Panel with
Out Seal Hole (Screw mount)



PCB mount (Straight)



PCB mount (Right angle)



Panel (Snap-in type)

Impulse Counter Series CR 18

MOUNTING DIMENSION (mm)

BEHIND THE PANEL (SCREW MOUNT):

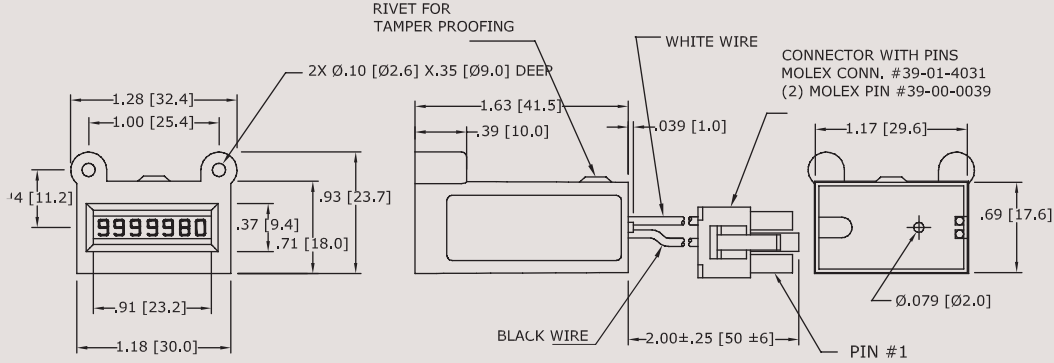

BEHIND THE PANEL (SCREW MOUNT):

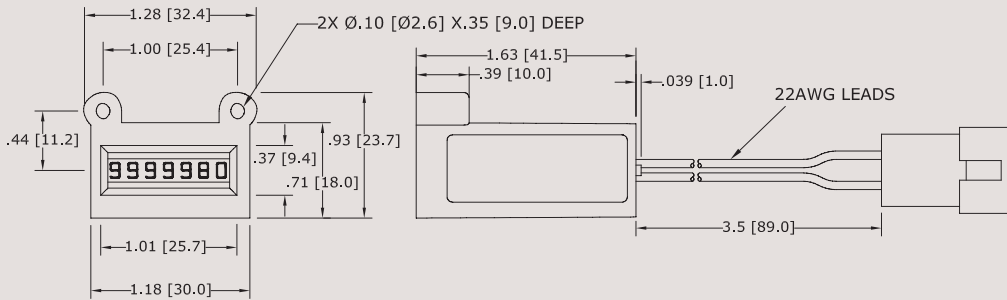

PCB MOUNT(STRAIGHT):

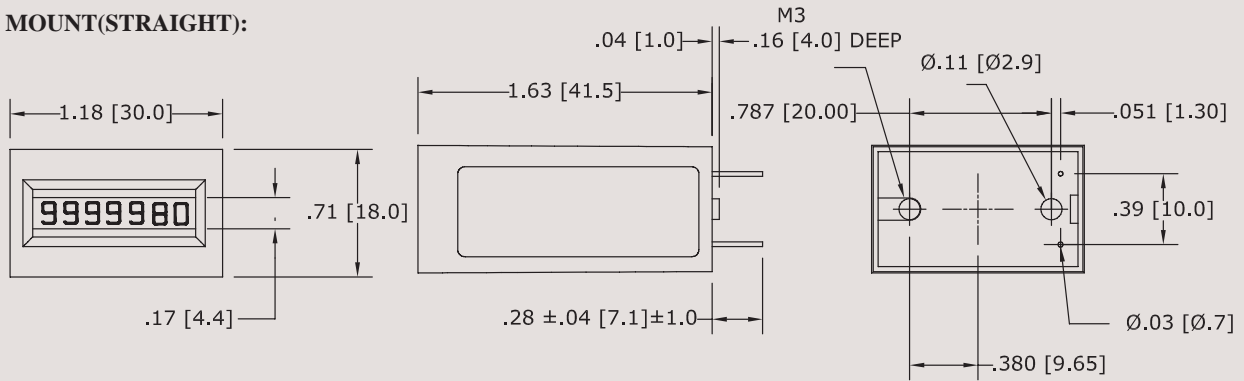

PCB MOUNT(RIGHT ANGLE):

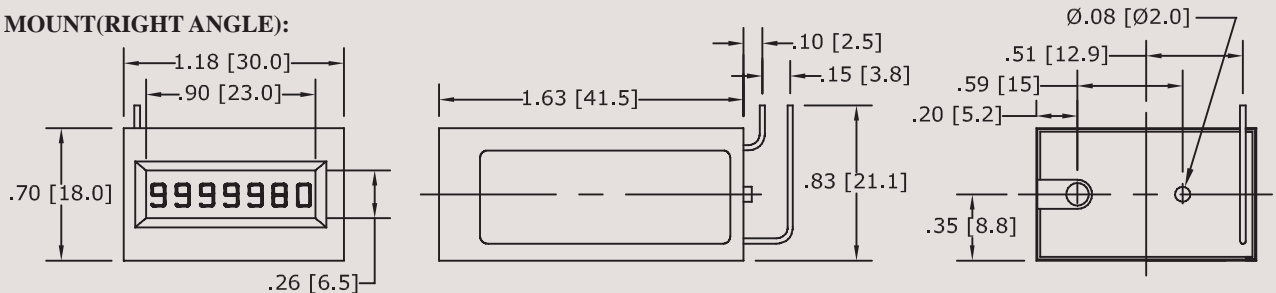

PANEL (SNAP-IN TYPE):

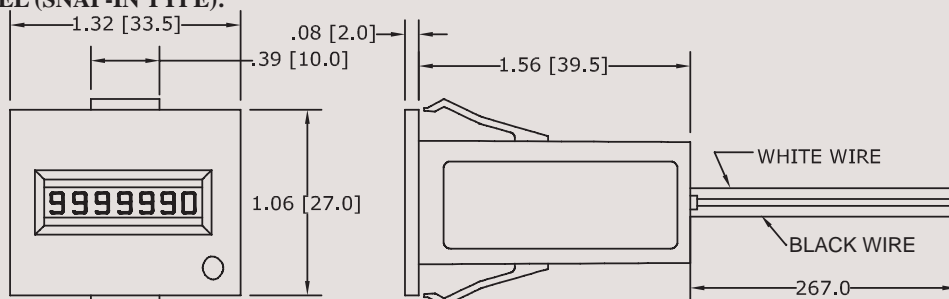

Impulse Counter Series CR 26

- 6-digit Compact and Robust Design
- Push-button quick reset
- High Accuracy and Reliability
- Requires no lubrication or maintenance
- Optional locking for reset button
- Ideal where space is limitation
- Three mounting options: Bail, Panel, Base



Cat. No.	SD21A-385	SD31A-385	SA41A-356	SA51A-356
Parameters				
Supply Voltage (φ)	12 VDC	24 VDC	115 VAC	230 VAC
Supply Variation	+10% to -15% (of φ)			
Power Consumption (Max.)	2 W		3 W	
Figure	6 Digit, White on Black, (4.0 mm) Height			
Maximum Range	9,99,999			
Operating Life	Beyond 100 million counts			
Speed	10 Hz Maximum (600 Counts / Minute)			
Pulse Width	50 ms minimum			
Counting Method	One Pulse - One count (energizing - 1/2 count, de-energized - 1/2 count)			
Continuous Energizing	Permissible			
Reset	Manual push button Reset (Reset button can be locked or sealed to avoid accidental reset)			
Weight (unpacked)	142 g			
Operating Temperature	-5° C to +50° C (Non-Freezing)			
Humidity (Non Condensing)	45 to 85% (Rh)			
Termination	22 AWG, 105° C wire leads, 254 mm long / 2 way Terminal Strip			
Type of Mounting	Panel, Bail & Base			
Degree of Protection	IP 30			
Certification				
Applications	Ideal for use in - Machine tools, Business Machines, Test Instruments, Amusement Instruments and Measuring devices			

Note: Do not push reset button during change over.

ORDERING INFORMATION

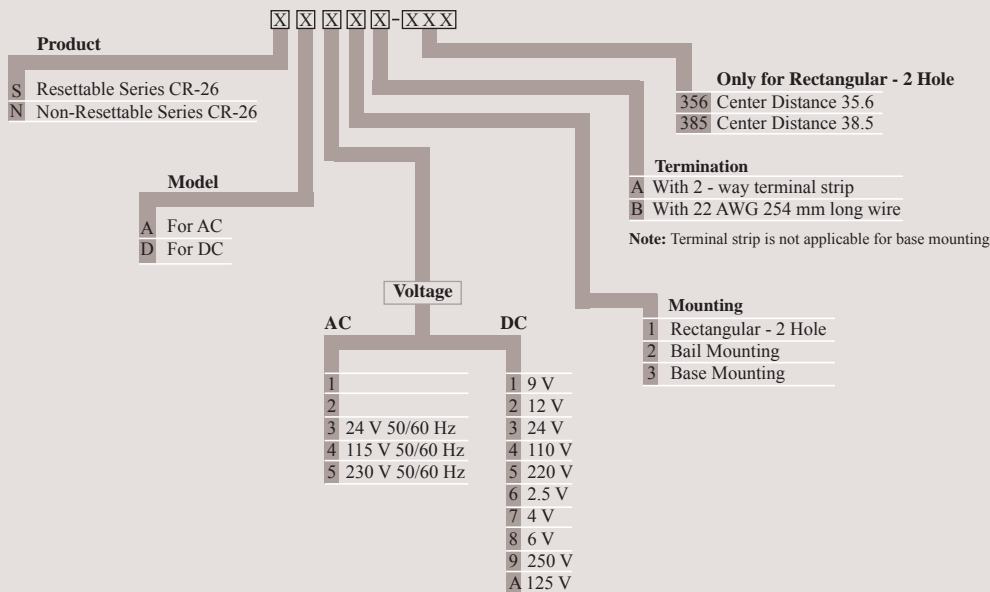

Note: Other voltages will be made available upon request.

Impulse Counter Series CR 26 (4-Digit)

- 4-digit Compact and Robust Design
- Push-button quick reset
- High Accuracy and Reliability
- Requires no lubrication or maintenance
- Optional locking for reset button
- Ideal where space is limitation
- Three mounting options: Bail, Panel, Base



Cat. No.	4SD21A-356	4SD31A-356	4SA41A-356	4SA51A-356
Parameters				
Supply Voltage (φ)	12 VDC	24 VDC	115 VAC	230 VAC
Supply Variation	+10% to -15% (of φ)			
Power Consumption (Max.)	2 W		3 W	
Figure	4 Digit, White on Black, (4.0 mm) Height			
Maximum Range	9999			
Operating Life	Beyond 100 million counts			
Speed	10 Hz Maximum (600 Counts / Minute)			
Pulse Width	50 ms minimum			
Counting Method	One Pulse - One count (energizing - 1/2 count, de-energized - 1/2 count)			
Continuous Energizing	Permissible			
Reset	Manual push button Reset (Reset button can be locked or sealed to avoid accidental reset)			
Weight (unpacked)	113 g			
Operating Temperature	-5° C to +50° C (Non-Freezing)			
Humidity (Non Condensing)	45 to 85% (Rh)			
Termination	22 AWG, 105° C wire leads, 254 mm long / 2 way Terminal Strip			
Type of Mounting	Panel, Bail & Base			
Degree of Protection	IP 30			
Certification				
Applications	Ideal for use in - Machine tools, Business Machines, Test Instruments, Amusement Instruments and Measuring devices			

Note: Do not push reset button during change over.

ORDERING INFORMATION

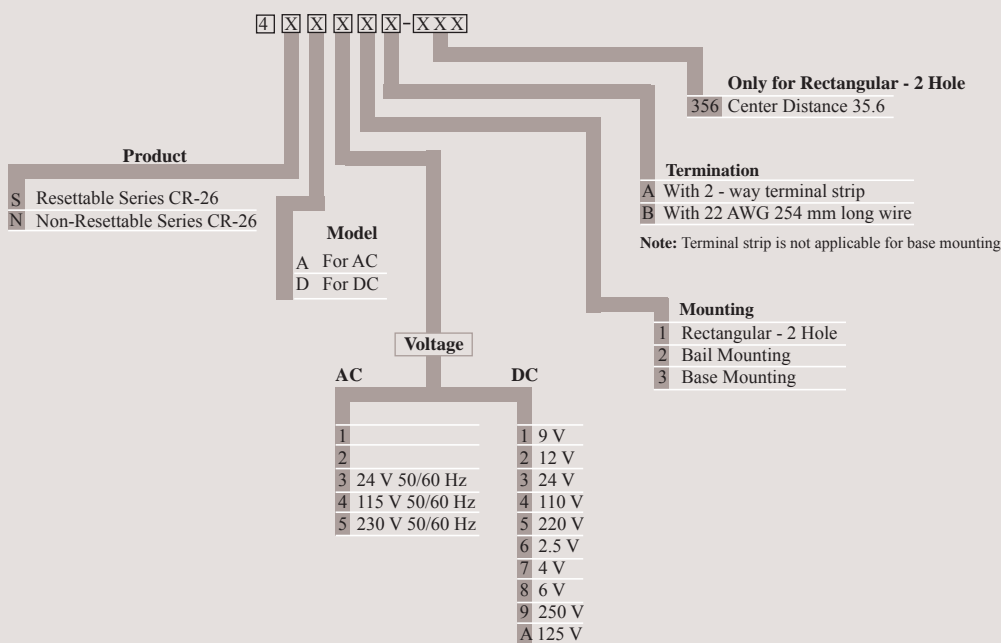



Note: Other voltages will be made available upon request.

Impulse Counter Series CR 36

- Compact Size & Robust Design
- 7 Digit, Non-Resettable
- High Degree of Accuracy & Reliability
- Wide Temperature range
- Shock & Vibration Proof



Cat. No.	QD11A	QD22A
Parameters		
Supply Voltage (±)	12 VDC	24 VDC
Supply Variation	-15% to +10%	
Power Consumption (Max.)	0.25 VA	
Figure	7 Digit, White on Black, (3.6mm) High	
Maximum Range	9999999	
Speed	10 Hz Maximum (600 counts/minute)	
Pulse Width	50 ms. minimum	
Counting Method	One Pulse - One Count (energizing - ½ count, de-energizing - ½ count)	
Weight	45 gm	
Operating Temperature	-5°C to +50°C	
Humidity (Non Condensing)	45% to 85% (Rh)	
Mounting	Panel	
Degree of Protection	NEMA 4X (IP 65)	
Certification	 	

ORDERING INFORMATION

Cat. No.	Description
QD11A	12 VDC, Rectangular Bezel
QD21A	24 VDC, Rectangular Bezel
QD12A	12 VDC, Rectangular 2 Hole Bezel
QD22A	24 VDC, Rectangular 2 Hole Bezel
QD23A	24 VDC, Round Bezel

Digital Counters

- 6-digit LCD
- In-built nonvolatile memory (EEPROM) offering exceptional reliability
- Wide range of supply voltage
- Remote reset
- Available in 3 different shaped Bezels
- Low Power Consumption



Cat. No.	Z72FBX	ZJ2FBX	ZH2FBX
Parameters			
Supply Voltage (V)	85 - 265 VAC	12 - 48 VAC/DC	10 - 80 VDC
Frequency	50/60 Hz	50/60 Hz	N A
Power Consumption (Max.)	0.8 VA	0.4 W	0.6 W
Counting frequency	10Hz	10Hz	30Hz
Maximum Range	999999		
Display	Large 6-Digit display, easy to read		
Resolution	1 Count		
Reset	Electrical		
Memory Retention	100 Years		
Operating Temperature	- 10° C to +50° C		
Storage Temperature	- 20° C to +65° C		
Accuracy	± 1 Count		
Humidity (Non Condensing)	95% (Rh)		
Degree of Protection	IP54		
Enclosure	UL94-V0		
Terminals	1 & 2: Input Supply, 3: Count 4: Reset		
Panel cut outs	Round Bezel, 24 x 48 Bezel, Screw Mount Bezel		
Mounting	Flush/ Panel Mounting		
Certification			
Weight (unpacked)	With Round Bezel - 35g, with 24 x 48 Bezel - 29 g, with Screw Mount Bezel - 31 g		
EMI / EMC			
Harmonic Current Emissions	IEC 61000-3-2	Ed. 3.2 (2009-04) Class A	
ESD	IEC 61000-4-2	Ed. 2.0 (2008-12) Level II	
Radiated Susceptibility	IEC 61000-4-3	Ed. 3.2 (2010-04) Level III	
Electrical Fast Transients	IEC 61000-4-4	Ed. 3.0 (2012-04) Level IV	
Surges	IEC 61000-4-5	Ed. 2.0 (2005-11) Level IV	
Conducted Susceptibility	IEC 61000-4-6	Ed. 3.0 (2008-10) Level III	
Voltage Dips & Interruptions (AC)	IEC 61000-4-11	Ed. 2.0 (2004-03) All 7 Levels	
Conducted Emission	CISPR 14-1	Ed. 5.2 (2011-11) Class A	
Radiated Emission	CISPR 14-1	Ed. 5.2 (2011-11) Class A	
Environmental			
Cold Heat	IEC 60068-2-1	Ed. 6.0 (2007-03)	
Dry Heat	IEC 60068-2-2	Ed. 5.0 (2007-07)	
Vibration	IEC 60068-2-6	Ed. 7.0 (2007-12) 5g	
Repetitive Shock	IEC 60068-2-27	Ed. 4.0 (2008-02) 40g, 6ms	
Non-Repetitive Shock	IEC 60068-2-27	Ed. 4.0 (2008-02) 30g, 15ms	

ORDERING INFORMATION

Cat. No.	Description
Z72FBX	85-265 VAC model
ZJ2FBX	12-48V AC/DC model
ZH2FBX	10-80V DC model
X	A=Round Bezel, B=24x48 Bezel, C=Screw Mount Bezel

Impulse Counter Series CR 26

MOUNTING DIMENSION (mm)

IMPULSE COUNTER CR 26

Resettable Counter
SXXXA

	A=With terminal strip	B=With 22 AWG 254 mm long wire	Panel cutout dimension
1. Panel Mount - 6 Figure SXXX-385			
2. Panel Mount - 6 Figure SXXX-356			
3. Bail Mount - 6 Figure			
4. Base Mount - 6 Figure			
5. Optional locking for reset button			To avoid the tampering with the reset button you can seal the counter as shown in the above figure

NON RESETTABLE COUNTER- NXXXXA

A = Counter with Terminal Strip(not applicable for Base Mounting)
B = Counter with Wire (22 AWG 254 mm Long)

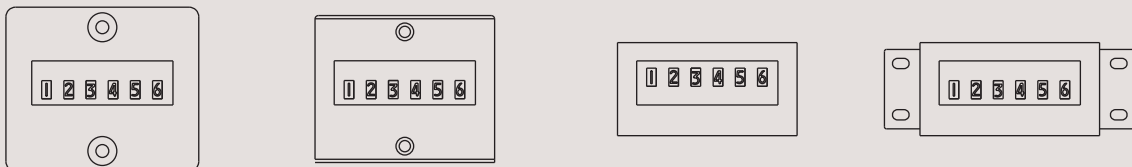

Note: For Non Resettable Counters, reset arm lever will not be present and all other details will be common with resettable counter.

Impulse Counter Series CR 26 (4-Digit)

MOUNTING DIMENSION (mm)

IMPULSE COUNTER CR 26 (4 FIG)

Resettable Counter

4XXXXA

	A=With terminal strip	B=With 22 AWG 254 mm long wire	Panel cutout dimension
<p>1. Panel Mount - 4 Figure 4XXXXX-356</p>			
<p>2. Bail Mount - 4 Figure 4XXXXX</p>			
<p>3. Base Mount - 4 Figure 4XXXXX</p>			
<p>4. Optional locking for reset button</p> <p>To avoid the tampering with the reset button you can seal the counter as shown in the above figure</p>			
<p>NON RESETTABLE COUNTER- NXXXXA</p> <p>A = Counter with Terminal Strip(not applicable for Base Mounting) B = Counter with Wire (22 AWG 254 mm Long)</p>			
<p>Note: For Non Resettable Counters, reset arm lever will not be present and all other details will be common with resettable counter.</p>			

MOUNTING DIMENSIONS (mm)

IMPULSE COUNTER CR 36

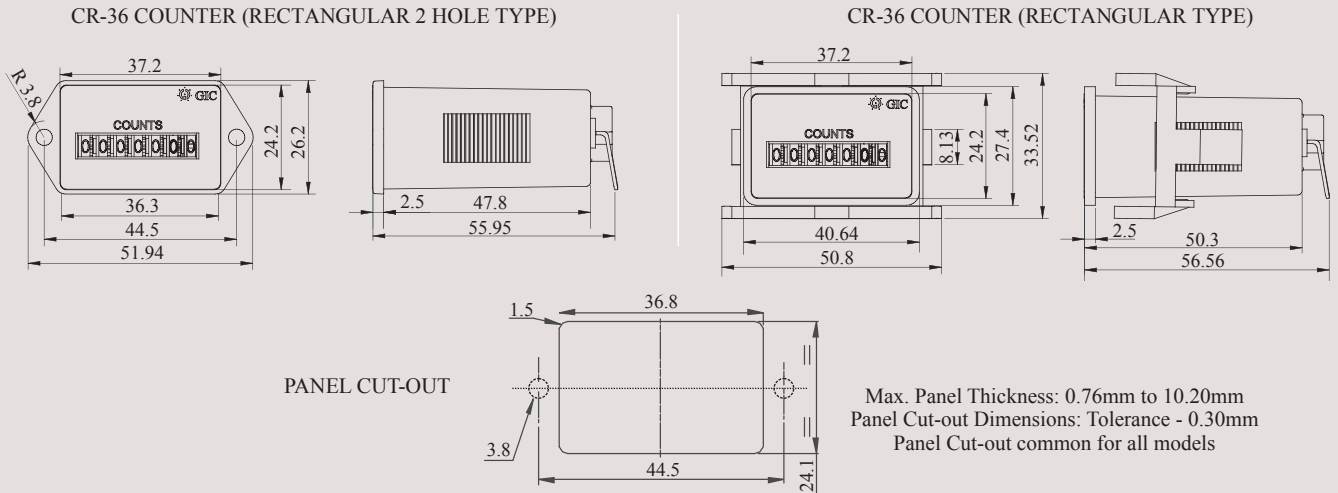

DIGITAL COUNTER

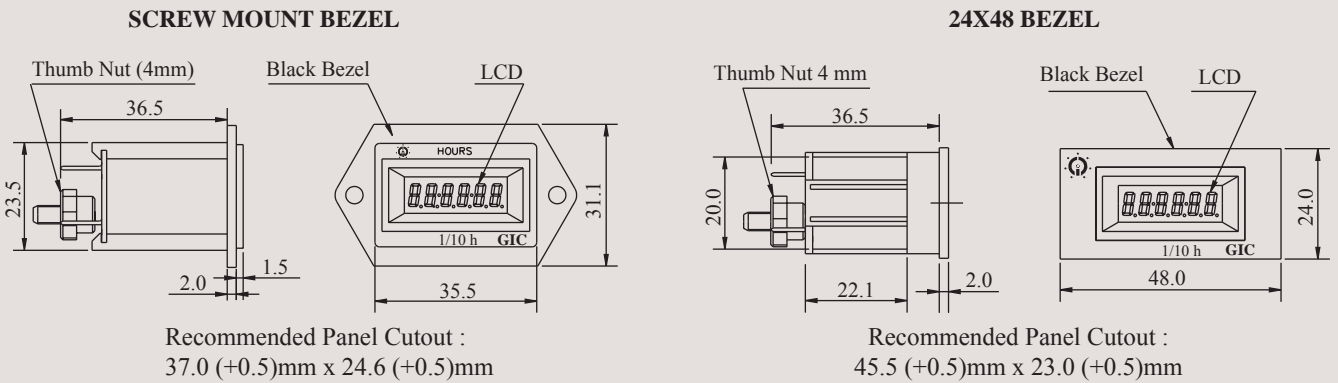

ROUND BEZEL

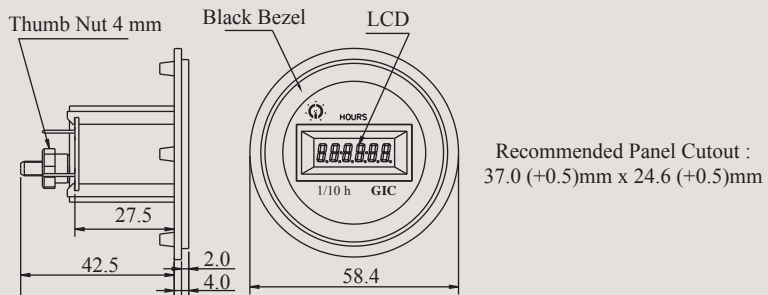

CONNECTION DIAGRAM

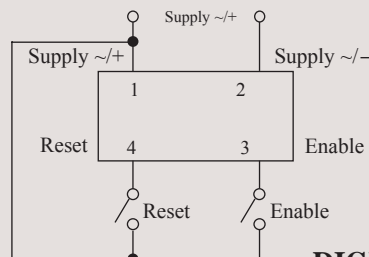

TERMINAL DESCRIPTION

- Pin 1: Supply (~ / +)
- Pin 2: Supply (~ / -)
- Pin 3: Enable
- Pin 4: Reset

DIGITAL COUNTER

CONTROLLERS

Programmable Logic Controllers



Smart Relay *Genie™ - M*

GSM Controller

Smart Relay Genie™ - Nx

- Supports upto 48 I/Os (32 Digital Inputs & 16 Digital Outputs)
- 250 lines of ladder programming
- 16 soft text messages, Time Switches, Compare Counters, Timers, Counters & 12 Analog functions, 4 Hour Meters
- DST Feature Available
- Backlit LCD Screen for display & modification of pre-selected parameters of functional blocks, viewing I/O status and programming on the device
- PC software for programming, online & offline simulation, documentation & printing
- Designed for use in automation for commercial & Industrial sectors





Cat. No.	G7DDT10	G8DDT10	
Parameters			
Supply Voltage (⌀)	110 - 240 VAC	12 - 24 VDC	
Supply Variation	-20% to +10% (of ⌀)		
Frequency	50/60 Hz		
Power Consumption	5W		
Digital Input	8	6	
Analog Input	N A	2 (Can be used as Digital Inputs)	
Digital Input Range	(0 - 40 VAC) OFF, (80 - 265 VAC) ON	(0 - 4 VDC) OFF, (8 - 26.4 VDC) ON	
Analog Input Range	N A	0 to 10 VDC	
Digital Output	Relay Output	4 'NO'	
	Contact Rating	8A @ 240 VAC / 5A @ 30 VDC (Resistive)	
	Electrical Life	10 ⁵	
Utilization Category	AC - 15	Rated Voltage (Ue): 120/240 V, Rated Current (Ie): 3.0/1.5 A	
	DC - 13	Rated Voltage (Ue): 24/125/250 V, Rated Current (Ie): 2.0/0.22/0.1 A	
I/O Extensions (Max.)	3		
Power Reserve (For Clock Only)	7 yrs. (at -10°C to 55°C)		
Modbus Communication	Yes (RTU) (Slave)		
DST	Settable		
Lines for Ladder Programming	250		
Function Blocks	Timers	16 (ON Delay, Interval, Cyclic ON-OFF, OFF Delay)	
	Counters	16 (Up / Down, Retentive selectable)	
	Time Switches	16 (Weekly / Daily)	
	Compare Counters	16	
	Analog Functions	N A	12
	Soft Text Messages	16 (Priority Driven)	
	Auxiliary Relays	64	
Operating Temperature	-10° C To + 55° C		
	Storage Temperature -25° C To + 70° C		
Humidity (Non Condensing)	95% (Rh)		
Enclosure	Flame Retardant UL 94-V0		
Dimension (W x H x D) (in mm)	72 X 90 X 65		
Weight (unpacked) Approx.	230 g		
Mounting	Base / DIN Rail		
Degree of Protection	IP 20 for Terminals, IP 40 for Enclosure		
Certification	  		
EMI / EMC			
Harmonic Current Emissions	IEC 61000-3-2	Ed. 3.2 (2009-04) Class A	
ESD	IEC 61000-4-2	Ed. 2.0 (2008-12) Level II	
Radiated Susceptibility	IEC 61000-4-3	Ed. 3.2 (2010-04) Level III	
Electrical Fast Transients	IEC 61000-4-4	Ed. 3.0 (2012-04) Level IV	
Surges	IEC 61000-4-5	Ed. 2.0 (2005-11) Level IV	
Conducted Susceptibility	IEC 61000-4-6	Ed. 3.0 (2008-10) Level III	
Voltage Dips & Interruptions (AC)	IEC 61000-4-11	Ed. 2.0 (2004-03) All 7 Levels	
Voltage Dips & Interruptions (DC)	IEC 61000-4-29	Ed. 1.0 (2000-08) All 5 Levels	
Conducted Emission	CISPR 14-1	Ed. 5.2 (20011-11) Class A	
Radiated Emission	CISPR 14-1	Ed. 5.2 (20011-11) Class A	
Environmental			
Cold Heat	IEC 60068-2-1	Ed. 6.0 (2007-03)	
Dry Heat	IEC 60068-2-2	Ed. 5.0 (2007-07)	
Vibration	IEC 60068-2-6	Ed. 7.0 (2007-12) 5g	
Repetitive Shock	IEC 60068-2-27	Ed. 4.0 (2008-02) 40g, 6ms	
Non-Repetitive Shock	IEC 60068-2-27	Ed. 4.0 (2008-02) 30g, 15ms	

ORDERING INFORMATION

Cat. No.	Description
G7DDT10	110 - 240 VAC, Genie Nx Base Module
G7DDT10B	110 - 240 VAC, Genie Nx Base Module, Without LCD Display
G8DDT10	12 - 24 VDC, Genie Nx Base Module
G8DDT10B	12 - 24 VDC, Genie Nx Base Module, Without LCD Display
G7DDT10E	110 - 240 VAC, Genie Nx Extension Module
G8DDT10E	12 - 24 VDC, Genie Nx Extension Module
GFDNN3M	Memory Card
GFDNN2S	RS 232 Serial Communication Cable
GFDNN1	USB Cable
GNXNN1/GNXNN2	Genie Nx Software supplied on CD-ROM compatible with Windows 98, 2000, XP, VISTA & Windows 7.



Cat. No.	G7XDTR4	G8XDTR4
Parameters		
Supply Voltage (☉)	110 - 240 VAC	12 - 24 VDC
Input	TTL Level	
Output	RS 485 Protocol (Two wires, D +, D -)	
Number of Nodes	32 Standard unit loads	
Isolation voltage	2000 Vrms	
Baud Rate	300, 600, 1200, 2400, 4800, 9600	
Operating Temperature	-10°C to + 55°C	
Storage Temperature	-20°C to + 70°C	
Modbus Communication	Yes (RTU) (Slave)	
LED Indications	Red LED's for Tx & Rx. Green LED for Power indication.	
Certification	 	
Weight (unpacked)	80 g	84 g

ORDERING INFORMATION

Cat. No.	Description
G7XDTR4	110 - 240 VAC, RS 485 Communication Module
G8XDTR4	12 - 24 VDC, RS 485 Communication Module

MOUNTING DIMENSION (mm)

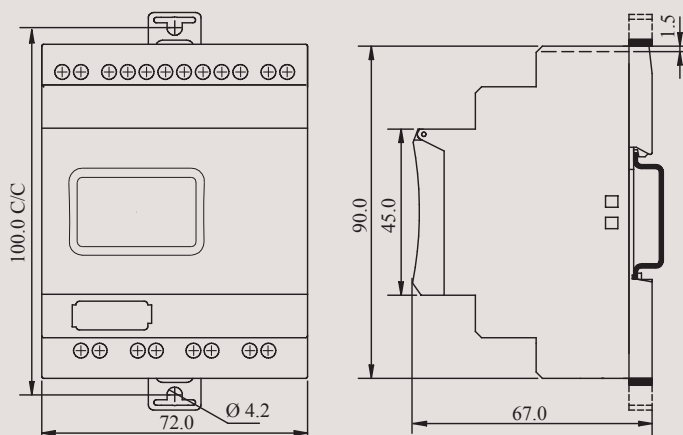

G7DDT10, G7DDT10B, G8DDT10, G8DDT10B, G7DDT10E, G8DDT10E

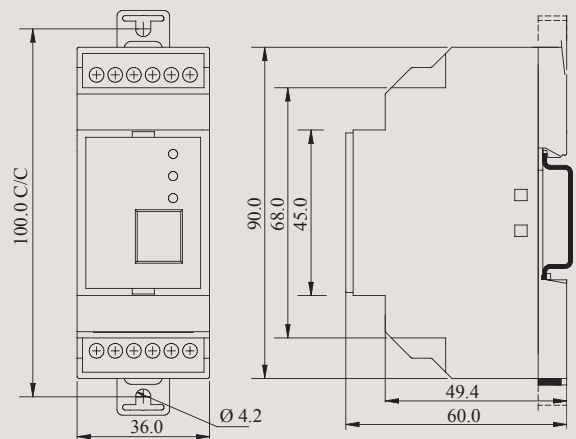

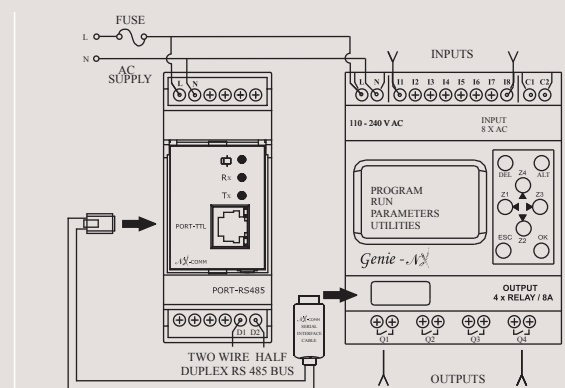
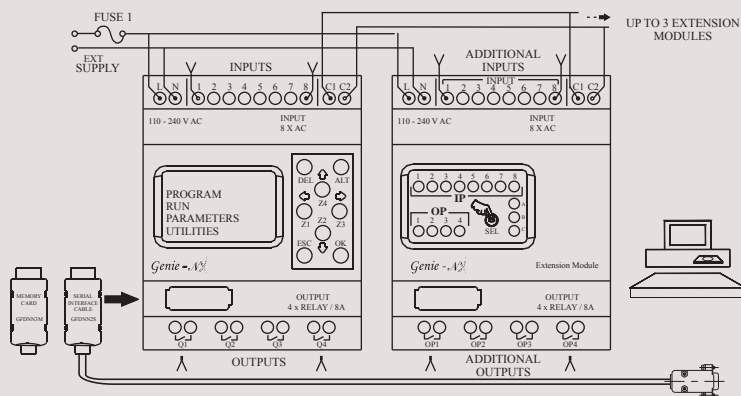

G7XDTR4, G8XDTR4

CONNECTION DIAGRAM

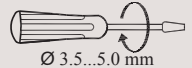

TERMINAL TORQUE & CAPACITY

 Ø 3.5...5.0 mm	Torque - 1.1 N.m (10 Lb.in) Terminal screw - M3.5
	Solid Wire - 2 X 0.2...2.5 mm ²
AWG	1 X 24 to 10



FEATURES

Programming:

Programming can be carried out independently using the keys on the Genie-NX base module with the help of ladder diagram or on a PC, using "G-Soft NX." software.

LCD Backlighting:

Backlight of the LCD display is present for a minimum 15 seconds whenever the device is powered ON or a key is pressed on the base module. The backlight can also be configured to be permanently ON or permanently OFF by configuring the "Device Utilities" option in the device menu or by using the G-Soft NX application software.

Memory Card:

Genie-NX has a Program Transfer feature, which allows programs to be transferred or copied into another Genie-NX with the help of memory card. This feature enables quick copy of the programs without the use of a laptop or a PC.

I/O Extensions:

User can connect a maximum of 3 Extension Modules to the Genie-NX base module & each Extension Module has 8 inputs and 4 outputs, so we can expand up to 48 I/O extensions if necessary via the Genie-NX. Expansions are made in daisy chain fashion.

Communication Module:

A module for communication on the Modbus network is available, which is called "NX-Comm" to facilitate communication of the logic relay over a 2 wire half duplex RS 485 link. Modules are powered by 110- 240 VAC or 12- 24 VDC power supplies. The base module can be connected to this communication interface by means of the cable and the communication takes place via the NX-Comm. on the RS 485 link.

APPLICATIONS

For Industry:

- Printing and Packaging machines
- Ancillary equipments in textile, plastic.
- Material handling equipments, conveyor systems.
- Interlocking units in distributed control systems.

For Commercial/ Building Sector:

- Automation of barriers
- Automation of compressors and pumps for air conditioning requirements
- Automation of lights

GSM Controller

- Ideal for ON /OFF Switching of equipment remotely using Mobile Handsets
- Suitable for both 1 Phase and 3 Phase installations
- Flexible antenna positioning to get proper signal strength
- SMS alerts for ON/OFF status, Power fail, SIM balance, delivery of error/recovery messages from protection devices
- Switching enabled by number of missed rings or sending SMS to the device
- Option of Auto Mode for automatic operation,
- Daily time switch mode for routine program and timer mode for specific duration of operation



Cat. No.

26A11AV

Parameters			
Supply Voltage (⊕)	160V AC to 500V AC (For Single Phase : Connect Live to R or Y & Neutral to B & COM terminal of Controller)		
Frequency	50-60 Hz		
Power Consumption (Max.)	8 VA (max) at product ON but in idle condition / 50 VA when call is being made		
Initiate Time / Reset Time	35 Sec / 1 Sec Max. (can be lower during call)		
Contact Ratings	Terminal 15 & 16 – NC ,Terminal 25 & 28 – NO, 5A @ 250V AC / 30V DC (Res)		
FUNCTIONAL CHARACTERISTICS :			
LED Indications	LED	INDICATION	DEVICE STATUS
	ON (Green)	ON Blinking @ 500 m Sec	Master number configured. GSM modem in factory default mode
	CFG (Red)	Blinking @ 500 m Sec	GSM modem in configuration mode
	N/W (Green)	Flash every 800 m sec Flash every 3 sec	Not registered with N/W Registered with N/W
	I1 & I2 (Yellow)	Both ON Either or both OFF	Load ON Load OFF
	Tx/Rx (Green)	Communication between CPU & Modem	
GSM Modem	Quad band 850MHz,900MHz / 1800MHz,1900MHz		
Operating Temperature	0° C to +60° C		
Storage Temperature	-20° C to +70° C		
Humidity (Non Condensing)	95% (Rh)		
Enclosure	IP 30 for Housing & front Facial and IP 20 for Terminals		
Dimension (W x H x D) (in mm)	72 X 90.5 X 65		
Weight (unpacked)	160 g		
Mounting	DIN rail / Base		
Certification			
Degree of Protection	IP 20 for Terminals, IP 30 for Enclosure		
EMI / EMC			
Harmonic Current Emissions	IEC 61000-3-2	Ed. 3.2 (2009-04) Class A	
ESD	IEC 61000-4-2	Ed. 2.0 (2008-12) Level II	
Radiated Susceptibility	IEC 61000-4-3	Ed. 3.2 (2010-04) Level III	
Electrical Fast Transients	IEC 61000-4-4	Ed. 3.0 (2012-04) Level IV	
Surges	IEC 61000-4-5	Ed. 2.0 (2005-11) Level IV	
Conducted Susceptibility	IEC 61000-4-6	Ed. 3.0 (2008-10) Level III	
Voltage Dips & Interruptions (AC)	IEC 61000-4-11	Ed. 2.0 (2004-03) All 7 Levels	
Voltage Dips & Interruptions (DC)	IEC 61000-4-29	Ed. 1.0 (2000-08) All 5 Levels	
Conducted Emission	CISPR 14-1	Ed. 5.2 (20011-11) Class B	
Radiated Emission	CISPR 14-1	Ed. 5.2 (20011-11) Class B	
Environmental			
Cold Heat	IEC 60068-2-1	Ed. 6.0 (2007-03)	
Dry Heat	IEC 60068-2-2	Ed. 5.0 (2007-07)	
Vibration	IEC 60068-2-6	Ed. 7.0 (2007-12) 5g	
Repetitive Shock	IEC 60068-2-27	Ed. 4.0 (2008-02) 40g, 6ms	
Non-Repetitive Shock	IEC 60068-2-27	Ed. 4.0 (2008-02) 30g, 15ms	

ORDERING INFORMATION

Cat. No.	Description
26A11AV	160 - 500 VAC, Module For Mobile Starter with wire type antenna
26A21AV	85 - 265 VAC, Module For Mobile Starter with wire type antenna
26100P0 (Accessory)	SIM Card Tray
26100V0 (Accessory)	Wire type antenna

MOUNTING DIMENSIONS (mm)

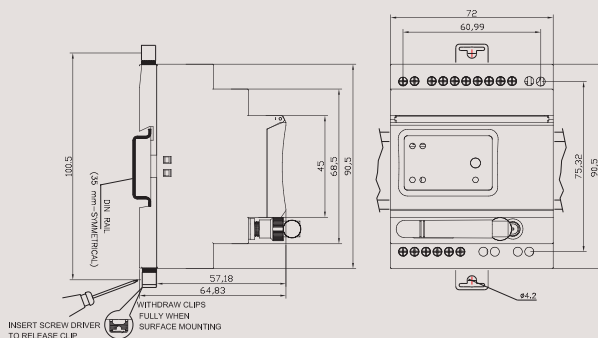

CONNECTION DIAGRAM

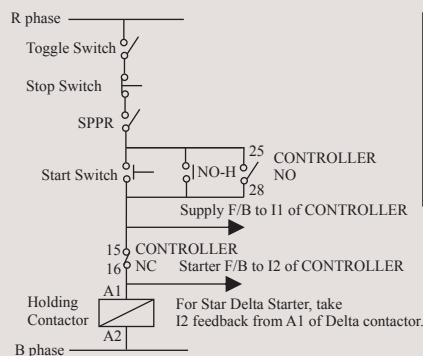

TERMINAL TORQUE & CAPACITY



	Torque - 0.54 N.m (5 Lb.in)
Ø 3.5 mm	Terminal screw - M2.5
	1 x 0.2...1 mm ² Solid Wire Single Wire Ferrule.
	2 x 0.2...1 mm ² Insulated Twin Wire Ferrule.
AWG	1 X 24 to 12



Configuration Steps

- | | |
|--|--|
| <p>Step 1: Insert SIM in the slot provided.</p> <p>Step 2: Power on device & wait for 35sec. ON (Green) LED will start blinking, indicating that device is in factory mode. After every power on, device will take 35 sec for initialization during which user should wait.</p> <p>Step 3: Ensure that NW (Network) LED is flashing after every 3 sec. It means device is registered with inserted SIM N/W. If NW LED is blinking faster, it means that the device is not registered with SIM NW & hence not ready for operation.</p> <p>Step 4: Press the CFG (Configuration) key on the device till CFG (RED) LED starts blinking. The device goes in the configuration mode to configure the master number in the device.</p> <p>Step 5: CFG LED will blink for 3 min, user should configure the master number within this time.</p> <p>Step 6: Call the device number, call will be disconnected after 1 to 2 rings.</p> | <p>Step 7: After call gets disconnected, ON LED stops blinking & becomes permanently ON. CFG LED turns OFF. This will indicate that, master number has been configured in the device.</p> <p>Step 8: To configure the monitor numbers if required, send query. 55<Space>no. 1<Space>no.2 from the master number.</p> <p>Step 9: After installing device for the first time, set the device clock by sending query "16". User will receive SMS," 16,"TIME ALREADY SET" or "16,"TIME SET TO ,DT: 15/12/12 ,TM:10:10:50 AM".</p> <p>Step 10: In order to receive balance info between every 16th to 20th SMS, set the balance code by sending query 14<space>*121# (*121# is the example for balance code. Balance code is changed as per Service Provider). User will receive SMS," 14,"BALANCE CODE UPDATED".</p> <p>Step 11: If device is connected in Semi Automatic Star Delta (SASD) starter then configure the device in SASD system by sending query 77<space>0. User will receive SMS, 77,"SYSTEM CONFIGURED FOR SASD"</p> <p>Step 12: After completion of above procedure, user should refer the "General SMS Queries" for further operation. Important Note: Whenever DST happens, set the device clock by sending query "16".</p> |
|--|--|

General SMS Queries : (To be sent only from Master number to Device number)

QUERY	DETAILS
Functionality Queries	
Call to device number or send SMS 11<space>0	After 3-4 rings device cuts the call & turns ON the starter or after receiving SMS 11 0 device turns ON the starter.
Call to device number or send SMS 00	After 5-6 rings device cuts the call & turns OFF the starter or after receiving SMS 00 device turns OFF the starter.
11<space>1 to 47	Starter ON with timer. Here 1=30 min, 2=1hr, 3=1.5hrs..... 47=23.50hrs. e.g. 11 4 query will turn on starter for 2 hrs from the time GSM receives the query.
22<space>ON time<space>OFF time.	Enable Daily Timer. Here ON & OFF time is in 24Hrs format only. e.g. 22 18 20 query will enable daily timer from 6pm to 8pm or 22 01 02 query will enable daily timer from 1am to 2 am. (Refer clock given below) To disable daily timer mode send same ON & OFF time i.e. 22 00 00.
66<space>1 or 0	GSM Auto mode Enable / Disable (1-Enable, 0- Disable). Factory default disable.
88	To know the available balance in prepaid account. (Note: Before sending this query first set the balance code by sending query 14).
99	To know current status of device.
INFO	To know all frequently used queries.
Configuration Queries	
44<space>last four digit of previous master number	For updating master number. To replace the previous master number with new one send query 44 xxxx from a new number which is to be configured as Master. (Note: 1. Before sending this query first press configuration key on device 2. After this query, previously stored Monitoring numbers will be deleted & new monitoring numbers need to be configured)
55<space>10 digit no.<space>10 digit no.	For pairing Monitoring numbers. By sending this query Master number can pair 2 monitoring numbers with device. To remove monitor numbers, send query 55 only.
77<space>0	Starter Configuration – SASD. Factory default disable. Send this query if GSM is installed in Semi Automatic Star Delta Starters.
 77<space>1	Starter configuration – DOL / Fully Automatic Star Delta (FASD). Factory default enable.
14<space>balance code	Set balance code. Balance code depends on Service provider. E.g. 14 *121# (*121# is balance code).
15<space>1 or 0	1-AUTO BAL INFO SMS ON, 0- AUTO BAL INFO SMS OFF. Factory default – AUTO BAL INFO SMS ON
 16	To set device clock.
17	To know configured master & monitor numbers.
Troubleshooting/ Security	
79	To put device in factory default setting provided CFG key is pressed till RED LED on device blinking.
12	To check signal strength.
13	To know IMEI number of the device.

NOTE : For monitor numbers only INFO, 99 , 16 & 12 queries are applicable.

PROTOCOL CONVERTERS

Lynx Gateway

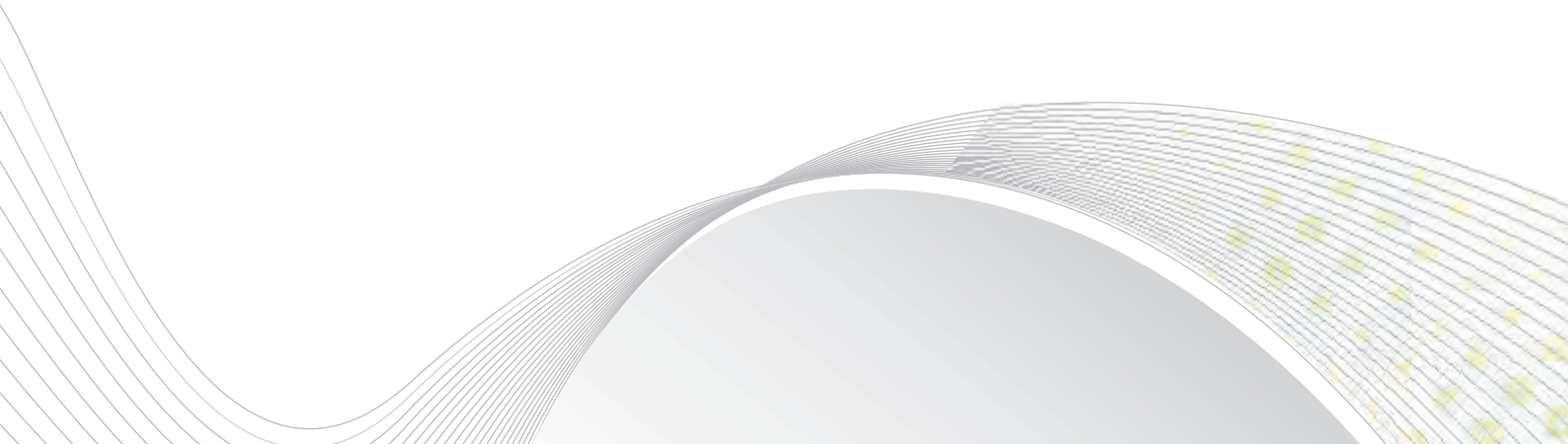

Lynx Gateway

- Serial protocol support for Modbus (RTU and ASCII) Master/Slave
- Network protocol support for Modbus TCP (Server/Client)
- Supports Raw Serial to Ethernet conversion with Telnet RFC2217
- Serial Interface support for RS232, RS422 and RS485 network
- Serial Baud rate: 300 bps to 115.2 Kbps
- Ethernet interface support: 10/100Mbps with Auto Negotiation
- Configurable using Embedded Web server and Application software
- Network Protocols: ARP, TCP/IP, HTTP, BOOTP, TFTP, ICMP, TELNET, DHCP, AutoIP
- Isolation between Communication Ports & Input Power supply



Cat. No.	25A11A0	25B11A0		
Parameters				
Supply Voltage (≡)	12 - 24 VDC			
Supply Variation	-10% to +25%			
Power Consumption (Max.)	2 W			
Protocol Conversion	Modbus RTU / ASCII to Modbus TCP	N.A		
Operation Mode	Modbus RTU / ASCII (Master / Slave), Modbus TCP (Server / Client)	Raw, Telnet		
Configuration Management	HTTP Web Server and Application software			
Serial Interface	Number of Serial Ports	1	2	
	Serial Interface	Port1: Screw terminals for RS232, RS422 and RS485 interface	Port1: Screw terminals for RS232, RS422 and RS485 interface, Port2: RJ11 for RS232 Interface	
	Signals	RS232 : RXD, TXD, GND		
		RS422 :TX+, TX-, RX+, RX-, GND		
		RS485 : TX+ (D+), TX- (D-), GND		
	Serial Interface Selection	For Port1: Mode selection using RST switch with Mode LED indication		
	Serial Communication Parameters	Baud Rate : 300bps to 115.2Kbps		
		Data Bits : 7,8 ; Flow Control : None		
		Parity : Odd, Even, None		
		Stop Bits : 1,2		
Fail safe resistor	4K7 Resistor Pull up (TX+) & Pull Down (TX-) on BUS			
Terminating Resistor	Connect externally if required			
Isolation	Isolation 2 KVrms			
LAN Interface	Port	RJ45, Ethernet 10/100 Mbps		
	LAN Isolation	1.5KVrms magnetic Isolation		
	Network Protocol's Supported	Protocols for Communication : TCP/IP, Modbus	Protocols for Communication : Raw, Telnet-RFC2217	
		Standard Protocols used : HTTP, DHCP, AutoIP, UPnP, TCP, UDP, IP, ARP, ICMP, Protocols used for firmware updating : BOOTP, TFTP	Standard Protocols used : HTTP, DHCP, AUTOIP, UPnP, TCP, UDP, IP, ARP, ICMP, Protocols used for firmware updating : BOOTP, TFTP	
		Isolation	1.5KVrms magnetic Isolation	
Feature	Mapping and Background Processing Data Block (BPD)	N.A		
Configuration Software	Windows Based Software to Configure Ports as well as Selection of Protocol Driver			
Reset	Front Panel recessed , Loads Default Factory Settings & Serial Mode selection			
LED Indications	Serial TX and RX, LAN: LINK and Activity, Power ON, Error, Mode Selection Indication LED			
Operating Temperature	0°C to + 55°C			
Enclosure	Flame Retardant UL94-V0			
Dimension (W x H x D) (in mm)	72 X 90 X 58			
Weight (unpacked)	185 g			
Mounting	Base / DIN Rail			
Certification	 			
EMI / EMC				
ESD	IEC 61000-4-2	Ed.2.0 (2008-12) Level – II Criteria – B, Level I Criteria – A		
EFT (On Supply Lines)	IEC 61000-4-4	Ed.3.0 (2012-04) Level IV Performance Criteria B and Level II Performance Criteria A		
EFT (On Communication Line)	Port-1 : IEC 61000-4-4	Ed. 3.0 (2012-04) Level – IV Criteria – B, Level II – Criteria – A, Port2 : Non Isolated		
Radiated Susceptibility	IEC 61000-4-3	Ed.3.2 (2010-04) Level III		
Surges (DC Power Ports)	IEC 61000-4-5	Ed.2.0 (2005-11) Level III		
Conducted Susceptibility	IEC 61000-4-6	Ed.3.0 (2008-10) Level III Criteria A		
Voltage Dips & Interruptions (AC)	IEC 61000-4-11	Ed.1.2 (2000-08) All 5 levels Criteria A		
Conducted Emission	CISPR 14-1	Ed. 5.2 (2011-11) Class A		
Radiated Emission	CISPR 14-1	Ed. 5.2 (2011-11) Class B		
Power Frequency Magnetic Field Immunity	IEC 61000-4-8	Ed. 2.0 (2009-09) class 4 Criteria A		
Environmental Compliance				
Cold Heat	IEC 60068-2-1	Ed. 6.0 (2007-03)		
Dry Heat	IEC 60068-2-2	Ed. 5.0 (2007-07)		
Vibration	IEC 60068-2-6	Ed. 7.0 (2007-12) 5g		
Repetitive Shock	IEC 60068-2-27	Ed. 4.0 (2008-02) 40g, 6ms		
Non-Repetitive Shock	IEC 60068-2-27	Ed. 4.0 (2008-02) 30g, 15ms		

ORDERING INFORMATION

Cat. No.	Description
25A11A0	12 - 24 VDC, Protocol Converter, Modbus TCP - Modbus RTU/ASCII
25B11A0	12 - 24 VDC, Serial to Ethernet Converter



MOUNTING DIMENSIONS (mm)

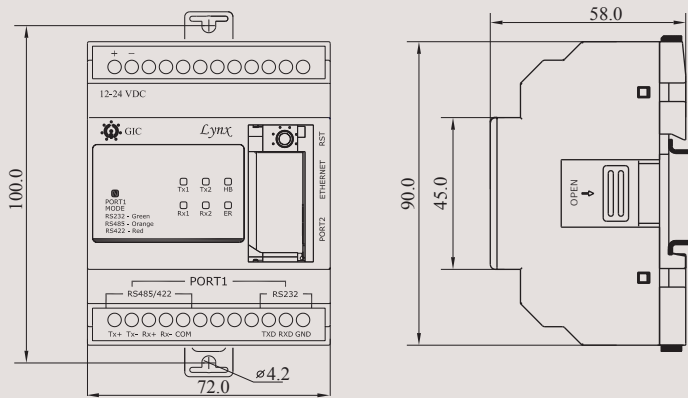

TERMINAL TORQUE & CAPACITY

	Torque - 1.1 N.m (10 Lb.in) Terminal screw - M3.5
	Solid Wire - 2 X 0.2...2.5 mm ²
AWG	1 X 24 to 10

INTERFACE CONVERTERS

USB to RS232 / RS485 / RS422 Converter

RS232 to RS485 / RS422 Converter

USB to RS232 / RS485 / RS422 Converter

- Compatible with USB 2.0
- Input : USB 2.0 Protocol
- Output : RS232 on DB9 Male connector compatible to PC RS485/RS422 on terminal block.
- Communication Speed : 300bps to 230Kbps.
- Auto direction control for RS485- 2W data transmission.
- Cable: USB 2.0 type A to type B cable.
- Galvanic Isolation of 1.5kV
- RS232/RS485 line protection: +/- 15kV ESD.
- LED Indication for Transmit Receive signals.
- Input power from USB port, no external power required.
- 2M enclosure with DIN Rail mounting.
- Virtual COM port USB Drivers provided for Win XP, Vista, Win7



Cat. No.

28A11A0

Parameters

USB

Version	USB Specification 2.0 compliant
Speed	12 Mbps

Isolated Serial Interface

RS232	TX, RX, GND
RS485	D+, D-, GND
RS422	TX+, TX-, RX+, RX-, GND
Auto direction control for RS485-2W	
Serial line Protection	Internal 15kV ESD protection
Isolation	1500 V Galvanic Isolation
Connector	RS232 - D Type 9 Pin Male Compatible with PC, RS485, RS422- Screw Terminals
LED Indication	TX, RX, Communication Mode Indication.
Power Requirements	USB BUS Powered
Operating Temperature	0° C To + 60° C
Storage Temperature	-20° C To + 70° C
Humidity	5% (Rh) to 95% (Rh)
Enclosure	Flame Retardant UL 94-V0
Dimension (W x H x D) (in mm)	36 X 90 X 52.3
Weight (unpacked) Approx.	100 g
Mounting	Base / DIN rail
Degree of Protection	IP 20 for Terminals, IP 40 for Enclosure
Certification	

Function and Application

This converter allows serial devices on RS232/RS485/RS422 to systems using USB interface. It has galvanic isolation of 1500V between USB and Serial ports. It drives power from USB connector and does not need any power adapter.

EMI / EMC

Harmonic Current Emissions	IEC 61000-3-2	Ed. 3.2 (2009-04) Class A
ESD	IEC 61000-4-2	Ed. 2.0 (2008-12) Level II
Radiated Susceptibility	IEC 61000-4-3	Ed. 3.2 (2010-04) Level III
Electrical Fast Transients	IEC 61000-4-4	Ed. 3.0 (2012-04) Level IV
Surges	IEC 61000-4-5	Ed. 2.0 (2005-11) Level IV
Conducted Susceptibility	IEC 61000-4-6	Ed. 3.0 (2008-10) Level III
Conducted Emission	CISPR 14-1	Ed. 5.2 (20011-11) Class A
Radiated Emission	CISPR 14-1	Ed. 5.2 (20011-11) Class A

Environmental

Cold Heat	IEC 60068-2-1	Ed. 6.0 (2007-03)
Dry Heat	IEC 60068-2-2	Ed. 5.0 (2007-07)
Vibration	IEC 60068-2-6	Ed. 7.0 (2007-12) 5g
Repetitive Shock	IEC 60068-2-27	Ed. 4.0 (2008-02) 40g, 6ms
Non-Repetitive Shock	IEC 60068-2-27	Ed. 4.0 (2008-02) 30g, 15ms

MOUNTING DIMENSIONS (mm)

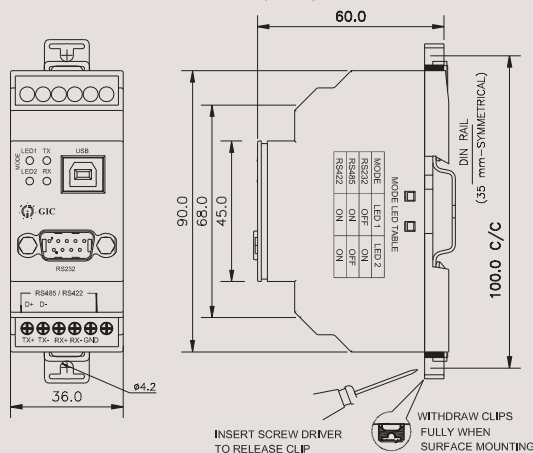

ORDERING INFORMATION

Cat. No.
28A11A0
28D33B0

Description

USB to RS232 / RS485 / RS422 Converter
Accessory for Converter 28A11A0, USB 2.0 Cable, Type A Male to B Male

POWER SUPPLIES

Switched Mode Power Supply

Switched Mode Power Supply

- Excellent Load & Line Regulation
- High Noise Immunity & Low Ripple
- No Load Power Consumption of less than 0.5W
- Overload & Short Circuit Protection
- High Efficiency of Operation
- Suitable for Temperatures upto 55°C
- Small Form Factor
- Peak Power Capacity



Cat. No.	24AS244D6D	24AS126D6D	
Parameters			
Supply Voltage (⌀)	230 VAC		
Supply Variation	-30% to +15%		
Frequency	50 Hz		
Power Consumption @ No Load	0.5W Max. @ 230 VAC		
AC Current	0.8A / 230 VAC	0.62A / 230 VAC	
Efficiency	> 85%	> 80%	
Inrush Current	Cold Start 50A / 230 VAC		
Leakage Current	< 0.2µA / 230 VAC		
Output	Voltage	24 VDC	12 VDC
	Rated Current	4A	6A
	Current Range	0 - 4A	0 - 6A
	Rated Power	96W	72W
	Output Voltage Accuracy	± 1%	
	Line Regulation	1%	
	Load Regulation	1%	
	Ripple & Noise	150 mV (P-P)	100 mV (P-P)
	Over Voltage Protection	26V ~ 33 V	13V ~ 16 V
	Over Load Capacity	168% of rated output (Max. 10s)	130% of rated output (Max. 10s)
Continuous Open Circuit	Normal Operation		
Over Current Protection	Voltage Drop		
Continuous Short Circuit Protection	Auto Recovery after fault condition is removed		
Start Up Time	3s Max. (At minimum input voltage and rated load)		
Hold Up Time	30ms Min. (At minimum input voltage and rated load)		
Withstand Voltage	Input to Output 3 KV AC for 1 Minute, 5 mA		
LED Indications	Green LED: Output ON		
Operating Temperature	-10°C to + 55°C		
Storage Temperature	-25°C to + 85°C		
Enclosure	Flame Retardant UL94-V0		
Dimension (W x H x D) (in mm)	108 X 90 X 58		
Weight (unpacked) Approx.	350 g		
Mounting	Base / DIN Rail		
Certification			
EMI / EMC			
Harmonic Current Emissions	IEC 61000-3-2	Ed. 3.2 (2009-04) Class A	
ESD	IEC 61000-4-2	Ed. 2.0 (2008-12) Level II	
Radiated Susceptibility	IEC 61000-4-3	Ed. 3.2 (2010-04) Level III	
Electrical Fast Transients	IEC 61000-4-4	Ed. 3.0 (2012-04) Level IV	
Surges	IEC 61000-4-5	Ed. 2.0 (2005-11) Level IV	
Conducted Susceptibility	IEC 61000-4-6	Ed. 3.0 (2008-10) Level III	
Voltage Dips & Interruptions (AC)	IEC 61000-4-11	Ed. 2.0 (2004-03) All 7 Levels	
Conducted Emission	CISPR 14-1	Ed. 5.2 (20011-11) Class A	
Radiated Emission	CISPR 14-1	Ed. 5.2 (20011-11) Class A	

ORDERING INFORMATION

Cat. No.	Description
24AS244D6D	96W, 230V AC, 24 VDC / 4A, Switched Mode Power Supply
24AS126D6D	72W, 230V AC, 12 VDC / 6A, Switched Mode Power Supply
24BS24AD4E	60W, 110 - 240 VAC, 24 VDC / 2.5A, Switched Mode Power Supply
24BS241D2F	24W, 110 - 240 VAC, 24 VDC / 1A, Switched Mode Power Supply
24BS24BD1F	12W, 110 - 240 VAC, 24 VDC / 0.5A, Switched Mode Power Supply
24BS051D1F	5W, 110 - 240 VAC, 5 VDC / 1.0A, Switched Mode Power Supply

Switched Mode Power Supply



MOUNTING DIMENSIONS (mm)

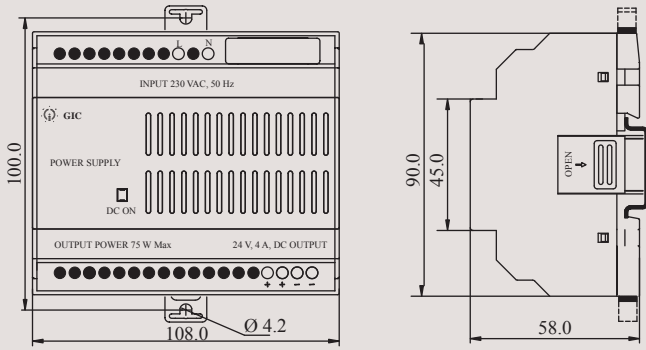

24AS244D6D, 24AS126D6D

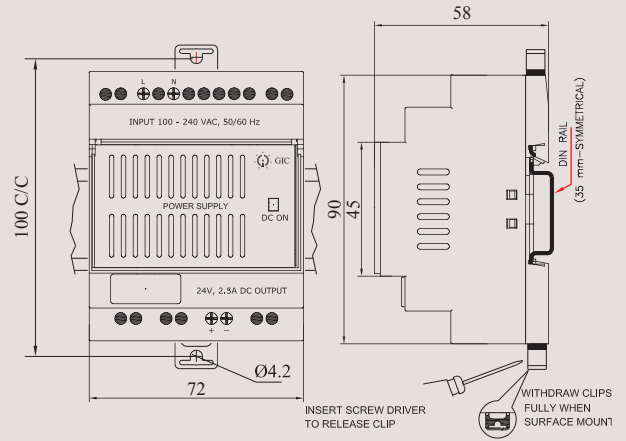

24BS24AD4E

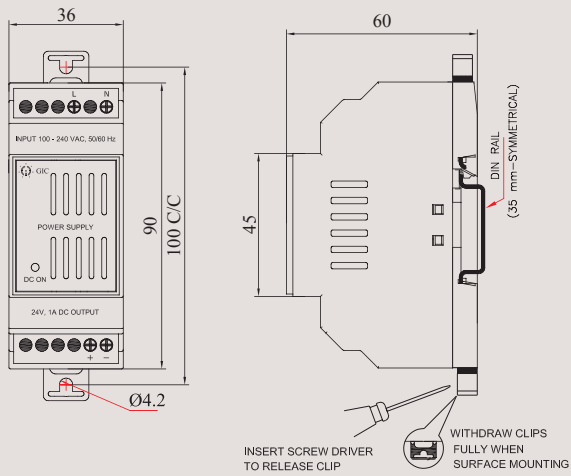

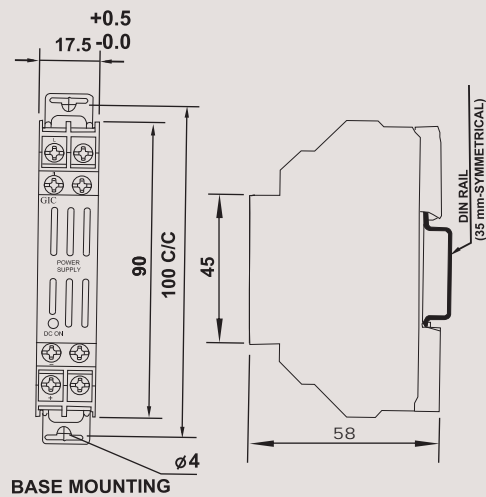

24BS241D2F



BASE MOUNTING

24BS24BD1F, 24BS051D1F

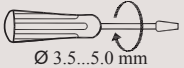
TERMINAL TORQUE & CAPACITY

 Ø 3.5...5.0 mm	Torque - 1.1 N.m (10 Lb.in) Terminal screw - M3.5
	Solid Wire - 2 X 0.2...2.5 mm ²
AWG	1 X 24 to 10

SUPPLY MONITORING DEVICES

Supply Monitoring Series SM 301

Supply Monitoring Series SM 500

Supply Monitoring Series SM 501

Supply Monitoring Series SM 175

Supply Monitoring Series - Three Phase Indicator

Frequency Monitoring Series PD 225

PTC Thermistor Series PD225

PTC Thermistor & Single Phasing Preventer Series PD225

Supply Monitoring Series CMR - Current Control

Earth Leakage Relay Series CMR

Supply Monitoring Series SM 301

- Protects against Phase Loss, Phase Reversal & Phase Asymmetry
- No Auxiliary Supply needed
- Voltage Sensing principle
- 1 C/O & 2 C/O Configurations
- Designed to meet Industrial and Agricultural segment applications



Cat. No.		MA51BC	MA51BK	MC21B5
Parameters				
Supply Voltage (⊕)		415 VAC		
Frequency		50/60 Hz		
Power Consumption (Max.)		15 VA		
Trip Settings	Phase Loss	Yes	Yes	Yes
	Phase Sequence	Yes	Yes	Yes
	Phase Asymmetry	65 V (± 10V)	40 V (± 10 V)	65 V (± 10V)
	Hysteresis	10 to 18 V	10 to 18 V	10 to 18 V
Time Delay	ON Delay	2 s (± 2 s)	2 s (± 2 s)	< 550 ms
	Trip Time (OFF Delay)	7 s (± 2 s)	7 s (± 2 s)	< 550 ms
Output	Relay Output	1 C/O		2 C/O
	Contact Rating	5A (For 'NO') & 3A (For 'NC') @ 250 VAC / 28 VDC (Resistive)		5A @ 250 VAC / 28 VDC (Resistive)
	Electrical Life	1X10 ⁵		
	Mechanical Life	3X10 ⁶		
Utilization Category	AC - 15	Rated Voltage (Ue): 120/240 V, Rated Current (Ie): 3.0/1.5 A		
	DC - 13	Rated Voltage (Ue): 24/125/250 V, Rated Current (Ie): 2.0/0.22/0.1 A		
LED Indication		Red → Relay ON (Healthy), See Note 1		
Operating Temperature		- 15° C to + 50° C		
Storage Temperature		- 20° C to + 65° C		
Humidity (Non Condensing)		95% (Rh)		
Enclosure		Flame Retardant UL 94-V0		
Dimension (W x H x D) (in mm)		36 X 90 X 60		
Weight (unpacked)		120 g		
Mounting		Base / DIN rail		
Degree of Protection		IP20 for Terminals, IP 40 for Enclosure		
Certification		 		
EMI / EMC				
Harmonic Current Emissions		IEC 61000-3-2	Ed. 3.2 (2009-04) Class A	
ESD		IEC 61000-4-2	Ed. 2.0 (2008-12) Level II	
Radiated Susceptibility		IEC 61000-4-3	Ed. 3.2 (2010-04) Level III	
Electrical Fast Transients		IEC 61000-4-4	Ed. 3.0 (2012-04) Level IV	
Surges		IEC 61000-4-5	Ed. 2.0 (2005-11) Level IV	
Conducted Susceptibility		IEC 61000-4-6	Ed. 3.0 (2008-10) Level III	
Voltage Dips & Interruptions (AC)		IEC 61000-4-11	Ed. 2.0 (2004-03) All 7 Levels	
Conducted Emission		CISPR 14-1	Ed. 5.2 (20011-11) Class A	
Radiated Emission		CISPR 14-1	Ed. 5.2 (20011-11) Class A	
Environmental				
Cold Heat		IEC 60068-2-1	Ed. 6.0 (2007-03)	
Dry Heat		IEC 60068-2-2	Ed. 5.0 (2007-07)	
Vibration		IEC 60068-2-6	Ed. 7.0 (2007-12) 5g	
Repetitive Shock		IEC 60068-2-27	Ed. 4.0 (2008-02) 40g, 6ms	
Non-Repetitive Shock		IEC 60068-2-27	Ed. 4.0 (2008-02) 30g, 15ms	

ORDERING INFORMATION

Cat. No.	Description
MA51BC	415 VAC, Single Phasing Preventor with 65 VAC Asymmetry, 1 C/O
MA51BK	415 VAC, Single Phasing Preventor with 40 VAC Asymmetry, 1 C/O
MC21B5	415 VAC, Single Phasing Preventor with 65 VAC Asymmetry, 2 C/O

Note 1:- ON: Relay ON, OFF: Phase Loss, Blinking: Asymmetry (200 ms, On/Off), Flashing: Phase Sequence (1 s, On/Off)

Supply Monitoring Series SM 500

- Protects against Phase Loss, Phase Reversal & Phase Asymmetry
- Can be configured for 3 Phase 4 Wire or 1 Phase system
- Selectable Over Voltage / Under Voltage Trip level
- Selectable Time Delay
- LED Indications for Power and Fault conditions
- Voltage Sensing principle
- 1 C/O or 2 C/O Configuration



Cat. No.		MD71B9	MD71BH	MD71BF
Parameters				
Supply Voltage (ϕ)		240 VAC (1 Phase & 3 Phase, 4 Wire)		
Frequency		50/60 Hz		
Power Consumption (Max.)		5 VA		
Trip Settings	Phase Loss	Yes	Yes	Yes
	Phase Sequence	N.A	N.A	N.A
	Phase Asymmetry	N.A	N.A	N.A
	Under Voltage	55% to 95% (of ϕ)		
	Over Voltage	105% to 125% (of ϕ)		
Time Delay	ON Delay	0 to 15 min (Selectable)	0 to 15 s (Selectable)	5 s
	Trip Time (OFF Delay)	5 s	5 s	0 to 15 s (Selectable)
Output	Relay Output	1 C/O		
	Contact Rating	5A @ 250 VAC / 28 VDC (Resistive)		
	Electrical Life	1X10 ⁵		
	Mechanical Life	3X10 ⁶		
Utilization Category	AC - 15	Rated Voltage (Ue): 120/240 V, Rated Current (Ie): 3.0/1.5 A		
	DC - 13	Rated Voltage (Ue): 24/125/250 V, Rated Current (Ie): 2.0/0.22/0.1 A		
LED Indication		Separate indications for Power ON, UV and OV		
Operating Temperature		-15° C To + 55° C		
Storage Temperature		-25° C To + 70° C		
Humidity (Non Condensing)		95% (Rh)		
Enclosure		Flame Retardant UL 94-V0		
Dimension (W x H x D) (in mm)		36 X 90 X 60		
Weight (unpacked)		120 g		
Mounting		Base / DIN rail		
Degree of Protection		IP 20 for Terminals, IP 40 for Enclosure		
Certification		 		
EMI / EMC				
Harmonic Current Emissions		IEC 61000-3-2	Ed. 3.2 (2009-04) Class A	
ESD		IEC 61000-4-2	Ed. 2.0 (2008-12) Level II	
Radiated Susceptibility		IEC 61000-4-3	Ed. 3.2 (2010-04) Level III	
Electrical Fast Transients		IEC 61000-4-4	Ed. 3.0 (2012-04) Level IV	
Surges		IEC 61000-4-5	Ed. 2.0 (2005-11) Level IV	
Conducted Susceptibility		IEC 61000-4-6	Ed. 3.0 (2008-10) Level III	
Voltage Dips & Interruptions (AC)		IEC 61000-4-11	Ed. 2.0 (2004-03) All 7 Levels	
Conducted Emission		CISPR 14-1	Ed. 5.2 (2011-11) Class A	
Radiated Emission		CISPR 14-1	Ed. 5.2 (2011-11) Class A	
Environmental				
Cold Heat		IEC 60068-2-1	Ed. 6.0 (2007-03)	
Dry Heat		IEC 60068-2-2	Ed. 5.0 (2007-07)	
Vibration		IEC 60068-2-6	Ed. 7.0 (2007-12) 5g	
Repetitive Shock		IEC 60068-2-27	Ed. 4.0 (2008-02) 40g, 6ms	
Non-Repetitive Shock		IEC 60068-2-27	Ed. 4.0 (2008-02) 30g, 15ms	
Note: 1) Voltage setting is with respect to Neutral. Voltage Setting Accuracy: $\pm 5\%$ of Full Scale; Time Setting Accuracy: $\pm 10\%$ of Full Scale				

ORDERING INFORMATION

Cat. No.	Description
MD71B9	240 VAC, Under Voltage / Over Voltage with Selectable ON Delay (0 to 15 min), 1 C/O
MD71BH	240 VAC, Under Voltage / Over Voltage with Selectable ON Delay (0 to 15 sec), 1 C/O
MD71BF	240 VAC, Under Voltage / Over Voltage with Selectable OFF Delay (0 to 15 sec), 1 C/O



Cat. No.		MG73BH	MG73BF	MG73B9
Parameters				
Supply Voltage (ϕ)		240 VAC (1 Phase & 3 Phase, 4 Wire)		
Frequency		50/60 Hz		
Power Consumption (Max.)		5 VA		
Trip Settings	Phase Loss	Yes		
	Phase Sequence	Yes		
	Phase Asymmetry	10% (of ϕ)		
	Under Voltage	55% to 95% (of ϕ)		
	Over Voltage	105% to 125% (of ϕ)		
	Hysteresis	7 V (\pm 2 V)		
Time Delay	ON Delay	0.5 s to 15 s (Selectable)	5 s	0.5 to 15 min (Selectable)
	Trip Time (OFF Delay)	5 s	0.5 s to 15 s (Selectable)	5 s
Output	Relay Output	2 C/O		
	Contact Rating	5A @ 250 VAC / 28 VDC (Resistive)		
	Electrical Life	1X10 ⁵		
	Mechanical Life	3X10 ⁶		
Utilization Category	AC - 15	Rated Voltage (Ue): 120/240 V, Rated Current (Ie): 3.0/1.5 A		
	DC - 13	Rated Voltage (Ue): 24/125/250 V, Rated Current (Ie): 2.0/0.22/0.1 A		
LED Indication		Separate indications for Power ON, UV and OV; ON: Phase Reverse; BLINK: Phase Asymmetry		
Operating Temperature		-15° C To + 55° C		
Storage Temperature		-25° C To + 70° C		
Humidity (Non Condensing)		95% (Rh)		
Enclosure		Flame Retardant UL 94-V0		
Dimension (W x H x D) (in mm)		36 X 90 X 60		
Weight (unpacked)		120 g		
Mounting		Base / DIN rail		
Degree of Protection		IP 20 for Terminals, IP 40 for Enclosure		
Certification		 		
EMI / EMC				
Harmonic Current Emissions		IEC 61000-3-2	Ed. 3.2 (2009-04) Class A	
ESD		IEC 61000-4-2	Ed. 2.0 (2008-12) Level II	
Radiated Susceptibility		IEC 61000-4-3	Ed. 3.2 (2010-04) Level III	
Electrical Fast Transients		IEC 61000-4-4	Ed. 3.0 (2012-04) Level IV	
Surges		IEC 61000-4-5	Ed. 2.0 (2005-11) Level IV	
Conducted Susceptibility		IEC 61000-4-6	Ed. 3.0 (2008-10) Level III	
Voltage Dips & Interruptions (AC)		IEC 61000-4-11	Ed. 2.0 (2004-03) All 7 Levels	
Conducted Emission		CISPR 14-1	Ed. 5.2 (20011-11) Class A	
Radiated Emission		CISPR 14-1	Ed. 5.2 (20011-11) Class A	
Environmental				
Cold Heat		IEC 60068-2-1	Ed. 6.0 (2007-03)	
Dry Heat		IEC 60068-2-2	Ed. 5.0 (2007-07)	
Vibration		IEC 60068-2-6	Ed. 7.0 (2007-12) 5g	
Repetitive Shock		IEC 60068-2-27	Ed. 4.0 (2008-02) 40g, 6ms	
Non-Repetitive Shock		IEC 60068-2-27	Ed. 4.0 (2008-02) 30g, 15ms	

Note: 1) Voltage setting is with respect to Neutral. Voltage Setting Accuracy: \pm 5 % of Full Scale; Time Setting Accuracy: \pm 10 % of Full Scale



ORDERING INFORMATION

Cat. No.	Description
MG73B9	240 VAC, UV / OV & Single Phasing Preventor (SPP) with Selectable ON Delay (0 to 15 min), 2 C/O
MG73BH	240 VAC, UV / OV & SPP with Selectable ON Delay (0 to 15 sec), 2 C/O
MGH3BH	220 VAC, UV / OV & SPP with Selectable ON Delay (0 to 15 sec), 2 C/O
MG73BF	240 VAC, UV / OV & SPP with Selectable OFF Delay (0 to 15 sec), 2 C/O
MGI3BF	230 VAC, UV / OV & SPP with Selectable OFF Delay (0 to 15 sec), 2 C/O

Supply Monitoring Series SM500 - Neutral Loss Protection

- Phase loss (failure) detection.
- Neutral loss detection.
- Phase reverse detection.
- Phase asymmetry.
- Adjustable Over & Under voltage trip level.
- LED indication for all failure conditions.
- Automatic recovery on fault removal.



Cat. No.		MAC04D0100			
Parameters					
Supply Voltage (ϕ)		415 VAC (Ph-Ph); 3 Phase, 4 Wire			
Frequency		47 to 53 Hz			
Power Consumption (Max.)		10 VA (max)			
Trip Settings	Phase Loss	Yes			
	Phase Sequence	Yes			
	Phase Asymmetry	94V \pm 4V (Ph-Ph)			
	Under Voltage	55% to 95% (of ϕ)			
	Over Voltage	105% to 125% (of ϕ)			
	Hysteresis	7 V (\pm 2 V)			
Time Delay	ON Delay	5 s \pm 1 s (Fixed)			
	Trip Time (OFF Delay)	For Phase failure phase Imbalance	5 s \pm 1 s (Fixed)		
		For Neutral Fail	500 ms -1s		
Output	Relay Output	2 C/O			
	Contact Rating	5A @ 250 VAC / 28 VDC (Resistive)			
	Electrical Life	1X10 ⁵			
	Mechanical Life	1X10 ⁷			
Utilization Category	AC - 15	Rated Voltage (Ue): 120/240 V, Rated Current (Ie): 3.0/1.5 A			
	DC - 13	Rated Voltage (Ue): 24/125/250 V, Rated Current (Ie): 2.0/0.22/0.1 A			
LED Indications on front plate	Respective fault condition will be indicated by LED immediately & Relay will be tripped after specified trip time only.				
		GREEN	UV	OV	Blink: ASY, ON: REV
	Power ON	ON	OFF	OFF	OFF
	Phase reverse	ON	OFF	OFF	ON
	Asymmetry	ON	OFF	OFF	BLINK
	UV	ON	ON	OFF	OFF
	OV	ON	OFF	ON	OFF
	Phase Fail	BLINK	OFF	OFF	OFF
	Phase Fail *	BLINK	ON	OFF	BLINK
	Neutral Fail	ON	BLINK	BLINK	BLINK
* Phase fail indications when I/P voltages are below UV set point and below asymmetry					
Operating Temperature		-10° C To + 60° C			
Storage Temperature		-10° C To + 70° C			
Humidity (Non Condensing)		95% (Rh)			
Enclosure		Flame Retardant UL 94-V0			
Dimension (W x H x D) (in mm)		36 X 90 X 60			
Weight (unpacked)		120 g			
Mounting		Base / DIN rail			
Degree of Protection		IP 20 for Terminals, IP 40 for Enclosure			
Certification		 			
EMI / EMC					
Harmonic Current Emissions		IEC 61000-3-2	Ed. 3.2 (2009-04) Class A		
ESD		IEC 61000-4-2	Ed. 2.0 (2008-12) Level II		
Radiated Susceptibility		IEC 61000-4-3	Ed. 3.2 (2010-04) Level III		
Electrical Fast Transients		IEC 61000-4-4	Ed. 3.0 (2012-04) Level IV		
Surges		IEC 61000-4-5	Ed. 2.0 (2005-11) Level IV		
Conducted Susceptibility		IEC 61000-4-6	Ed. 3.0 (2008-10) Level III		
Voltage Dips & Interruptions (AC)		IEC 61000-4-11	Ed. 2.0 (2004-03) All 7 Levels		
Conducted Emission		CISPR 14-1	Ed. 5.2 (20011-11) Class A		
Radiated Emission		CISPR 14-1	Ed. 5.2 (20011-11) Class A		
Environmental					
Cold Heat		IEC 60068-2-1	Ed. 6.0 (2007-03)		
Dry Heat		IEC 60068-2-2	Ed. 5.0 (2007-07)		
Vibration		IEC 60068-2-6	Ed. 7.0 (2007-12) 5g		
Repetitive Shock		IEC 60068-2-27	Ed. 4.0 (2008-02) 40g, 6ms		
Non-Repetitive Shock		IEC 60068-2-27	Ed. 4.0 (2008-02) 30g, 15ms		

ORDERING INFORMATION

Cat. No.	Description
MAC04D0100	415V AC, Neutral Loss Protection with Phase and Voltage Control, 2 C/O

Supply Monitoring Series SM 501

- Protects against Phase Loss, Phase Reversal & Phase Asymmetry
- Suitable for 3 Phase 3 Wire system
- Selectable Under Voltage / Over Voltage Trip level
- Selectable Time Delay
- Models for Selectable Phase Asymmetry
- LED Indications for Power and Fault conditions
- Voltage Sensing Principle
- 2 C/O Configuration



Cat. No.		MG53BH	MG53BF	MG63BH	MG63BF
Parameters					
Supply Voltage (ϕ)		415 VAC (3 Phase, 3 Wire)		220 VAC (3 Phase, 3 Wire)	
Frequency		50/60 Hz			
Power Consumption (Max.)		10 VA		5 VA	
Trip Settings	Phase Loss	Yes			
	Phase Sequence	Yes			
	Phase Asymmetry	10% (of ϕ)			
	Under Voltage	55% to 95% (of ϕ)			
	Over Voltage	105% to 125% (of ϕ)			
	Hysteresis	7 V (\pm 2 V) of Trip Voltage			
Time Delay	ON Delay	0 to 15 s (Selectable)	5 s	0 to 15 s (Selectable)	5 s
	Trip Time (OFF Delay)	5 s	0 to 15 s (Selectable)	5 s	0 to 15 s (Selectable)
Output	Relay Output	2 C/O			
	Contact Rating	5A @ 250 VAC / 28 VDC (Resistive)			
	Electrical Life	1X10 ⁵			
	Mechanical Life	3X10 ⁶			
Utilization Category	AC - 15	Rated Voltage (Ue): 120/240 V, Rated Current (Ie): 3.0/1.5 A			
	DC - 13	Rated Voltage (Ue): 24/125/250 V, Rated Current (Ie): 2.0/0.22/0.1 A			
LED Indication		Separate indications for Power ON, UV and OV; ON: Phase Reverse; BLINK: Phase Asymmetry			
Operating Temperature		-15° C To + 55° C			
Storage Temperature		-25° C To + 70° C			
Humidity (Non Condensing)		95% (Rh)			
Enclosure		Flame Retardant UL 94-V0			
Dimension (W x H x D) (in mm)		36 X 90 X 60			
Weight (unpacked)		120 g			
Mounting		Base / DIN rail			
Degree of Protection		IP 20 for Terminals, IP 40 for Enclosure			
Certification		 			
EMI / EMC					
Harmonic Current Emissions		IEC 61000-3-2	Ed. 3.2 (2009-04) Class A		
ESD		IEC 61000-4-2	Ed. 2.0 (2008-12) Level III		
Radiated Susceptibility		IEC 61000-4-3	Ed. 3.2 (2010-04) Level III		
Electrical Fast Transients		IEC 61000-4-4	Ed. 3.0 (2012-04) Level IV		
Surges		IEC 61000-4-5	Ed. 2.0 (2005-11) Level IV		
Conducted Susceptibility		IEC 61000-4-6	Ed. 3.0 (2008-10) Level III		
Voltage Dips & Interruptions (AC)		IEC 61000-4-11	Ed. 2.0 (2004-03) All 7 Levels		
Conducted Emission		CISPR 14-1	Ed. 5.2 (20011-11) Class A		
Radiated Emission		CISPR 14-1	Ed. 5.2 (20011-11) Class B		
Environmental					
Cold Heat		IEC 60068-2-1	Ed. 6.0 (2007-03)		
Dry Heat		IEC 60068-2-2	Ed. 5.0 (2007-07)		
Vibration		IEC 60068-2-6	Ed. 7.0 (2007-12) 5g		
Repetitive Shock		IEC 60068-2-27	Ed. 4.0 (2008-02) 40g, 6ms		
Non-Repetitive Shock		IEC 60068-2-27	Ed. 4.0 (2008-02) 30g, 15ms		

Note: 1) Voltage Setting Accuracy: \pm 5 % of Full Scale; Time Setting Accuracy: \pm 10 % of Full Scale
 2) In the event of Phase Sequence or Phase Loss, OFF Delay is 100 ms

ORDERING INFORMATION

Cat. No.	Description
MG53BH	415 VAC, UV / OV & Single Phasing Preventor (SPP) with Selectable ON Delay (0.5 to 15 sec), 2 C/O
MG53BF	415 VAC, UV / OV & SPP with Selectable OFF Delay (0.5 to 15 sec), 2 C/O
MG63BH	220 VAC, UV / OV & SPP with Selectable ON Delay (0.5 to 15 sec), 2 C/O
MG63BF	220 VAC, UV / OV & SPP with Selectable OFF Delay (0.5 to 15 sec), 2 C/O

Supply Monitoring Series SM 501



Cat. No.		MG53BI	MG53BO	MB53BM
Parameters				
Supply Voltage (ϕ)		415 VAC (3 Phase, 3 Wire)		
Frequency		50/60 Hz		
Power Consumption (Max.)		10 VA		
Trip Settings	Phase Loss	Yes	Yes	Yes
	Phase Sequence	Yes	Yes	Yes
	Phase Asymmetry	65 V	10%	5% to 17%
	Under Voltage	55% to 95% (of ϕ)	85% (of ϕ) Fixed	80% (of ϕ) Symmetrical
	Over Voltage	105% to 125% (of ϕ)	110% (of ϕ) Fixed	110% Fixed
	Hysteresis	7 V (\pm 2 V) of Trip Voltage	7 V (\pm 2 V) of Trip Voltage	7 V (\pm 2 V) of Input Voltage
Time Delay	ON Delay	5 s	3 min	0.5 to 15 s (Selectable)
	Trip Time (OFF Delay)	5 s	5 s	0.5 to 15 s (Selectable)
Output	Relay Output	2 C/O		
	Contact Rating	5A @ 250 VAC / 28 VDC (Resistive)		
	Electrical Life	1X10 ⁵		
	Mechanical Life	3X10 ⁶		
Utilization Category	AC - 15	Rated Voltage (Ue): 120/240 V, Rated Current (Ie): 3.0/1.5 A		
	DC - 13	Rated Voltage (Ue): 24/125/250 V, Rated Current (Ie): 2.0/0.22/0.1 A		
LED Indication	Separate indications for Power ON, UV and OV; ON: Phase Reverse; BLINK: Phase Asymmetry			
Operating Temperature	-15° C To + 55° C			
Storage Temperature	-25° C To + 70° C			
Humidity (Non Condensing)	95% (Rh)			
Enclosure	Flame Retardant UL 94-V0			
Dimension (W x H x D) (in mm)	36 X 90 X 60			
Weight (unpacked)	120 g			
Mounting	Base / DIN rail			
Degree of Protection	IP 20 for Terminals, IP 40 for Enclosure			
Certification	 			
EMI / EMC				
Harmonic Current Emissions	IEC 61000-3-2	Ed. 3.2 (2009-04) Class A		
ESD	IEC 61000-4-2	Ed. 2.0 (2008-12) Level III		
Radiated Susceptibility	IEC 61000-4-3	Ed. 3.2 (2010-04) Level III		
Electrical Fast Transients	IEC 61000-4-4	Ed. 3.0 (2012-04) Level IV		
Surges	IEC 61000-4-5	Ed. 2.0 (2005-11) Level IV		
Conducted Susceptibility	IEC 61000-4-6	Ed. 3.0 (2008-10) Level III		
Voltage Dips & Interruptions (AC)	IEC 61000-4-11	Ed. 2.0 (2004-03) All 7 Levels		
Conducted Emission	CISPR 14-1	Ed. 5.2 (20011-11) Class A		
Radiated Emission	CISPR 14-1	Ed. 5.2 (20011-11) Class B		
Environmental				
Cold Heat	IEC 60068-2-1	Ed. 6.0 (2007-03)		
Dry Heat	IEC 60068-2-2	Ed. 5.0 (2007-07)		
Vibration	IEC 60068-2-6	Ed. 7.0 (2007-12) 5g		
Repetitive Shock	IEC 60068-2-27	Ed. 4.0 (2008-02) 40g, 6ms		
Non-Repetitive Shock	IEC 60068-2-27	Ed. 4.0 (2008-02) 30g, 15ms		

ORDERING INFORMATION

Cat. No.	Description
MG53BI	415 VAC, UV / OV & Single Phasing Preventor (SPP) with 65 V Asymmetry, 2 C/O
MG53BO	415 VAC, UV / OV & SPP with 3 min ON Delay & 5s OFF Delay, 2 C/O
MB53BM	415 VAC, UV / OV (110% Fixed) & SPP with Selectable Asymmetry (5% to 17%), 2 C/O
MG53BQ	415 VAC, UV / OV & SPP with 30 V Asymmetry, 3 Sec ON Delay, 2 C/O

Note: 1) Voltage Setting Accuracy: \pm 5 % of Full Scale; Time Setting Accuracy: \pm 10 % of Full Scale

2) In the event of Phase Sequence or Phase Loss, OFF Delay is 100 ms

3) MG53BQ does not detect Phase Sequence Fault

Supply Monitoring Series SM 175





- Compact 17.5 mm Wide
- Protects against Phase Loss, Phase Reversal & Phase Asymmetry
- Multi-Voltage: 3 x 208 to 3 x 480 V
- Selectable Under Voltage / Over Voltage & Asymmetry
- LED Indication for all Faults & for change in settings during run time for better security
- Adjustable Time Delay
- 1 C/O Configuration

Cat. No.		MN21D5	MK21D5	MC21D5	MA21DN
Parameters					
Supply Voltage (Φ)		208 - 480 VAC, (3 Phase 3 Wire)			
Supply Variation		-12% to + 10% (of Φ)			
Frequency		50/60 Hz			
Power Consumption (Max.)		3.5 VA			
Trip Levels	Phase Loss	Yes	Yes	Yes	Yes
	Phase Sequence	N A	Yes	Yes	Yes
	Phase Asymmetry	N A	N A	30% Fixed	5% to 15%
Time Delay	ON Delay	< 750 ms	< 750 ms	< 750 ms	5s
	Trip Time (OFF Delay)	< 65 ms	100 ms	100 ms	0.5 to 15 s (Selectable)
Output	Relay Output	1 C/O			
	Contact Rating	5A @ 250 VAC / 30 VDC (Resistive)			
	Electrical Life	1X10 ⁵			
	Mechanical Life	3X10 ⁶			
Utilization Category	AC - 15	Rated Voltage (Ue): 120/240 V, Rated Current (Ie): 3.0/1.5 A			
	DC - 13	Rated Voltage (Ue): 24/125/250 V, Rated Current (Ie): 2.0/0.22/0.1 A			
LED Indication	Healthy	Relay LED Continuous ON			
	Phase Reverse	N A	Relay LED Flashing		
	Asymmetry	Relay LED Off (Red Colour)	N A	Relay LED Off (Red Colour)	
Operating Temperature		- 15° C to +60° C			
Storage Temperature		- 20° C to +80° C			
Humidity (Non Condensing)		95% (Rh)			
Enclosure		Flame Retardant UL 94-V0			
Dimension (W x H x D) (in mm)		17.5 X 90 X 58.5			
Weight (unpacked)		70 g			
Mounting		Base / DIN rail			
Degree of Protection		IP 20 for Terminal, IP 30 for Enclosure			
Certification		  			
EMI / EMC					
Harmonic Current Emissions		IEC 61000-3-2	Ed. 3.2 (2009-04) Class A		
ESD		IEC 61000-4-2	Ed. 2.0 (2008-12) Level III		
Radiated Susceptibility		IEC 61000-4-3	Ed. 3.2 (2010-04) Level III		
Electrical Fast Transients		IEC 61000-4-4	Ed. 3.0 (2012-04) Level IV		
Surges		IEC 61000-4-5	Ed. 2.0 (2005-11) Level IV		
Conducted Susceptibility		IEC 61000-4-6	Ed. 3.0 (2008-10) Level III		
Voltage Dips & Interruptions (AC)		IEC 61000-4-11	Ed. 2.0 (2004-03) All 7 Levels		
Conducted Emission		CISPR 14-1	Ed. 5.2 (2011-11) Class A		
Radiated Emission		CISPR 14-1	Ed. 5.2 (2011-11) Class B		
Environmental					
Cold Heat		IEC 60068-2-1	Ed. 6.0 (2007-03)		
Dry Heat		IEC 60068-2-2	Ed. 5.0 (2007-07)		
Vibration		IEC 60068-2-6	Ed. 7.0 (2007-12) 5g		
Repetitive Shock		IEC 60068-2-27	Ed. 4.0 (2008-02) 40g, 6ms		
Non-Repetitive Shock		IEC 60068-2-27	Ed. 4.0 (2008-02) 30g, 15ms		

ORDERING INFORMATION

Cat. No.	Description
MN21D5	208 - 480 VAC, Phase Loss Monitoring, 1 C/O
MK21D5	208 - 480 VAC, Phase Loss, Phase Sequence Monitoring , 1 C/O
MC21D5	208 - 480 VAC, Phase Loss, Phase Sequence, Phase Asymmetry Monitoring (30% Fixed), 1 C/O
MA21DN	208 - 480 VAC, Phase Loss, Phase Sequence, Phase Asymmetry Monitoring (5% to 15% Variable), 1 C/O
MOF1D51	208 - 480 VAC, Phase Loss, Phase Asymmetry Monitoring (10% Fixed), with trip time < 65 ms, 1 C/O



Cat. No.		MD21DF	MG21DH	MG21DF	MGD1DR
Parameters					
Supply Voltage (φ)		208 - 480 VAC, (3 Phase 3 Wire)			400 VAC, (3 Phase 3 Wire)
Supply Variation		-12% to + 10% (of φ)			
Frequency		50/60 Hz			
Power Consumption (Max.)		3.5 VA			
Settable Nominal Voltage		208 - 220 - 380 - 400 - 415 - 440 - 480 VAC			N A
Trip Levels	Phase Loss	Yes			
	Phase Sequence	Yes			
	Phase Asymmetry	N A		10% Fixed	
	Under Voltage	-2% to -20% (of φ)		-5% to -25% (of φ)	
	Over Voltage	+2% to +20% (of φ)		+5% to +25% (of φ)	
Time Delay	ON Delay	5 s	0.5 to 100 s (Selectable)	5 s	0.5 to 100 s (Selectable)
	Trip Time (OFF Delay)	0.5 to 15 s (Selectable)	5 s	0.5 to 100 s (Selectable)	0.5 to 15 s (Selectable)
Output	Relay Output	1 C/O			
	Contact Rating	5A @ 250 VAC / 30 VDC (Resistive)			
	Electrical Life	1X10 ⁵			
	Mechanical Life	3X10 ⁶			
Utilization Category	AC - 15	Rated Voltage (Ue): 120/240 V, Rated Current (Ie): 3.0/1.5 A			
	DC - 13	Rated Voltage (Ue): 24/125/250 V, Rated Current (Ie): 2.0/0.22/0.1 A			
LED Indication	Healthy	Red LED: Supply Healthy → Continuous ON, Phase Reverse → Flashing			
	UV	Red LED: Under Voltage → Continuous ON			
	OV	Red LED: Over Voltage → Continuous ON			
	Asymmetry	Red LED: Asymmetry → Continuous ON			
	All LED's	Phase Fail or Higher Cut OFF(> 560 VAC) or lower cut off (<175 VAC), Blinking → Pot changed during running conditions			
Operating Temperature		- 15° C to +60° C			
Storage Temperature		- 20° C to +80° C			
Humidity (Non Condensing)		95% (Rh)			
Enclosure		Flame Retardant UL 94-V0			
Dimension (W x H x D) (in mm)		18 X 59 X 90			
Weight (unpacked) Approx.		70 g			
Mounting		Base / DIN rail			
Degree of Protection		IP 20 for Terminal, IP 30 for Enclosure			
Certification		  			
EMI / EMC					
Harmonic Current Emissions		IEC 61000-3-2	Ed. 3.2 (2009-04) Class A		
ESD		IEC 61000-4-2	Ed. 2.0 (2008-12) Level III		
Radiated Susceptibility		IEC 61000-4-3	Ed. 3.2 (2010-04) Level III		
Electrical Fast Transients		IEC 61000-4-4	Ed. 3.0 (2012-04) Level IV		
Surges		IEC 61000-4-5	Ed. 2.0 (2005-11) Level IV		
Conducted Susceptibility		IEC 61000-4-6	Ed. 3.0 (2008-10) Level III		
Voltage Dips & Interruptions (AC)		IEC 61000-4-11	Ed. 2.0 (2004-03) All 7 Levels		
Conducted Emission		CISPR 14-1	Ed. 5.2 (20011-11) Class A		
Radiated Emission		CISPR 14-1	Ed. 5.2 (20011-11) Class B		
Environmental					
Cold Heat		IEC 60068-2-1	Ed. 6.0 (2007-03)		
Dry Heat		IEC 60068-2-2	Ed. 5.0 (2007-07)		
Vibration		IEC 60068-2-6	Ed. 7.0 (2007-12) 5g		
Repetitive Shock		IEC 60068-2-27	Ed. 4.0 (2008-02) 40g, 6ms		
Non-Repetitive Shock		IEC 60068-2-27	Ed. 4.0 (2008-02) 30g, 15ms		

ORDERING INFORMATION

Cat. No.	Description
MD21DF	208 - 480 VAC, UV / OV, Phase Loss & Sequence with Selectable ON Delay, 1 C/O
MG21DH	208 - 480 VAC, UV / OV & SPP with Selectable ON Delay, 1 C/O
MG21DF	208 - 480 VAC, UV / OV & SPP with Selectable OFF Delay, 1 C/O
MGD1DR	208 - 480 VAC, UV / OV & SPP with Selectable ON Delay & OFF Delay, 1 C/O
MAE03D0200	115 VAC/DC or 240 VAC/DC, UV / OV with Selectable ON & OFF Delay, 1 C/O



CONNECTION DIAGRAM

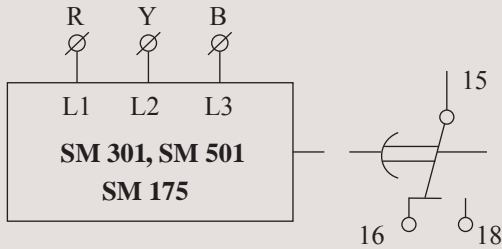

MA51BC, MA51BK, MN21D5, MK21D5, MC21D5
MA21DN, MD21DF, MG21DH, MG21DF, MGD1DR

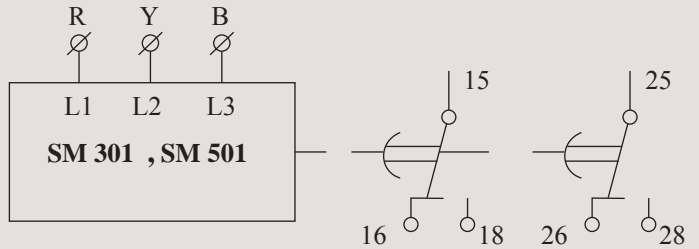

MG53BH, MG53BF, MG63BH, MG63BF
MG53BI, MG53BO, MB53BM, MC21B5

SINGLE PHASE

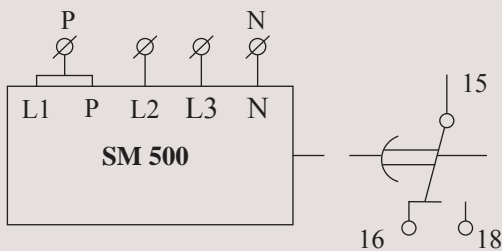

MD71BH, MD71BF, MD71B9

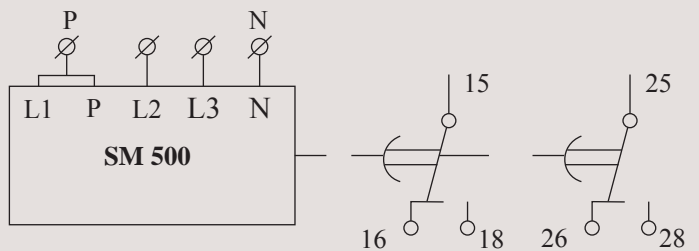

MG73BH, MG73BF, MG73B9

THREE PHASE

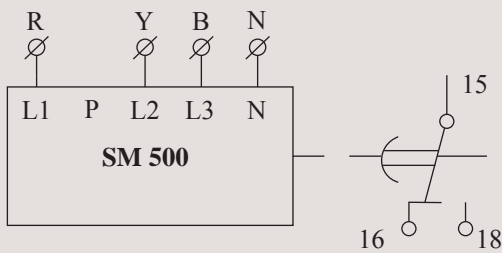

MD71BH, MD71BF, MD71B9

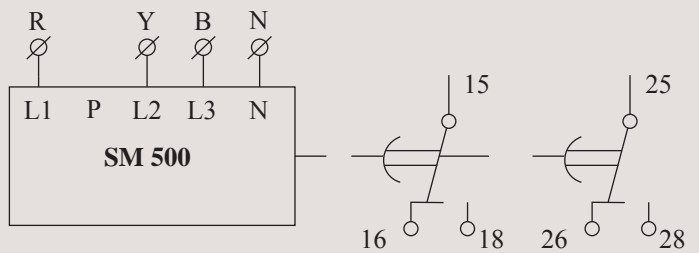



MG73BH, MG73BF, MG73B9, MAC04D0100 (P is not applicable in neutral loss)

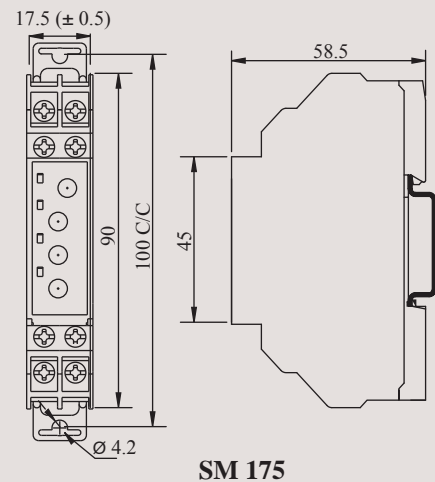
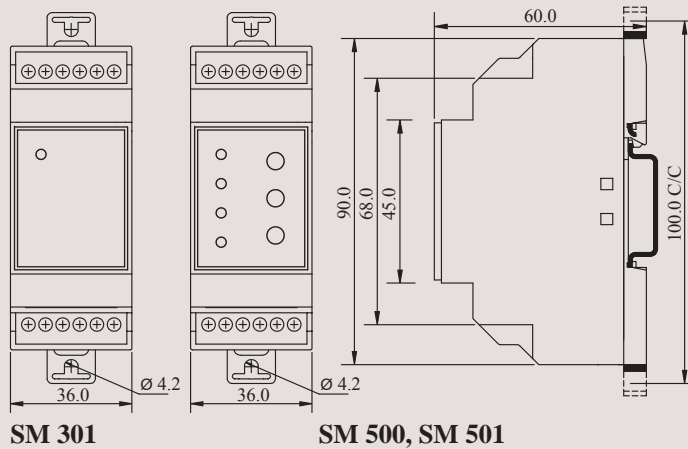

MOUNTING DIMENSION (mm)

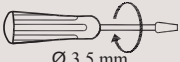

TERMINAL TORQUE & CAPACITY

 Ø 3.5 mm	Torque - 0.54 N.m (5 Lb.in) Terminal screw - M2.6
	Solid Wire - 1 X 0.2...3.3 mm ²
AWG	1 X 24 to 12

SM 301, SM 500, SM 501

 Ø 3.5...5.0 mm	Torque - 1.1 N.m (10 Lb.in) Terminal screw - M3.5
	Solid Wire - 2 X 0.2...2.5 mm ²
AWG	1 X 24 to 10

SM 175

Supply Monitoring Series - Three Phase Indicator

- Compact 17.5 mm Wide
- Available for Single, Two and Three Phase indications
- Choice of four colours
- LED technology for long life
- Integrated front product labeling



Cat. No.	MM1NDV	MMENDVW	MM3ND
Parameters			
Supply Voltage (φ)	240 VAC		
Supply Variation	-25 to +10% (of φ)		
Frequency	50/60Hz		
Power Consumption (Max.)	1.8 W		
Number of Indications	1	2	3
LED Colour	Red	R Phase	R Phase
	Yellow	N A	Y Phase
	Blue	N A	B Phase
LED Type	Through Hole (Water Clear)		
LED Size	3mm		
Operating Temperature	- 15° C to +60° C		
Storage Temperature	- 25° C to +80° C		
Humidity (Non Condensing)	95% (Rh)		
Enclosure	Flame Retardant UL94-V0		
Dimension (W x H x D) (in mm)	17.5 X 90 X 65		
Weight (unpacked)	75 g		
Mounting	Base / DIN rail		
Certification			
Degree of Protection	IP 20 for Terminals, IP 40 for Enclosure		
EMI / EMC			
Harmonic Current Emissions	IEC 61000-3-2	Ed. 3.2 (2009-04) Class A	
ESD	IEC 61000-4-2	Ed. 2.0 (2008-12) Level II	
Radiated Susceptibility	IEC 61000-4-3	Ed. 3.2 (2010-04) Level III	
Electrical Fast Transients	IEC 61000-4-4	Ed. 3.0 (2012-04) Level IV	
Surges	IEC 61000-4-5	Ed. 2.0 (2005-11) Level IV	
Conducted Susceptibility	IEC 61000-4-6	Ed. 3.0 (2008-10) Level III	
Voltage Dips & Interruptions (AC)	IEC 61000-4-11	Ed. 2.0 (2004-03) Level I, II, III, IV & V Class A, Level 6 Class B	
Conducted Emission	CISPR 14-1	Ed. 5.2 (20011-11) Class A	
Radiated Emission	CISPR 14-1	Ed. 5.2 (20011-11) Class A	
Environmental			
Cold Heat	IEC 60068-2-1	Ed. 6.0 (2007-03)	
Dry Heat	IEC 60068-2-2	Ed. 5.0 (2007-07)	
Vibration	IEC 60068-2-6	Ed. 7.0 (2007-12) 5g	
Repetitive Shock	IEC 60068-2-27	Ed. 4.0 (2008-02) 40g, 6ms	
Non-Repetitive Shock	IEC 60068-2-27	Ed. 4.0 (2008-02) 30g, 15ms	

ORDERING INFORMATION

Cat. No.	Description
MM1NDV	240V AC, Single Phase Indicator, Red
MM1NDW	240V AC, Single Phase Indicator, Yellow
MM1NDX	240V AC, Single Phase Indicator, Blue
MM1NDY	240V AC, Single Phase Indicator, Green
MMENDVW	240V AC, Two Phase Indicator, Red & Yellow
MM3ND	240V AC, Three Phase Indicator, Red, Yellow & Blue
MM3NDVH	240V AC, Three Phase Indicator, Red, Yellow & Green
MM3NDZ	240V AC, Three Phase Indicator, Green

MOUNTING DIMENSIONS (mm)

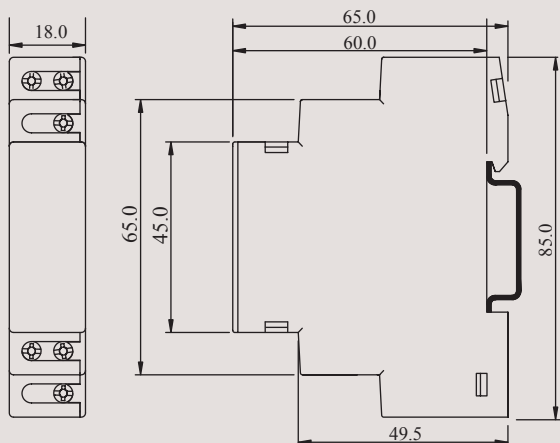



TERMINAL TORQUE & CAPACITY

 Torque - 0.6 N.m (6 Lb.in) Terminal screw - M3 Ø 3.5...4.0 mm	
 Solid Wire - 1 X 1...4 mm ²	
AWG	1 X 18 to 10

Frequency Monitoring Series PD 225

- Wide Auxiliary Supply voltage Range: 110 - 240 VAC, 220 - 440 VAC
- Models for Over Frequency and Under/Over Frequency Monitoring
- Monitors Frequency of Three signals - Sine, Square & Triangular
- Model for Frequency Limit Control: 5 Hz to 135 Hz
- Wide Signal Input Voltage: 15 to 500 VAC
- Adjustable Relay status in Healthy or Unhealthy condition using DIP switch "ET" (Energize to Trip) or "DT" (De-energize to trip.)
- Ease of Frequency setting with simple Addition & Subtraction
- LED Indications for Healthy, Unhealthy & No signal conditions



Cat. No.		MI81BJ	MI91BL
Parameters			
Supply Voltage (Φ)		110 - 240 VAC	220 - 440 VAC
Supply Variation		-15% to +15% (of Φ)	
Frequency		50/60 Hz	
Power Consumption (Max.)		3 VA	
Signal Type		Sinusoidal, Square, Triangular	
Signal Input Voltage Range		(15 to 500) V	
Overall Frequency Range		(5 to 135) Hz	(40 to 70) Hz
Trip Settings	Over Frequency	0.33 to 1 of Full Scale	(+1 to +10) Hz above Selected Value
	Under Frequency	N A	(-1 to -10) Hz below Selected Value
	Reset Hysteresis	1.5 % of Full Scale selected	
Setting Accuracy		± 5%	
Repeat Accuracy		± 0.02%	
Time Delay	ON Delay	500 ms	500 ms to 5 s
	OFF Delay	100 ms	
	Reset Time	150 ms	
Output	Relay Output	1 C/O	
	Contact Rating	6A (Resistive) @ 250 VAC / 28 VDC	
	Electrical Life	1 x 10 ⁶	
	Mechanical Life	3 x 10 ⁶	
Utilization Category	AC - 15	Rated Voltage (Ue): 120/240 V, Rated Current (Ie): 3.0/1.5 A	
	DC - 13	Rated Voltage (Ue): 24/125/250 V, Rated Current (Ie): 2.0/0.22/0.1 A	
LED Indications	Relay	Red LED Flashing if No Signal	N A
	UF / OF	N A	Separate for UF & OF
Operating Temperature		- 15° C to +60° C	
Storage Temperature		- 25° C to +80° C	
Enclosure		Flame Retardant UL94-V0	
Dimension (W x H x D) (in mm)		22.5 X 83 X 100.5	
Weight (unpacked)		120 g	
Mounting		Base / DIN rail	
Certification		  	
Degree of Protection		IP 20 for Terminals, IP 40 for Enclosure	
EMI / EMC			
Harmonic Current Emissions	IEC 61000-3-2	Ed. 3.2 (2009-04) Class A	
ESD	IEC 61000-4-2	Ed. 2.0 (2008-12) Level II	
Radiated Susceptibility	IEC 61000-4-3	Ed. 3.2 (2010-04) Level III	
Electrical Fast Transients	IEC 61000-4-4	Ed. 3.0 (2012-04) Level IV	
Surges	IEC 61000-4-5	Ed. 2.0 (2005-11) Level IV	
Conducted Susceptibility	IEC 61000-4-6	Ed. 3.0 (2008-10) Level III	
Voltage Dips & Interruptions (AC)	IEC 61000-4-11	Ed. 2.0 (2004-03) All 7 Levels	
Conducted Emission	CISPR 14-1	Ed. 5.2 (20011-11) Class A	
Radiated Emission	CISPR 14-1	Ed. 5.2 (20011-11) Class B	
Environmental			
Cold Heat	IEC 60068-2-1	Ed. 6.0 (2007-03)	
Dry Heat	IEC 60068-2-2	Ed. 5.0 (2007-07)	
Vibration	IEC 60068-2-6	Ed. 7.0 (2007-12) 5g	
Repetitive Shock	IEC 60068-2-27	Ed. 4.0 (2008-02) 40g, 6ms	
Non-Repetitive Shock	IEC 60068-2-27	Ed. 4.0 (2008-02) 30g, 15ms	

ORDERING INFORMATION

Cat. No.	Description
MI81BJ	110 - 240 VAC, Over Frequency Relay, 1 C/O
MI91BJ	220 - 440 VAC, Over Frequency Relay, 1 C/O
MI81BL	110 - 240 VAC, Over Frequency & Under Frequency Relay, 1 C/O
MI91BL	220 - 440 VAC, Over Frequency & Under Frequency Relay, 1 C/O

UL Approval for Cat Nos. MI81BL & MI91BL only.

PTC Thermistor Relay Series PD 225

- Monitors and Protects Motors with Integrated PTC Resistor sensors
- Protection against Over heating for Heavy Duty Load, High Switching Frequency, High operating temperature & Insufficient cooling conditions
- Wide Auxiliary Supply Voltage: 24 VAC/DC, 110 - 240 VAC & 220 - 415 VAC
- LED Indications for Healthy, Unhealthy, Sensor Open/Short conditions
- 1 C/O & 2 C/O Configuration
- Reset Options: Auto, Manual and Remote



Cat. No.		MJ83BK	MJ93BK	MJA3BK
Parameters				
Supply Voltage (φ)		110 - 240 VAC	220 - 440 VAC	24 VAC/DC
Supply Variation		-20% to + 10% (of φ)		
Frequency		50/60 Hz		
Power Consumption (Max.)		4 VA		2 VA
Trip Settings	Trip Level	2.7 kΩ, (± 5%)		
	Reset Level	1.71 kΩ, (± 5%)		
	Sensor Short	< 20Ω, (± 4Ω)		
	Hysterisis	40 Ω, (± 4Ω)		
	Sensor Open	> 20 kΩ, (± 5%)		
Max Cold Res(Ω) of Sensor Chain		< 1.5 kΩ		
Reset Mode		Auto, Manual, Remote		
Repeat Accuracy		1%		
Time Delay	ON Delay	500 ms		
	OFF Delay	100 ms		
	Reset Time	150 ms		
Output	Relay Output	2 C/O	2 C/O	2 C/O
	Contact Rating	5A (Resistive) @ 250 VAC / 28 VDC		
	Electrical Life	1 x 10 ⁷		
	Mechanical Life	3 x 10 ⁶		
Utilization Category	AC - 15	Rated Voltage (Ue): 120/240 V, Rated Current (Ie): 3.0/1.5 A		
	DC - 13	Rated Voltage (Ue): 24/125/250 V, Rated Current (Ie): 2.0/0.22/0.1 A		
LED Indications	Green LED	Continuous ON → Healthy	Flashing → Sensor Open	
	Red LED	Continuous ON → Relay ON	Flashing → Sensor Short	
	All LEDs OFF	Power Supply Fail		
Operating Temperature		- 15° C to +60° C		
Storage Temperature		- 25° C to +80° C		
Humidity (Non Condensing)		95% (Rh)		
Enclosure		Flame Retardant UL94-V0		
Dimension (W x H x D) (in mm)		22.5 X 83 X 100.5		
Weight (unpacked)		120 g		
Mounting		Base / DIN rail		
Certification		  		
Degree of Protection		IP 20 for Terminals, IP 40 for Enclosure		
EMI / EMC				
Harmonic Current Emissions		IEC 61000-3-2	Ed. 3.2 (2009-04) Class A	
ESD		IEC 61000-4-2	Ed. 2.0 (2008-12) Level II	
Radiated Susceptibility		IEC 61000-4-3	Ed. 3.2 (2010-04) Level III	
Electrical Fast Transients		IEC 61000-4-4	Ed. 3.0 (2012-04) Level IV	
Surges		IEC 61000-4-5	Ed. 2.0 (2005-11) Level IV	
Conducted Susceptibility		IEC 61000-4-6	Ed. 3.0 (2008-10) Level III	
Voltage Dips & Interruptions (AC)		IEC 61000-4-11	Ed. 2.0 (2004-03) All 7 Levels	
Voltage Dips & Interruptions (DC)		IEC 61000-4-29	Ed. 1.0 (2000-08) All 5 Levels	
Conducted Emission		CISPR 14-1	Ed. 5.2 (20011-11) Class B	
Radiated Emission		CISPR 14-1	Ed. 5.2 (20011-11) Class B	
Environmental				
Cold Heat		IEC 60068-2-1	Ed. 6.0 (2007-03)	
Dry Heat		IEC 60068-2-2	Ed. 5.0 (2007-07)	
Vibration		IEC 60068-2-6	Ed. 7.0 (2007-12) 5g	
Repetitive Shock		IEC 60068-2-27	Ed. 4.0 (2008-02) 40g, 6ms	
Non-Repetitive Shock		IEC 60068-2-27	Ed. 4.0 (2008-02) 30g, 15ms	

ORDERING INFORMATION



Cat. No.	Description
MJ83BK	110 - 240 VAC, PTC Thermistor Relay, 2 C/O
MJ93BK	220 - 440 VAC, PTC Thermistor Relay, 2 C/O
MJA3BK	24 VAC/DC, PTC Thermistor Relay, 2 C/O
MJ81BK	110 - 240 VAC, PTC Thermistor Relay, 1 C/O
MJ91BK	220 - 440 VAC, PTC Thermistor Relay, 1 C/O

UL Approval not applicable for Cat Nos. MJ83BK & MJ93BK.

PTC Thermistor & Single Phasing Preventer Series PD225

- Thermistor Relay combined with Protection against Phase Sequence, Phase Loss & Phase Asymmetry Faults
- Monitors and Protects Motors with Integrated PTC Resistor sensors
- Protection against Over heating for Heavy Duty Load, High Switching Frequency, High operating temperature & Insufficient cooling conditions
- LED indications for Healthy, Unhealthy, Sensor Open/Short and Phase Sequence fault conditions



Cat. No.		ML64BS	MLD7BS
Parameters			
Supply Voltage (φ)		230 VAC (3 Phase 3 Wire)	400 VAC (3 Phase 3 Wire)
Supply Variation		-15% to + 15% (of φ)	-15% to + 15% (of φ)
Frequency		50/60 Hz	50/60 Hz
Power Consumption (Max.)		15 VA	24 VA
Trip Settings	Trip Level	2.7 kΩ, (± 5%)	
	Reset Level	1.71 kΩ, (± 5%)	
	Sensor Short	< 20Ω, (± 4Ω)	
	Hysteresis	40 Ω, (± 4Ω)	
	Sensor Open	> 20 kΩ, (± 5%)	
Max Cold Res(Ω) of Sensor Chain		< 1.5 kΩ	
Cable Resistance		20 Ω	
Phase Asymmetry		70 VAC (± 10 VAC)	104 VAC (± 10 VAC)
Asymmetrical Phase Loss		110 VAC (± 10 VAC)	220 VAC (± 10 VAC)
Symmetrical Phase Loss		130 VAC (± 10 VAC)	240 VAC (± 10 VAC)
Restart Voltage		145 VAC (± 10 VAC)	265 VAC (± 10 VAC)
Reset Mode		Auto	
Repeat Accuracy		1%	
Time Delay	Operate Time	< 350 ms	
	Release Time	360 - 550ms for Asymmetrical or Symmetrical Phase Fault & 100ms (max.) for Phase Sequence, Thermistor Trip	
	Reset Time	100 - 750 ms	
Output	Relay Output	1 NO (SPP) + 1 NO (PTC Thermistor)	1 NO (SPP) + 1 NC (PTC Thermistor)
	Contact Rating	5A 'NO' & 3A 'NC' @ 240 VAC / 28 VDC (Resistive)	
	Electrical Life	1 x 10 ⁵	
	Mechanical Life	3 x 10 ⁷	
Utilization Category	AC - 15	Rated Voltage (Ue): 120/240 V, Rated Current (Ie): 3.0/1.5 A	
	DC - 13	Rated Voltage (Ue): 24/125/250 V, Rated Current (Ie): 2.0/0.22/0.1 A	
LED Indications	(Green)	Continuous ON	Power Supply Healthy
		Continuous OFF	Power Fail
		Flashing	Sensor Open
	(Amber)	Continuous ON	Over Temperature Trip
		Continuous OFF	Thermistor Relay ON
		Flashing	Sensor Short or Cable Short
(Red)	Continuous ON	SPP Relay Trip (For Supply Above Restart Voltage)	
	Continuous OFF	SPP Relay ON (After ensuring the input Voltage of 5V above the Restart Voltage)	
Flashing	Supply & SPP Fault below restart voltage		
Operating Temperature		- 10° C to +60° C	
Storage Temperature		- 15° C to +70° C	
Humidity (Non Condensing)		95% (Rh)	
Enclosure		Flame Retardant UL94-V0	
Dimension (W x H x D) (in mm)		22.5 X 83 X 100.5	
Weight (unpacked)		150 g	
Mounting		Base / DIN rail	
Certification		 	
Degree of Protection		IP 20 for Terminals, IP 40 for Enclosure	
EMI / EMC			
Harmonic Current Emissions		IEC 61000-3-2	Ed. 3.2 (2009-04) Class A
ESD		IEC 61000-4-2	Ed. 2.0 (2008-12) Level II
Radiated Susceptibility		IEC 61000-4-3	Ed. 3.2 (2010-04) Level III
Electrical Fast Transients		IEC 61000-4-4	Ed. 3.0 (2012-04) Level IV
Surges		IEC 61000-4-5	Ed. 2.0 (2005-11) Level IV
Conducted Susceptibility		IEC 61000-4-6	Ed. 3.0 (2008-10) Level III
Voltage Dips & Interruptions (AC)		IEC 61000-4-11	Ed. 2.0 (2004-03) All 7 Levels
Conducted Emission		CISPR 14-1	Ed. 5.2 (2011-11) Class A
Radiated Emission		CISPR 14-1	Ed. 5.2 (2011-11) Class A
Environmental			
Cold Heat		IEC 60068-2-1	Ed. 6.0 (2007-03)
Dry Heat		IEC 60068-2-2	Ed. 5.0 (2007-07)
Vibration		IEC 60068-2-6	Ed. 7.0 (2007-12) 5g
Repetitive Shock		IEC 60068-2-27	Ed. 4.0 (2008-02) 40g, 6ms
Non-Repetitive Shock		IEC 60068-2-27	Ed. 4.0 (2008-02) 30g, 15ms

ORDERING INFORMATION

Cat. No.	Description
ML64BS	230 VAC, PTC Thermistor & Single Phasing Preventer, 1 NO + 1 NO
ML67BS	230 VAC, PTC Thermistor & Single Phasing Preventer, 1 NO + 1 NC
MLD4BS	400 VAC, PTC Thermistor & Single Phasing Preventer, 1 NO + 1 NO
MLD7BS	400 VAC, PTC Thermistor & Single Phasing Preventer, 1 NO + 1 NC

MOUNTING DIMENSION (mm)

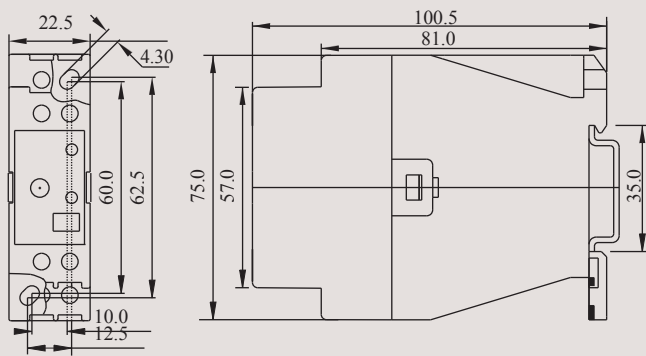

FREQUENCY MONITORING SERIES PD 225

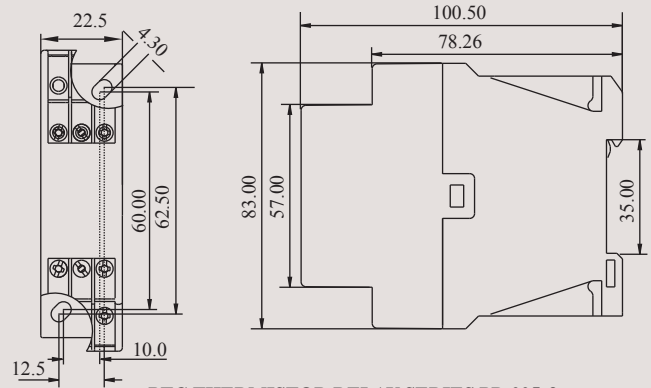

PTC THERMISTOR RELAY SERIES PD 225 &
PTC THERMISTOR & SINGLE PHASING PREVENTER SERIES PD 225

CONNECTION DIAGRAM

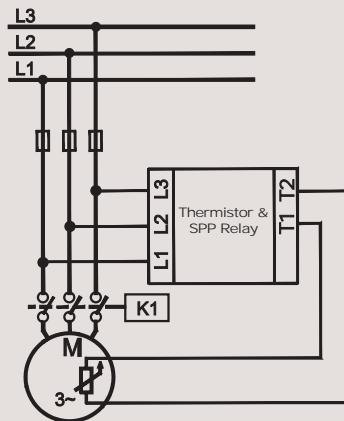

PTC THERMISTOR & SINGLE PHASING PREVENTER SERIES PD 225

CONTACT ARRANGEMENT :

For 1 NO + 1 NO PRODUCT:
ML64BS, MLD4BS

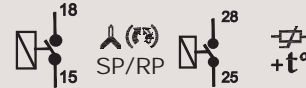

For 1 NO + 1 NC PRODUCT:
ML67BS, MLD7BS

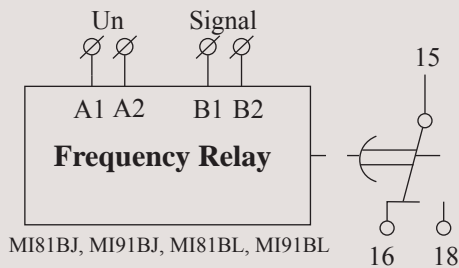

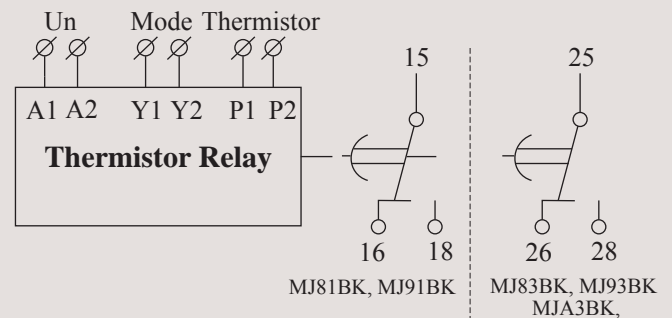

FREQUENCY MONITORING SERIES PD 225

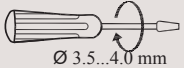

PTC THERMISTOR RELAY SERIES PD 225

TERMINAL TORQUE & CAPACITY

 Ø 3.5...4.0 mm	Torque - 0.6 N.m (6 Lb.in) Terminal screw - M3
	Solid Wire - 1 X 1...6 mm ²
AWG	1 X 20 to 12

FREQUENCY MONITORING SERIES PD 225



PTC THERMISTOR RELAY SERIES PD 225

PTC THERMISTOR & SINGLE PHASING PREVENTER SERIES PD 225

Supply Monitoring Series CMR - Current Control

- Protects against Overload, Phase Reverse, Phase Loss and Phase Unbalance faults
- Wide Range of Sensing Current : 1A-45A
- Models for 1 Phase and 3 Phase systems
- Auto/Manual Reset selection
- Fail-Safe Protection
- Inverse Time model with Underload, Locked Rotor Protection and Selectable Trip Class
- Definite Time model with Underload and selectable Start and Trip time





Cat. No.		17C112EB0	17C212EB0	17D312DA0	17D112LA0
Parameters					
Supply Voltage (φ)		110 - 240 VAC			
Supply Variation		-20% to +10% of (φ)			
Frequency		50 / 60 Hz			
Power Consumption (Max.)		5 VA			
Trip Settings	Trip Type	Inverse Time	Inverse Time	Definite Time	Definite Time
	Tripping Class	5, 10, 20, 30	5, 10, 20, 30	N A	N A
	Current Ranges	3 - 9 A	8 - 24 A	15 - 45 A	3 - 9 A
	Thermal Memory	Yes	Yes	N A	N A
	Underload	40% to 90%	40% to 90%	50%	50%
	Locked Rotor Protection	400% of the set value	400% of the set value	N A	N A
Number of In-Built CT's		1			
Reset Mode		Auto, Manual			
Test Function		Yes			
Time Delay	Start Time	N A	N A	0.2 to 30s	0.2 to 30s
	Delay Time	As per trip class	As per trip class	0.2 to 10s	2 to 10s
	Auto Reset Time	3-15 min (As per trip class)	3-15 min (As per trip class)	6 min	20 s
	ON Delay	60 ms to 700 ms			
Setting Accuracy		± 5%			
Repeat Accuracy		± 2%			
Output	Relay Output	1 C/O			
	Contact Rating	5A @ 240 VAC (Resistive)			
	Electrical Life	1 x 10 ⁵			
	Mechanical Life	1 x 10 ⁷			
Utilization Category	AC - 15	Rated Voltage (Ue): 120/240 V, Rated Current (Ie): 3.0/1.5 A			
LED Indications		ON: Power ON, UL: Underload, OL: Overload			
Operating Temperature		- 10° C to +60° C			
Storage Temperature		- 25° C to +70° C			
Humidity (Non Condensing)		95% (Rh)			
Enclosure		Flame Retardant UL94-V0			
Dimension (W x H x D) (in mm)		110 X 36.5 X 76.8			
Weight (unpacked) Approx.		210 g			
Mounting		Base Mounting			
Certification		 			
Degree of Protection		IP 20 for Enclosure			
EMI / EMC					
Harmonic Current Emissions		IEC 61000-3-2	Ed. 3.2 (2009-04) Class A		
ESD		IEC 61000-4-2	Ed. 2.0 (2008-12) Level II		
Radiated Susceptibility		IEC 61000-4-3	Ed. 3.2 (2010-04) Level III		
Electrical Fast Transients		IEC 61000-4-4	Ed. 3.0 (2012-04) Level IV		
Surges		IEC 61000-4-5	Ed. 2.0 (2005-11) Level IV		
Conducted Susceptibility		IEC 61000-4-6	Ed. 3.0 (2008-10) Level III		
Voltage Dips & Interruptions (AC)		IEC 61000-4-11	Ed. 2.0 (2004-03) Class A for All 7 Levels		
Conducted Emission		CISPR 14-1	Ed. 5.2 (20011-11) Class A		
Radiated Emission		CISPR 14-1	Ed. 5.2 (20011-11) Class A		
Environmental					
Cold Heat		IEC 60068-2-1	Ed. 6.0 (2007-03)		
Dry Heat		IEC 60068-2-2	Ed. 5.0 (2007-07)		
Vibration		IEC 60068-2-6	Ed. 7.0 (2007-12) 5g		
Repetitive Shock		IEC 60068-2-27	Ed. 4.0 (2008-02) 40g, 6ms		
Non-Repetitive Shock		IEC 60068-2-27	Ed. 4.0 (2008-02) 30g, 15ms		

ORDERING INFORMATION

Cat. No.	Trip Type	Current	Auto Reset Time
17C112EB0	Inverse	3 A - 9 A	As per trip class
17C212EB0	Inverse	8 A - 24 A	As per trip class
17C312EB0	Inverse	15 A - 45 A	As per trip class
17C412EB0	Inverse	2 A - 5 A	As per trip class
17D112DA0	Definite	3 A - 9 A	6 min
17D212DA0	Definite	8 A - 24 A	6 min
17D312DA0	Definite	15 A - 45 A	6 min
17D412DA0	Definite	2 A - 5 A	6 min

Supply Monitoring Series CMR - Current Control



Cat. No.		17A122CB0	17B222AA0	17A322CB0
Parameters				
Supply Voltage (φ)		220 - 415 VAC (3 Phase, 3 Wire)		
Supply Variation		-20% to +15% of (φ)		
Frequency		50/60 Hz		
Power Consumption (Max.)		12 VA		
Trip Settings	Trip Type	Inverse Time	Definite Time	Inverse Time
	Tripping Class	10A, 10, 20, 30	N A	10A, 10, 20, 30
	Current Ranges	3 - 9 A	8 - 24 A	15 - 45 A
	Thermal Memory	Yes	N A	Yes
	Phase Reverse Protection	Yes / (100 ms Approx.)		
	Phase Loss	70% of Unbalance		
	Current unbalance Protection	50% of Unbalance		
	Underload	40% to 90%	50%	40% to 90%
	Locked Rotor Protection	400% of the set value	N A	400% of the set value
Number of In-Built CT's		2		
Reset Mode		Auto, Manual		
Test Function		Yes		
Time Delay	Start Time	N A	0.2 to 30s	N A
	Delay Time	N A	0.2 to 10s	N A
	Auto Reset Time	3-15 min (As per trip class)	6 min	3-15 min (As per trip class)
	ON Delay	450 ms (±50ms)		
Setting Accuracy		± 5%		
Repeat Accuracy		± 2%		
Output	Relay Output	1 C/O		
	Contact Rating	5A @ 240 VAC (Resistive)		
	Electrical Life	1 x 10 ⁵		
	Mechanical Life	1 x 10 ⁷		
Utilization Category	AC - 15	Rated Voltage (Ue): 120/240 V, Rated Current (Ie): 3.0/1.5 A		
LED Indications		Separate indications for Phase Asymmetry, Phase Loss & Phase Sequence / Reverse, Power ON, Underload & Overload		
Operating Temperature		- 10° C to +60° C		
Storage Temperature		- 25° C to +70° C		
Humidity (Non Condensing)		95% (Rh)		
Enclosure		Flame Retardant UL94-V0		
Dimension (W x H x D) (in mm)		110 X 36.5 X 76.8		
Weight (unpacked) Approx.		210 g		
Mounting		Base Mounting		
Certification		 		
Degree of Protection		IP 20 for Enclosure		
EMI / EMC				
Harmonic Current Emissions		IEC 61000-3-2	Ed. 3.2 (2009-04) Class A	
ESD		IEC 61000-4-2	Ed. 2.0 (2008-12) Level II	
Radiated Susceptibility		IEC 61000-4-3	Ed. 3.2 (2010-04) Level III	
Electrical Fast Transients		IEC 61000-4-4	Ed. 3.0 (2012-04) Level IV	
Surges		IEC 61000-4-5	Ed. 2.0 (2005-11) Level IV	
Conducted Susceptibility		IEC 61000-4-6	Ed. 3.0 (2008-10) Level III	
Voltage Dips & Interruptions (AC)		IEC 61000-4-11	Ed. 2.0 (2004-03) Class A for All 7 Levels	
Conducted Emission		CISPR 14-1	Ed. 5.2 (20011-11) Class A	
Radiated Emission		CISPR 14-1	Ed. 5.2 (20011-11) Class A	
Environmental				
Cold Heat		IEC 60068-2-1	Ed. 6.0 (2007-03)	
Dry Heat		IEC 60068-2-2	Ed. 5.0 (2007-07)	
Vibration		IEC 60068-2-6	Ed. 7.0 (2007-12) 5g	
Repetitive Shock		IEC 60068-2-27	Ed. 4.0 (2008-02) 40g, 6ms	
Non-Repetitive Shock		IEC 60068-2-27	Ed. 4.0 (2008-02) 30g, 15ms	

ORDERING INFORMATION

Cat. No.	Trip Type	Current	Auto Reset Time
17A122CB0	Inverse	3 A - 9 A	As per trip class
17A222CB0	Inverse	8 A - 24 A	As per trip class
17A322CB0	Inverse	15 A - 45 A	As per trip class
17A422CB0	Inverse	2 A - 5 A	As per trip class
17B122AA0	Definite	3 A - 9 A	6 min
17B222AA0	Definite	8 A - 24 A	6 min
17B322AA0	Definite	15 A - 45 A	6 min
17B422AA0	Definite	2 A - 5 A	6 min

Note: 2 A - 5 A products can be used with external CT. Load wires to be passed through the external CT and Secondary's wire terminals are to be looped through the Product CT.

Supply Monitoring Series CMR - Current Control

MOUNTING DIMENSION (mm)

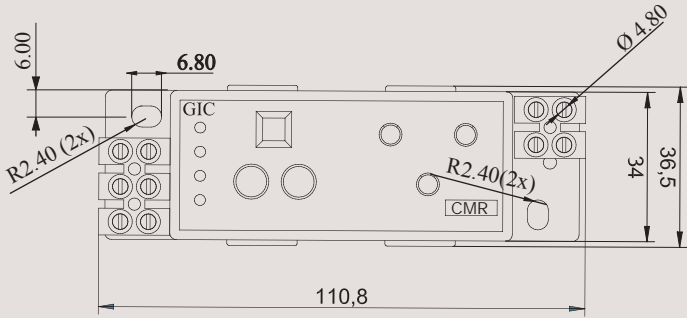

RELAY CONNECTION DIAGRAM

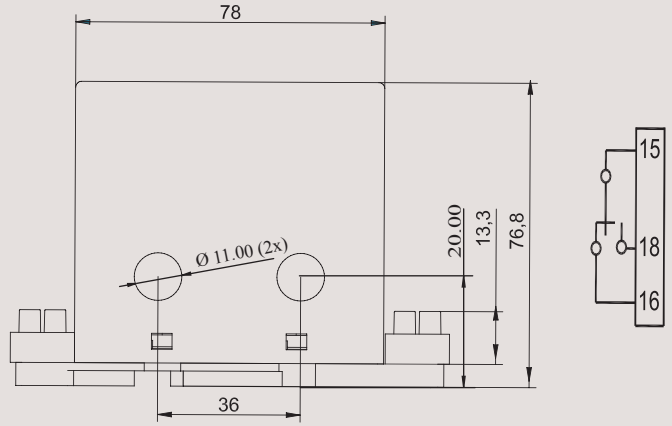

CONNECTION DIAGRAM

SINGLE PHASE

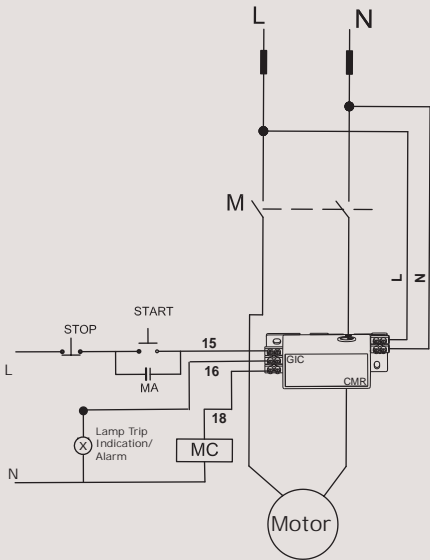

MANUAL RESET

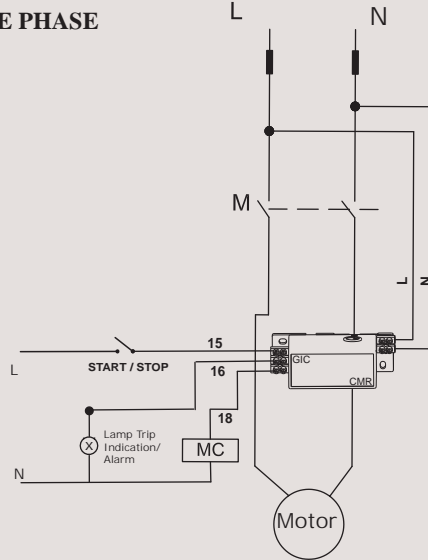

AUTO RESET

THREE PHASE

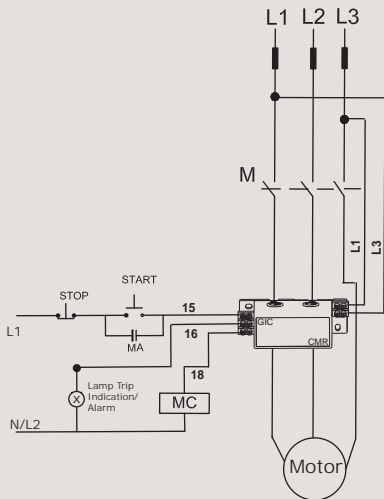

MANUAL RESET

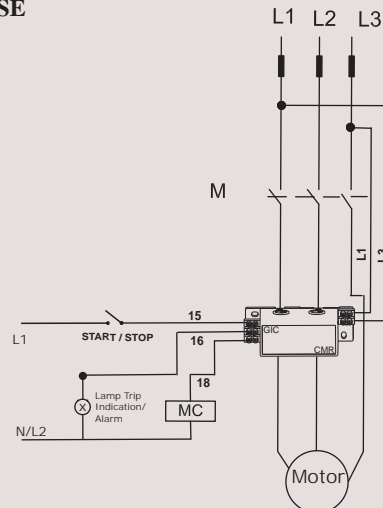

AUTO RESET

Earth Leakage Relay Series CMR

- Monitors, Detects and Protects Power systems from Earth Leakage Faults
- Wide range of selectable Earth Leakage Current: 30 mA - 30 A
- Configurable Earth Leakage Trip time: 0 - 10 s
- Wide Auxiliary Supply Range: 110 - 240 VAC, 220 - 415 VAC
- Instantaneous Trip for 5 times of set value of Leakage current
- Test feature to check complete product functionality
- LED Indication for Relay status, CT open, Earth Leakage fault & Test/Reset switch feature
- Manual / Remote Reset feature
- 1 C/O + 1 NO Relay Output



Cat. No.	17G715GF2	17G715KF2	17G745GF2	17G745KF2
Parameters				
Supply Voltage (φ)	110 - 240 VAC		220 - 415 VAC	
Supply Variation	-20 to +20%			
Frequency	50/60Hz			
Power Consumption (Max.)	5 VA		10 VA	
Leakage Current Range (ΔI n)	30 mA to 30 A			
Threshold IΔn (A)	0.03 - 0.1 - 0.3 - 0.5 - 1 - 3 - 5 - 10 - 20 - 30			
Type Class	'A' True RMS measurement (As per IEC 60947-2 appendix M)			
Max. Crest Factor	5 (for 30 mA to 30 A)			
Reset Mode	Manual Reset	Auto Reset	Manual Reset	Auto Reset
No. of Resets	N A	4	N A	4
Clear Auto Reset	After 1 hour of healthy condition or supply interruption			
Reset Enable & Reset Time	Below 50% on current threshold set by potentiometer & in presence of CBCT (< 1s)			
Trip Time (Δt in sec)	0.04 - 0.06 - 0.15 - 0.25 - 0.5 - 0.8 - 1 - 2.5 - 5 - 10			
Test / Reset	Local & Remote (Non Potential free contacts, upto 10 m)			
Setting Accuracy	-20% (Including CBCT Accuracy)			
Repeat Accuracy	± 2%			
Output	Relay Output	1 C/O + 1 NO		
	Contact Rating	5A (Resistive) @ 240 VAC / 30 VDC		
	Electrical Life	1 x 10 ⁵		
	Mechanical Life	1 x 10 ⁷		
Utilization Category	AC - 15	Rated Voltage (Ue): 120/240 V, Rated Current (Ie): 3.0/1.5 A		
	DC - 13	Rated Voltage (Ue): 24/125/250 V, Rated Current (Ie): 2.0/0.22/0.1 A		
LED Indication	Power	Green LED (ON)		
	EL / CT	Red LED (ON) → Relay Trip / Red LED (Blinking) → CT Open		
	Leakage Current / TST	By Bar Graph: 30% (Green), 45% (Green), 60% (Yellow), 75% (Red), Blink Test / Reset Switch is pressed		
Operating Temperature	- 15° C to +60° C			
Storage Temperature	- 25° C to +80° C			
Humidity (Non Condensing)	95% (Rh)			
Enclosure	Flame Retardant UL94-V0			
Dimension (W x H x D) (in mm)	36 X 90 X 65			
Weight (unpacked) Approx.	150 g			
Mounting	Base / DIN rail			
Certification				
Degree of Protection	IP 20 for Terminals, IP 40 for Enclosure			
EMI / EMC				
Harmonic Current Emissions	IEC 61000-3-2	Ed. 3.2 (2009-04) Class A		
ESD	IEC 61000-4-2	Ed. 2.0 (2008-12) Level II		
Radiated Susceptibility	IEC 61000-4-3	Ed. 3.2 (2010-04) Level III		
Electrical Fast Transients	IEC 61000-4-4	Ed. 3.0 (2012-04) Level IV		
Surges	IEC 61000-4-5	Ed. 2.0 (2005-11) Level IV		
Conducted Susceptibility	IEC 61000-4-6	Ed. 3.0 (2008-10) Level III		
Voltage Dips & Interruptions (AC)	IEC 61000-4-11	Ed. 2.0 (2004-03) Class A for Level I to V & Class B for Level VI & VII		
Conducted Emission	CISPR 14-1	Ed. 5.2 (2011-11) Class A		
Radiated Emission	CISPR 14-1	Ed. 5.2 (2011-11) Class A		
Environmental				
Cold Heat	IEC 60068-2-1	Ed. 6.0 (2007-03)		
Dry Heat	IEC 60068-2-2	Ed. 5.0 (2007-07)		
Vibration	IEC 60068-2-6	Ed. 7.0 (2007-12) 5g		
Repetitive Shock	IEC 60068-2-27	Ed. 4.0 (2008-02) 40g, 6ms		
Non-Repetitive Shock	IEC 60068-2-27	Ed. 4.0 (2008-02) 30g, 15ms		

ORDERING INFORMATION

Cat. No.	Description
17G715GF2	110-240V AC, Current Range 30 mA - 30 A, 1 C/O + 1 NO, Manual Reset
17G715KF2	110-240V AC, Current Range 30 mA - 30 A, 1 C/O + 1 NO, Auto Reset
17G745GF2	220-415V AC, Current Range 30 mA - 30 A, 1 C/O + 1 NO, Manual Reset
17G745KF2	220-415V AC, Current Range 30 mA - 30 A, 1 C/O + 1 NO, Auto Reset
17G755GF2	15V DC, Current Range 30 mA - 30 A, 1 C/O + 1 NO, Manual Reset
17G755KF2	15V DC, Current Range 30 mA - 30 A, 1 C/O + 1 NO, Auto Reset
17H7NNHN3	CBCT 38mm, 30 mA - 30A
17H7NNIN3	CBCT 57mm, 30 mA - 30A
17H7NNJN3	CBCT 92mm, 30 mA - 30A
17H7NNKN3	CBCT 215mm, 30 mA - 30A (Tape wound, 17 x 215 x 244 mm)

Earth Leakage Relay Series CMR



CONNECTION DIAGRAM

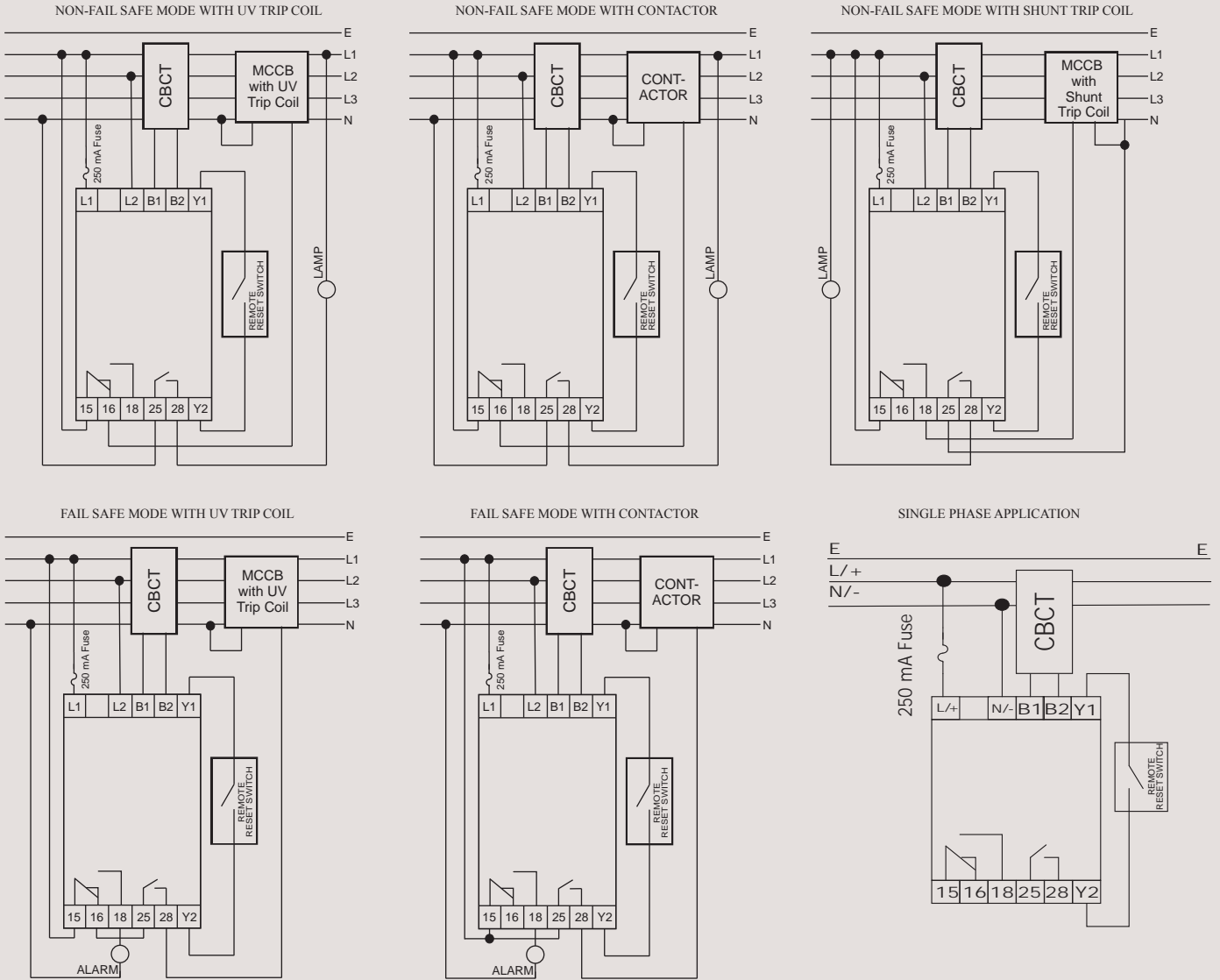

TERMINAL TORQUE & CAPACITY

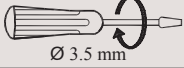
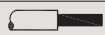
 Ø 3.5 mm	Torque - 0.54 N.m (5 Lb.in) Terminal screw - M2.6
	Solid Wire - 1 X 0.2...3.3 mm ²
AWG	1 X 24 to 12

MOUNTING DIMENSIONS

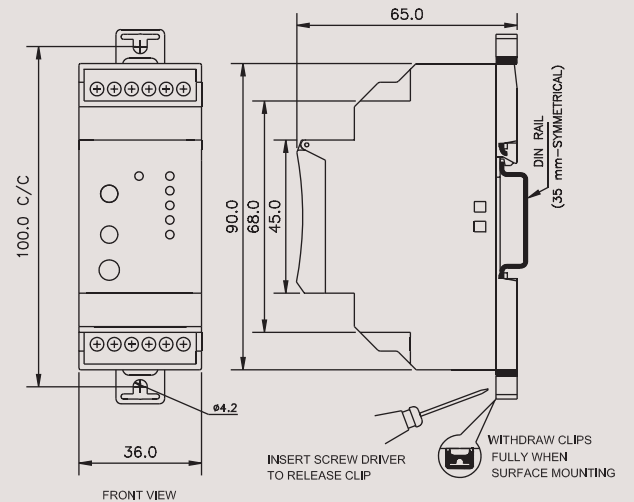

Earth Leakage Relay Series CMR

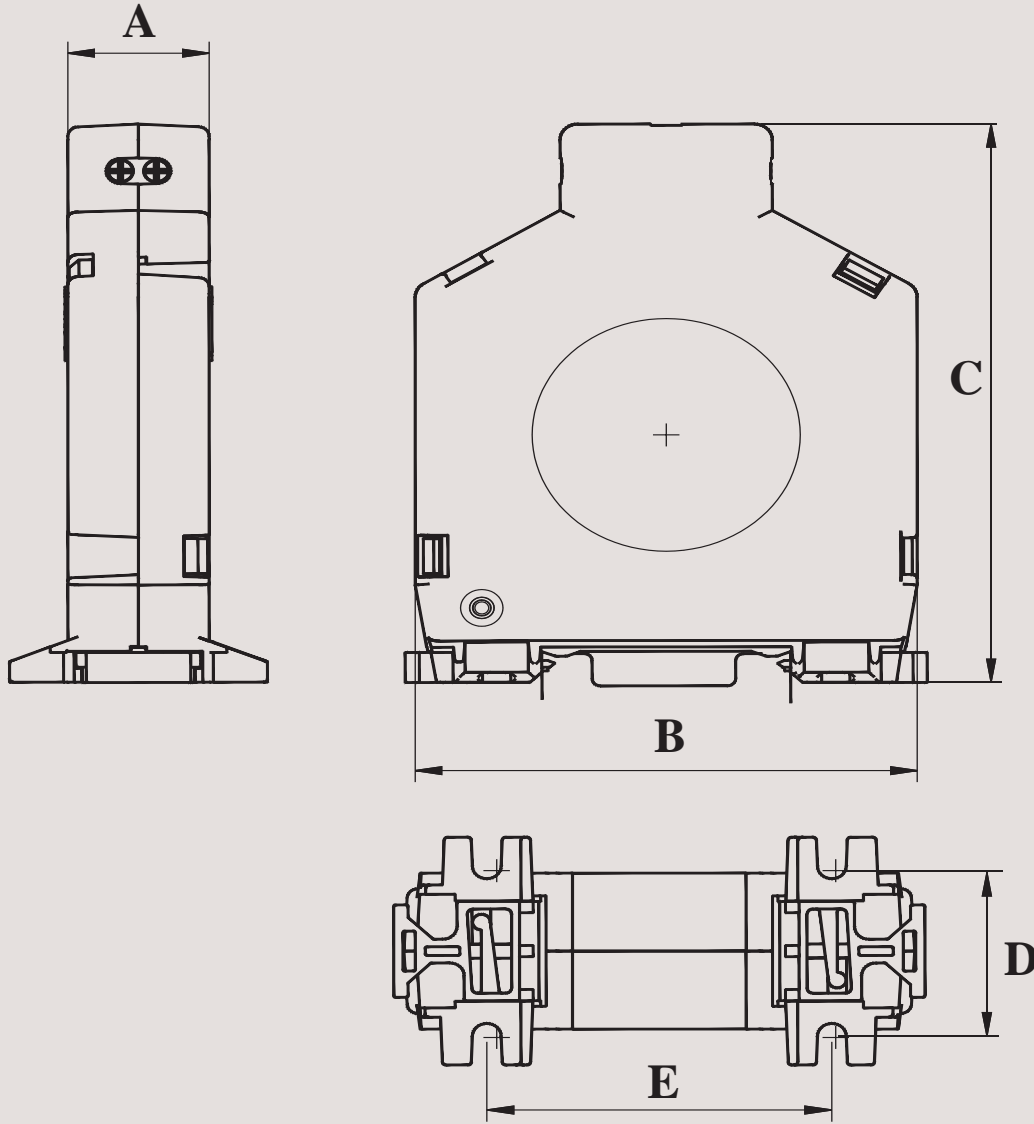

CBCT	SIZE	WEIGHT (in gms)	A	B	C	D	E
17H7NNHN3	38	110	20	71	91	27	48
17H7NNIN3	57	185	20	97	117	27	55
17H7NNJN3	92	250	20	132	155	27	73
17H7NNKN3	215	260	-	-	-	-	-

Dimensions in mm

Earth Leakage Relay Series CMR

- Monitors, Detects and Protects Power systems from Leakage faults
- Wide Auxiliary Supply range: 110 - 240 VAC, 220 - 415 VAC
- Wide Range of selectable Earth Leakage Current: 60 mA - 300 mA, 0.2A - 1.2A
- Configurable Earth Leakage Trip time: 100 ms - 5 s
- Easily configurable operating modes
- Test feature to check complete product functionality
- Manual / Remote reset feature
- LED indication for Relay status, CT open, Earth leakage fault & Test/Reset switch feature



Cat. No.	17G514FF1	17G614FF1	17G544FF1	17G644FF1
Parameters				
Supply Voltage (φ)	110 - 240 VAC		220 - 415 VAC	
Supply Variation	-20 to +10%			
Frequency	50/60Hz			
Power Consumption (Max.)	5 VA		10 VA	
Leakage Current Range	60 mA to 0.3 A	0.2 A to 1.2 A	60 mA to 0.3 A	0.2 A to 1.2 A
Mode	Fail Safe Latch (FSL), Fail Safe Non Latch (FSNL), Non Fail Safe Non Latch (NFSNL)			
Trip Time (Δt in sec)	0.1 - 0.2 - 0.4 - 2 - 5			
Trip Time (For 5 In)	100 ms (Irrespective of the Set Trip Time)			
Test / Reset	Local & Remote (For Fail Safe Latch mode only)			
Reset Enabled	Below 85% of Current sensitivity level and in presence of CBCT			
Reset Time	< 100 ms			
ON Delay	50 ms (± 20 ms)			
Setting Accuracy	-10% (85ms to 100 ms trip time for 100 ms setting in NFSNL)			
Repeat Accuracy	± 2%			
Output	Relay Output	1 C/O		
	Contact Rating	5A (Resistive) @ 240 VAC / 30 VDC		
	Electrical Life	1 x 10 ⁵		
	Mechanical Life	1 x 10 ⁷		
Utilization Category	AC - 15	Rated Voltage (Ue): 120/240 V, Rated Current (Ie): 3.0/1.5 A		
	DC - 13	Rated Voltage (Ue): 24/125/250 V, Rated Current (Ie): 2.0/0.22/0.1 A		
LED Indication	Power ON	Green LED (ON)		
	CT Open / SW Short	Red LED: ON → CT Open, Blink → TST / RST Switch short		
	Earth Leakage	Red LED: ON		
Operating Temperature	- 15° C to +60° C			
Storage Temperature	- 20° C to +80° C			
Humidity (Non Condensing)	95% (Rh)			
Enclosure	Flame Retardant UL94V0			
Dimension (W x H x D) (in mm)	22.5 X 83 X 100.5			
Weight (unpacked)	110 g			
Mounting	Base / DIN rail			
Certification				
Degree of Protection	IP 20 for Terminals, IP 40 for Enclosure			
EMI / EMC				
Harmonic Current Emissions	IEC 61000-3-2	Ed. 3.2 (2009-04) Class A		
ESD	IEC 61000-4-2	Ed. 2.0 (2008-12) Level II		
Radiated Susceptibility	IEC 61000-4-3	Ed. 3.2 (2010-04) Level III		
Electrical Fast Transients	IEC 61000-4-4	Ed. 3.0 (2012-04) Level IV		
Surges	IEC 61000-4-5	Ed. 2.0 (2005-11) Level IV		
Conducted Susceptibility	IEC 61000-4-6	Ed. 3.0 (2008-10) Level III		
Voltage Dips & Interruptions (AC)	IEC 61000-4-11	Ed. 2.0 (2004-03) Class A for Level I, II, IV & V & Class B for Level III, VI & VII		
Conducted Emission	CISPR 14-1	Ed. 5.2 (2011-11) Class A		
Radiated Emission	CISPR 14-1	Ed. 5.2 (2011-11) Class A		
Environmental				
Cold Heat	IEC 60068-2-1	Ed. 6.0 (2007-03)		
Dry Heat	IEC 60068-2-2	Ed. 5.0 (2007-07)		
Vibration	IEC 60068-2-6	Ed. 7.0 (2007-12) 5g		
Repetitive Shock	IEC 60068-2-27	Ed. 4.0 (2008-02) 40g, 6ms		
Non-Repetitive Shock	IEC 60068-2-27	Ed. 4.0 (2008-02) 30g, 15ms		

ORDERING INFORMATION

Cat. No.	Description
17G514FF1	110 - 240V AC, Earth Leakage Relay, Current Range 60 mA - 300 mA, 1 C/O
17G614FF1	110 - 240V AC, Earth Leakage Relay, Current Range 0.2 A-1.2 A, 1 C/O
17G544FF1	220 - 415V AC, Earth Leakage Relay, Current Range 60 mA - 300 mA, 1 C/O
17G644FF1	220 - 415V AC, Earth Leakage Relay, Current Range 0.2 A-1.2 A, 1 C/O
17H5NNHL3	CBCT (tape wound), 35mm, 60 mA - 300 mA
17H5NNIL3	CBCT (tape wound), 65mm, 60 mA - 300 mA
17H5NNJL3	CBCT (tape wound), 100mm, 60 mA - 300 mA
17H6NNHL3	CBCT (tape wound), 35mm, 0.2 A - 1.2 A
17H6NNIL3	CBCT (tape wound), 65mm, 0.2 A - 1.2 A
17H6NNJL3	CBCT (tape wound), 100mm, 0.2 A - 1.2 A

UL Approval for Cat. Nos. 17G514FF1 & 17G614FF1 only.

Earth Leakage Relay Series CMR



CONNECTION DIAGRAM

1) EARTH LEAKAGE RELAY WITH CONTACTOR FAILSAFE NON LATCH MODE

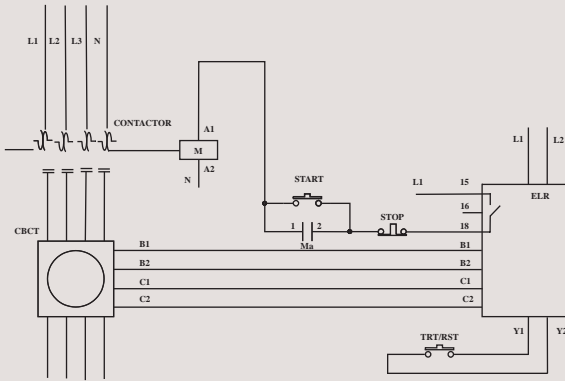

2) EARTH LEAKAGE RELAY WITH CONTACTOR FAIL SAFE LATCH MODE

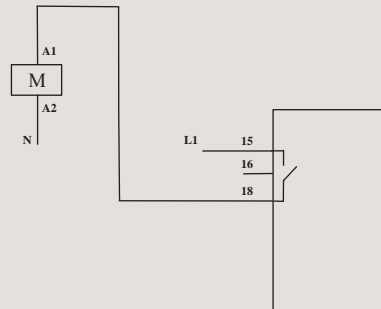

3) EARTH LEAKAGE RELAY WITH MCCB AND SHUNT TRIP COIL NON FAIL SAFE NON LATCH MODE

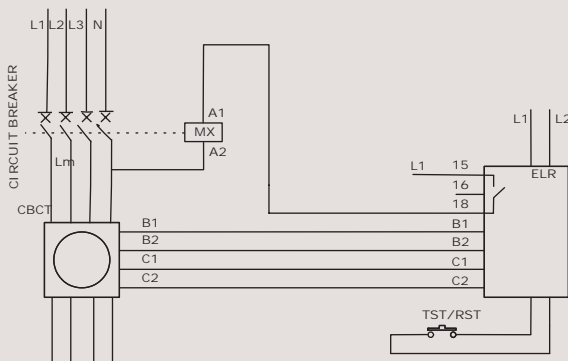

4) EARTH LEAKAGE RELAY WITH MCCB & UNDER VOLTAGE TRIP COIL FAIL SAFE LATCH MODE

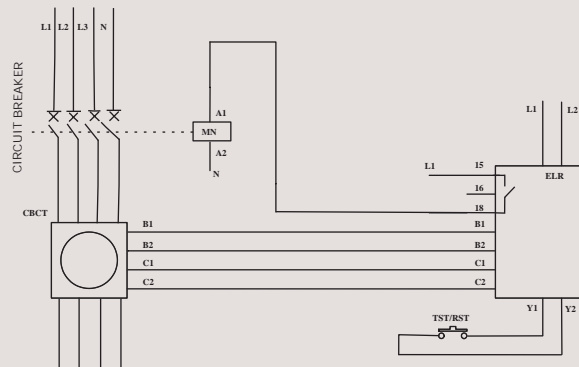

5) EARTH LEAKAGE RELAY WITH MCCB & UNDER VOLTAGE TRIP COIL FAIL SAFE NON-LATCH MODE

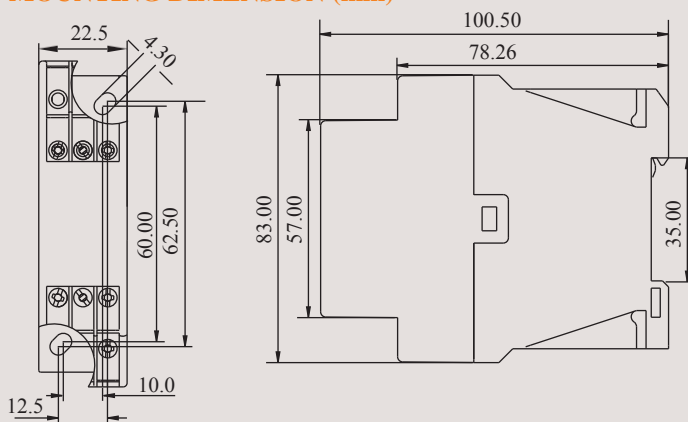

MOUNTING DIMENSION (mm)

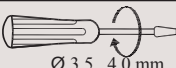

TERMINAL TORQUE & CAPACITY

 Ø 3.5...4.0 mm	Torque - 0.6 N.m (6 Lb.in) Terminal screw - M3
	Solid Wire - 1 X 1...6 mm ²
AWG	1 X 20 to 12

TEMPERATURE CONTROLLERS

PID Temperature Controller Series PR 69

ON-OFF Temperature Controller Series PR 433 & PR 434

PID Temperature Controller Series PR 69

- Universal Input
- Configurable Output combination
- Configurable: Band, Deviation, Sensor break & Loop break alarms
- Single/Dual acting PID controllers with 5 Control modes
- Auto-tuning PID with provision for Soft-Start
- 6 Segment Ramp & Soak profile with Power Failure resumption modes
- Rapid Set Point change feature
- RS 485 Communication
- Bumpless Auto-Manual transfer
- IP 20 (for Terminal & Enclosure)
IP 40 (for for Front Panel only)



Cat. No.	151A13B1	151B13B1	151C13B1	151D13B1
Parameters				
Supply Voltage (ϕ)	110 - 240 VAC			
Supply Variation	-20% to +10% (of ϕ)			
Frequency	50/60 Hz			
Control Action	ON/OFF (Symmetric / Asymmetric), PID (Single / Dual Acting)			
Tuning Method	Auto Tuning / Manual Tuning			
Temperature sensors / Inputs	Thermocouple: J, K, E, S, B, R; RTD: PT100 - 3 wire compensation; Analog Signal: (0-50 mV, 0-60 mV, 12-60 mV)			
Measurement Range	Sensor J: 0 to 700°C/32 to 1292°F, Sensor K: 0 to 1300°C/32 to 2372°F, Sensor E: 0 to 600°C/32 to 1112°F, Sensor R: 0 to 1750°C/32 to 3182°F, Sensor S: 0 to 1750°C/32 to 3182°F, Sensor B: 250 to 1820°C/482 to 3308°F, Sensor PT100 3 wire: - 200 to 700°C/-328 to 1292°F			
Measurement Accuracy	+/-0.5% of full scale of PT100, +/-1% of full scale for TC & mV signals			
Resolution	0.1°C for RTD, J,E & 1° for S,B,K & 0.001°C for mV signals			
Configurable Set Points	4			
Display	Dual row 7 segment display with LED indications, 4-digit process value, 4 digit set value			
Keypad	4-Keys: - Exit / Configurable Key, - Down, - Up, - Enter / Select			
Output 1	Relay: SPST 8A @ 240 VAC / 28 VDC	Analog: 0 - 10V / 4 - 20 mA Configurable Retransmission Output		Relay: SPST 8A @ 240 VAC / 28 VDC
Output 2	Relay: SPST 5A @ 240 VAC / 28 VDC			
Output 3	SSR: 12 VDC, 24 mA Short Circuit Protection		Relay: SPST 5A @ 240 VAC / 28 VDC	
Analog Output Update Rate	N A		150ms to 5s	
Alarm Types	Absolute (High/Low/Band), Deviation (High/Low/Band), Sensor Break, Loop Break,			
Soft Start Feature	Yes			
Ramp Soak Feature	6 Segment Ramp Soak Profile			
RS 485 Communication	RS 485 Communication			
Transmission Speed & Type	300 to 19200 BPS (Half Duplex)			
Transmission Protocol	Modbus RTU			
Operating Temperature	0°C to +50°C			
Storage Temperature	-20°C to +60°C			
Humidity (Non Condensing)	80% (Rh)			
Enclosure	Flame Retardant UL94V0			
Dimensions (W x H x D) (in mm)	48 x 48 x 91.5			
Weight (unpacked)	130 g			
Mounting	Flush			
Certification				
Degree of Protection	IP 20 Terminal & Enclosure, IP 40 (For Front Panel only)			
EMI / EMC				
Harmonic Current Emissions	IEC 61000-3-2	Ed. 3.2 (2009-04) Class A		
ESD	IEC 61000-4-2	Ed. 2.0 (2008-12) Level II		
Radiated Susceptibility	IEC 61000-4-3	Ed. 3.2 (2010-04) Level III		
Electrical Fast Transients	IEC 61000-4-4	Ed. 3.0 (2012-04) Level IV		
Surges	IEC 61000-4-5	Ed. 2.0 (2005-11) Level IV		
Conducted Susceptibility	IEC 61000-4-6	Ed. 3.0 (2008-10) Level III		
Voltage Dips & Interruptions (AC)	IEC 61000-4-11	Ed. 2.0 (2004-03) All 7 Levels		
Conducted Emission	CISPR 14-1	Ed. 5.2 (20011-11) Class A		
Radiated Emission	CISPR 14-1	Ed. 5.2 (20011-11) Class B		
Environmental				
Cold Heat	IEC 60068-2-1	Ed. 6.0 (2007-03)		
Dry Heat	IEC 60068-2-2	Ed. 5.0 (2007-07)		
Vibration	IEC 60068-2-6	Ed. 7.0 (2007-12) 5g		
Repetitive Shock	IEC 60068-2-27	Ed. 4.0 (2008-02) 40g, 6ms		
Non-Repetitive Shock	IEC 60068-2-27	Ed. 4.0 (2008-02) 30g, 15ms		

ORDERING INFORMATION

Dual Acting PID Controller

Cat. No.	Description
151A13B1*	2 Relays (SPST 8A & 5A, 240 VAC / 28 VDC), SSR driving output (12 VDC, 24mA)
151B13B1*	1 Relay (SPST 5A, 240 VAC / 28 VDC), Analog output (0-10V, 4-20mA), SSR driving output (12 VDC, 24mA)
151C13B1*	2 Relays (SPST 5A each, 240V AC/28V DC), Analog output (0-10V, 4-20mA)
151D13B1*	3 Relays (SPST One 8A & Two 5A, 240V AC / 28V DC)

*Note: With RS485 Modbus Communication

PID Temperature Controller Series PR 69



Cat. No.	151A12B	151B12B	151C12B	151D12B
Parameters				
Supply Voltage (φ)	110 - 240 VAC			
Supply Variation	-20% to +10% (of φ)			
Frequency	50/60 Hz			
Control Action	ON/OFF (Symmetric / Asymmetric), PID (Single Acting)			
Tuning Method	Auto Tuning / Manual Tuning			
Temperature sensors / Inputs	Thermocouple: J, K, E, S, B, R; RTD: PT100 - 3 wire compensation; Analog Signal: (0-50 mV, 0-60 mV, 12-60 mV)			
Measurement Range	Sensor J: 0 to 700°C/32 to 1292°F, Sensor K: 0 to 1300°C/32 to 2372°F, Sensor E: 0 to 600°C/32 to 1112°F, Sensor R: 0 to 1750°C/32 to 3182°F, Sensor S: 0 to 1750°C/32 to 3182°F, Sensor B: 250 to 1820°C/482 to 3308°F, Sensor PT100 3 wire: - 200 to 700°C/-328 to 1292°F			
Measurement Accuracy	± 0.5% of full scale of PT100, ± 1% of full scale for TC & mV signals			
Resolution	0.1°C for RTD, J,E & 1° for S,B,K & 0.001°C for mV signals			
Configurable Set Points	2			
Display	Dual row 7 segment display with LED indications, 4-digit process value, 4 digit set value			
Keypad	4-Keys: - Exit / Configurable Key, - Down, - Up, - Enter / Select			
Output 1	Relay: SPST 8A @ 240 VAC / 28 VDC	Analog: 0 - 10V / 4 - 20 mA Configurable Retransmission Output		Relay: SPST 8A @ 240 VAC / 28 VDC
Output 2	Relay: SPST 5A @ 240 VAC / 28 VDC			
Output 3	SSR: 12 VDC, 24 mA Short Circuit Protection		Relay: SPST 5A @ 240 VAC / 28 VDC	
Analog Output Update Rate	N A	150ms to 5s		N A
Alarm Types	Absolute (High/Low/Band), Deviation (High/Low/Band), Sensor Break, Loop Break,			
Soft Start Feature	Yes			
Ramp Soak Feature	No			
Operating Temperature	0°C to +50°C			
Storage Temperature	-20°C to +60°C			
Humidity (Non Condensing)	80% (Rh)			
Enclosure	Flame Retardant UL94V0			
Dimensions (W x H x D) (in mm)	48 x 48 x 91.5			
Weight (unpacked)	130 g			
Mounting	Flush			
Certification				
Degree of Protection	IP 20 Terminal & Enclosure, IP 40 (For Front Panel only)			
EMI / EMC				
Harmonic Current Emissions	IEC 61000-3-2	Ed. 3.2 (2009-04) Class A		
ESD	IEC 61000-4-2	Ed. 2.0 (2008-12) Level II		
Radiated Susceptibility	IEC 61000-4-3	Ed. 3.2 (2010-04) Level III		
Electrical Fast Transients	IEC 61000-4-4	Ed. 3.0 (2012-04) Level IV		
Surges	IEC 61000-4-5	Ed. 2.0 (2005-11) Level IV		
Conducted Susceptibility	IEC 61000-4-6	Ed. 3.0 (2008-10) Level III		
Voltage Dips & Interruptions (AC)	IEC 61000-4-11	Ed. 2.0 (2004-03) All 7 Levels		
Conducted Emission	CISPR 14-1	Ed. 5.2 (20011-11) Class A		
Radiated Emission	CISPR 14-1	Ed. 5.2 (20011-11) Class B		
Environmental				
Cold Heat	IEC 60068-2-1	Ed. 6.0 (2007-03)		
Dry Heat	IEC 60068-2-2	Ed. 5.0 (2007-07)		
Vibration	IEC 60068-2-6	Ed. 7.0 (2007-12) 5g		
Repetitive Shock	IEC 60068-2-27	Ed. 4.0 (2008-02) 40g, 6ms		
Non-Repetitive Shock	IEC 60068-2-27	Ed. 4.0 (2008-02) 30g, 15ms		

ORDERING INFORMATION

Single Acting PID Controller

Cat. No.	Description
151A12B	2 Relays (SPST 8A & 5A, 240 VAC / 28 VDC), SSR driving output (12 VDC, 24mA)
151B12B	1 Relay (SPST 5A, 240 VAC / 28 VDC), Analog output (0-10V, 4-20mA), SSR driving output (12 VDC, 24mA)
151C12B	2 Relays (SPST 5A each, 240V AC/28V DC), Analog output (0-10V, 4-20mA)
151D12B	3 Relays (SPST One 8A & Two 5A, 240V AC / 28V DC)



CONNECTION DIAGRAM

151A12B

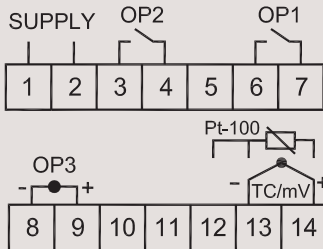

151B12B

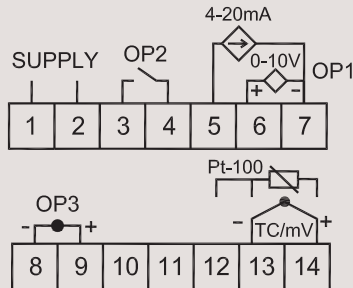

151C12B

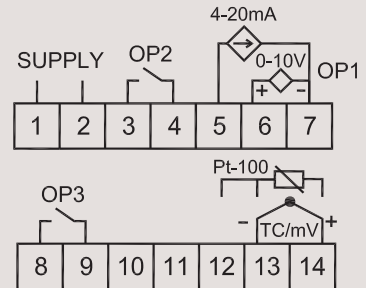

151D12B

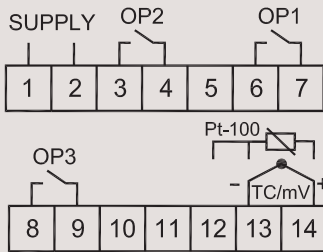

151A13B1

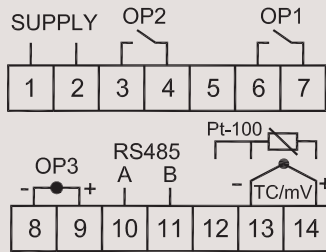

151C13B1

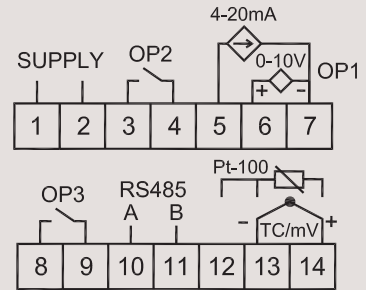

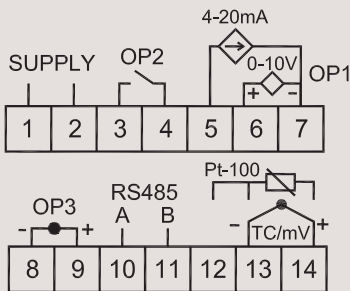

151B13B1

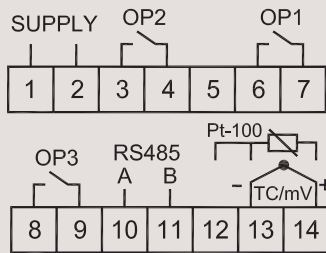

151D13B1



TERMINAL TORQUE & CAPACITY

	Torque - 0.54 N.m (4.5 Lb.in) Terminal screw - M3
	Solid Wire - 1 X 0.12...2 mm ²
AWG	1 X 26 to 14

MOUNTING DIMENSION (mm)

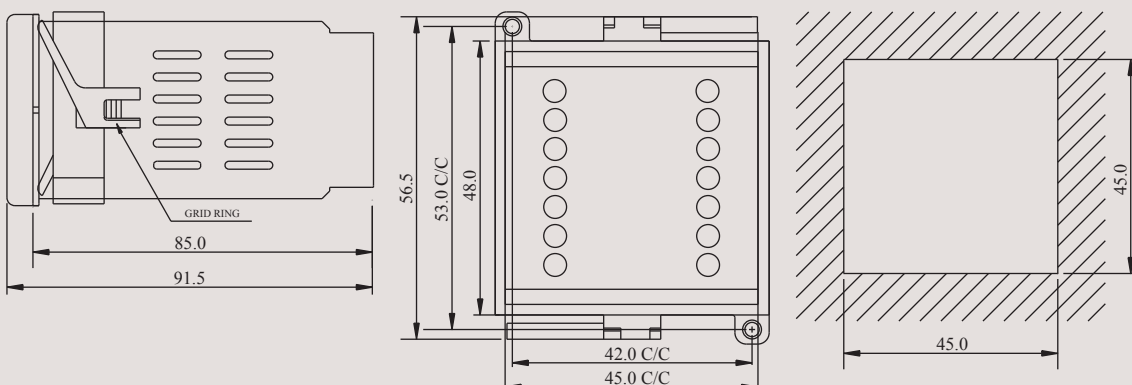

ON-OFF Temperature Controller Series PR 433 & PR 434

- Highly Accurate Performance.
- Luxurious Single 3-digit LED Display.
- Wide supply range: 110-240VAC (Un), -20 to +10% of Un.
- Front keypad with 4 keys.
- Thermocouple (J & K)/RTD 3-wire (Pt-100) sensor inputs.
- Control Modes: Proportional, ON-OFF Asymmetric, ON-OFF Symmetric.
- °C & °F temperature unit selectable
- Control Output: Relay & SSR Drive (Individual products)



Cat. No.	151G11B	151H11B	
Parameters			
Supply Voltage (φ)	110 - 240 VAC		
Supply Variation	-20% to +10% (of φ)		
Frequency	50/60 Hz		
Control Action	ON/OFF (Symmetric / Asymmetric) & Proportional		
Power Consumption	6 VA @ 265 VAC		
Temperature sensors / Inputs	Thermocouple: J, K ; RTD: PT100 - 3 wire compensation;		
Measurement Range	Sensor J: -5°C to 750°C / 23°F to 999°F, Sensor K: -20°C to 850°C / -4°F to 999°F, Sensor PT100 3 wire: - 100°C to 650°C / -148°F to 999°F		
Measurement Accuracy	± 0.5% of full scale		
Resolution	1°C Fixed		
Configurable Set Points	1		
Display	7 segment, 3 digit LED display		
Keypad	4-Keys: - ESC, - Down, - Up, - Enter / Select		
Output 1	Relay: (1 NO) SPST 5A @ 240 VAC / 30 VDC	SSR: 12 VDC, 30 mA	
LED Indications:			
	OP1 (Red LED)	Continuous ON	Relay output ON
	°F (Red LED)	Continuous ON	Display °F value
	°C (Red LED)	Continuous OFF	Display °C value
Error Indications			
	SBR	SENSOR OPEN/BREAK ERROR	
	OVR	OVER RANGE ERROR	
	UNR	UNDER RANGE ERROR	
Operating Temperature	0°C to +50°C		
Storage Temperature	-10°C to +60°C		
Humidity (Non Condensing)	80% (Rh)		
Enclosure	Flame Retardant UL 94 - V0		
Dimensions (W x H x D) (in mm)	48 x 48 x 91.5		
Weight (unpacked)	120 g		
Mounting	Flush		
Certification			
Degree of Protection	IP 20 Terminal & Enclosure, IP 40 (For Front Panel only)		
EMI / EMC			
Harmonic Current Emissions	IEC 61000-3-2	Ed. 3.2 (2009-04) Class A	
ESD	IEC 61000-4-2	Ed. 2.0 (2008-12) Level II	
Radiated Susceptibility	IEC 61000-4-3	Ed. 3.2 (2010-04) Level III	
Electrical Fast Transients	IEC 61000-4-4	Ed. 3.0 (2012-04) Level IV	
Surges	IEC 61000-4-5	Ed. 2.0 (2005-11) Level IV	
Conducted Susceptibility	IEC 61000-4-6	Ed. 3.0 (2008-10) Level III	
Voltage Dips & Interruptions (AC)	IEC 61000-4-11	Ed. 2.0 (2004-03) All 7 Levels	
Conducted Emission	CISPR 14-1	Ed. 5.2 (20011-11) Class A	
Radiated Emission	CISPR 14-1	Ed. 5.2 (20011-11) Class B	
Environmental			
Cold Heat	IEC 60068-2-1	Ed. 6.0 (2007-03)	
Dry Heat	IEC 60068-2-2	Ed. 5.0 (2007-07)	
Vibration	IEC 60068-2-6	Ed. 7.0 (2007-12) 5g	
Repetitive Shock	IEC 60068-2-27	Ed. 4.0 (2008-02) 40g, 6ms	
Non-Repetitive Shock	IEC 60068-2-27	Ed. 4.0 (2008-02) 30g, 15ms	

ORDERING INFORMATION

Single Acting PID Controller

Cat. No.	Description
151G11B	Series PR-433, Relay Output (SPST 5A, 240 VAC / 30 VDC)
151H11B	Series PR-434, SSR driving output (12 VDC, 30 mA)

ON-OFF Temperature Controller Series PR 433 & PR 434



CONNECTION DIAGRAM

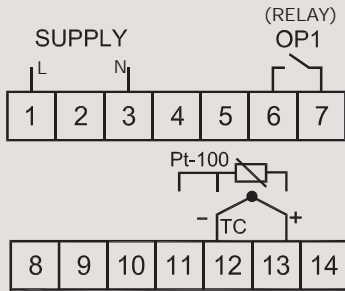

151G11B

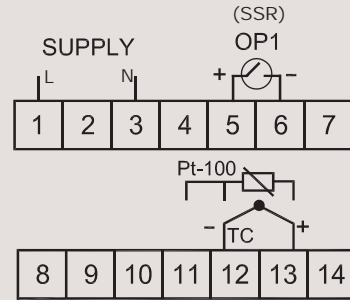

151H11B

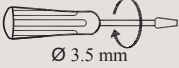

TERMINAL TORQUE & CAPACITY

 Ø 3.5 mm	Torque - 0.54 N.m (4.5 Lb.in) Terminal screw - M3
	Solid Wire - 1 X 0.12...2 mm ²
AWG	1 X 26 to 14

MOUNTING DIMENSION (mm)

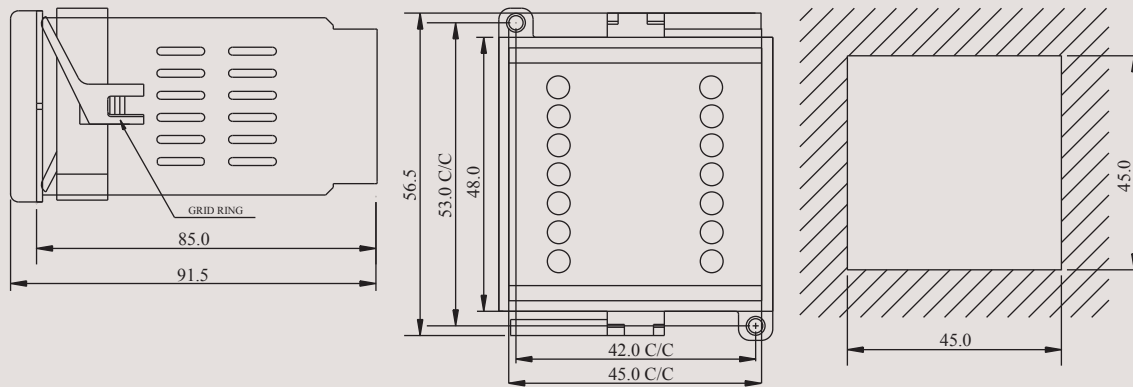



Note:

- Innovation being a continuous process, design and specifications are subject to change without prior notice.
- User is recommended to ensure the suitability of the products for intended application.
- GIC is not responsible for consequential damage out of use of its products.



General Industrial Controls Private Limited

T-107, M.I.D.C., Bhosari, Pune 411026 (INDIA)

Tel: +91 20 30680003 / 11 / 31 / 39 Fax: +91 20 27122574

Email: marketing@gicindia.com; sales@gicindia.com | www.gicindia.com