

# Mobile Applications



# About ebm-papst Inc.



## *headquarters - farmington, CT*

- » 250K sq ft
- » 20 Regional Offices
- » 300 Employees
- » Complete Air Testing Lab On Site
- » ISO 9001 and 14001 Certification
- » Logistic centers in Farmington (CT), Toronto, and Dublin
- » National Distributor Locations

With offices in major cities throughout North America and Ireland, our highly-skilled and experienced team of professionals is ready to tackle your most difficult air moving challenges and offer solutions that meet your needs. We serve all markets including IT & Telecomm, HVAC, Refrigeration, Gas & Heating, Household Appliances, Industrial, Drive Systems, Transportation, Agriculture, Medical, and more. You can always count on prompt, courteous service. Customer satisfaction is our number one priority.

## *expert support when and where you need it*

Knowledgeable field sales professionals are close by for face-to-face meetings. Dedicated inside sales associates fulfill all your ordering requirements. To assist you with order management, our customer service department provides automated services such as shipment notifications, reorder notifications, and invoicing.

To find the right air moving solution for your needs, our experienced application engineers are at your service to answer all your product application questions. Our on-site testing lab is available to our customers for product / prototype testing. We offer air flow, noise, environmental (including Salt Fog chambers), and temperature testing. Burn-in ovens are also available.

Our electrical engineering team, with diverse industry and product design backgrounds, provides a full range of services including hardware and software design, analysis and testing, and electronics manufacturing. Some of the services performed in our on-site lab are circuit analysis, reliability and environmental testing, prototype build and testing, test equipment design and build.

## *value-added services to meet all your needs*

ebm-papst, the world's leading source for engineered air movement solutions, provides a "total solution" approach to your cooling requirements using our extensive in-house resources. Custom assemblies are designed by our engineers to your specifications for a wide range of applications. Sheet metal fabrication and finishing / painting is performed on our extensive line of state-of-the-art equipment, ensuring superior quality and maximum flexibility in the manufacturing process. Custom assembly incorporating ebm-papst air movers, custom PCBs, power supplies, electronic filters, air filters, wire harnesses, labeling, fasteners / connectors / accessories, and more is performed on site.

## *logistics and inventory management programs*

We have over 90,000 sq ft of climate-controlled warehousing at our facilities offering real-time inventory transactions and bar-coded inventory. Inventory management programs such as Kanban, demand/pull, safety stock, consignment, and local warehousing can be customized to your requirements.



# Table of Contents



*At a Glance*..... 4



*Overview of Mobile Market* ..... 5-7



*Blowers for Mobile Applications* ..... 8-15



*Axials for Mobile Applications*..... 16-21



*EC Centrifugal Fans for Mobile Applications*..... 22-23



*Accessories*..... 24



*Electrical Connections*..... 25-27

# At a Glance

Our brushless DC axial fans and brushless DC dual centrifugal blowers set the trend in mobile climate control. They not only fulfill today's increased expectations for comfort but also work without wear and tear because they are brushless. No extra maintenance, no additional service required. That is the reliability you expect and trust from ebm-papst.

## Advantages of our brushless fans and blowers

- ▶ Over 40,000 design life hours
- ▶ Infinitely variable or stepped speed control
- ▶ High efficiency
- ▶ Low noise design with dual dynamic plane
- ▶ Increased reliability due to optimized balance and elimination of motor brushes
- ▶ Can be retrofitted to existing systems
- ▶ Meets EMC requirements
- ▶ Control characteristics can be optimized per application
- ▶ Low power consumption speed control



# Overview of Mobile Market

## *mobile applications*

Proper air-conditioning, ventilation and heating for the mobile industry is of vital importance for the needs of both driver and passenger comfort. Whether for drivers in sleeper trunks, tractors, and refrigerated transport systems or passengers in buses and coaches, the demand for comfort must be met. Manufacturers and engineers with mobile applications can rely on the expertise of ebm-papst brushless and trouble-free centrifugal blowers and axial fans to meet these challenging demands.

In today's mobile applications, motors with integrated EC technology have become the ideal standard. Why? Because EC technology offers a substantially longer service life, open control option, and diagnostics for output - not to mention excellent EMC properties and extremely low noise! Best of all, since the motors are electronically controlled and electronics are directly integrated into the motor itself there are no brushes to wear prematurely!

## *meeting tough specifications with new technologies*

In mobile applications it is important for the fans and blowers to withstand constantly fluctuating factors of the environment. It is for this reason that ebm-papst mobile products are reliably protected against load dump, polarity protection, vibration, and damage caused by humidity and contamination across a wide temperature range. Our products have withstood the scrutiny of our extreme environmental tests, designed together with market-leading OEM's, and based on real-world conditions (such as salt spray fog, vibration, and temperature fluctuations) to ensure superior performance of our fans.

Our brushless designs offer a much longer service life than brush designs. In brush motors, erosion is a normal byproduct of motor operation, and the eroded brush material is extremely abrasive. This resulting material can make its way into the bearings and further damage commutation surfaces. The typical life for standard brush motors is approximately 5,000 hours, long life brush motors might reach 8,000 - 10,000 hours. Our brushless motors are design to meet or exceed 40,000 hours. Furthermore, as brush designs approach the end of their life cycles, EMI characteristics degrade. Excessive EMI emissions can cause equipment communication problems and service calls for a fleet operator. Our brushless motors do not exhibit this change in EMI characteristics.



***Our products are subjected to rigorous testing***

# Overview of Mobile Market

## *advantages of motor control with brushless vs. brush*

Brushless motors with speed controllability offer more freedom to system designers than ever before. Brushless motors can receive low power speed control input signals that control motor speed and performance by changing the motor speed electronically. This approach allows for optimization of the air conditioning or ventilation system by allowing the designer to do the following:

- ▶ Vary the air mover speed with a simple 10 KOhm trim pot.
- ▶ Vary the air mover speed with a PWM signal or linear DC control voltage from a system controller.
- ▶ Vary the air mover speed based on a remote temperature sensor feedback to directly respond to changing air conditioner load automatically.
- ▶ Establish simple 3 speed or custom fixed speed designs for a specific customer application as required by the system designer.

Many of these products can be used in specialized control applications such as:

- ▶ Operation at 1/2 speed during a special situation like low temperature or during a low demand period.
- ▶ Varying the fan speed with a referenced control voltage having a reversed slope.

### Wire Wound Resistors with Brush Motors



- ▶ Waste heat dissipated in your AC ducting
- ▶ Requires large gauge wiring for high amps.

### Multi-position Switch Used with Electronic Brushless Motors



- ▶ Offer many fixed motor speeds
- ▶ Product speeds easily established for specific applications

*Technical connection information is available in the Wiring Diagram section.*

# Overview of Mobile Market

## *efficient and effective speed control*

The commutator in brush motors distribute power to motor coils. This commutator is made up of copper segments embedded in an insulating mass. Mechanical springs press the integrated carbon brushes against the commutator. Thus, exposed to friction, these two mechanical components are the weak spot of conventional DC motors. After 5,000 operating hours, typically the carbon brushes are used up. The brushes need to be replaced often with the entire blower. Speed control can only be realized via external electronics. With ebm-papst brushless DC motors, brushes and the commutator are eliminated. The brushless design not only saves replacement and repair costs, but unproductive down time.

*Breaking the 40,000 hour product life barrier* - Most customers express a need for designs with service life values of 40,000 hours or more. These needs are further mandated by the Transit Authorities for longer service intervals so to allow transit equipment to be “on the job” generating income vs. “on the lift” for service. Brushless fans and blowers achieve this goal by eliminating one of the fastest wearing parts...the brush! Bearing life is also extended by eliminating worn brush material from contaminating the bearing.

*Reducing costs of Speed Controllable and Multi-Speed AC systems* - Multi-Speed “Brush” motor systems have used wire resistors to reduce motor speed as common practice. This approach generated a lot of waste heat and was labor intensive to install heavy gauge wiring between the HVAC control and the air conditioners’ resistor components (see diagram below). Brushless motor systems require heavy gauge wire between the power source and the drive motor main inputs.

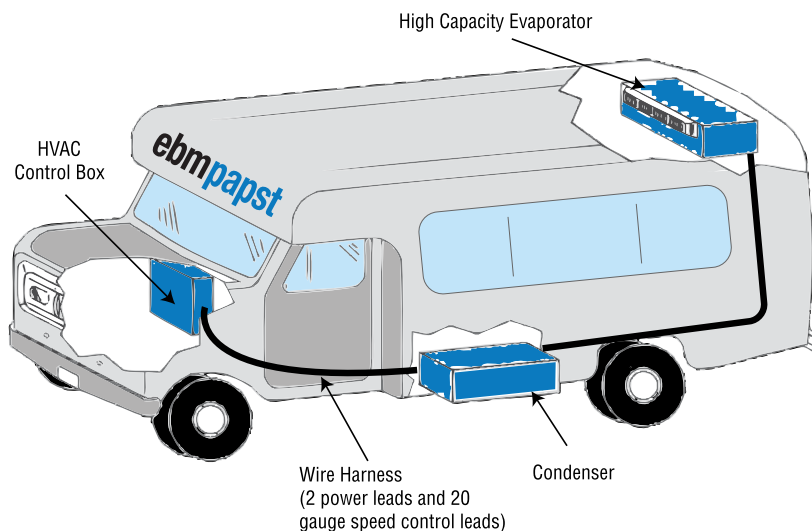

Savings of implementing brushless motor systems into your applications are:

- ▶ Lighter gauge wire for speed control wiring typically reducing from 10 AWG to 22 AWG.
- ▶ Greatly reduced installation costs, especially when retrofitting.
- ▶ High current capacity wire resistors are eliminated. No waste heat issues or speed control resistor ventilation required.

# Blowers for Mobile Applications

*top performance, minimal mounting space*

ebm-papst brushless DC twin centrifugal blowers are the smartest choice for air movement in industrial vehicles. The advanced technology integrates all electronics within the motor housing, enhancing performance and minimizing size. Furthermore, the life of the blower maintenance reduces by 4-5 times of a standard brush motor design is possible.

## Main Applications:

- ▶ Evaporator blowers for air-conditioning systems in busses and coaches
- ▶ Driver front box ventilation
- ▶ Cabin ventilation for mobile applications

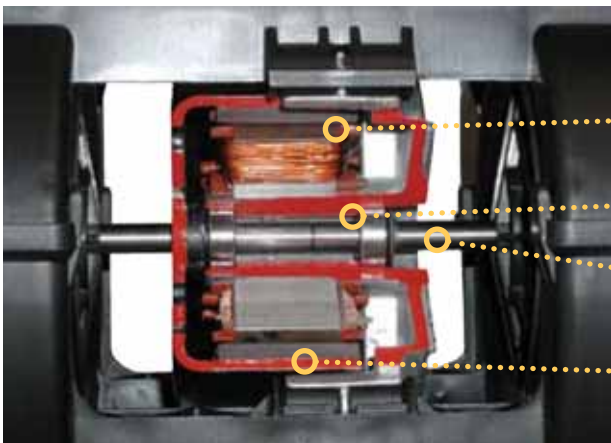
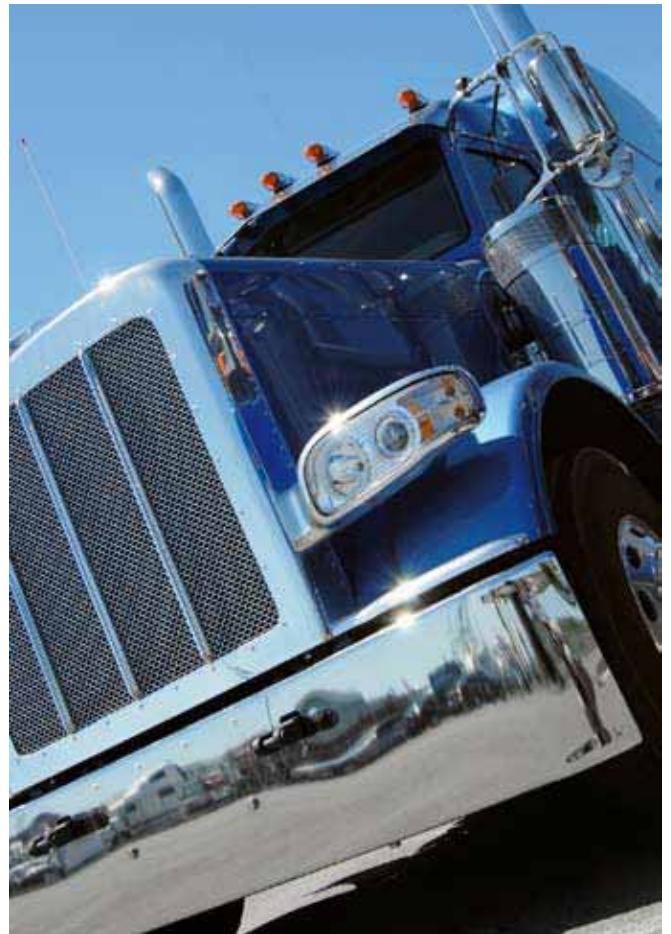

## K3G097-A Features:

- Coated motor winding to fight corrosion
- Ball bearing design for rugged mobile applications
- Oversized steel shafts for mobile applications
- Dual plane, dynamically balanced brushless DC motor for smooth operation and long life

# K3G097-AK



## Ø 097mm EC Twin Centrifugal Blowers

- **Material:** Scroll housing made of plastic PP - color black (corresponding to UL 94 HB); impeller made of plastic PA
- **Insulation Class:** "B" according to EN 60335-1
- **Bearings:** Maintenance-free ball bearings on both sides
- **Motor protection:** Over-temperature protection, reverse battery and locked-rotor protection, load dump, under-voltage detection
- **EMC:** VDE 0879-2, interference suppression grade 5

Part Number	Curve	CFM @ 0	Voltage	Voltage Range	Power (W)	dBA	Max Amb. Temp C	Speed (RPM)	Weight (lbs.)	Electrical connection
K3G097-AK32-42	1	620	13 <sup>(1)</sup>	9-15	280	65	85 <sup>(3)</sup>	3250	5.07	A
K3G097-AK36-55	2	694	13 <sup>(1)</sup>	9-15	385	69	85 <sup>(3)</sup>	3740	5.73	A
K3G097-AK34-43	3	724	26 <sup>(2)</sup>	16-32	370	69	85 <sup>(3)</sup>	3730	5.07	B

(1) 12 Volt variant    (2) 24 Volt variant    (3) free blowing, not recommended for non-stop operation at 85°C

	n [min <sup>-1</sup> ]	P <sub>1</sub> [W]	η <sub>ges</sub> [%]	L <sub>pA</sub> [dBA]	n [min <sup>-1</sup> ]	P <sub>1</sub> [W]	η <sub>ges</sub> [%]	L <sub>pA</sub> [dBA]
① ①	3250	280	33	65	② ①	3740	385	34
① ②	3525	259	39	65	② ②	4015	356	41
① ③	3850	226	45	65	② ③	4475	341	46
① ④	4125	189	44	66	② ④	4835	292	47

	n [min <sup>-1</sup> ]	P <sub>1</sub> [W]	η <sub>ges</sub> [%]	L <sub>pA</sub> [dBA]
③ ①	3730	370	40	69
③ ②	3970	333	47	68
③ ③	4415	314	51	68
③ ④	4800	275	49	69

**Curve**

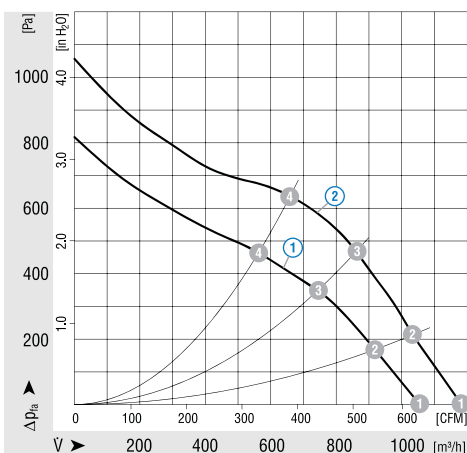

**Curve**

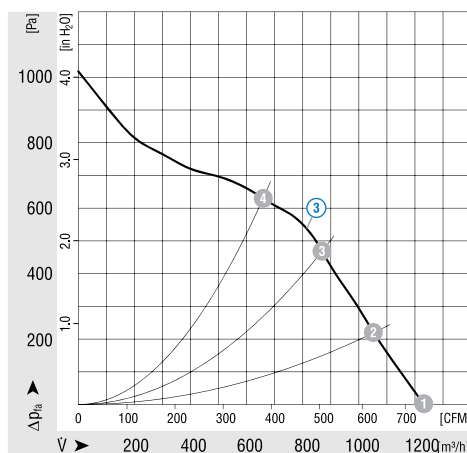

# K3G097-BK



## Ø 097mm EC Twin Centrifugal Blowers

- **Material:** Scroll housing made of plastic PP - color black (corresponding to UL 94 HB); impeller made of plastic PA
- **Insulation Class:** "B" according to EN 60335-1
- **Bearings:** Maintenance-free ball bearings on both sides
- **Motor protection:** Over-temperature protection, reverse battery and locked-rotor protection, load dump, under-voltage detection
- **EMC:** VDE 0879-2, interference suppression grade 5

Part Number	Curve	CFM @ 0	Voltage	Voltage Range	Power (W)	dBA	Max Amb. Temp C	Speed (RPM)	Weight (lbs.)	Electrical connection
K3G097-BK32-42	1	553	13 <sup>(1)</sup>	9-15	260	67	85 <sup>(3)</sup>	3400	5.07	A
K3G097-BK36-56	2	618	13 <sup>(1)</sup>	9-15	358	69	85 <sup>(3)</sup>	3950	5.73	A
K3G097-BK34-43	3	640	26 <sup>(2)</sup>	16-32	345	69	85 <sup>(3)</sup>	3940	5.07	B

(1) 12 Volt variant    (2) 24 Volt variant    (3) free blowing, not recommended for non-stop operation at 85°C

	n [min <sup>-1</sup> ]	P <sub>1</sub> [W]	η <sub>ges</sub> [%]	L <sub>pA</sub> [dBA]	n [min <sup>-1</sup> ]	P <sub>1</sub> [W]	η <sub>ges</sub> [%]	L <sub>pA</sub> [dBA]	
① ①	3400	260	26	67	② ①	3950	358	26	69
① ②	3550	241	34	66	② ②	4175	353	33	69
① ③	3775	219	43	65	② ③	4440	341	44	68
① ④	4040	185	40	64	② ④	4805	299	44	68

	n [min <sup>-1</sup> ]	P <sub>1</sub> [W]	η <sub>ges</sub> [%]	L <sub>pA</sub> [dBA]
③ ①	3940	345	30	69
③ ②	4100	329	39	68
③ ③	4460	322	49	67
③ ④	4800	277	48	68

Curve

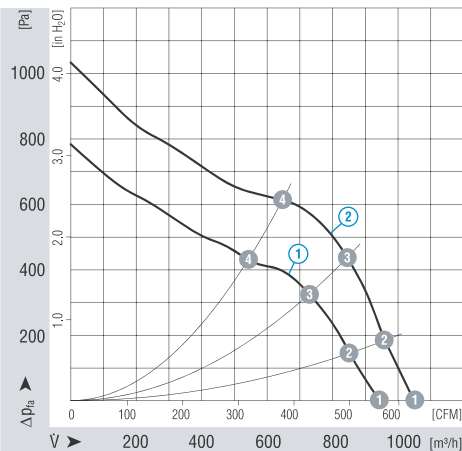

Curve

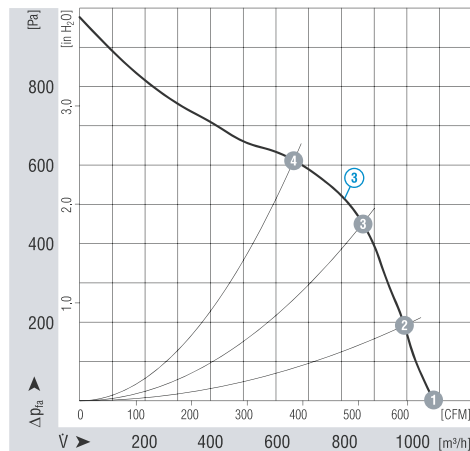

# K3G097-AK/BK Drawings

## K3G097-AK Drawing

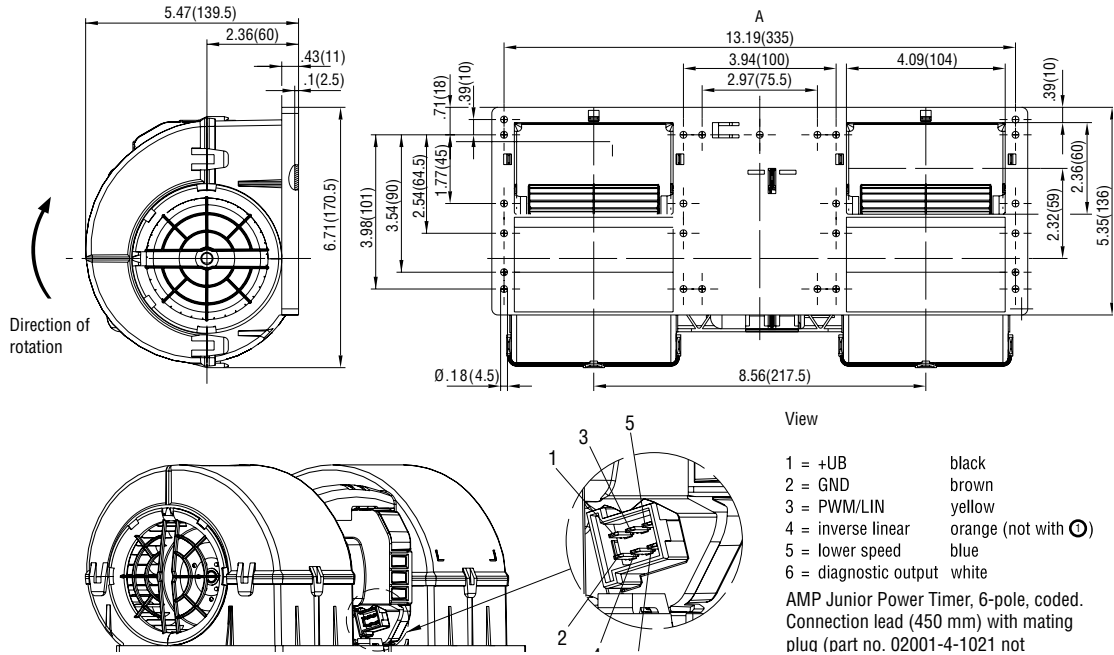

## K3G097-BK Drawing

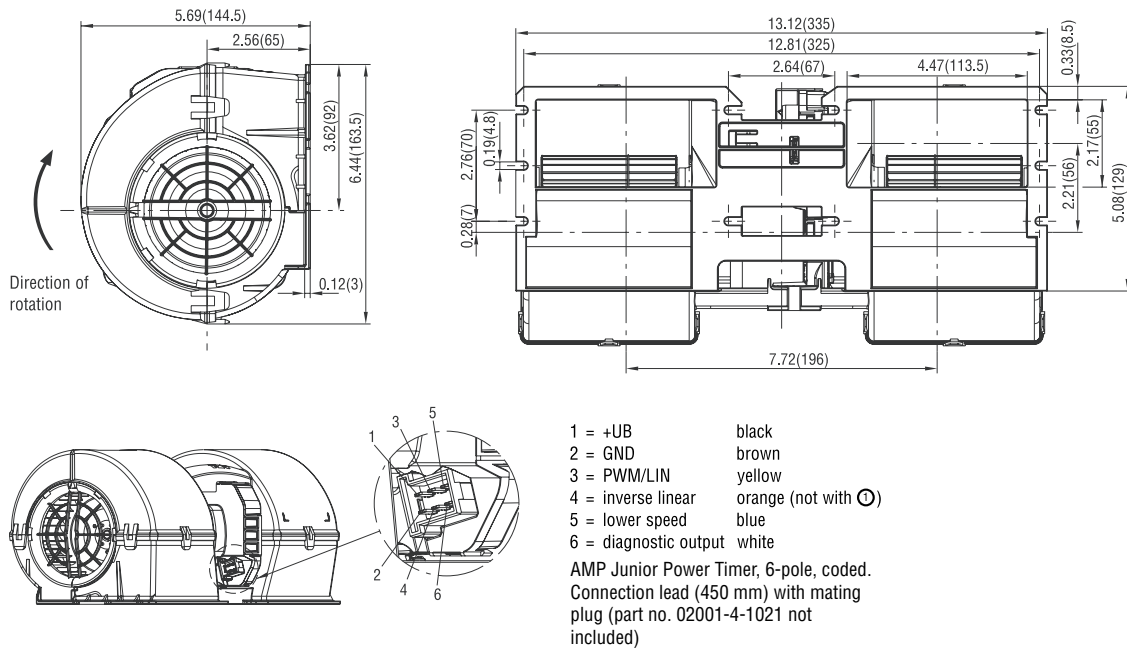

# K3G097 BASIC

## *basic line - cost-efficient and high quality*

Designed to complement our existing product line successfully used in the market for years, ebm-papst has managed to present yet another highly powerful product - the K3G097 Basic line of twin centrifugal blowers. These blowers are the result of market optimizing measures based on years of partnership with our customers.

With the K3G097 Basic line, customers can be assured that the highest of quality standards are met. State-of-the-art integrated electronics are incorporated and typically provides customers with more than 40,000 operating hours of reliable service. The Basic line offers a simple three-step open loop speed control of various air-performance levels with separate inputs. The blowers are easy to operate and contain all essential functions required for basic applications. The K3G097 Basic line allows all customers the flexibility to use the brushless technology of ebm-papst products in the competitive global market.

### Applications

- ▶ Air-conditioning systems in busses
- ▶ Driver front box ventilation
- ▶ Cabin air-conditioning for tractors and trucks

### Benefits

- ▶ More than 40,000 operating hours
- ▶ Variable speed control / 3 fixed level control
- ▶ High efficiency and low noise emission
- ▶ Integrated electronics
- ▶ e1-approval
- ▶ Tested according to automotive specifications



# K3G097-AK BASIC



## Ø 097mm EC Twin Centrifugal Blowers

- **Material:** Scroll housing made of plastic PP - color black (corresponding to UL 94 HB); impeller made of plastic PA
- **Insulation Class:** "B" according to EN 60335-1
- **Bearings:** Maintenance-free ball bearings on both sides
- **Motor protection:** Over-temperature protection, reverse battery and locked-rotor protection, load dump, under-voltage detection
- **EMC:** e1 approval according to 2006/28/EG
- **Type of protection:** IP 24 KM (without plug)
- **Connector plug:** 6-pole, coded; connection lead (450 mm) with mating plug part no. 02001-4-1021 (not included)

Part Number	Curve	CFM @ 0	Voltage	Voltage Range	Power (W)	dBA	Max. Amb. Temp C	Speed (RPM)	Weight (lbs.)	Electrical Connection
K3G097-AK32-70*	1	629	13	9-15	276	68	85 <sup>(3)</sup>	3250	2.00	F
K3G097-AK34-65	2	759	26	16-32	394	72	85 <sup>(3)</sup>	3830	4.40	F

\* Preliminary, data subject to chance

<sup>(1)</sup> 12-volt variant

<sup>(2)</sup> 24-volt variant

<sup>(3)</sup> free blowing, not recommended for non-stop operation at 85°C

	n [min <sup>-1</sup> ]	P <sub>1</sub> [W]	η <sub>ges</sub> [%]	Lp <sub>A</sub> [dBA]	n [min <sup>-1</sup> ]	P <sub>1</sub> [W]	η <sub>ges</sub> [%]	Lp <sub>A</sub> [dBA]
① ①	3237	278	35	68	① ⑦	3039	104	46
① ②	3491	250	41	66	① ⑧	3157	85	38
① ③	3764	216	46	65	① ⑨	2045	66	33
① ④	4247	206	40	66	① ⑩	2133	60	36
① ⑤	2662	145	36	64	① ⑪	2236	51	39
① ⑥	2849	122	44	61	① ⑫	2338	41	33

	n [min <sup>-1</sup> ]	P <sub>1</sub> [W]	η <sub>ges</sub> [%]	Lp <sub>A</sub> [dBA]	n [min <sup>-1</sup> ]	P <sub>1</sub> [W]	η <sub>ges</sub> [%]	Lp <sub>A</sub> [dBA]
② ①	3830	394	43	72	② ⑦	3510	149	52
② ②	4100	347	49	69	② ⑧	3660	120	46
② ③	4380	285	54	68	② ⑨	2240	79	40
② ④	4630	238	48	68	② ⑩	2340	67	45
② ⑤	3150	215	42	68	② ⑪	2430	53	47
② ⑥	3330	185	49	65	② ⑫	2480	43	38

### Curve

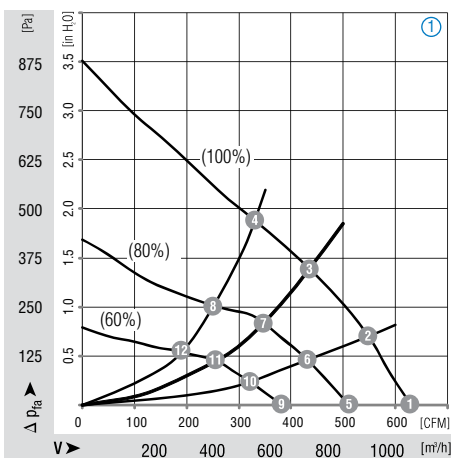

### Curve

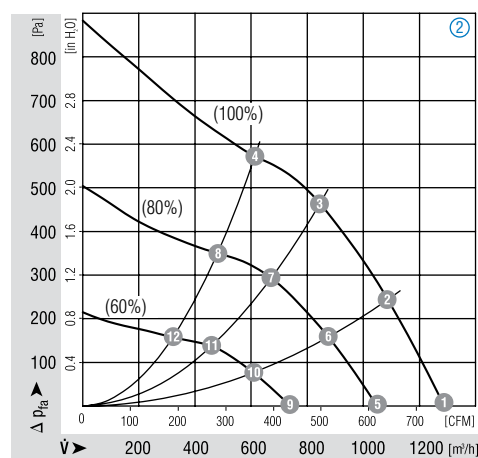

# K3G097-BK BASIC



## Ø 097mm EC Twin Centrifugal Blowers

- **Material:** Scroll housing made of plastic PP - color black (corresponding to UL 94 HB); impeller made of plastic PA
- **Insulation Class:** "B" according to EN 60335-1
- **Bearings:** Maintenance-free ball bearings on both sides
- **Motor protection:** Over-temperature protection, reverse battery and locked-rotor protection, load dump, under-voltage detection
- **EMC:** e1 approval according to 2006/28/EG
- **Type of protection:** IP 24 KM (without plug)
- **Connector plug:** 6-pole, coded; connection lead (450 mm) with mating plug part no. 02001-4-1021 (not included)

Part Number	Curve	CFM @ 0	Voltage	Voltage Range	Power (W)	dBA	Max Amb. Temp C	Speed (RPM)	Weight (lbs.)	Electrical Connection
K3G097-BK34-65	1	653	26 <sup>(1)</sup>	16-32	344	70	85 <sup>(2)</sup>	4040	4.40	F

(<sup>1</sup>) 12-Volt variant      (<sup>2</sup>) free blowing, not recommended for non-stop operation at 85°C

	n [min <sup>-1</sup> ]	P <sub>1</sub> [W]	η <sub>ges</sub> [%]	L <sub>p</sub> [dBA]	n [min <sup>-1</sup> ]	P <sub>1</sub> [W]	η <sub>ges</sub> [%]	L <sub>pA</sub> [dBA]	
① ①	4040	344	31	70	① ⑦	3520	145	49	63
① ②	4210	325	39	69	① ⑧	3650	121	42	62
① ③	4380	279	51	68	① ⑨	2330	67	30	57
① ④	4630	242	44	68	① ⑩	2360	62	36	55
① ⑤	3310	186	31	66	① ⑪	2410	53	43	54
① ⑥	3390	171	40	64	① ⑫	2480	42	37	53

## Curve

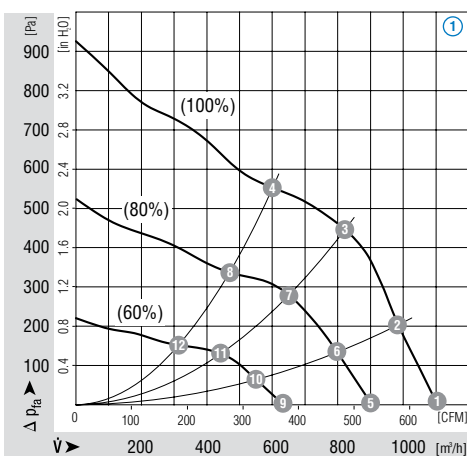

# K3G097-AK/BK BASIC Drawings

## K3G097-AK Basic Drawing

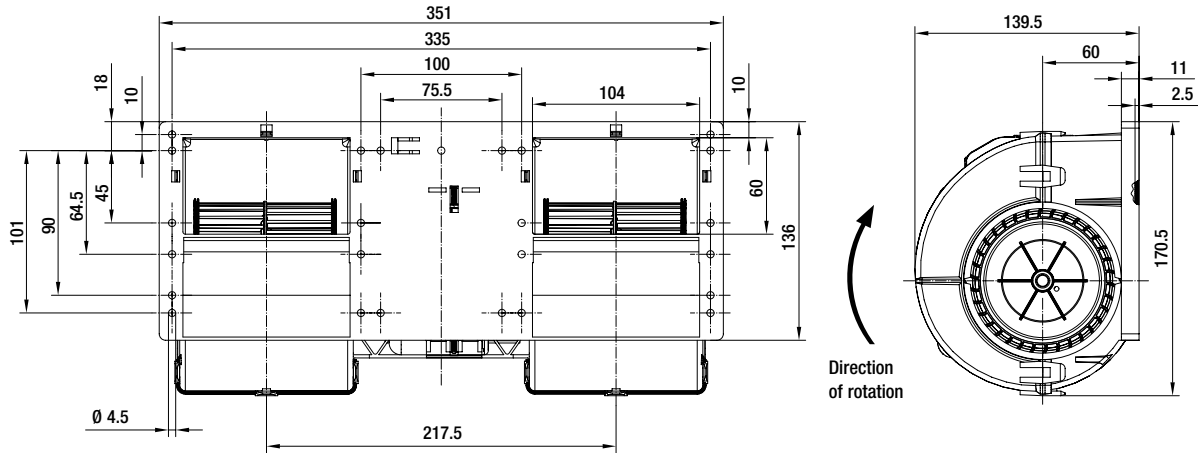

### View connector plug

- 1 = +UB
- 2 = GND
- 3 = PWM/LIN, 100 % Speed
- 4 = 80 % Speed
- 5 = 60 % Speed
- 6 = NC (not assigned)

### Speed setting

Pin	5	4	3
60%	H	NC	NC
80%	NC	H	NC
100%	NC	NC	H

NC = not assigned  
H = U<sub>N</sub> (13 V)

- 5: ~60% speed
- 3: PWM/LIN  
100% speed
- 1: +UB
- 6: NC
- 4: ~80% speed
- 2: GND

AMP Junior Power Timer, 6-pole, coded; connecting lead (450 mm) with mating plug; part no. 02001-4-1021 (not included in delivery)

## K3G097-BK Basic Drawing

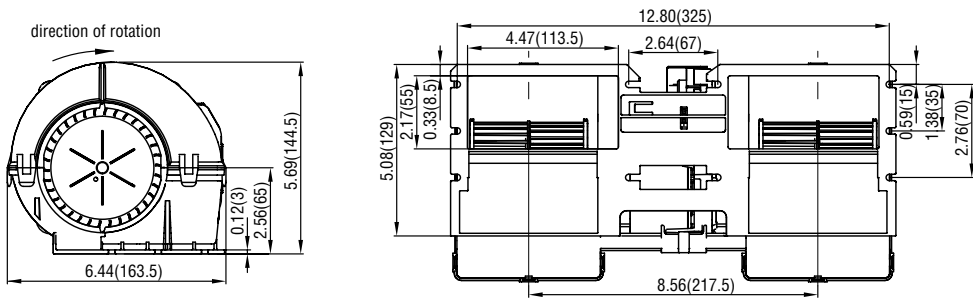

### speed setting

Pin	5	4	3
60%	H	NC	NC
80%	NC	H	NC
100%	NC	NC	H

H = U<sub>N</sub> (26 V)

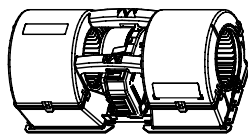
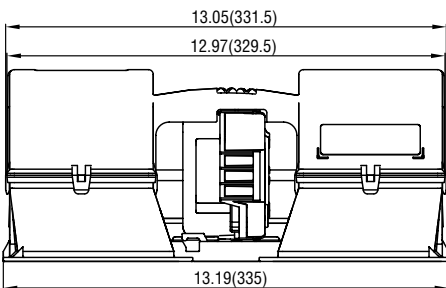

- 5: ~60% speed
- 3: PWM/LIN  
100% speed
- 1: +UB
- 6: NC
- 4: ~80% speed
- 2: GND

# Axials for Mobile Applications

ebm-papst brushless DC axial fans are the perfect solution for commercial vehicle air-conditioning and remote heat exchanger applications. Using ebm-papst brushless DC motor, these axial fans meet the increasing demands for extra comfort in buses and other vehicles while extended service intervals 4-5x that of brush design motors! This ultimately results in a substantial cost savings over time with the superior reliability only found in products from ebm-papst.

The unique blade profile of the brushless axial fans incorporates five sickle-shaped impellers with an integrated outer ring made of impact-resistant, acid and alkaline resistant plastic which results in safe performance and low noise operation, without the added weight from similar designs of sheet steel. Speed control via PWM or linear voltage, standby operation, and opposite flow protection is available upon request.

## Main Applications:

- ▶ Condenser fans for air-conditioning systems in buses & coaches
- ▶ Heat exchanger fans for agricultural and construction equipment
- ▶ Heat exchanger fans for remote applications



## W3G280 and W3G300 Features

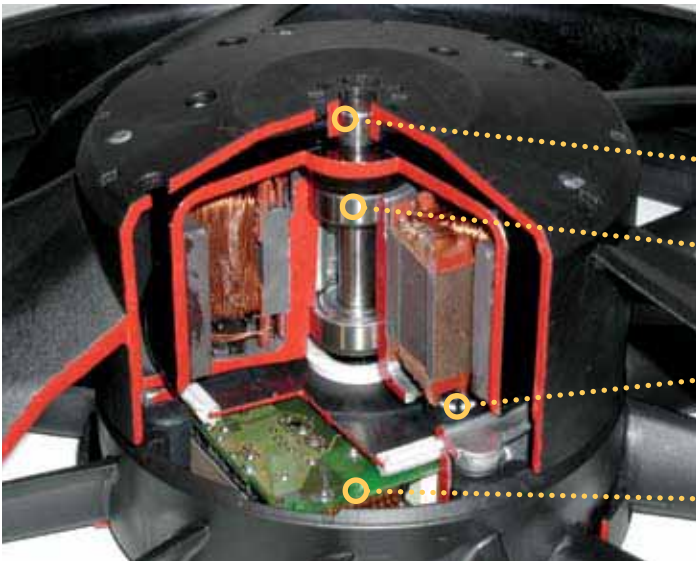

- Oversized steel shaft
- Long life brushless DC motor with ball bearing construction
- Electronic compartment “one-way” ventilation port (air in - water/dust out)
- Coated circuit board for motor commutation

# W3G280 Axial



## Ø 280mm EC Axial with Brushless DC-motor

- **Material:** Wall ring made of plastic PP, color:black; impeller made of plastic PS/SPS color: black (corresponding to UL 94 HB)
- **Insulation Class:** "B" according to EN 60335-1
- **Bearings:** Maintenance-free ball bearings
- **Motor protection:** Over-temperature protection, reverse battery and locked-rotor protection, load dump, under-voltage detection
- **EMC:** VDE 0879-2, interference suppression grade 5

Part Number	Curve	CFM @ D	Voltage	Voltage Range	Power (W)	dBA	Max Amb. Temp C	Speed (RPM)	Weight (lbs.)	Electrical Connection
W3G280-EQ08-44	1	1274	13 <sup>(2)</sup>	9-15	152	68	85	2830	5.30	D
W3G280-EQ20-43	2	1412	26 <sup>(1)</sup>	16-32	200	72	85	3100	5.29	B

<sup>(1)</sup> 12-volt variant

<sup>(2)</sup> 24-volt variant

	n [rpm]	P <sub>1</sub> [W]	η <sub>ges</sub> [%]	Lp <sub>A</sub> [dBA]
① ①	2830	152	31	68
① ②	2840	152	39	70
① ③	2845	150	40	72
① ④	2805	158	34	71

	n [min <sup>-1</sup> ]	P <sub>1</sub> [W]	η <sub>ges</sub> [%]	Lp <sub>A</sub> [dBA]
② ①	3100	200	34	72
② ②	3085	197	40	72
② ③	3090	192	42	74
② ④	3105	213	37	76

### Curve

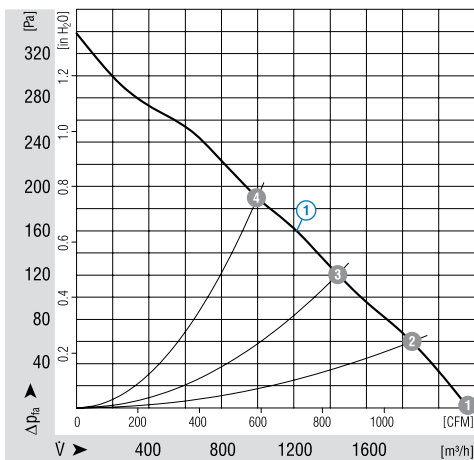

### Curve

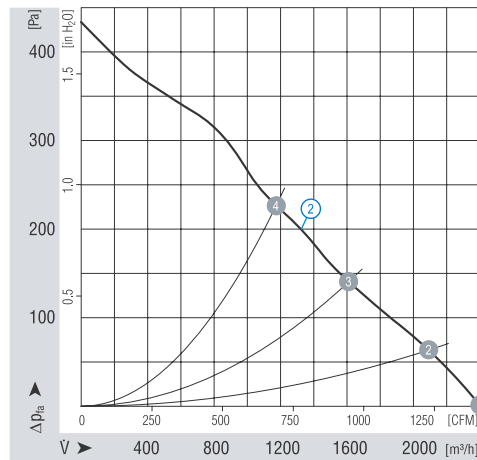

# W3G300-EQ Axial



## Ø 300mm EC Axial Fan with Brushless DC motor

- **Material:** Scroll housing made of plastic PP - color black, impeller made of plastic PA - color black (corresponding to UL 94 HB)
- **Insulation Class:** "B" according to EN 60335-1
- **Bearings:** Maintenance-free ball bearings
- **Motor protection:** Over-temperature protection, reverse battery and locked-rotor protection, load dump, under-voltage detection
- **EMC:** VDE 0879-2, interference suppression grade 5

Part Number	Curve	CFM @ 0	Voltage	Voltage Range	Power (W)	dBa	Max. Amb. Temp. C	Speed (RPM)	Weight (lbs.)	Electrical Connection
W3G300-EQ28-56	1	1918	27 <sup>(2)</sup>	15-32	320	75	85	3380	5.51	B
W3G300-EQ30-43	2	1609	26 <sup>(2)</sup>	16-32	180	71	85	2840	5.51	C
W3G300-EQ42-44	3	1500	13 <sup>(1)</sup>	9-15	152	69	70	2650	5.51	D

<sup>(1)</sup> 12 V variant

<sup>(2)</sup> 24 V variant

	n [min <sup>-1</sup> ]	P <sub>1</sub> [W]	η <sub>ges</sub> [%]	L <sub>pA</sub> [dBA]
① ①	3380	320	38	75
① ②	3380	328	47	77
① ③	3380	334	47	78
① ④	3360	370	38	81

	n [min <sup>-1</sup> ]	P <sub>1</sub> [W]	η <sub>ges</sub> [%]	L <sub>pA</sub> [dBA]
② ①	2840	180	39	71
② ②	2810	188	47	72
② ③	2795	189	47	75
② ④	2715	205	37	75

	n [rpm]	P <sub>1</sub> [W]	η <sub>ges</sub> [%]	L <sub>pA</sub> [dBA]
③ ①	2650	152	36	69
③ ②	2625	156	44	70
③ ③	2615	156	44	72
③ ④	2570	168	36	73

Curve

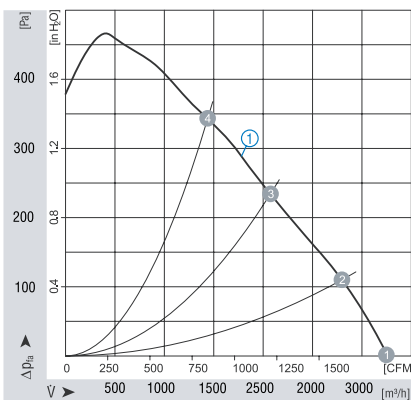

Curve

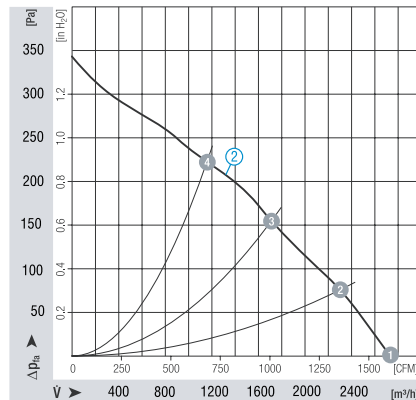

Curve

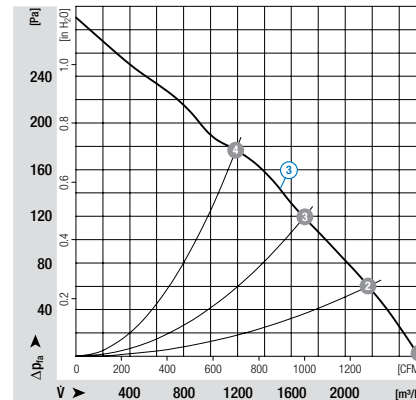

# W3G280 / W3G300-EQ Drawings

## W3G280 Axial Drawing

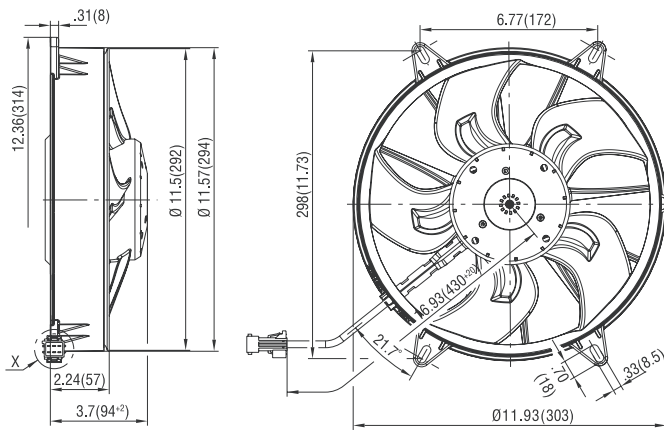

Airflow Direction "V" "PUSHER FAN"

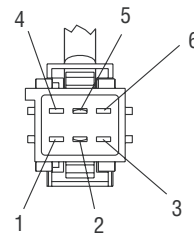

View X

- 1 = UN black
- 2 = GND brown
- 3 = PWM/LIN yellow
- 4 = INVLIN orange
- 5 = lower speed blue
- 6 = diagnostic output white

AMP Junior Power Timer, 6-pole, coded; connection lead (450 mm) with mating plug (part no. 02002-4-1021 not included)

## W3G300-EQ Axial Drawing

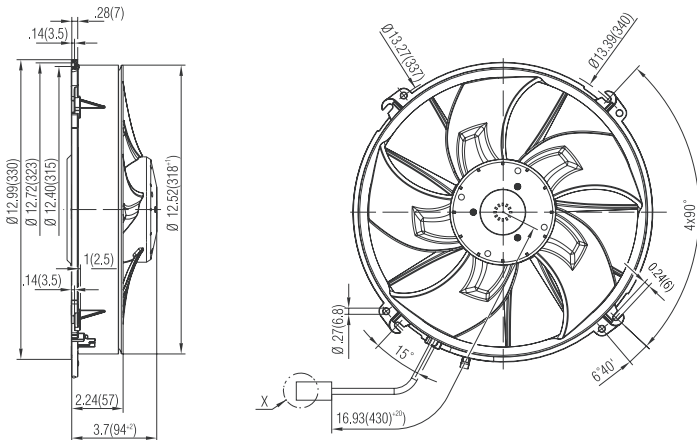

Airflow Direction "V" "PUSHER FAN"

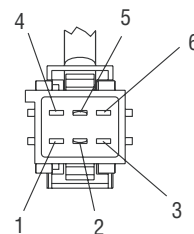

View X

- 1 = UN black
- 2 = GND brown
- 3 = PWM/LIN yellow
- 4 = INVLIN orange
- 5 = lower speed blue
- 6 = diagnostic output white

AMP Junior Power Timer, 6-pole, coded; connection lead (450 mm) with mating plug (part no. 02002-4-1021 not included)

# W3G300-ER Axial



## Ø 300mm EC Axial Fan with Brushless DC motor

- **Material:** Scroll housing made of plastic PP - color black, impeller made of plastic PA - color black (corresponding to UL 94 HB)
- **Insulation Class:** "B" according to EN 60335-1
- **Bearings:** Maintenance-free ball bearings
- **Motor protection:** Over-temperature protection, reverse battery and locked-rotor protection, load dump, under-voltage detection
- **EMC:** VDE 0879-2, interference suppression grade 5

Part Number	Curve	CFM @ 0	Voltage	Voltage Range	Power (W)	dBA	Max. Amb. Temp. C	Speed (RPM)	Weight (lbs.)	Electrical Connection
W3G300-ER38-45	1	1845	27.5 <sup>(1)</sup>	16-32	335	87	85 <sup>(2)</sup>	3320	5.51	C
			<sup>(1)</sup> 24 V variant		<sup>(2)</sup> free blowing, not recommended for non-stop operation at 85° C					

	n [rpm]	P <sub>1</sub> [W]	η <sub>tot</sub> [%]	LP <sub>A</sub> [dBA]
①	3320	335	32	87
②	3295	354	42	85
③	3255	367	45	86

### Curves

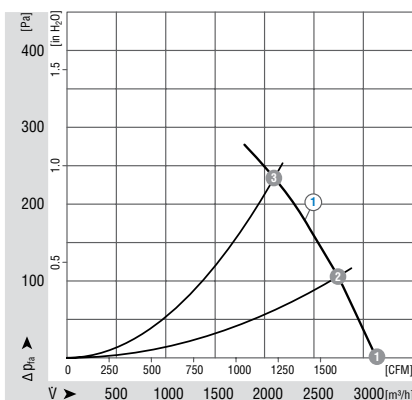

# W3G300-ER Drawing

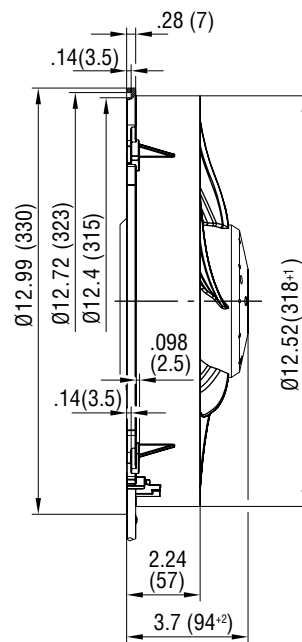
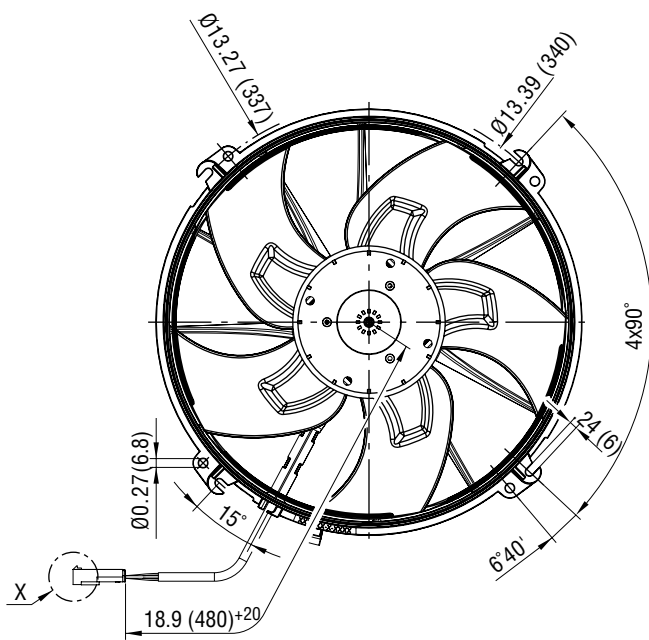

“A” >

Airflow Direction “A” “PULLER FAN”

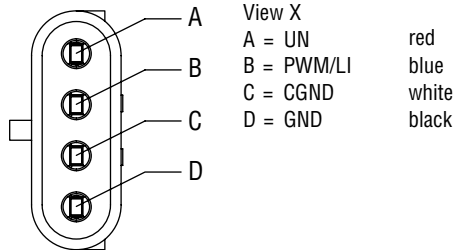

# EC Centrifugal Fans For Mobile Applications



## Ø 220 / 250mm Backward Curved, EC Centrifugal Fans

- **Material:** Impeller<sup>(1)</sup> completely made of PA 6.6 GV plastic, injection-molded round sheet-metal plate  
Impeller<sup>(2)</sup> made of PA 6.6 GV plastic, round sheet-metal plate
- **Direction of rotation:** Clockwise, as seen on rotor
- **Insulation class:** "B" in accordance with EN 60335-1
- **Mounting position/condensate discharges:** Rotor on bottom with condensate discharge holes is standard
- **Bearings:** Maintenance-free ball bearings
- **Technical features:** Control input 0-10 VDC / PWM, tach output
- **Motor protection:** reverse polarity and locked-rotor protection
- **Cable exit:** variable

Part Number	Curve	CFM @ 0	Voltage	Voltage Range	Power (W)	dBA	Max. Amb. Temp. C	Speed (RPM)	Weight (lbs.)	Electrical Connection
R1G220-AB35-92 <sup>(1)(3)</sup>	1	621	24	16-28	106	76	60	3150	3.09	E
R1G250-AQ21-42 <sup>(2)(3)</sup>	2	671	24	16-28	93	73	60	2540	4.41	E

<sup>(3)</sup> Also possible as 12 V variant

	n [rpm]	P <sub>1</sub> [W]	η <sub>IL</sub> [%]	Lp <sub>A</sub> [dBA]		n [rpm]	P <sub>1</sub> [W]	η <sub>IL</sub> [%]	Lp <sub>A</sub> [dBA]
① ①	3400	128	---	78	① ⑤	2470	50	---	70
① ②	3200	132	53	69	① ⑥	2360	54	53	63
① ③	3050	135	55	67	① ⑦	2300	57	55	59
① ④	3000	137	46	71	① ⑧	2250	59	46	63
① ①	3150	106	---	76					
① ②	3010	110	53	68					
① ③	2870	112	55	65					
① ④	2800	113	46	69					

	n [rpm]	P <sub>1</sub> [W]	η <sub>IL</sub> [%]	Lp <sub>A</sub> [dBA]		n [rpm]	P <sub>1</sub> [W]	η <sub>IL</sub> [%]	Lp <sub>A</sub> [dBA]
② ①	2790	124	---	75	② ⑤	1940	42	---	68
② ②	2530	132	55	68	② ⑥	1810	49	55	62
② ③	2500	134	58	63	② ⑦	1790	50	58	57
② ④	2560	131	48	66	② ⑧	1820	49	48	59
② ①	2540	93	---	73					
② ②	2370	105	55	66					
② ③	2330	108	58	62					
② ④	2382	105	48	64					

### Curves

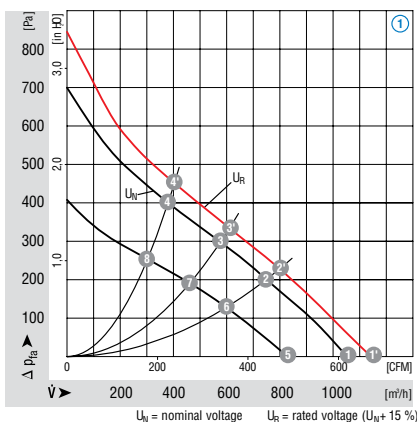

### Curves

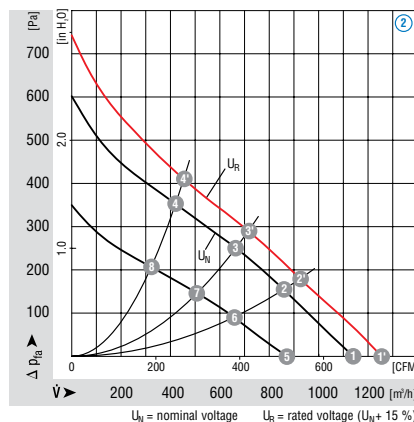

# R1G220 / 250 Drawing

Part Number	Dimensions							Dimensions				
	a	b	c	d	f	g	k	Inlet nozzle	o	r	u	v
R1G220-AB35-92	8.66 (220)	2.52 (64.0)	2.8 (71)	2.56 (65)	6.26 (159)	1.73 (44)	1.29 (32.7)	09609-2-4013	0.84 (21)	0.87 (22)	6.10 (155.0)	9.92 (252)
R1G250-AQ21-42	9.84 (250)	2.86 (73.3)	3.5 (89)	2.95 (75)	6.77 (172)	1.77 (45)	12.20 (31.0)	96359-2-4013	1.22 (31)	1.10 (28)	6.48 (164.5)	10.04 (255)

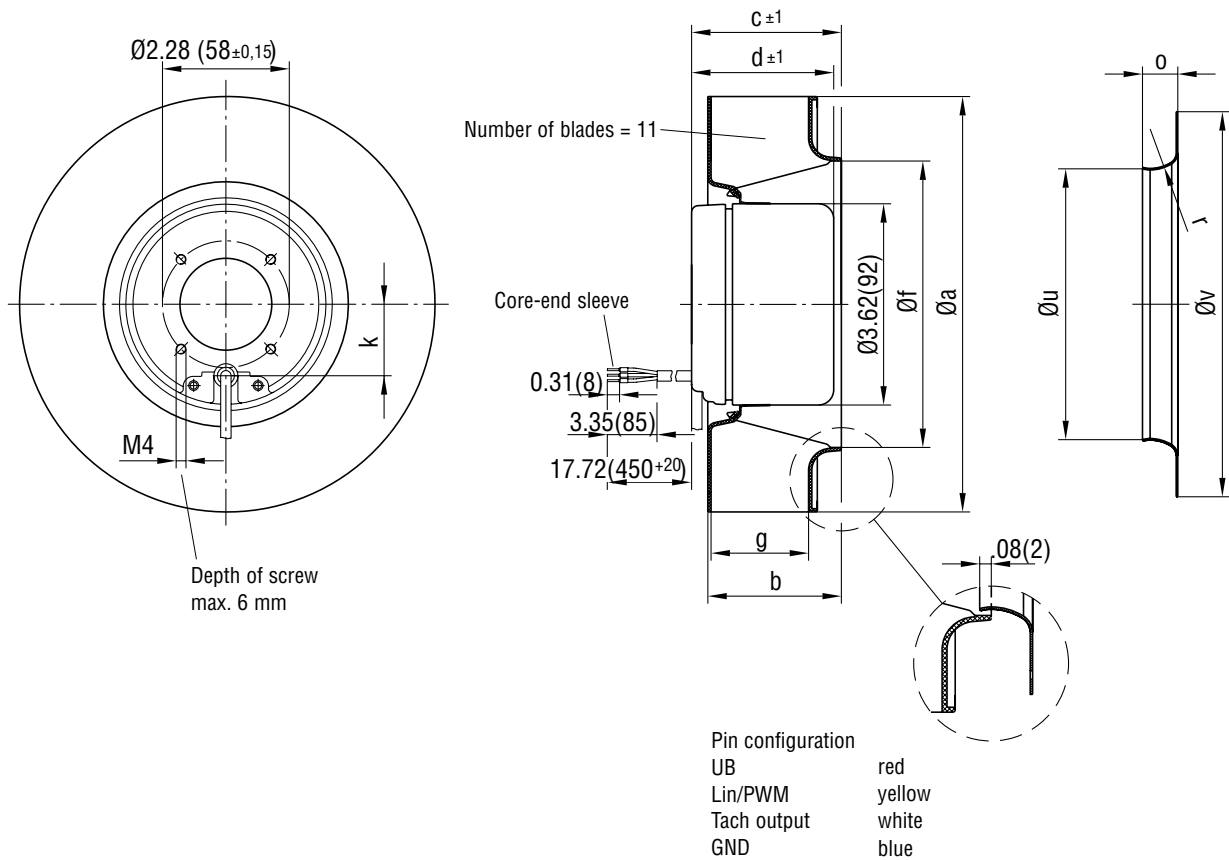

# Accessories

## power cord reference

ebm-papst Air Mover Part Number	ebm-papst Power Cord Part Number	Wiring Diagram	Diagram Page
K3G097-AK32-42	N/A (blower has wire leads)	A	25
K3G097-AK36-55	N/A (blower has wire leads)	A	25
K3G097-AK34-43	02001-4-1021	B	25
K3G097-BK32-42	N/A (blower has wire leads)	A	25
K3G097-BK36-56	N/A (blower has wire leads)	A	25
K3G097-BK34-43	02001-4-1021	B	25
K3G097-AK34-65	02001-4-1021	F	27
K3G097-AK32-70	02001-4-1021	F	27
K3G097-AK32-70	02001-4-1021	F	27
W3G280-EQ08-44	02002-4-1021	D	26
W3G280-EQ20-44	02002-4-1021	B	25
W3G300-EQ28-56	* See Note	C	26
W3G300-EQ30-43	02002-4-1021	B	25
W3G300-EQ42-44	02002-4-1021	D	26
W3G300-ER38-45	* See Note	C	26

\* Mating Packard (4 contact) Plug part number 12015797  
 Power Sockets part number 12124580  
 Control Sockets part number 12089188

Part Number	Application
02001-4-1021	EC twin-centrifugal blower
02002-4-1021	EC axial fan

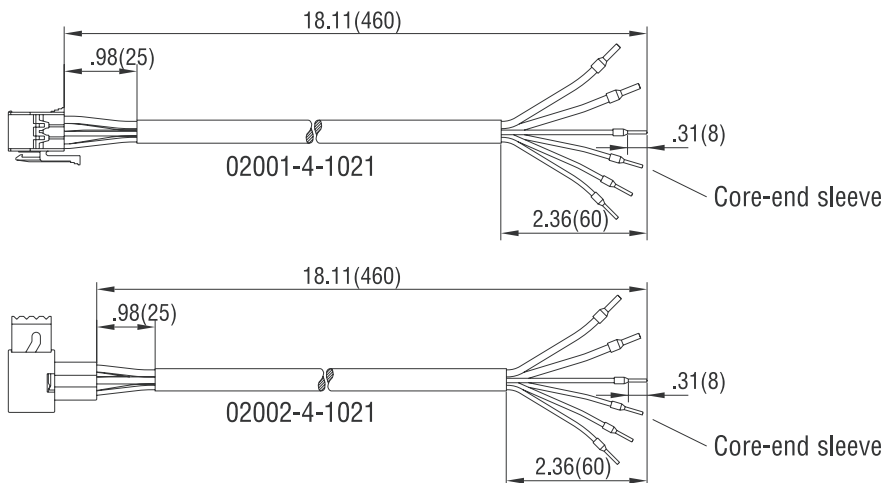

# Electrical Connections

## A) 13 VDC electrical connection (EC dual centrifugal blowers "Premium")

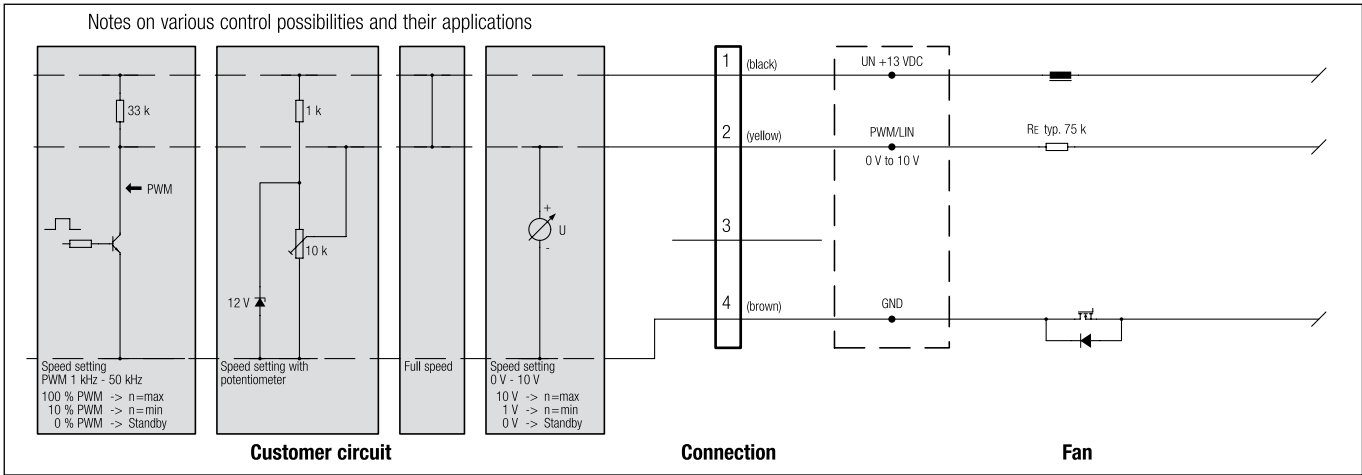

## B) 26 VDC electrical connection

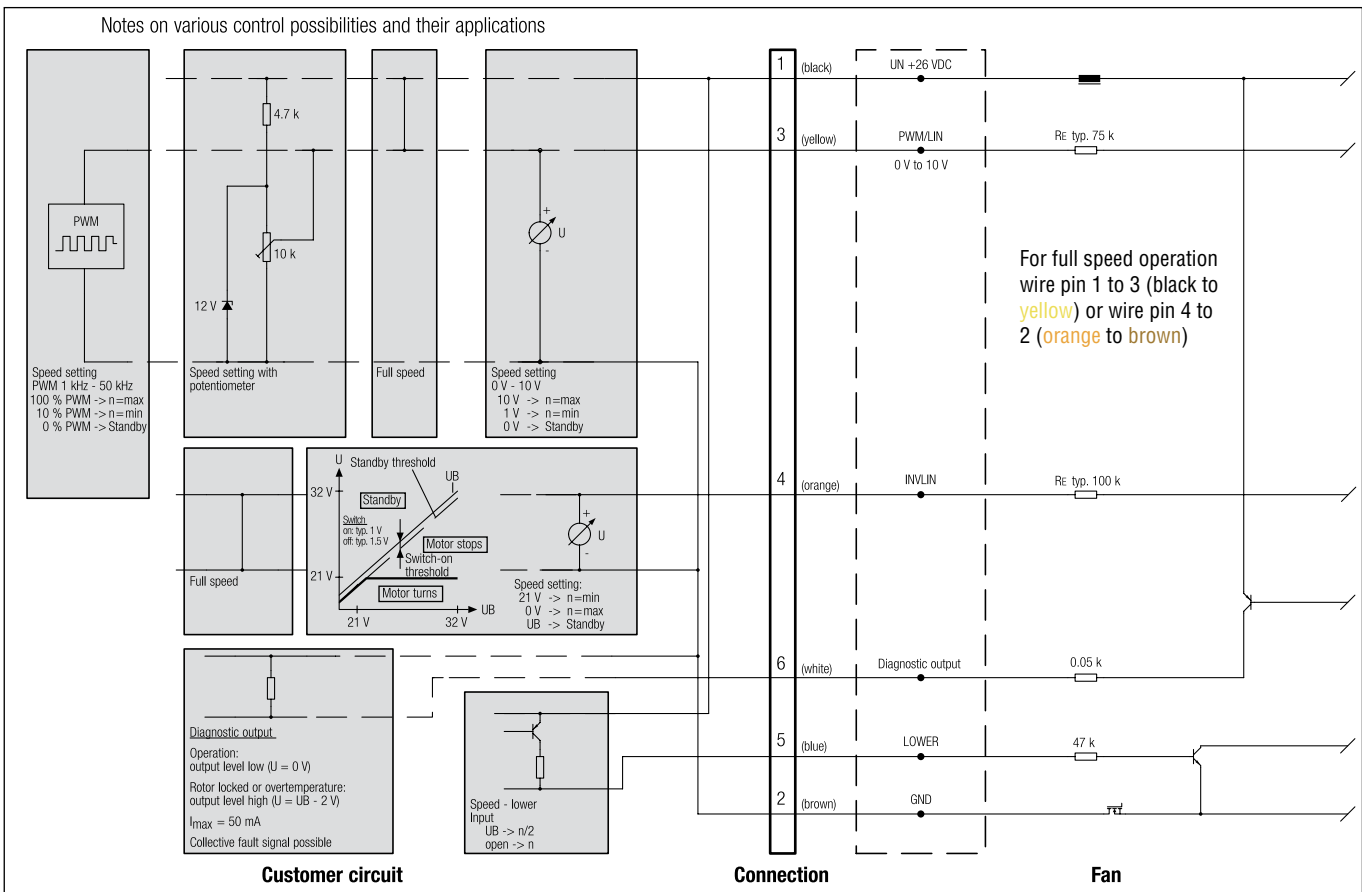

# Electrical Connections

## C) 27.5 VDC electrical connection

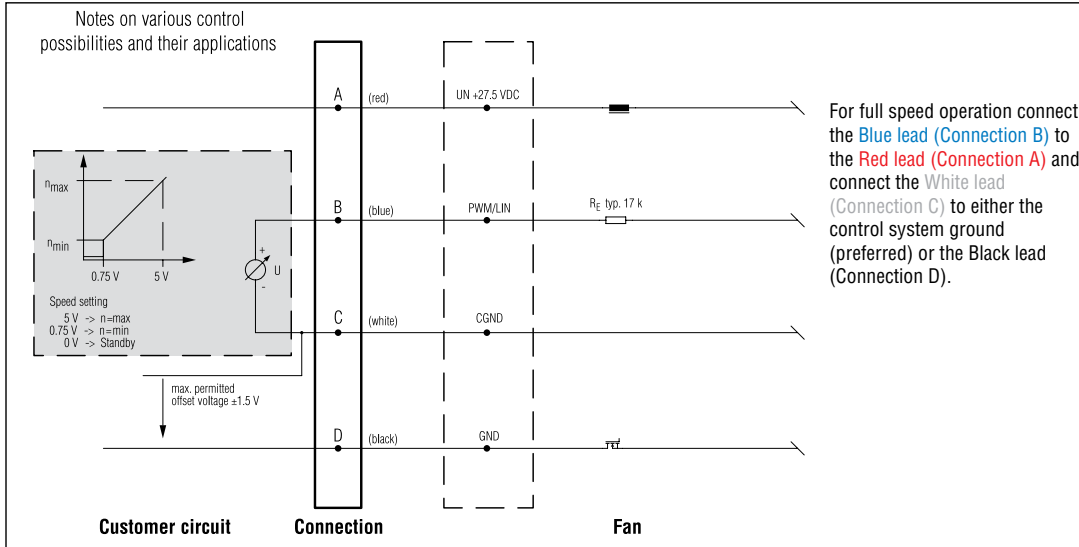

## D) 13 VDC electrical connection (EC axial fans)

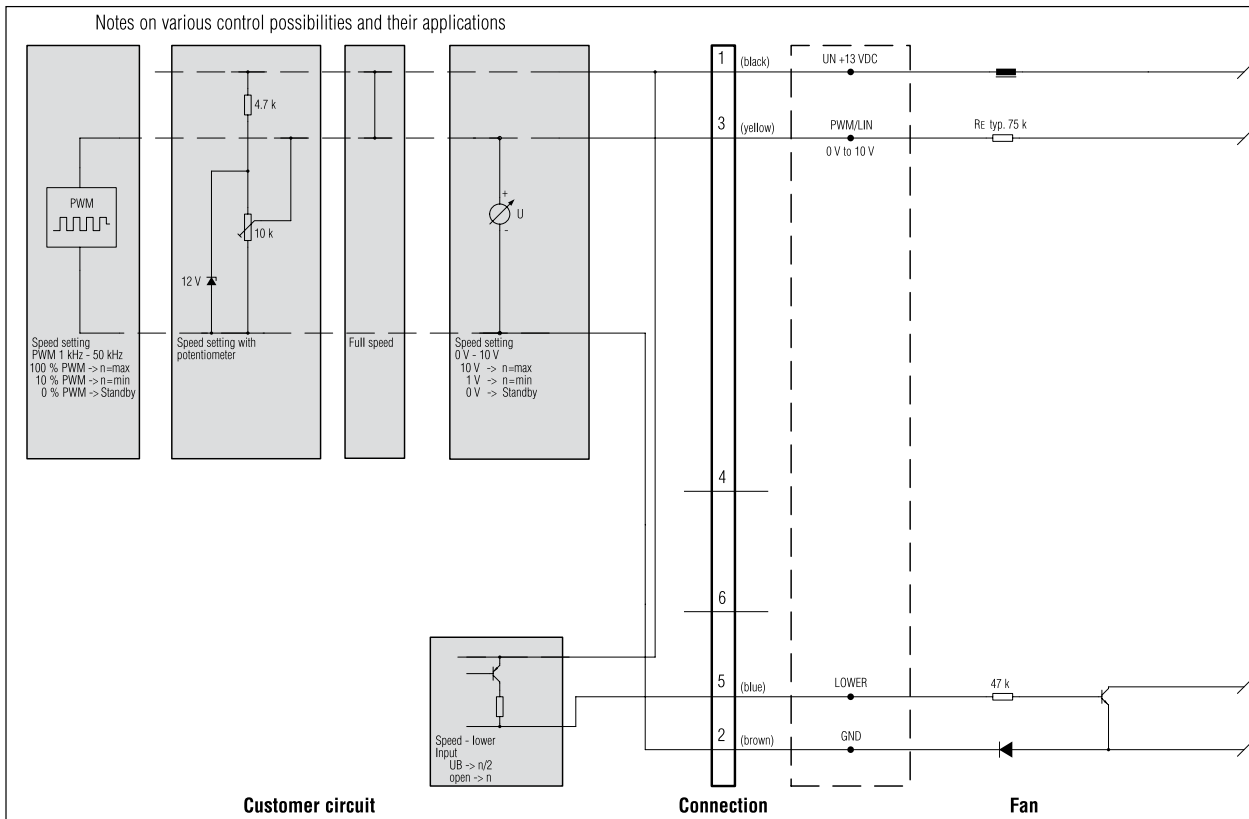

# Electrical Connections

## E) 24 VDC electrical connection

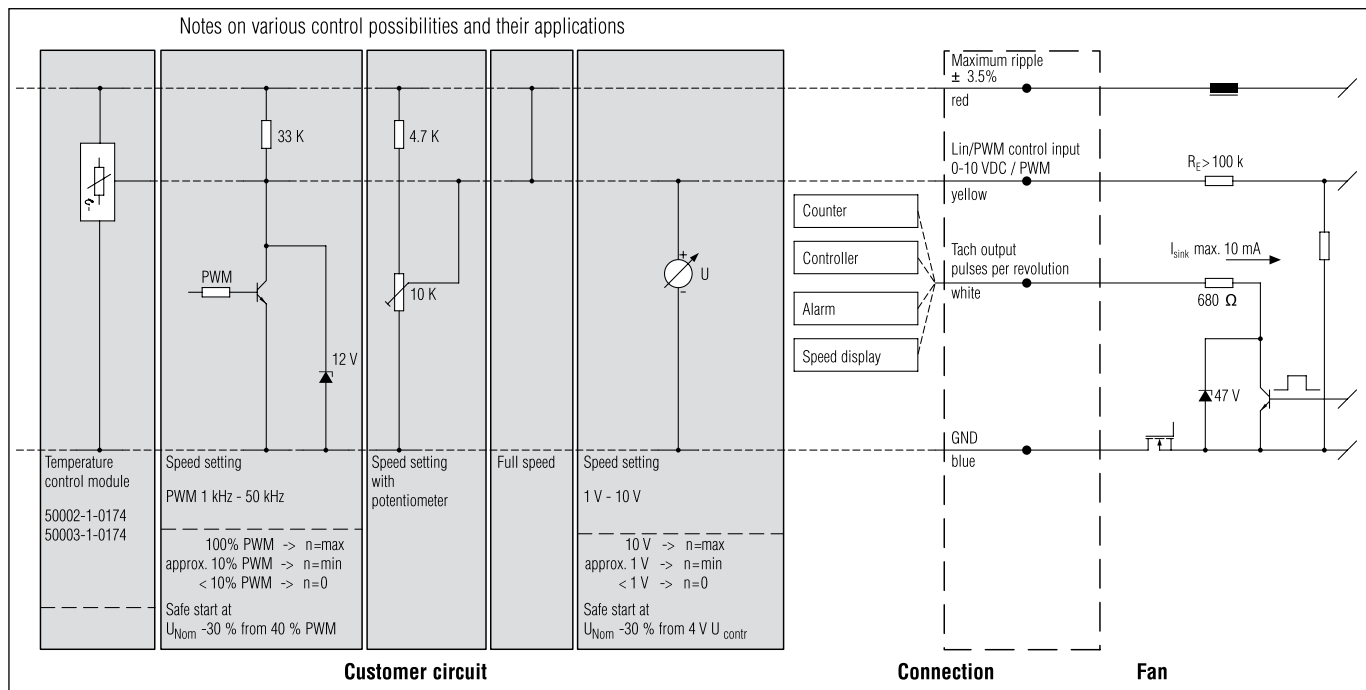

## F) 13 or 26 electrical connection (EC dual centrifugal blowers "Basic")

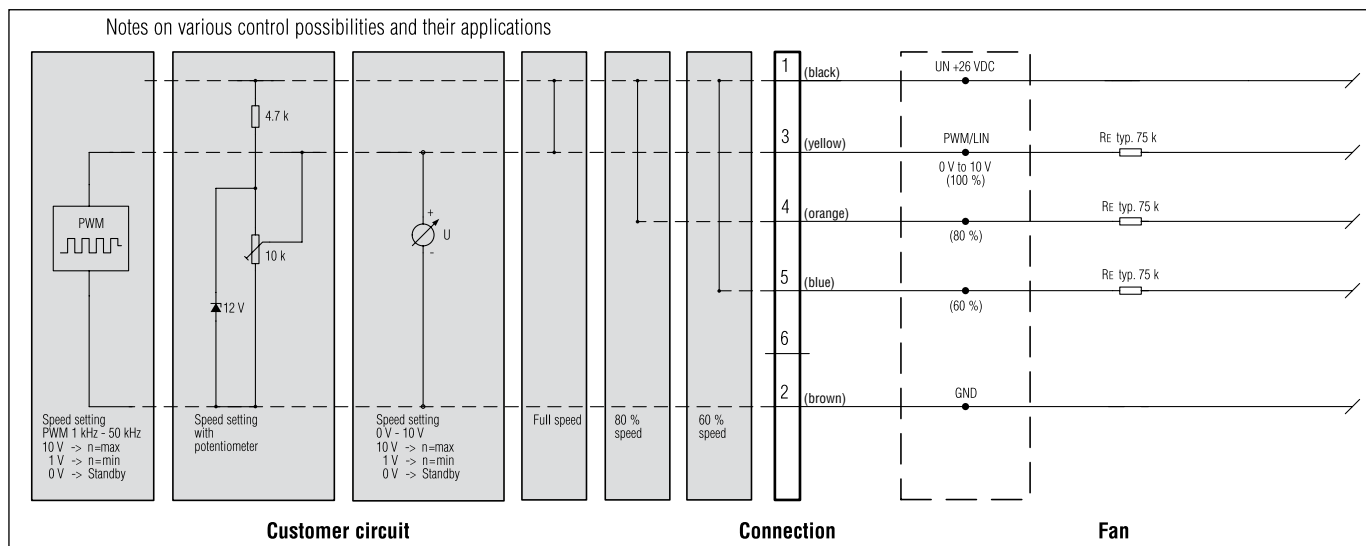

ebm-papst Inc.

100 Hyde Road  
Farmington, CT 06034  
USA

Phone: 860-674-1515  
Fax: 860-674-8536  
sales@us.ebmpapst.com  
www.ebmpapst.us