

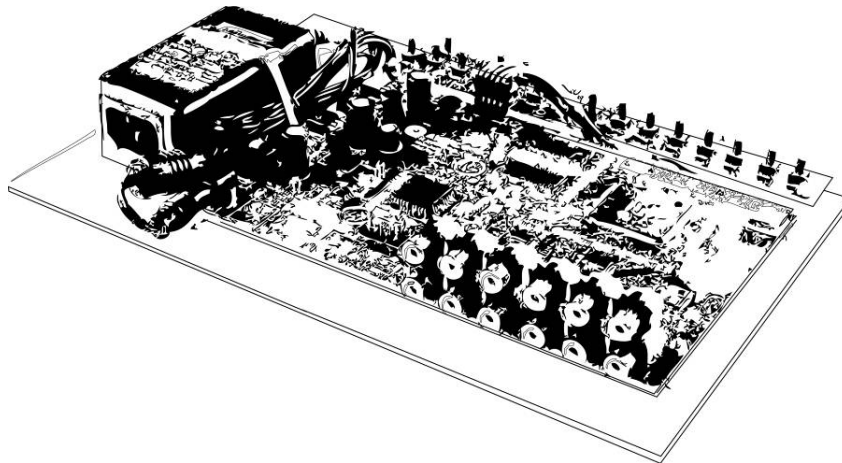

# **AL37219C-EVB-A2 Evaluation Board**

**User Manual  
Version 1.1**



**INFORMATION FURNISHED BY AVERLOGIC IS BELIEVED TO BE ACCURATE AND RELIABLE. HOWEVER, NO RESPONSIBILITY IS ASSUMED BY AVERLOGIC FOR ITS USE, OR FOR ANY INFRINGEMENTS OF PATENTS, OR OTHER RIGHTS OF THIRD PARTIES THAT MAY RESULT FROM ITS USE. NO LICENSE IS GRANTED BY IMPLICATION OR OTHERWISE UNDER ANY PATENT OR PATENT RIGHTS OF AVERLOGIC.**

DOC Number:1-M-PAE319-0201



## Table of Contents

<b>1 Introduction</b> .....	<b>1</b>
1.1 Product Description .....	1
1.2 Package Contents .....	2
1.3 Block Diagram .....	2
1.4 Specifications .....	2
1.5 EVB Features .....	3
<b>2 Quick Setup</b> .....	<b>4</b>
2.1 Attach camera (CVBS RCA connector) .....	5
2.2 Attach TV monitor (CVBS RCA connector).....	5
2.3 Attach power cable.....	5
2.4 Turn on the board power .....	5
2.5 If no video appears .....	6
<b>3 Hardware Section</b> .....	<b>7</b>
3.1 Product Description .....	7
3.2 Rear Panel I/O Port Descriptions .....	8
3.3 Reset Button.....	8
3.4 Keypad Panel .....	8
<b>4 System Menu</b> .....	<b>10</b>
4.1 OSD Main Menu.....	10
4.2 Navigating the OSD Menu using the Keypad.....	10
4.3 System Submenu .....	11
4.4 Channel Submenu.....	12
4.5 PIP Submenu .....	12
4.6 POP Submenu .....	13
4.7 Auto Sequence Submenu .....	14
4.8 Time Submenu .....	14
4.9 Alarm Submenu.....	15
<b>5 Remote Control</b> .....	<b>16</b>
5.1 Remote Control Button Description.....	16

# 1 Introduction

## 1.1 Product Description

The AL37219 Video Processor EVB is an evaluation product that demonstrates a total solution for video surveillance applications using AverLogic IC chips. This EVB product can receive video streams from up to 9 cameras and can simultaneously display the video on a monitor in a variety of convenient display formats.

The main components include three video decoders (AL244) and a video processor (AL37219). The video decoders process 9 channels of analog video, which are converted to digital for video playback by the video processor (AL37219). It is a low-cost, easy-to-install solution for real-time video surveillance applications that need to manage 9-channel video output to TV monitors, VCRs and digital storage devices.

The AL37219 video processor provides nine analog CVBS video input connectors. It has cost-effective, high-quality NTSC/PAL video decoding technology with adaptive comb-filter Y/C separation processing. It is also equipped with BCS (Brightness, Contrast, Saturation and Hue) control, Scale-Down Function, Re-play function, Zoom, Freeze, Internal OSD overlay, Motion Detection and PIP/POP display capabilities for monitoring video surveillance devices.

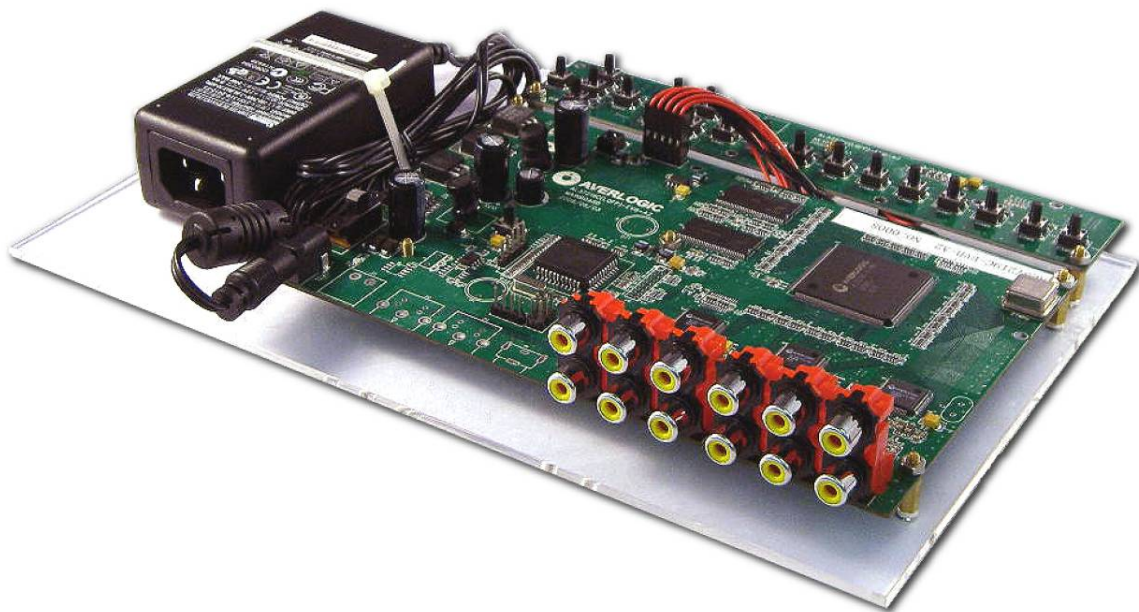

## 1.2 Package Contents

Please check the package contents and notify any discrepancies or damage to your distributor immediately.

- AL37219 Mainboard with DC Adaptor
- 10 RCA cables (CVBS)
- Power Cord
- Remote Control Unit
- User Manual (not shown)

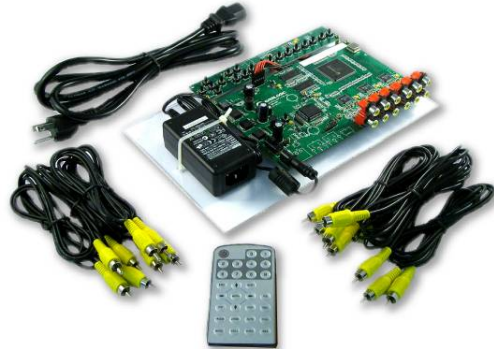

## 1.3 Block Diagram

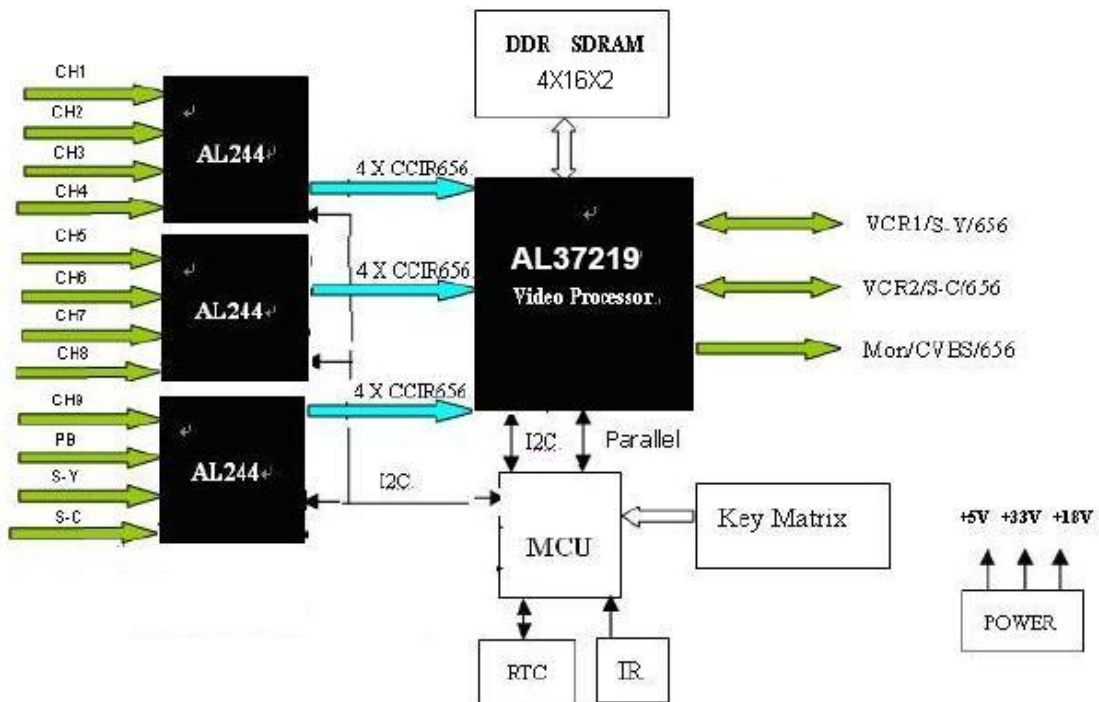

## 1.4 Specifications

- Video Standard Support: NTSC and PAL
- Video Input Standard: CVBS
- Video Output Standard: CVBS



## 2 Quick Setup

The AL37219-EVB-A2 product installation is fast and easy. In addition to the product packaging contents, you will need to provide a monitor that uses CVBS connections and at least one camera that is also equipped with a CVBS output connector. The setup diagram is shown below:

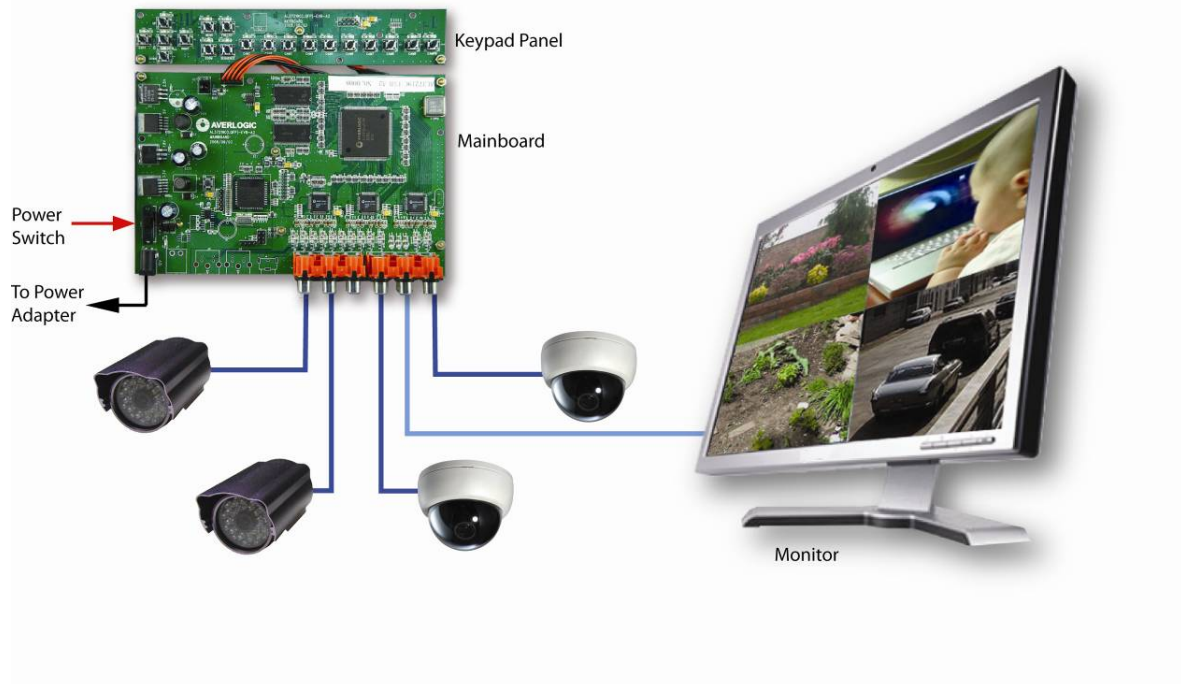

### 2.1 Attach camera (CVBS RCA connector)

First attach your camera to one of the nine video input connectors on the rear panel. Turn on the camera and begin transmitting video.

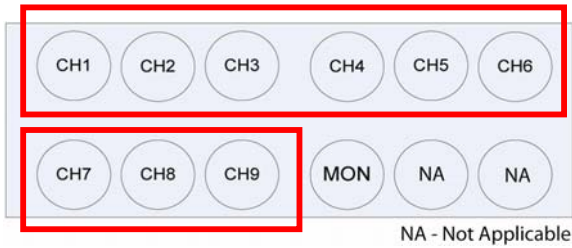

### 2.2 Attach TV monitor (CVBS RCA connector)

Attach your monitor to the monitor connector located on the rear panel (as shown). Turn on your monitor.

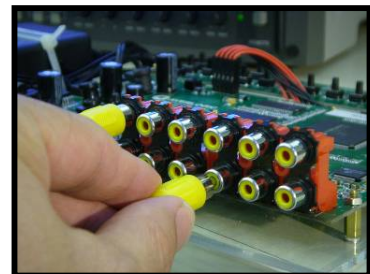
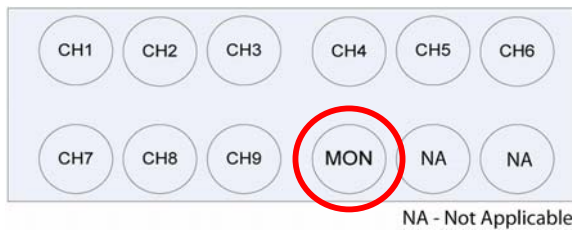

### 2.3 Attach power cable

Attach one end of the power cable to the adapter and the other end to a wall socket with the appropriate voltage.

Note: The power adapter should already be attached to the mainboard when you receive the product.



### 2.4 Turn on the board power

Toggle the power switch, which is located on the main board near the power adapter connector. A yellow-green LED next to the power switch will illuminate.



Your monitor should soon begin to display the video images that your camera is transmitting in one of the display boxes on the screen.



## 2.5 If no video appears ...

- Make sure that all power cables are securely fastened (for monitor, camera and board).
- Make sure the RCA connection between monitor to board is secure.
- Make sure RCA connection between camera and board is secure.
- Make sure that the monitor is in working order.
- Make sure that the camera is in working order and is delivering video.
- Make sure that the video standard (NTSC or PAL) used between camera and board is the same (to check board video standard, refer to the Systems Menu section – Systems Submenu).

# 3 Hardware Section

## 3.1 Product Description

This product consists of a Mainboard and Keypad Panel. A Power Adapter and cables are also supplied. The only components on the Mainboard to note are the Power Switch, Power connector, Reset Switch and the Rear Panel connectors.

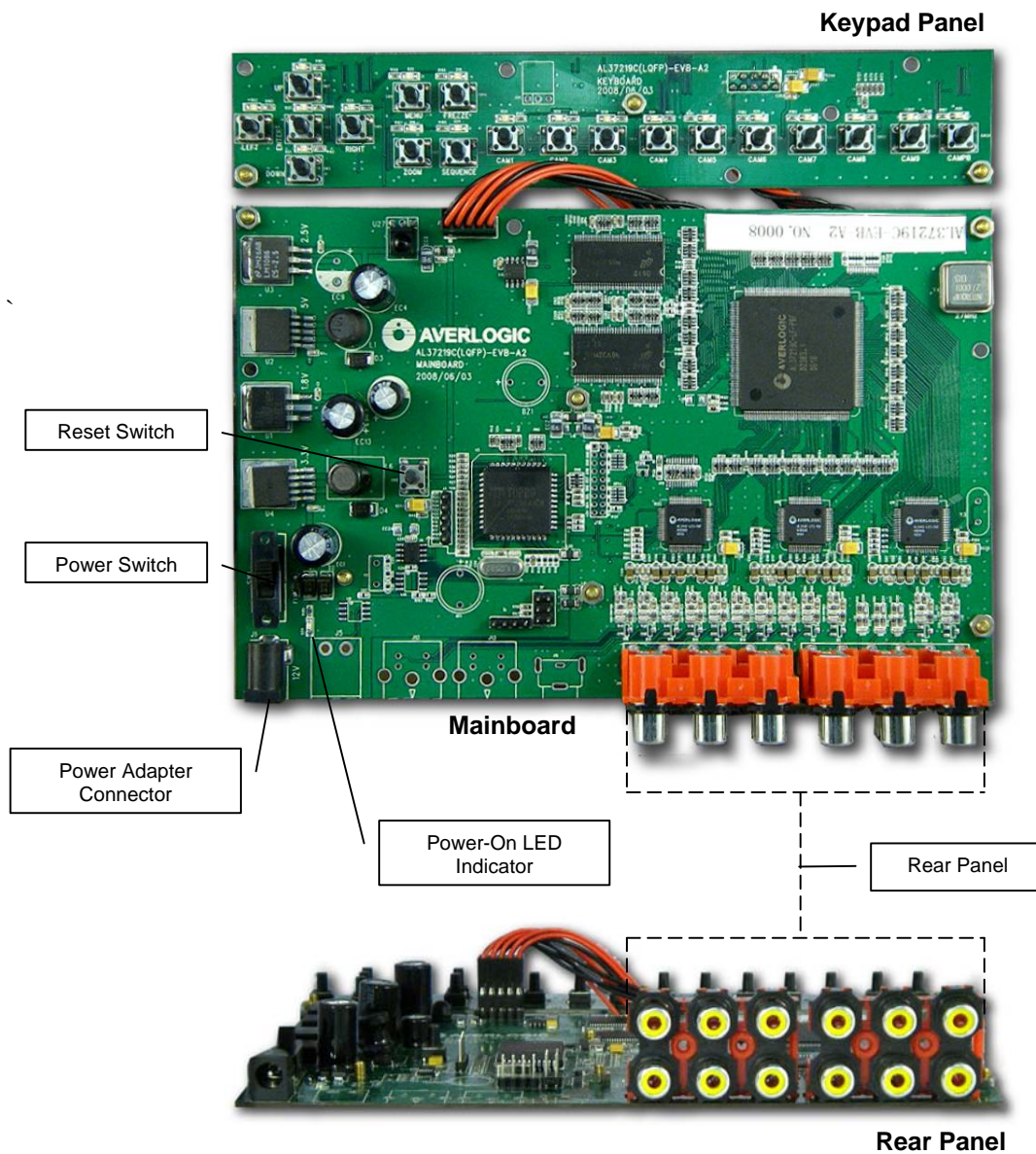

**Note:** The jumpers and connectors on this EVB board that are not described are either disabled or not meant for use.

### 3.2 Rear Panel I/O Port Descriptions

The rear panel contains input and output connectors for cameras and monitors.

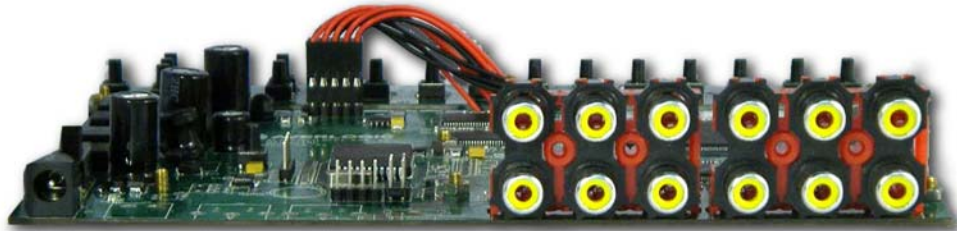

Rear Panel



NA - Not Applicable

Connector	Description
CH1-CH9.	These connectors are CVBS connectors designated for video input from up to 9 cameras
MON.	This connector is an output connector for a monitor with a CVBS line

### 3.3 Reset Button

In the event the EVB has entered an unstable state, you can press the reset button (marked SW2 on Mainboard) to reset the EVB.

### 3.4 Keypad Panel



Key	Function
UP/FULL	This key has two functions. It serves as the “Up” navigation key on the OSD menu. Otherwise, you can press this key at anytime for Full Screen video camera display. The default camera for this button can be configured in the POP section of the OSD menu.
ENTER/PIP	This key has two functions. It serves as an “Enter” key on the OSD screen (i.e drill down to a submenu or move up to the Main Menu). Otherwise, you can press this key at anytime to enter PIP (picture-in-picture) display mode. PIP display mode is configured from the OSD menu (see OSD Main Menu. PIP submenu).
DOWN/3x3	This key has two functions. It serves as a “Down” navigation key on the OSD menu. Otherwise, you can press this key anytime to enter the 9-channel display mode which is a 3x3 array displaying video from 9 cameras. This display can be configured in the POP submenu of the OSD menu (item 9CH).
LEFT/POP	This key has two functions. It serves to flip (backwards) through the available selections of an option on the OSD submenu. Otherwise, you can press this key at anytime to display the POP (picture-on-picture) display mode. You can configure the POP screen from the OSD menu.
RIGHT/QUAD	This key has two functions. It serves to flip (forwards) through the available selections of an option on the OSD submenu. Otherwise, you can press this key at anytime to access the Quad Display Screen which displays video from 4 cameras. This display can be configured in the POP submenu of the OSD menu.
MENU	This key allows you to enter and exit the OSD menu
FREEZE / RIGHT SHIFT	This key has two functions. First, it serves as a tab key when navigating to different fields in an OSD submenu line. Otherwise, this key allows you to freeze all video on the display screens.
ZOOM	This key allows you to zoom-in on the video image in any display mode. The zoom scaling goes from x1 to x2 to x4 to x8 and then back to x1.
SEQUENCE/ LEFT SHIFT	The Auto Sequence button is used to automatically display images from different cameras in sequence, one after the other, in full screen mode. The Auto Sequence camera images to be displayed can be configured in the OSD menu (Auto Sequencing).
CAM1-CAM9	These 9 keys are associated with the 9 cameras that can be attached to this board. When you press one of these keys, the full screen video image from the associated camera will display.
CAMPB	Reserved for future use

# 4 System Menu

## 4.1 OSD Main Menu

You can bring up the OSD (On Screen Display) Main Menu by pressing the MENU key on the Keypad panel. The OSD screens are used to configure various aspects of the mainboard and display screens.

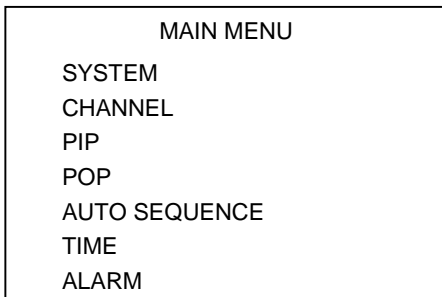

## 4.2 Navigating the OSD Menu using the Keypad

Once you have entered the OSD Menu, you can use the Keypad Panel to navigate the menu and submenus. Navigation keys are explained below:

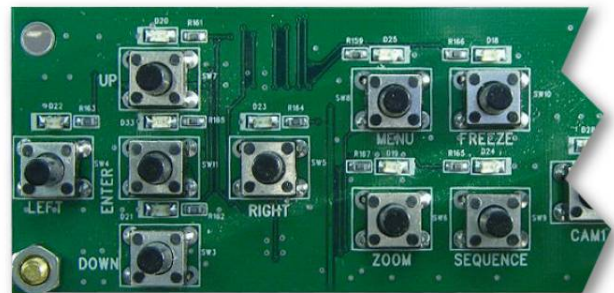

Key	Function
ENTER Key	This key is used to drill down into a submenu or exit from a submenu.
MENU Key	This key is used to initially bring up the OSD main menu. This key is also used to exit from the OSD menu.
UP/DOWN Keys	These keys are used to move up and down the menus.
FREEZE Key	This key is used as a <b>Tab</b> key to move forward (horizontally) through the different option fields of a configuration line item. This only applies to configuration line items that have more than one field.
Sequence Key	This key is used as a <b>Tab</b> key to move backward (horizontally) through the different option fields of a configuration line item. This only applies to configuration line items that have more than one field.
LEFT/RIGHT Keys	These keys are used to flip through the different selections for an option field (RIGHT-forward, LEFT-backward).

### 4.3 System Submenu

The System configuration screen allows you to set general, system related options. As with the Main Menu, you can use the UP/DOWN keys to highlight the configuration item you want to configure. Then use the LEFT/RIGHT arrow keys to flip through the different options for that item.

SYSTEM	
BORDER	YELLOW
VIDEO FORMAT	NTSC
MIRROR FLIP	OFF
SYSTEM RESET	



Option	Description
Border	Allows you to change the screen border line color. Options: White, Gray, Yellow, Red
Video Format	Sets the Video Standard used by this board. Options: PAL or NTSC. You may have to power down or press the Reset button for the change to take effect.
Mirror & Flip Settings	Sets the orientation of image on the screen. Options: F – is a vertical flip (upside down) M – horizontal flip (mirror image) MF – both horizontal/vertical flip OFF – Normal Status
System Reset	Press the LEFT or RIGHT key to reset the system. All OSD options will be reset to their original manufacturer settings

You can press the ENTER button to return to the OSD Main Menu or you can press the MENU button to exit the OSD entirely (in both cases, your changes will be saved).

## 4.4 Channel Submenu

The Channel submenu in the Main Menu allows you to configure **Contrast**, **Brightness** and **Saturation** for each Channel. You can use the UP or DOWN key to select and highlight a channel. Then press the FREEZE key to tab through the three option fields (Con, Bri, Sat). Once you have highlighted a field, you can use the LEFT or RIGHT keys to adjust the value. This Evaluation Board only displays configurations for 6 of the 9 channels (i.e. for demo purposes only).

CHANNEL			
CH	CON	BRI	SAT
Channel1	32	08	32
Channel2	32	08	32
Channel3	32	08	32
Channel4	32	08	32
Channel5	32	08	32
Channel6	32	08	32

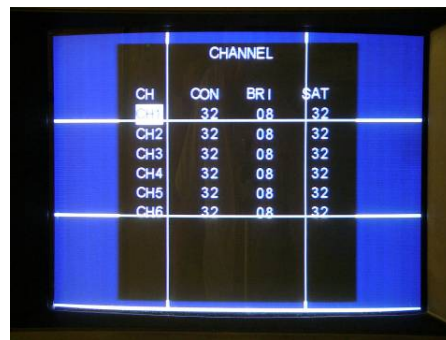

## 4.5 PIP Submenu

The PIP submenu allows you to configure the PIP (Picture-in-Picture) display mode. PIP mode is basically 4 smaller windows (each showing a camera image) that are overlaid on the default full screen camera display (configured in the POP submenu).

The PIP submenu is shown below. You can press the UP or DOWN key to select one of the four PIP windows. Then use the FREEZE key to tab through the option fields for that window.



PIP		
MODE	SW	CH
PIP 1	ON	1
PIP 2	ON	2
PIP 3	ON	3
PIP 4	ON	4



The option fields are explained below.

Option	Description
Mode	PIP1 – PIP4 represent the 4 windows available on the PIP display screen.
SW	This switch will either turn ON/OFF the display for that PIP window.
CH	Selects the camera to be displayed in the PIP window.

### 4.6 POP Submenu

POP display screen shows different camera video images displayed side-by-side in separate windows.

The available POP menus include:

- **9CH** - 9 channel
- **QUAD** - 4 channel
- **POP** - 2 channel
- **FULL** - Single channel



Once you are in the POP submenu (shown below), you can use the UP or DOWN keys to access one of the display modes (e.g. Quad). Then use the FREEZE key to tab through the different windows for that mode (e.g. Quad mode will have 4 windows). Then use the LEFT or RIGHT keys to select the camera to display in that window.

		POP							
MODE	WIN1	2	4	5	6	7	8	9	
9CH	1	2	4	5	6	7	8	9	
QUAD	1	2	3	4					
POP	1	2							
Full	1								



## 4.7 Auto Sequence Submenu

The Auto Sequence function allows you to automatically display video from different cameras in sequence, one after the other, in full screen mode. The Auto Sequence camera images to be displayed can be configured in this OSD menu item. Once you have entered the Auto Sequencing sub menu, use the UP/DOWN keys to select between the two configuration line items.

AUTO SEQUENCE	
AUTO SWITCH	1 2 3 4 F 6 7 8 F
SEQUENCE TIME	10 Sec.



Option	Description
Auto Switch	The nine option fields in this configuration item represent the nine cameras in order (1-9). Use the FREEZE key to tab through the 9 camera fields. If you want a particular camera image to be included in the Auto Sequence display mode, toggle the camera's option field from "F" to the camera number.
Sequence Time	This represents the time interval, during Auto Sequencing, before changing to the next camera in sequence. Use the LEFT or RIGHT keys to adjust the time interval.

## 4.8 Time Submenu

The Time Submenu allows you to set the date and time for the board. Use the UP/DOWN keys to toggle between **Date** and **Time**. Once you have highlighted the configuration line item (Date or Time), use the FREEZE key to tab through the different option fields (e.g. YY, MM or DD). Once you have highlighted a specific field, use the LEFT/RIGHT keys to adjust the field.

TIME	
DATE	08:02:20
TIME	12:05:48

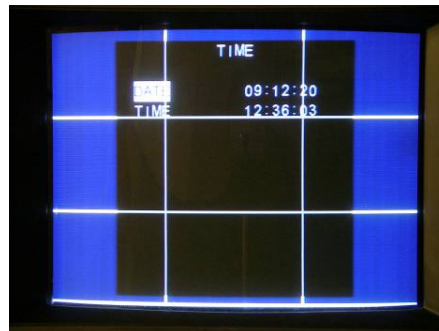

## 4.9 Alarm Submenu

This product is capable of detecting Video Loss and Motion. You can turn on/off these functions in this submenu.

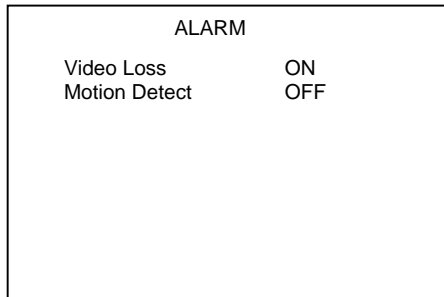

The options for this submenu are explained below:

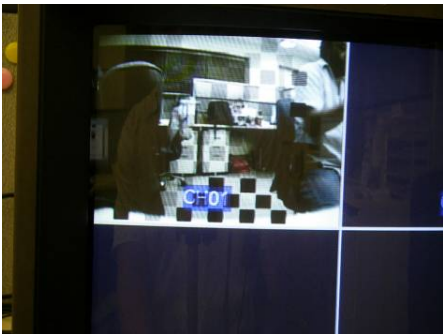
Option	Description
Video Loss	<p>When this option is turned ON, the product senses when there is loss of picture for any channel and then it will change the label for that camera on the monitor display from "CH0X" to "CHXL" (e.g. CH03 to CH3L).</p>  <p>The image shows a 4-camera monitor. The top-left camera (CH01) shows a desk with a plant. The top-right camera (CH02) shows a server rack. The bottom-left camera (CH3L) shows a desk with a plant. The bottom-right camera (CH4L) shows a server rack. The labels 'CH01', 'CH02', 'CH3L', and 'CH4L' are visible at the bottom of each camera's frame.</p>
Motion Detect Alarm	<p>This option turns on/off the Motion Detect function. Use the LEFT/RIGHT keys to turn this function on and off. When this option is turned on, motion can be detected in any of the cameras. Flashing square dots will show on all screens and become increasingly dense as it detects more movement.</p>  <p>The image shows a 4-camera monitor. The top-left camera (CH01) shows a person in a white shirt. The top-right camera (CH02) shows a person in a white shirt. The bottom-left camera (CH03) shows a person in a white shirt. The bottom-right camera (CH04) shows a person in a white shirt. The labels 'CH01', 'CH02', 'CH03', and 'CH04' are visible at the bottom of each camera's frame. Flashing square dots are visible on all screens.</p> <p>Note: This demo version will apply the dots on all screens, regardless of which camera video the motion was detected on.</p>

# 5 Remote Control

## 5.1 Remote Control Button Description

This product comes with a convenient Remote Control unit that allows you to control the AL37219 board without having to use the board's keypad. The Remote Control keypad is similar to the board keypad but with some functional differences.



Key	Function
Up Arrow	Serves as the "Up" navigation key on the OSD menus/submenus.
Down Arrow	Serves as the "Down" navigation key on the OSD menus/submenus.
Left Arrow	Serves to flip backwards through the available selections for an option.
Right Arrow	Serves to flip forward through the available selections for an option.
Select	Used to drill down to a submenu on the OSD menus or to tab through the different columns on a submenu line.
MENU	This key allows you to enter and exit the OSD menu
Freeze	Freezes the video images on all screens.
ZOOM	This key allows you to zoom-in on the video image in any display mode. The zoom scaling goes from x1 to x2 to x4 to x8 and then back to x1.
PIP	Displays 4 camera images onto 1 large camera image, which is the "FULL" camera selection in POP submenu.
Buttons 1-9	These 9 keys are associated with the 9 cameras that can be attached to this board. When you press one of these keys, the full screen video image from the associated camera will display.
FULL	Shows POP screen, which is the 2-Panel camera display.
FUNC	Shows 4-Panel (Quad) camera display
MODE	Shows 9-Panel camera display
Esc	Serves to move backward or move up from Submenu to Main Menu on the OSD screens

Note that all other buttons on the remote controller that were not mentioned are either disabled or not intended for use.

## **CONTACT INFORMATION**

AverLogic Technologies, Corp.  
E-Mail: [sales@averlogic.com](mailto:sales@averlogic.com)  
URL: <http://www.averlogic.com>