

Ordering number C11918_STRADA-T-6X1-DNW

Family	Strada-Module	FWHM	Asymmetric degrees
Type	Lens array	Efficiency	93 %
LED	3535 Ceramic (LEMWA33)	3W cd/lm	0.540
Color	Clear	Gerber File	Available
Diameter	119.8 x 25.2 mm		
Height	5.6 mm		
Style	Rectang		
Optic Material	PMMA		
Holder Material	-		
Fastening	Screw, pin, glue		
Status	Ready		

Ordering number C12449_STRADA-T-6X1-DWC

Family	Strada-Module	FWHM	Asym degrees
Type	Lens array	Efficiency	94 %
LED	3535 Ceramic (LEMWA33)	3W cd/lm	0.540
Color	Clear	Gerber File	Available
Diameter	119.8 x 25.2 mm		
Height	5.5 mm		
Style	Rectang		
Optic Material	PMMA		
Holder Material	-		
Fastening	Screw, pin, glue		
Status	Ready		

NOTE: The typical divergence will be changed by different color, chip size and chip position tolerance. The typical total divergence is the full angle measured where the luminous intensity is half of the peak value.



PRODUCT DATASHEET Strada-Module series

last update 2/1/2013

GENERAL INFORMATION

- Product series especially designed & optimized for 3535 Ceramic 3W (LEMWA33) series of LEDs.
- Special care taken to make light distribution as uniform as possible.
- Lens material optical grade PMMA with high UV and temperature resistance. Allows use of high current and temperature conditions.

Please find more information about used material from below:

http://ledil.fi/sites/default/files/Documents/Technical/Material/PMMA%20N%20UL94_Yellow%20Card.pdf

<http://ledil.fi/sites/default/files/Documents/Technical/Material/PMMA%20N%20PLEXIGLAS-Datasheet.pdf>

D C B A

4

4

LED in the center of the optic

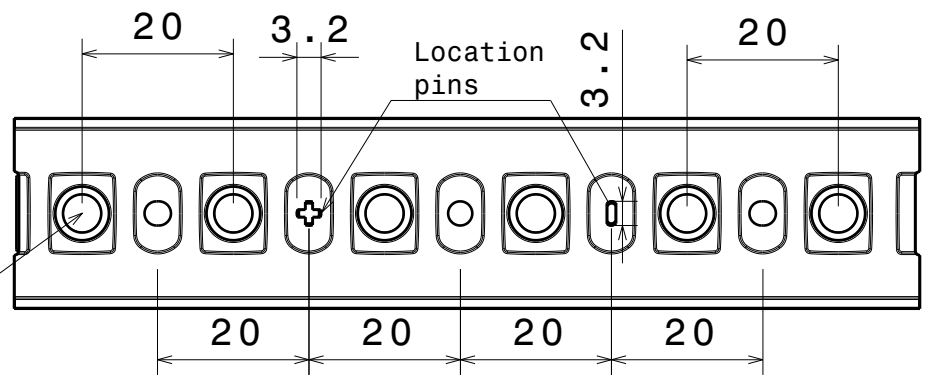

Bottom view

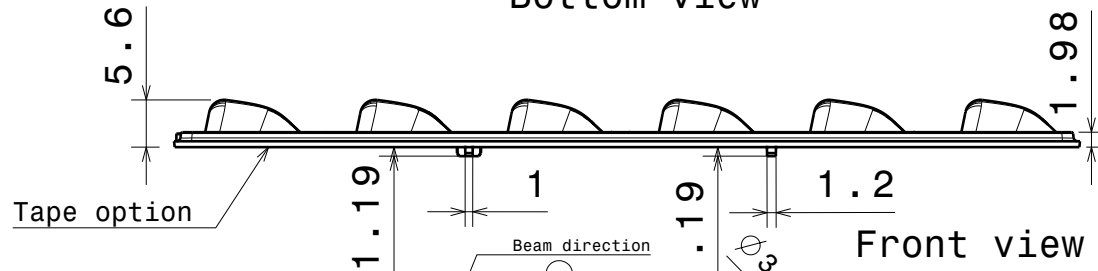

Front view

3

3

Note, Ledil Oy won't provide tape or sealing plates for this product.

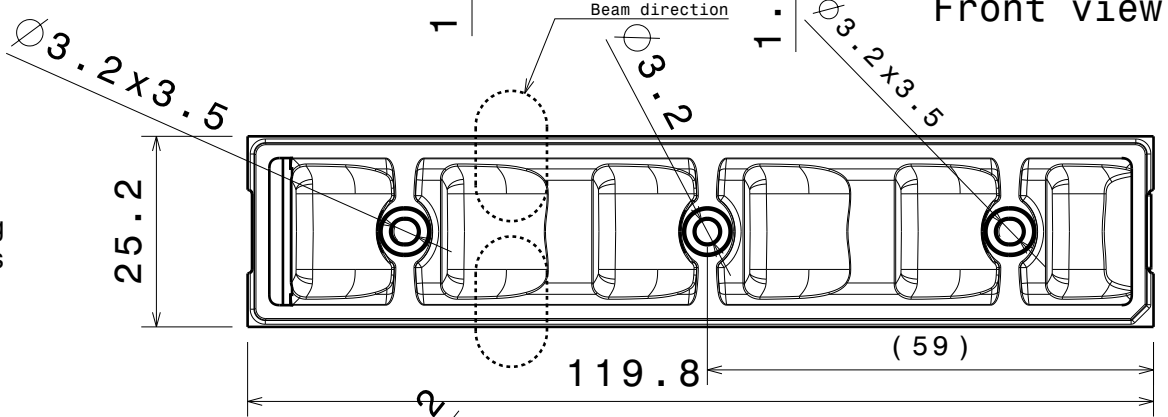

Layout fully compatible with individual Strada-series lenses

2

2

Materials:
Lens PMMA

Tolerances for dimensions:
0-20mm tolerance value $\pm 0.1\text{mm}$
21-45mm tolerance value $\pm 0.2\text{mm}$
46-90mm tolerance value $\pm 0.3\text{mm}$
91-100mm tolerance value $\pm 0.4\text{mm}$
101-mm tolerance value $\pm 0.5\text{mm}$

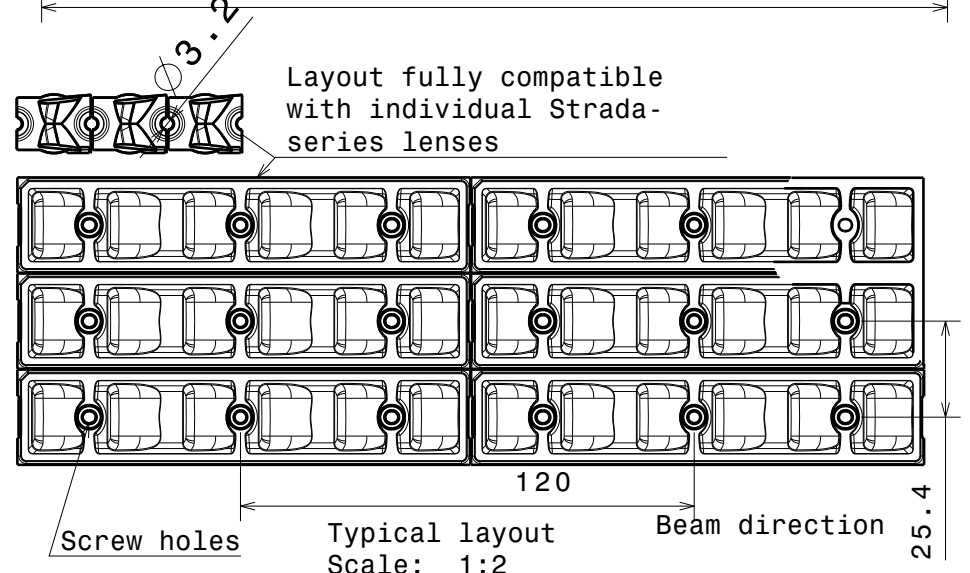

Typical layout
Scale: 1:2

This drawing is our property. It can't be reproduced or communicated without our written agreement.



Ledil Oy
Salorankatu 10
FIN-24100 SALO
Finland

1

1

DRAWN BY pv		DATE 1.11.2012		DRAWING TITLE Datasheet Strada-T-6x1-DNW Lens			
CHECKED BY jl		DATE 1.11.2012		SIZE A4	DRAWING NUMBER C11918		REV 6
DESIGNED BY hh		DATE 02.12.2010		SCALE 2:1	WEIGHT (g)	SHEET 1/1	

D A

Luminaire: LEDiL Oy C11918_Strada-T-6x1-DNW_(LG3535) Eff. 93,3%
Lamps: 1 x LG Ceramic 3535 PKG (571lm@250mA)

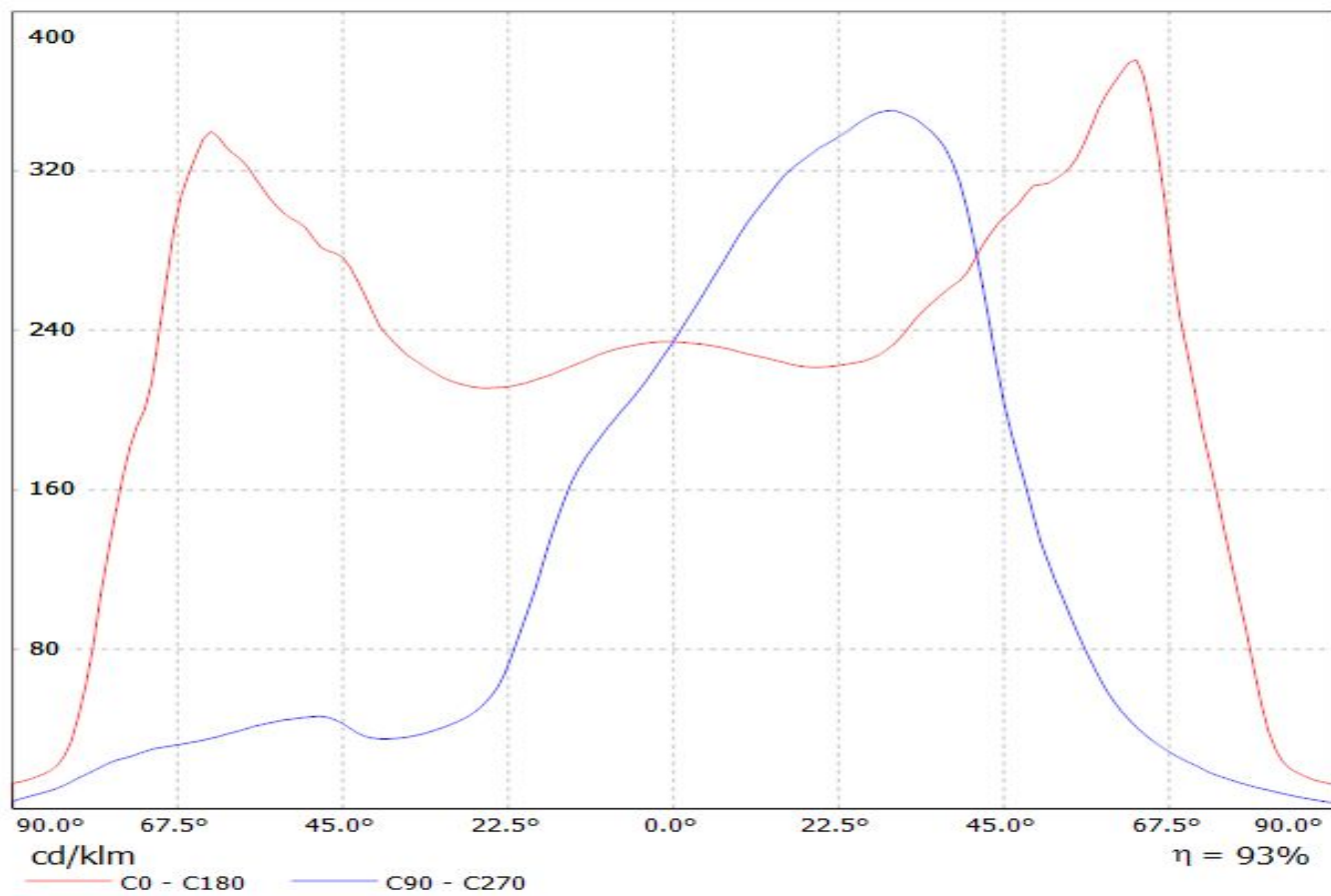

Luminaire: LEDiL Oy C12499_Strada-T-6x1-DWC_(LG3535) Eff. 93,7%
Lamps: 1 x LG Ceramic 3535 PKG (571lm@250mA)

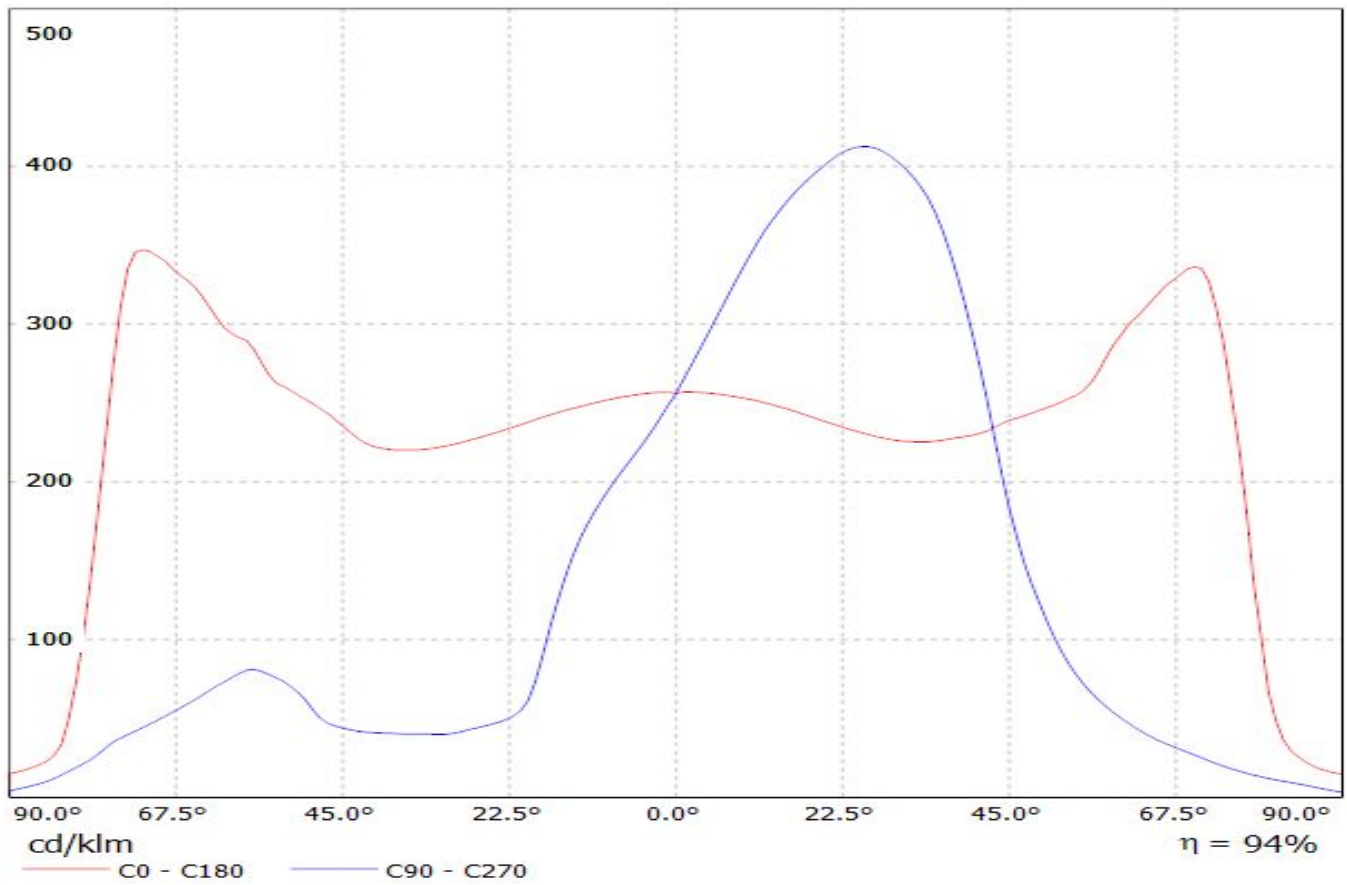

Luminaire: LEDiL Oy C11918_Strada-T-6x1-DNW_(LG3535) Eff. 93,3%
Lamps: 1 x LG Ceramic 3535 PKG (571lm@250mA)

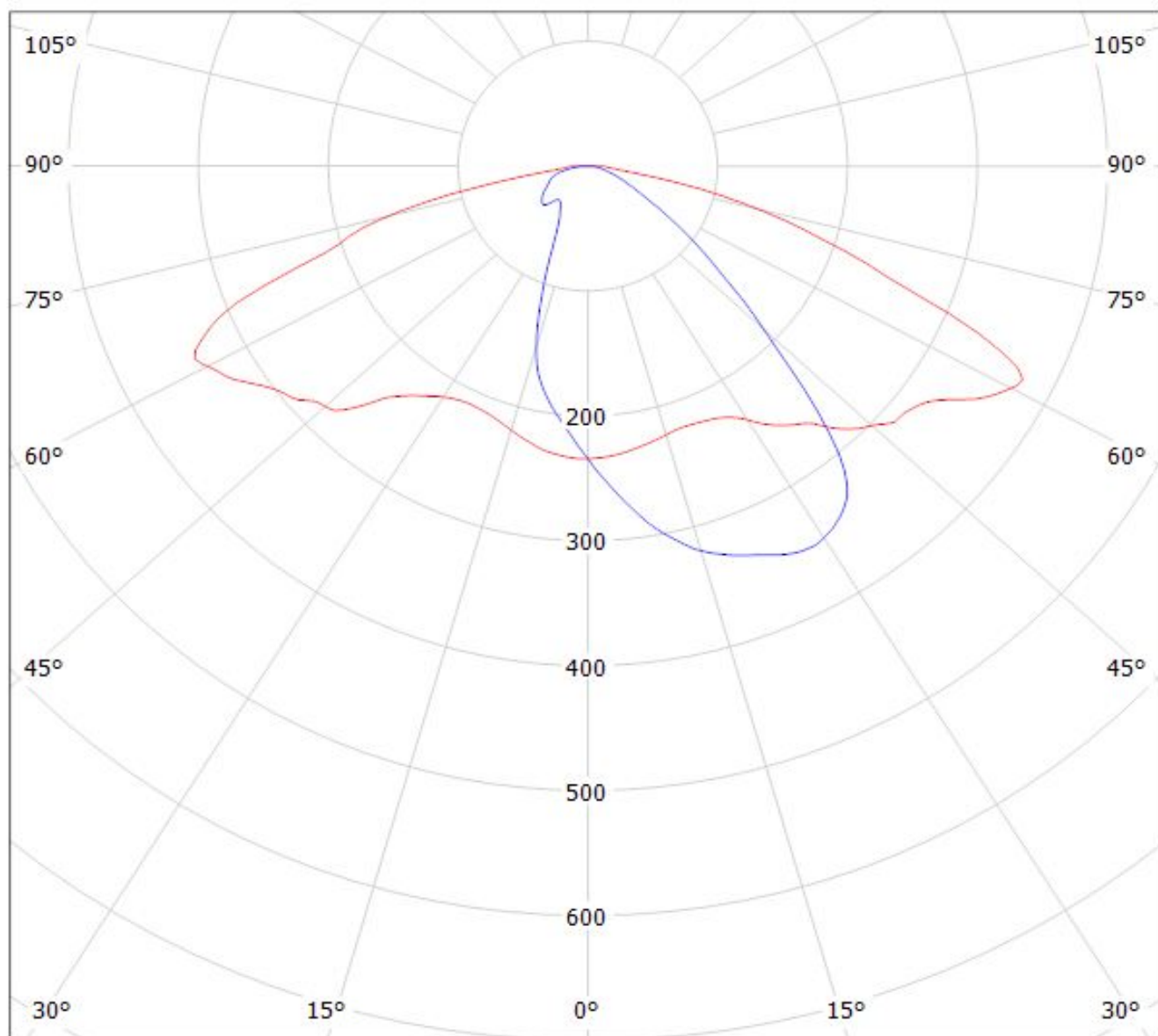

cd/klm

$\eta = 93\%$

— C0 - C180 — C90 - C270

Luminaire: LEDiL Oy C12499_Strada-T-6x1-DWC_(LG3535) Eff. 93,7%
Lamps: 1 x LG Ceramic 3535 PKG (571lm@250mA)

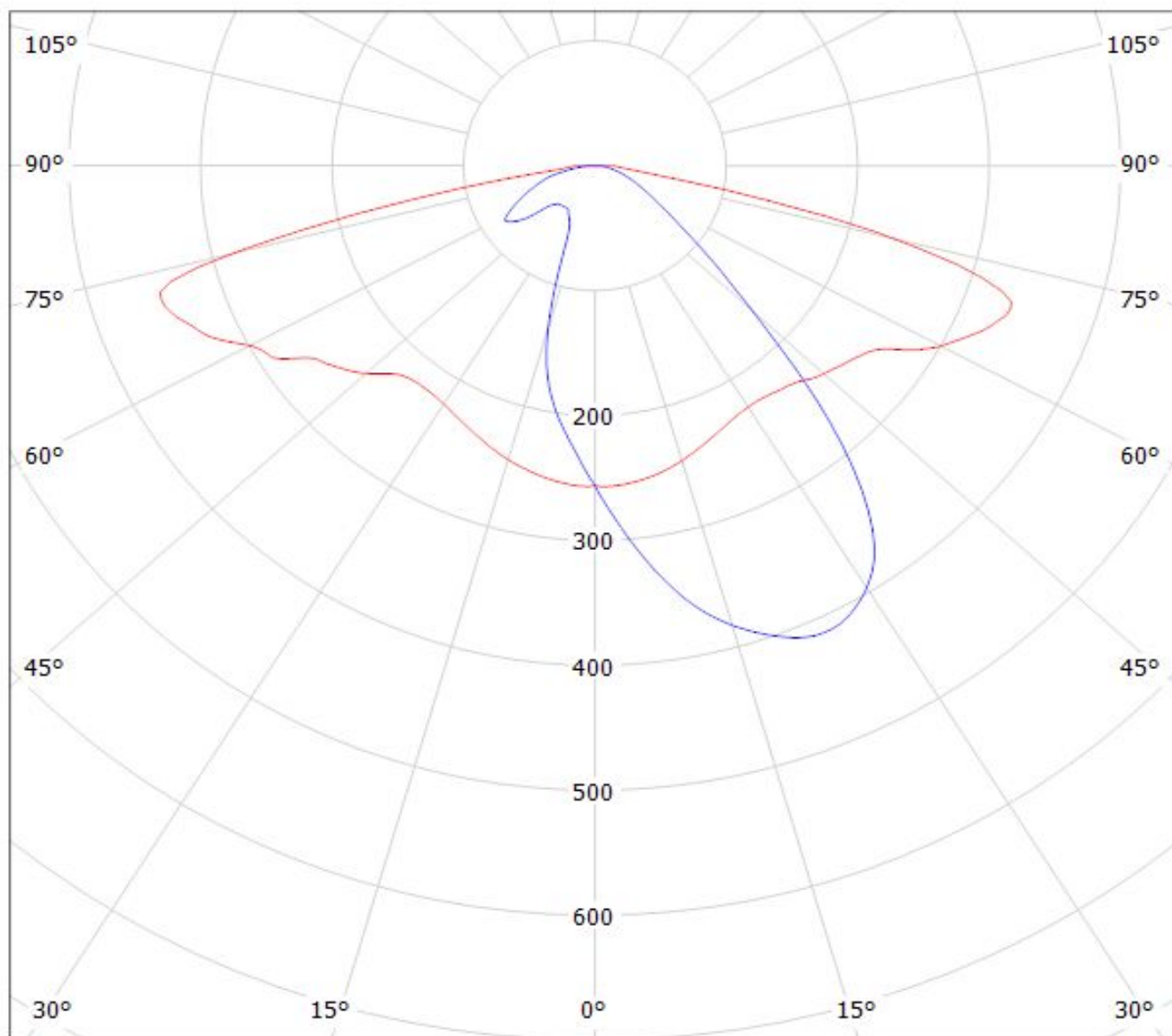

cd/klm

— C0 - C180

— C90 - C270

$\eta = 94\%$