

### Description

The 74LVC1G126 is a single non-inverting buffer/bus driver with a 3-state output. The output enters a high impedance state when a LOW-level is applied to the output enable (OE) pin. The device is designed for operation with a power supply range of 1.65V to 5.5V. The inputs are tolerant to 5.5V allowing this device to be used in a mixed voltage environment. The device is fully specified for partial power down applications using I<sub>OFF</sub>. The I<sub>OFF</sub> circuitry disables the output preventing damaging current backflow when the device is powered down.

### Features

- Wide Supply Voltage Range from 1.65 to 5.5V
- ± 24mA Output Drive at 3.3V
- CMOS low power consumption
- I<sub>OFF</sub> Supports Partial-Power-Down Mode Operation
- Inputs accept up to 5.5V
- ESD Protection Tested per JESD 22
  - Exceeds 200-V Machine Model (A115-A)
  - Exceeds 2000-V Human Body Model (A114-A)
  - Exceeds 1000-V Charged Device Model (C101C)
- Latch-Up Exceeds 100mA per JESD 78, Class II
- Range of Package Options
- Direct Interface with TTL Levels Levels
- All packages Assembled with “Green” Molding Compound (no Br, Sb)
- Lead Free Finish/ RoHS Compliant (Note 1)

### Pin Assignments

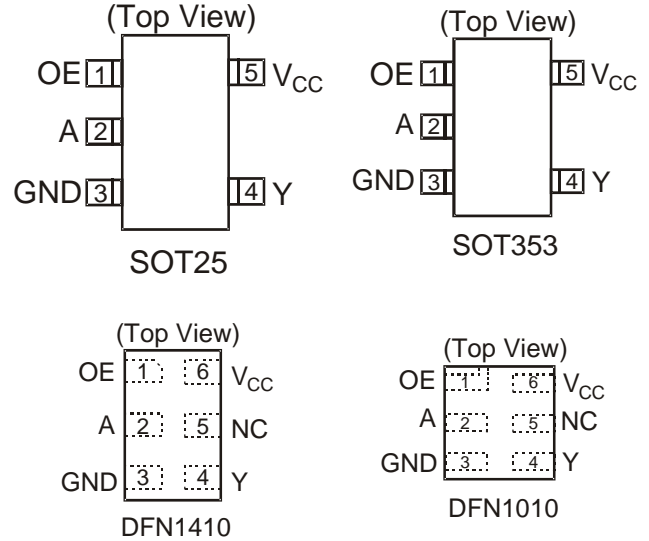

### Applications

- Voltage Level Shifting
- Bus Driver / Repeater
- Power Down Signal Isolation
- General Purpose Logic
- Wide array of products such as:
  - PCs, networking, notebooks, netbooks, PDAs
  - Tablet Computers, E-readers
  - Computer peripherals, hard drives, CD/DVD ROM
  - TV, DVD, DVR, set top box
  - Cell Phones, Personal Navigation / GPS
  - MP3 players ,Cameras, Video Recorders

Notes: 1. EU Directive 2002/95/EC (RoHS). All applicable RoHS exemptions applied. Please visit our website at [http://www.diodes.com/products/lead\\_free.html](http://www.diodes.com/products/lead_free.html)

**Pin Descriptions**

Pin Name	Description
OE	Output Enable
A	Data Input
GND	Ground
Y	Data Output
V <sub>CC</sub>	Supply Voltage
NC	No Connection

**Logic Diagram**

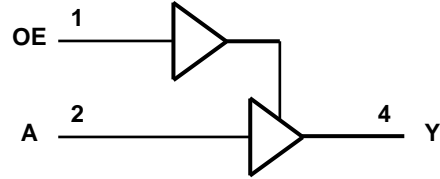

**Function Table**

Inputs		Output
OE	A	Y
H	H	H
H	L	L
L	X	Z

**Absolute Maximum Ratings (Note 2)**

Symbol	Description	Rating	Unit
ESD HBM	Human Body Model ESD Protection	2	KV
ESD CDM	Charged Device Model ESD Protection	1	KV
ESD MM	Machine Model ESD Protection	200	V
V <sub>CC</sub>	Supply Voltage Range	-0.5 to 6.5	V
V <sub>I</sub>	Input Voltage Range	-0.5 to 6.5	V
V <sub>O</sub>	Voltage applied to output in high impedance or I <sub>OFF</sub> state	-0.5 to 6.5	V
V <sub>O</sub>	Voltage applied to output in high or low state	-0.3 to V <sub>CC</sub> +0.5	V
I <sub>IK</sub>	Input Clamp Current V <sub>I</sub> <0	-50	mA
I <sub>OK</sub>	Output Clamp Current	-50	mA
I <sub>O</sub>	Continuous output current	±50	mA
	Continuous current through V <sub>DD</sub> or GND	±100	mA
T <sub>J</sub>	Operating Junction Temperature	-40 to 150	°C
T <sub>STG</sub>	Storage Temperature	-65 to 150	°C

Notes: 2. Stresses beyond the absolute maximum may result in immediate failure or reduced reliability. These are stress values and device operation should be within recommend values.

### Recommended Operating Conditions (Note 3)

Symbol	Parameter	Min	Max	Unit	
V <sub>CC</sub>	Operating Voltage	Operating	1.65	5.5	V
		Data retention only	1.5	15	V
V <sub>IH</sub>	High-level Input Voltage	V <sub>CC</sub> = 1.65V to 1.95V	0.65 X V <sub>CC</sub>		V
		V <sub>CC</sub> = 2.3V to 2.7V	1.7		
		V <sub>CC</sub> = 3V to 3.6V	2		
		V <sub>CC</sub> = 4.5V to 5.5V	0.7 X V <sub>CC</sub>		
V <sub>IL</sub>	Low-level input voltage	V <sub>CC</sub> = 1.65V to 1.95V		0.35 X V <sub>CC</sub>	V
		V <sub>CC</sub> = 2.3V to 2.7V		0.7	
		V <sub>CC</sub> = 3V to 3.6V		0.8	
		V <sub>CC</sub> = 4.5V to 5.5V		0.3 X V <sub>CC</sub>	
V <sub>I</sub>	Input Voltage	0	5.5	V	
V <sub>O</sub>	Output Voltage	0	V <sub>CC</sub>	V	
I <sub>OH</sub>	High-level output current	V <sub>CC</sub> = 1.65V		-4	mA
		V <sub>CC</sub> = 2.3V		-8	
		V <sub>CC</sub> = 3V		-16	
		V <sub>CC</sub> = 4.5V		-24	
I <sub>OL</sub>	Low-level output current	V <sub>CC</sub> = 1.65V		4	mA
		V <sub>CC</sub> = 2.3V		8	
		V <sub>CC</sub> = 3V		16	
		V <sub>CC</sub> = 4.5V		24	
Δt/ΔV	Input transition rise or fall rate	V <sub>CC</sub> = 1.8V ± 0.15V, 2.5V ± 0.2V		20	ns/V
		V <sub>CC</sub> = 3.3V ± 0.3V		10	
		V <sub>CC</sub> = 5V ± 0.5V		5	
T <sub>A</sub>	Operating free-air temperature	-40	125	°C	

Notes: 3. Unused inputs should be held at V<sub>CC</sub> or Ground.

### Electrical Characteristics (All typical values are at $V_{CC} = 3.3V$ , $T_A = 25^\circ C$ )

Symbol	Parameter	Test Conditions	$V_{CC}$	-40°C to 85°C			-40°C to 125°C		Unit
				Min	Typ.	Max	Min	Max	
$V_{OH}$	High Level Output Voltage	$I_{OH} = -100\mu A$	1.65V to 5.5V	$V_{CC} - 0.1$			$V_{CC} - 0.1$		V
		$I_{OH} = -4mA$	1.65V	1.2		0.95			
		$I_{OH} = -8mA$	2.3V	1.9		1.7			
		$I_{OH} = -16mA$	3V	2.4		2.2			
		$I_{OH} = -24mA$		2.3		2.0			
		$I_{OH} = -32mA$	4.5V	3.8		3.4			
$V_{OL}$	Low Level Output Voltage	$I_{OL} = 100\mu A$	1.65V to 5.5V			0.1		0.1	V
		$I_{OL} = 4mA$	1.65V			0.45		0.7	
		$I_{OL} = 8mA$	2.3V			0.3		0.45	
		$I_{OL} = 16mA$	3V			0.4		0.6	
		$I_{OL} = 24mA$				0.55		0.8	
		$I_{OL} = 32mA$	4.5V			0.55		.8	
$I_I$	Input Current	$V_I = 5.5V$ or GND	0 to 5.5V		$\pm 0.1$	$\pm 5$		$\pm 100$	$\mu A$
$I_{OFF}$	Power Down Leakage Current	$V_I$ or $V_O = 5.5V$	0V			$\pm 10$		$\pm 200$	$\mu A$
$I_{OZ}$	Z State Leakage Current	$V_O = 0$ to 5.5V	3.6V		0.1	10		20	$\mu A$
$I_{CC}$	Supply Current	$V_I = 5.5V$ or GND $I_O = 0$	5.5V		0.1	10		200	$\mu A$
$\Delta I_{CC}$	Additional Supply Current	One input at $V_{CC} - 0.6V$ Other inputs at $V_{CC}$ or GND	3V to 5.5V			500		5000	$\mu A$
$C_i$	Input Capacitance	$V_i = V_{CC}$ or GND	3.3V		5				pF

### Operating Characteristics

$T_A = 25^\circ C$

Parameter			Test Conditions	$V_{CC} = 1.8V$	$V_{CC} = 2.5V$	$V_{CC} = 3.3V$	$V_{CC} = 5V$	Unit
				Typ.	Typ.	Typ.	Typ.	
$C_{pd}$	Power dissipation capacitance	Outputs enabled	f = 10 MHz	19	19	19	21	pF
		Outputs disabled		2	2	3	4	

### Package Characteristics (All typical values are at $V_{CC} = 3.3V$ , $T_A = 25^\circ C$ )

Symbol	Parameter	Test Conditions	$V_{CC}$	Min	Typ.	Max	Unit
$\theta_{JA}$	Thermal Resistance Junction-to-Ambient	SOT25	(Note 4)		204		$^\circ C/W$
		SOT353			371		
		DFN1010			445		
		DFN1410			460		
$\theta_{JC}$	Thermal Resistance Junction-to-Case	SOT25	(Note 4)		52		$^\circ C/W$
		SOT35			143		
		DFN1010			250		
		DFN1410			265		

Notes: 4. Test condition for SOT25, SOT353, DFN1410 and DFN1010: Device mounted on FR-4 substrate PC board, 2oz copper, with minimum recommended pad layout.

### Switching Characteristics

Figure 1 Typical Values at  $T_A = 25^\circ C$  and nominal voltages 1.8 V, 2.5 V, 2.7 V, 3.3 V, and 5.0V.

Parameter	From Input	To Output	$V_{CC}$	$T_A = -40^\circ C$ to $85^\circ C$			$T_A = -40^\circ C$ to $125^\circ C$		Unit
				Min	Typ.	Max	Min	Max	
$t_{pd}$	A	Y	$1.8V \pm 0.15V$	1.0	3.0	8.0	1.0	10.5	ns
			$2.5V \pm 0.2V$	0.5	2.1	5.5	0.5	7.0	
			2.7V	0.5	2.3	5.5	0.5	7.5	
			$3.3V \pm 0.3V$	0.5	2.0	4.5	0.5	6.0	
			$5.0V \pm 0.5V$	0.5	1.7	4.0	0.5	5.5	
$t_{en}$	OE	Y	$1.8V \pm 0.15V$	1.0	3.2	9.4	1.0	12.0	ns
			$2.5V \pm 0.2V$	0.5	2.2	6.6	0.5	8.5	
			2.7V	0.5	2.4	6.6	0.5	8.5	
			$3.3V \pm 0.3V$	0.5	2.1	5.3	0.5	7.0	
			$5.0V \pm 0.5V$	0.5	1.6	5.0	0.5	6.5	
$t_{dis}$	OE	Y	$1.8V \pm 0.15V$	1.0	4.3	9.2	1.0	12.0	ns
			$2.5V \pm 0.2V$	0.5	2.7	5.5	0.5	7.0	
			2.7V	0.5	3.4	5.5	0.5	7.0	
			$3.3V \pm 0.3V$	0.5	3.0	5.5	0.5	7.0	
			$5.0V \pm 0.5V$	0.5	2.2	4.2	0.5	5.5	

**Parameter Measurement Information**

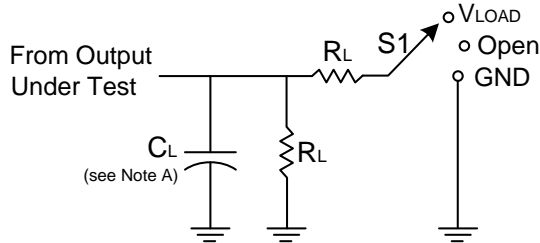

TEST	S1
$t_{PLH}/t_{PHL}$	Open
$t_{PLZ}/t_{PZL}$	$V_{LOAD}$
$t_{PHZ}/t_{PZH}$	GND

$V_{CC}$	Inputs		$V_M$	$V_{LOAD}$	$C_L$	$R_L$	$V_{\Delta}$
	$V_I$	$t_r/t_f$					
$1.8V \pm 0.15V$	$V_{CC}$	$\leq 2ns$	$V_{CC}/2$	$2 \times V_{CC}$	30pF	1K $\Omega$	0.15V
$2.5V \pm 0.2V$	$V_{CC}$	$\leq 2ns$	$V_{CC}/2$	$2 \times V_{CC}$	30pF	500 $\Omega$	0.15V
2.7V	2.7V	$\leq 2.5ns$	1.5V	6V	50pF	500 $\Omega$	0.3V
$3.3V \pm 0.3V$	3V	$\leq 2.5ns$	1.5V	6V	50pF	500 $\Omega$	0.3V
$5V \pm 0.5V$	$V_{CC}$	$\leq 2.5ns$	$V_{CC}/2$	$2 \times V_{CC}$	50pF	500 $\Omega$	0.3V

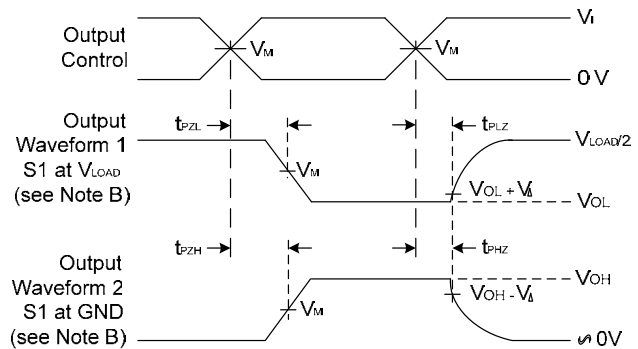
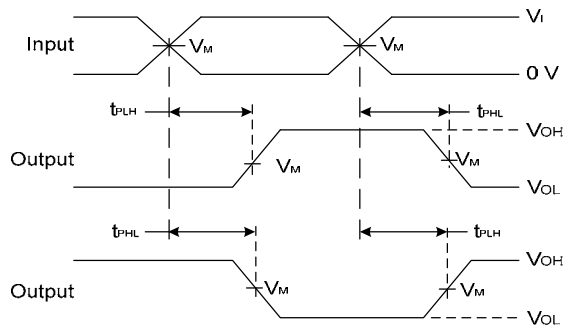
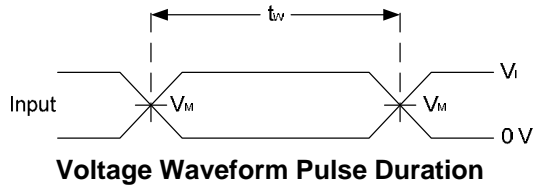
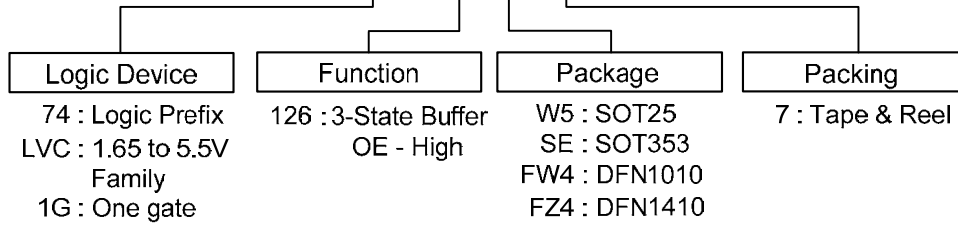

**Figure 1. Load Circuit and Voltage Waveforms**

- Notes:
- A. Includes test lead and test apparatus capacitance.
  - B. All pulses are supplied at pulse repetition rate  $\leq 10$  MHz.
  - C. Inputs are measured separately one transition per measurement.
  - D.  $t_{PLZ}$  and  $t_{PHZ}$  are the same as  $t_{dis}$ .
  - E.  $t_{PZL}$  and  $t_{PZH}$  are the same as  $t_{EN}$ .
  - F.  $t_{PLH}$  and  $t_{PHL}$  are the same as  $t_{PD}$ .

### Ordering Information

#### 74LVC1G 126XXX - 7



Device	Package Code	Packaging (Note 6)	7" Tape and Reel	
			Quantity	Part Number Suffix
74LVC1G126W5-7	W5	SOT25	3000/Tape & Reel	-7
74LVC1G126SE-7	SE	SOT353	3000/Tape & Reel	-7
74LVC1G126FW4-7	FW4	DFN1010	5000/Tape & Reel	-7
74LVC1G126FZ4-7	FZ4	DFN1410	5000/Tape & Reel	-7

Notes: 5. Pad layout as shown on Diodes Inc. suggested pad layout document AP02001, which can be found on our website at <http://www.diodes.com/datasheets/ap02001.pdf>  
 6. The taping orientation is located on our website at <http://www.diodes.com/datasheets/ap02007.pdf>

### Marking Information

#### (1) SOT25 and SOT353

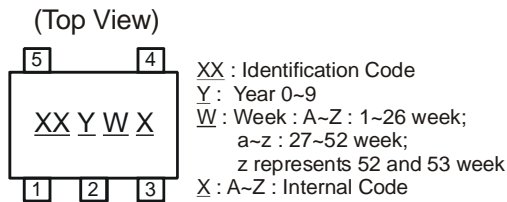

Part Number	Package	Identification Code
74LVC1G126W5	SOT25	UZ
74LVC1G126SE	SOT353	UZ

#### (3) DFN1010 and DFN1410

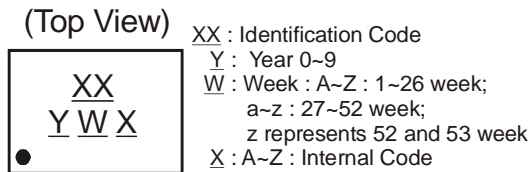

Part Number	Package	Identification Code
74LVC1G126FW4	DFN1010	UZ
74LVC1G126FZ4	DFN1410	UZ

**Package Outline Dimensions (All Dimensions in mm)**

**(1) Package Type: SOT25**

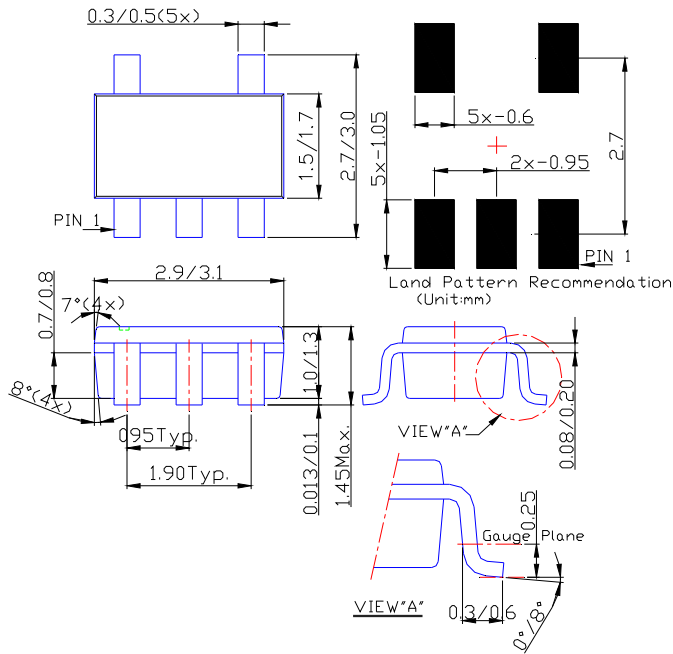

**(2) Package Type: SOT353**

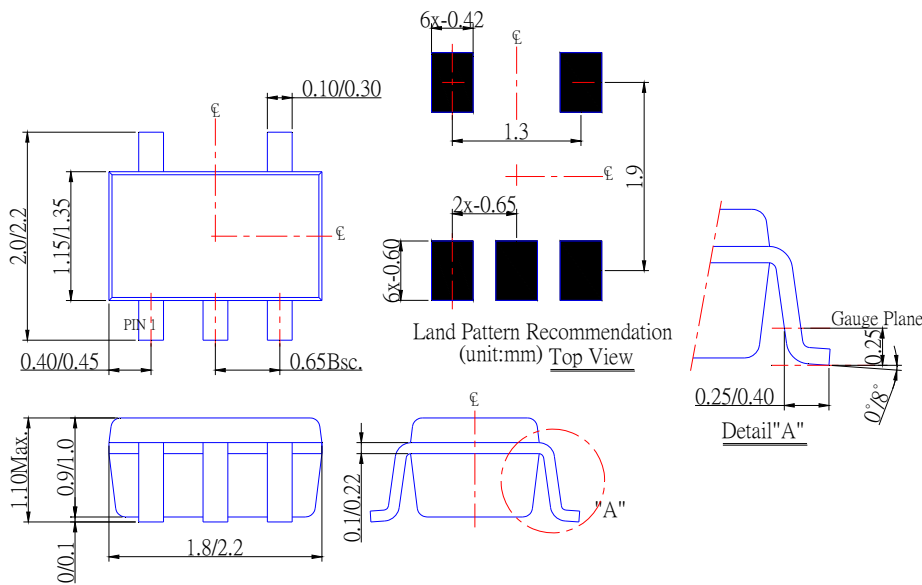



**IMPORTANT NOTICE**

DIODES INCORPORATED MAKES NO WARRANTY OF ANY KIND, EXPRESS OR IMPLIED, WITH REGARDS TO THIS DOCUMENT, INCLUDING, BUT NOT LIMITED TO, THE IMPLIED WARRANTIES OF MERCHANTABILITY AND FITNESS FOR A PARTICULAR PURPOSE (AND THEIR EQUIVALENTS UNDER THE LAWS OF ANY JURISDICTION).

Diodes Incorporated and its subsidiaries reserve the right to make modifications, enhancements, improvements, corrections or other changes without further notice to this document and any product described herein. Diodes Incorporated does not assume any liability arising out of the application or use of this document or any product described herein; neither does Diodes Incorporated convey any license under its patent or trademark rights, nor the rights of others. Any Customer or user of this document or products described herein in such applications shall assume all risks of such use and will agree to hold Diodes Incorporated and all the companies whose products are represented on Diodes Incorporated website, harmless against all damages.

Diodes Incorporated does not warrant or accept any liability whatsoever in respect of any products purchased through unauthorized sales channel.

Should Customers purchase or use Diodes Incorporated products for any unintended or unauthorized application, Customers shall indemnify and hold Diodes Incorporated and its representatives harmless against all claims, damages, expenses, and attorney fees arising out of, directly or indirectly, any claim of personal injury or death associated with such unintended or unauthorized application.

Products described herein may be covered by one or more United States, international or foreign patents pending. Product names and markings noted herein may also be covered by one or more United States, international or foreign trademarks.

**LIFE SUPPORT**

Diodes Incorporated products are specifically not authorized for use as critical components in life support devices or systems without the express written approval of the Chief Executive Officer of Diodes Incorporated. As used herein:

A. Life support devices or systems are devices or systems which:

1. are intended to implant into the body, or
2. support or sustain life and whose failure to perform when properly used in accordance with instructions for use provided in the labeling can be reasonably expected to result in significant injury to the user.

B. A critical component is any component in a life support device or system whose failure to perform can be reasonably expected to cause the failure of the life support device or to affect its safety or effectiveness.

Customers represent that they have all necessary expertise in the safety and regulatory ramifications of their life support devices or systems, and acknowledge and agree that they are solely responsible for all legal, regulatory and safety-related requirements concerning their products and any use of Diodes Incorporated products in such safety-critical, life support devices or systems, notwithstanding any devices- or systems-related information or support that may be provided by Diodes Incorporated. Further, Customers must fully indemnify Diodes Incorporated and its representatives against any damages arising out of the use of Diodes Incorporated products in such safety-critical, life support devices or systems.

Copyright © 2011, Diodes Incorporated

[www.diodes.com](http://www.diodes.com)