

ScreenMaster RVG200 Paperless recorder

Measurement made easy



Introduction

This manual provides installation and operating procedures for the ScreenMaster RVG200 paperless recorder.

The ScreenMaster RVG200 provides secure and flexible process recording for up to 24 recording channels. Data recording is simple and reliable while meeting the electronic data security requirements of 21 CFR part 11.

USB connections simplify operation and operator interaction by enabling the use of peripheral equipment such as a keyboard, mouse or barcode scanner.

Ethernet communications enable easy integration to an existing network and the inbuilt FTP and web server functionality enable automatic process data collection from remote stations.

For more information

Further publications for the ScreenMaster RVG200 paperless recorder are available for free download from: www.abb.com

See links and reference numbers below or scan this code:



search for or click on:

Commissioning instructions

CI/RVG200-EN

Datasheet

DS/RVG200-EN

The Company

We are an established world force in the design and manufacture of instrumentation for industrial process control, flow measurement, gas and liquid analysis and environmental applications.

As a part of ABB, a world leader in process automation technology, we offer customers application expertise, service and support worldwide.

We are committed to teamwork, high quality manufacturing, advanced technology and unrivalled service and support.

The quality, accuracy and performance of the Company's products result from over 100 years experience, combined with a continuous program of innovative design and development to incorporate the latest technology.

Contents

1	Health & Safety	5
1.1	Safety precautions	5
1.2	Potential electrical safety hazards	5
1.3	Safety standards	5
1.4	Safety conventions	5
1.5	EC Directive 89/336/EEC	6
1.6	End-of-life disposal	6
1.7	Cleaning	6
1.8	Symbols	6
1.9	Restriction of Hazardous Substances (RoHS)	7
2	Functional overview	8
3	Installation	10
3.1	Siting	10
3.2	Mounting	12
3.3	Electrical connections	14
3.3.1	Accessing the recorder's connection terminals	15
3.3.2	Analog input / relay / hybrid connections	16
3.4	Analog / digital input module	18
3.4.1	Thermocouple	18
3.4.2	Resistance thermometer (RTD)	18
3.5	Power supply connections	19
3.6	2-lead temperature transmitter connections	20
3.7	Relays	21
3.8	MODBUS module	21
3.8.1	Host computer serial communications	21
3.8.2	2- or 4-wire connection	21
3.8.3	Pull-up and pull-down resistors	23
3.8.4	Termination resistor	23
3.8.5	Serial Connections	23

4	Operation	24
4.1	Powering up the recorder	24
4.2	Front panel features	24
4.3	Navigating views and groups	25
4.4	Operator menu overview	26
4.4.1	Navigating menus	27
4.5	Operator views	28
4.5.1	Chart view	28
4.5.2	Indicator view	31
4.5.3	Bargraph view	32
4.5.4	Overview display	33
4.6	Log views	34
4.6.1	Alarm event log	34
4.6.2	Totalizer log	35
4.6.3	Audit log	36
4.7	Operator menu system	37
4.8	Electronic signatures	48
5	Logging	49
5.1	Logging access	49
5.1.1	Password entry	51
5.2	Logging menu	52
6	Archiving	54
6.1	Introduction	54
6.2	Sample rates	55
6.3	Archive file types	55
6.4	Archive filenames	56
6.5	Channel data file creation	56
6.6	Log file creation	56
6.7	Data file examples	57
6.8	Data verification and integrity	57
6.9	Logging online / offline	58
6.10	Backing-up archived data	58
6.11	Archive wrap	58

7	Configuration	59
7.1	Introduction	59
7.2	Configuration level security	59
7.3	Configuration level access	60
7.4	Overview of configuration	63
7.5	Making changes to parameters	64
7.6	Exiting the configuration level	66
7.7	Common configuration	68
7.7.1	Setup	68
7.7.2	Archiving	70
7.7.3	Screen	71
7.7.4	Date and time	72
7.7.5	Security	74
7.7.6	Users	76
7.7.7	Operator messages	79
7.8	Process group configuration	80
7.8.1	Setting the recording parameters	80
7.8.2	Configuring the chart view	82
7.8.3	Configuring the indicator view	84
7.8.4	Configuring the bargraph view	85
7.8.5	Batch recording	85
7.9	Channel configuration	86
7.9.1	Recording channel setup	86
7.9.2	Analog input configuration	90
7.9.3	Digital input configuration	94
7.9.4	Alarm configuration	95
7.9.5	Totalizer configuration	102
7.9.6	Fo (sterilization optimization) configuration	108
7.10	I/O module configuration	112
7.10.1	Analog inputs	112
7.10.2	Relay modules	114
7.10.3	Hybrid modules	115
7.10.4	Ethernet module	117
7.10.5	Email	119
7.10.6	MODBUS TCP	121
7.10.7	Slave authorization	123
7.10.8	Comms analog input	124
7.10.9	Comms digital input	125
7.10.10	RS485 (MODBUS) communications	126
7.11	Functions	127
7.11.1	Custom linearizers	127
7.11.2	Real-time alarms	128
7.12	Logic editor	129
7.13	Math equations	130
7.13.1	Math functions	132
7.13.2	Using the math pad	133
7.13.3	Relative humidity calculation	134
7.13.4	Math block configuration	136

8	Specification	137
Appendix A	– Signal sources	146
Appendix B	– MODBUS TCP / MODBUS 485	149
B.1	Introduction	149
B.2	MODBUS commands supported	149
B.3	MODBUS exception responses	150
B.4	Operating mode MODBUS coils	151
B.5	Operating mode MODBUS registers	160
B.6	Communications – analog and digital inputs	164
Appendix C	– Storage capacity	170
C.1	Internal storage capacity – 256 MB flash memory	170
C.2	Internal storage capacity – 2 GB flash memory	170
C.3	External storage capacity	170
Appendix D	– Units	171
Appendix E	– Batch recording	173
E.1	Introduction	173
E.2	Operation	174
E.2.1	Overview	174
E.2.2	Starting a batch manually	174
E.2.3	Stopping a batch manually	176
E.2.4	Historical review	176
E.3	Configuration	177
E.3.1	Enabling batch security	177
E.3.2	Configuring batch access privileges	177
E.3.3	Batch configuration	178
Appendix F	– Character entry	180
Index		181
Acknowledgements and trademarks		186

1 Health & Safety

1.1 Safety precautions

Be sure to read, understand and follow the instructions contained within this manual before and during use of the equipment. Failure to do so could result in bodily harm or damage to the equipment.

Warning. Installation and maintenance of this product must only be conducted by personnel authorized to work on electrical installations and in accordance with relevant local regulations.

1.2 Potential electrical safety hazards

Warning. To ensure safe use when operating this equipment, the following points must be observed:

- Up to 240 V AC may be present. Be sure to isolate the supply before removing the terminal cover.
- Normal safety precautions must be taken to avoid the possibility of an accident occurring when operating in conditions of high pressure and / or temperature.

Safety advice concerning the use of the equipment described in this manual or any relevant Material Safety Data Sheets (where applicable) may be obtained from the Company, together with servicing and spares information.

1.3 Safety standards

This product has been designed to satisfy the requirements of IEC61010-1:2010 3rd edition 'Safety Requirements for Electrical Equipment for Measurement, Control and Laboratory Use'.

1.4 Safety conventions

Warning. In this manual, a warning is used to indicate a condition which, if not met, could cause serious personal injury and / or death. Do not proceed beyond a warning until all conditions have been met.

Caution. A caution is used to indicate a condition which, if not met, could cause minor or moderate personal injury and / or damage to the equipment. Do not proceed beyond a caution until all conditions have been met.

Note. A note is used to indicate important information or instructions that should be considered before operating the equipment.

1.5 EC Directive 89/336/EEC

Electrical – In order to meet the requirements of the EC Directive 89/336/EEC for EMC regulations, this product must not be used in a non-industrial environment.

1.6 End-of-life disposal







	<p>The recorder contains a small lithium battery that must be removed and disposed of responsibly in accordance with local environmental regulations.</p> <p>The remainder of the recorder does not contain any substance that causes undue harm to the environment and must be disposed of in accordance with the Directive on Waste Electrical and Electronic Equipment (WEEE). It must not be disposed of in Municipal Waste Collection.</p>
--	---

1.7 Cleaning

The complete recorder can be hosed down if it has been installed to IP66 / NEMA 4X standards – see Section 3.1, page 10. Warm water and a mild detergent can be used.

1.8 Symbols

Symbols that appear on this product are shown below:

	<p>Functional earth (ground) terminal.</p>
	<p>Alternating current supply only.</p>
	<p>Direct current supply only.</p>
	<p>This symbol, when noted on a product, indicates a potential hazard which could cause serious personal injury and / or death.</p> <p>The user should reference this instruction manual for operation and / or safety information.</p>
	<p>This symbol, when noted on a product enclosure or barrier, indicates that a risk of electrical shock and / or electrocution exists and indicates that only individuals qualified to work with hazardous voltages should open the enclosure or remove the barrier.</p>
	<p>The equipment is protected through double insulation.</p>
	<p>Recycle separately from general waste under the WEEE directive</p>

1.9 Restriction of Hazardous Substances (RoHS)



The European Union RoHS Directive and subsequent regulations introduced in member states and other countries limits the use of six hazardous substances used in the manufacturing of electrical and electronic equipment. Currently, monitoring and control monitors do not fall within the scope of the RoHS Directive, however ABB has taken the decision to adopt the recommendations in the Directive as the target for all future product design and component purchasing.

2 Functional overview

The recorder features the following functionality:

- A touchscreen featuring swipe gesture control providing fast and intuitive operation.
- 24 software recording channels as standard, freely assignable between 6 process groups. Up to 24 channels can be assigned to 1 process group.
- 4 alarms and 2 totalizers (if totalizer option is enabled) are assigned to each recording channel.
- Signal sources derived from universal analog inputs, MODBUS communications, digital inputs or internal analog and digital signals.
- Any source can be assigned to any recording channel.
- Data from assigned sources can be displayed in:
 - Vertical or horizontal Chart view format
 - Bargraph view format
 - Indicator view format with optional integrated Bargraph view
 - Indicator overview of all recording channels
- 3 logs record alarm events, totalizer values and system / configuration changes.
- MODBUS TCP – communicate with MODBUS master and slave devices over an ethernet LAN.
- MODBUS (RS485) (optional) – enables communication with MODBUS master devices over a 2- or 4-wire RS485 network.
- Internal flash memory for the storage of recorded data.
- The ability to archive data internally or to external archive media in binary format.
- Integrated web server and file transfer protocol (FTP) support for remote monitoring and data acquisition.
- The ability to store batch data (if batch option is enabled).
- Math and Logic (if Math and Logic option is enabled).
- Screen capture facility – saves an image of the operator views to external archive media, providing external archive media with sufficient free space is inserted in the recorder. It is not necessary for Logging to be online.
- USB connections enable peripherals (for example, keyboards and barcode scanners) to be connected.

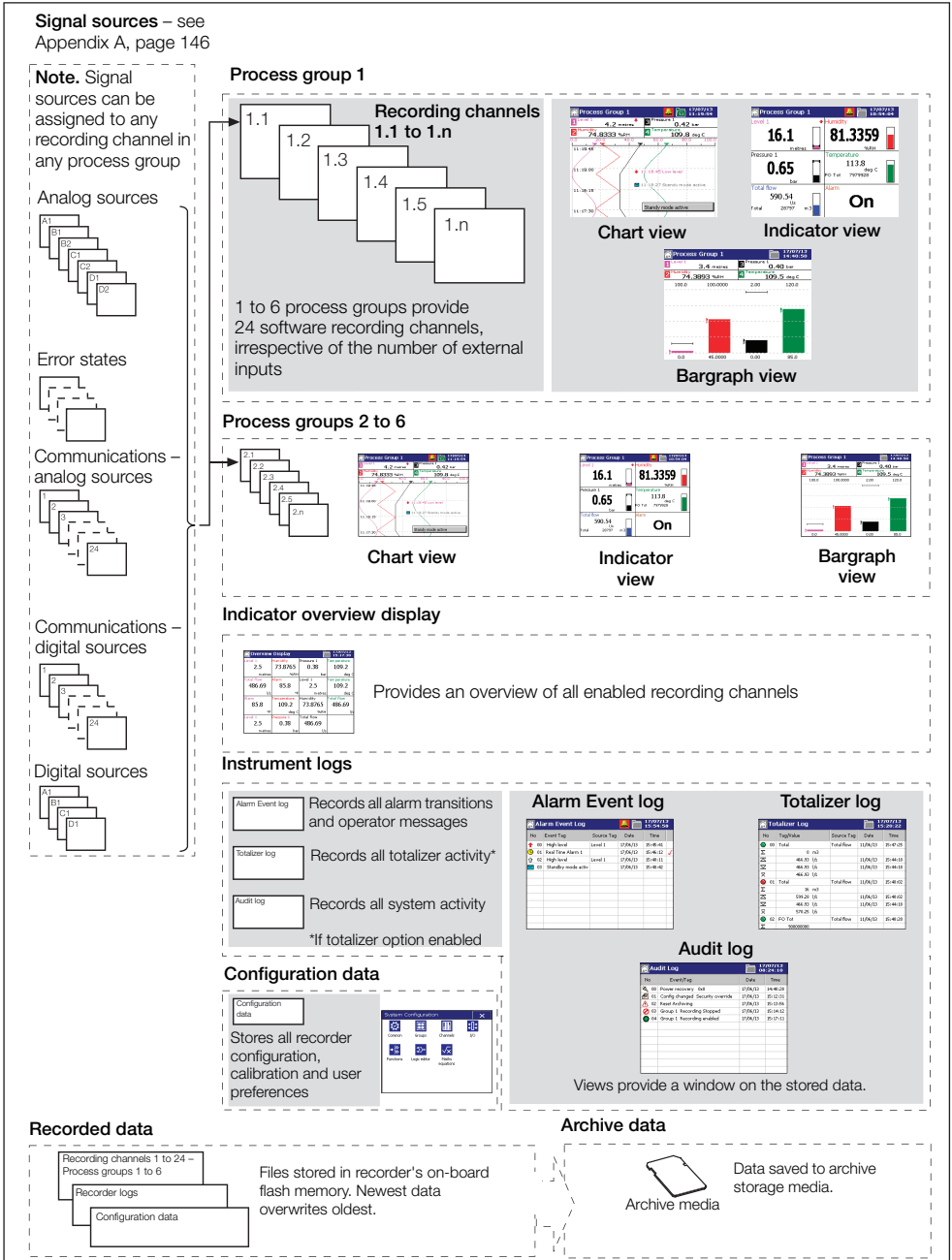

Fig. 2.1 Functional Overview

3 Installation

EC Directive 89/336/EEC

In order to meet the requirements of EC Directive 89/336/EEC for EMC regulations, this product must not be used in a non-industrial environment.

Cleaning

The front of the recorder can be hosed down if it has been installed in a panel correctly – see Fig. 3.4, page 13. Warm water and a mild detergent can be used.

3.1 Siting

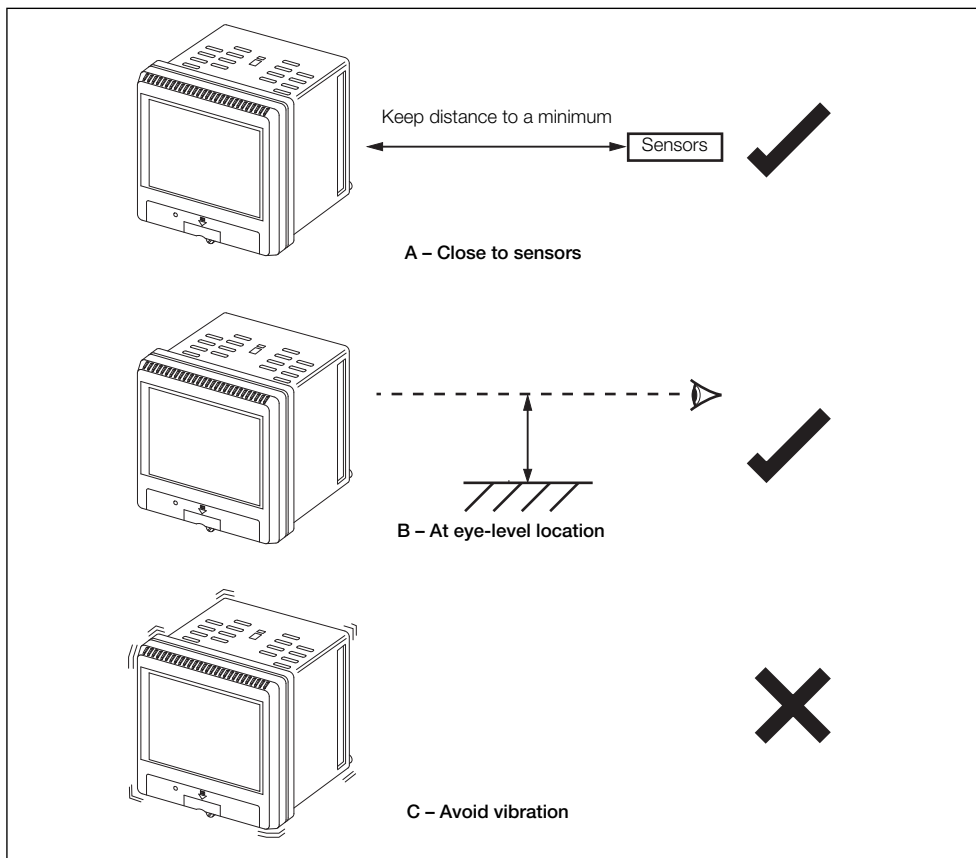

Fig. 3.1 General siting requirements

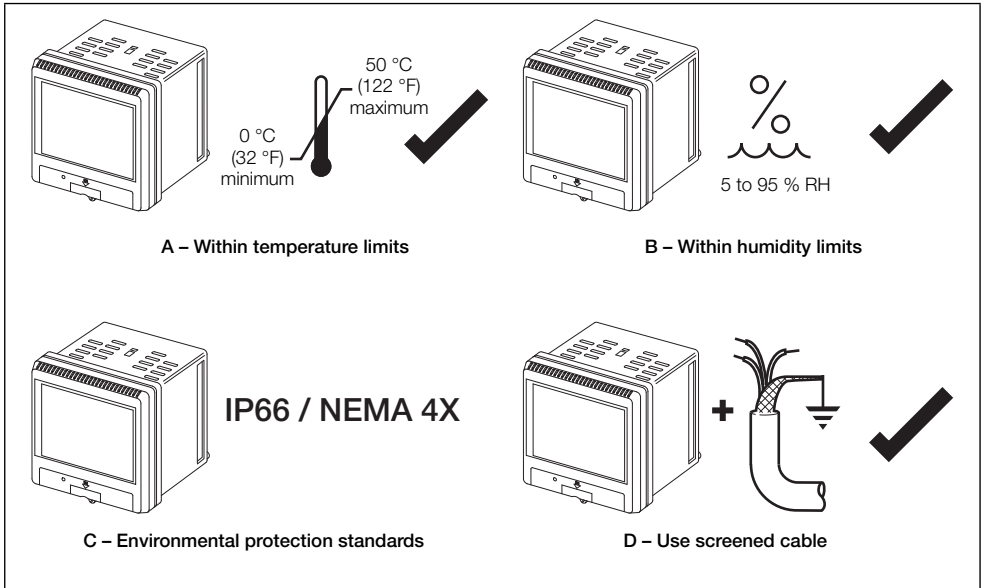

Fig. 3.2 Environmental requirements

Warning.

- Locate the recorder in a position where its temperature and humidity specification are not exceeded and ensure it is suitably protected from direct sunlight, rain, snow and hail.
- Select a location away from strong electrical and magnetic fields. If this is not possible, particularly in applications where mobile communications equipment is expected to be used, screened cables within flexible, earthed metal conduit must be used.

3.2 Mounting

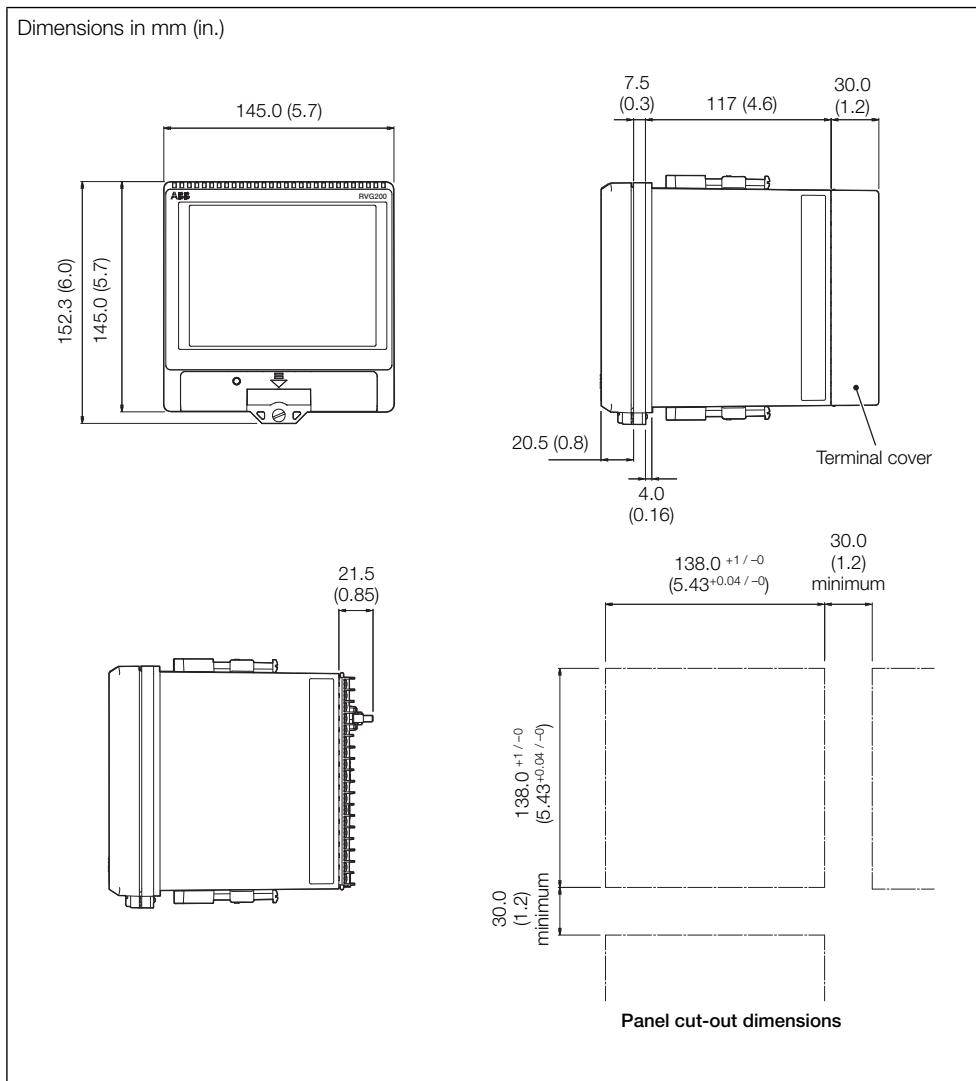

Fig. 3.3 Mounting dimensions

Referring to Fig. 3.4, secure the recorder in a panel as follows:

- ① Cut the correct sized hole in the panel – see Fig. 3.3, page 12.
- ② Insert the recorder into the panel cut-out.
- ③ Fit upper and lower panel clamps.
- ④ Tighten the clamping screws evenly and securely to a torque of 20 Nm (177 lbf.in).

Caution. Correct tightening of the clamping screws is critical in order to ensure proper compression of the panel seal and achieve the IP66 / NEMA 4X hose-down rating.

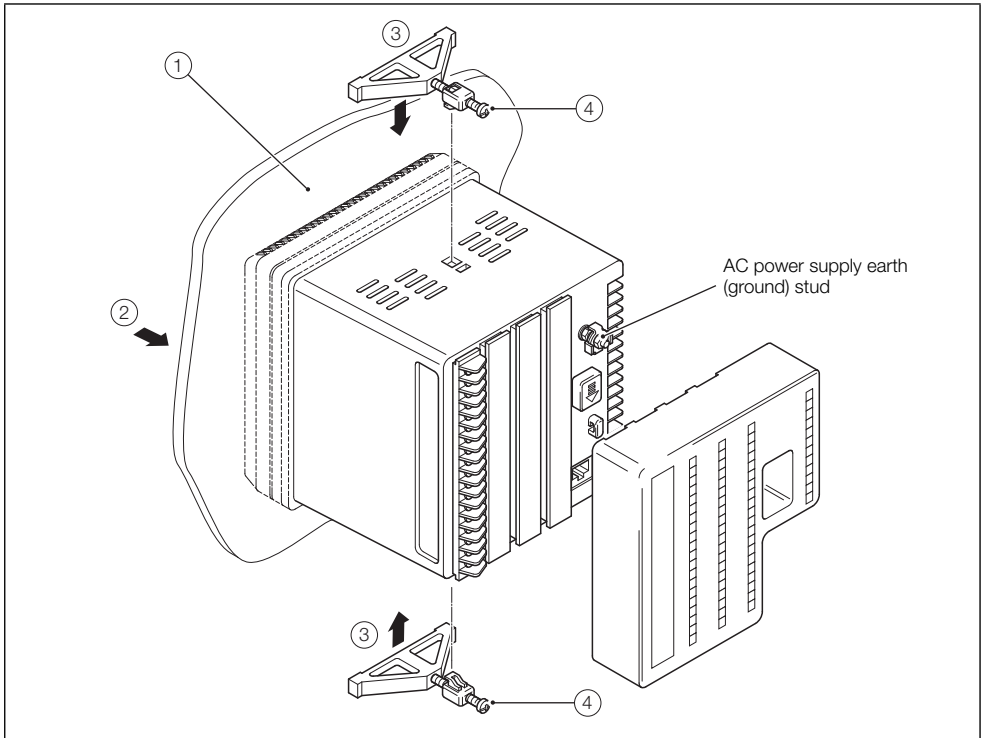

Fig. 3.4 Installing the recorder

3.3 Electrical connections

Warning.

- The recorder is not fitted with a switch therefore a disconnecting device such as a switch or circuit breaker conforming to local safety standards must be fitted to the final installation. It must be fitted in close proximity to the recorder within easy reach of the Operator and must be marked clearly as the disconnection device for the recorder. A fuse must be fitted in accordance with Fig. 3.7, page 19.
- Remove all power from supply, relay and any powered control circuits and high common mode voltages before accessing or making any connections.
- Use cable appropriate for the load currents: 3-core cable rated 3 A and 90 °C (194 °F) minimum, that conform to either IEC 60227 or IEC 60245. The terminals accept cables from 0.8 to 2.5 mm² (18 to 14 AWG).
- The recorder conforms to Installation Category II of IEC 61010.
- All connections to secondary circuits must have basic insulation.
- After installation, there must be no access to live parts, for example, terminals.
- Terminals for external circuits are for use only with equipment with no accessible live parts.
- If the recorder is used in a manner not specified by the Company, the protection provided by the equipment may be impaired.
- All equipment connected to the recorder's terminals must comply with local safety standards (IEC 60950, EN601010-1).

Note.

- Always route signal leads and power cables separately, preferably in earthed (grounded) metal conduit.
- Use screened cable for signal inputs and relay connections.
- Replacement of the internal battery (type Varta CR2025 3V lithium cell) must be carried out by an approved technician only.
- For connection to mains input and relay contact outputs), use only suitably rated field wiring insulated copper conductors rated minimum 300 V, 14 AWG, 90C. Route wires through suitably rated flexible conduits and fittings.

3.3.1 Accessing the recorder's connection terminals

Referring to Fig. 3.5:

1. Press the terminal cover release plate in recess (A).
2. Pull terminal cover (B) away from the recorder body.

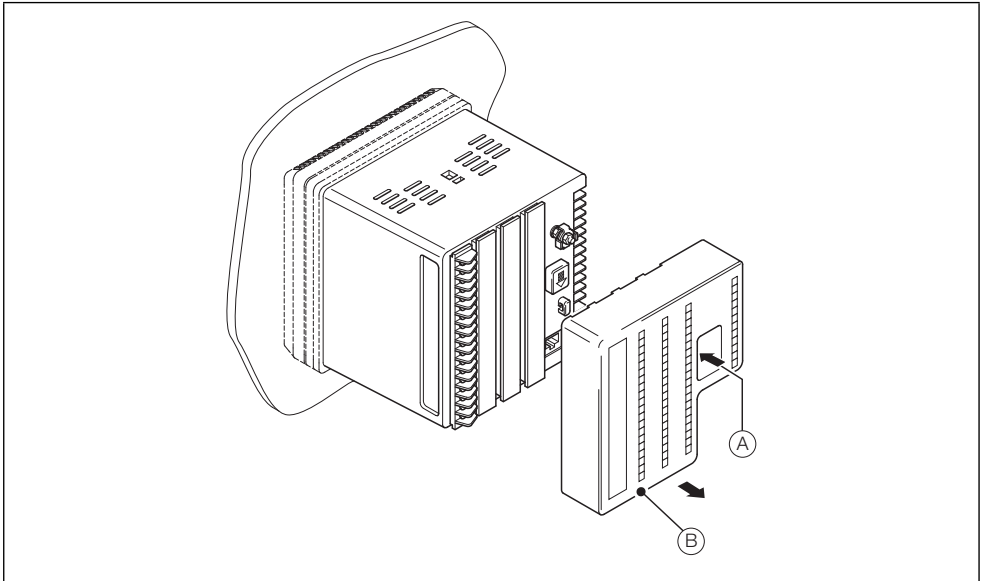

Fig. 3.5 Removing terminal cover

3.3.2 Analog input / relay / hybrid connections

Note.

- Tighten terminal screws to a torque of 0.1 Nm (0.9 lbf.in).
- Analog inputs:
 - 3-Lead RTD:
 - 3-leads must have equal resistance, not exceeding 20 Ω each
 - mA input types:
 - to ensure loop continuity when the recorder is switched off, fit a suitably rated diode (for example, type 1N4148 or equivalent)
 - using an external cold junction:
 - any channel can be used as the external cold junction for any thermocouple. When a thermocouple channel is using an external cold junction RTD, the thermocouple channel must have the shorting link RVG200/0118 fitted instead of the thermistor assembly

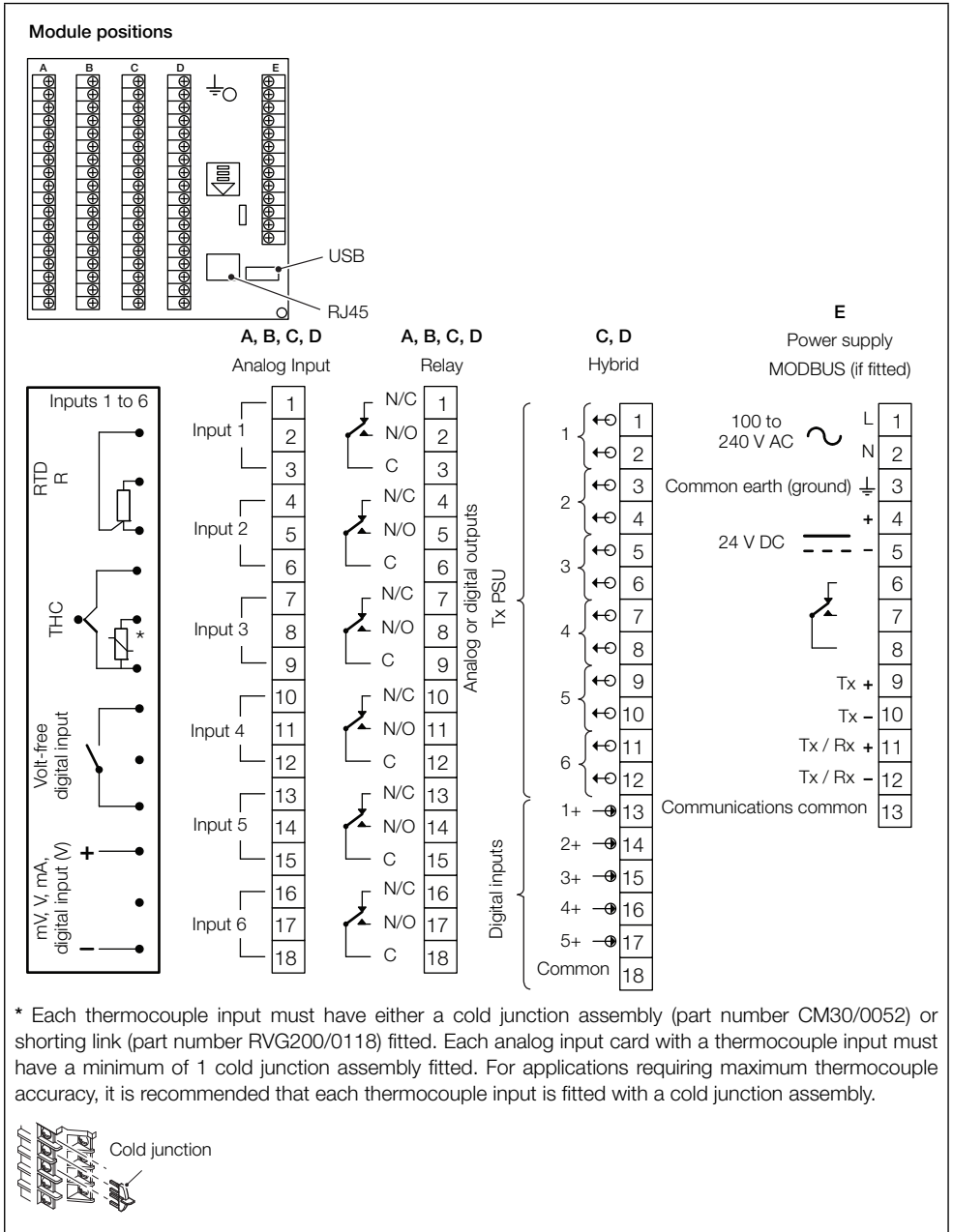

Fig. 3.6 Electrical connections

3.4 Analog / digital input module

Note. Tighten analog / digital input terminal screws to a torque of 0.1 Nm (0.9 lbf.in).

3.4.1 Thermocouple

Use the correct compensating cable between the thermocouple and the terminals – see Table 3.1.

Automatic cold junction compensation (ACJC) is incorporated but an independent cold (reference) junction may be used.

Thermocouple type	Compensating cable											
	BS1843			ANSI MC 96.1			DIN 43714			BS4937 Part No.30		
	+	-	Case	+	-	Case	+	-	Case	+	-	Case
Ni-Cr / Ni-Al (K)	Brown	Blue	Red	Yellow	Red	Yellow	Red	Green	Green	Green	White	Green *
Ni-Cr / Cu-Ni (E)	-			-			-			Violet	White	Violet *
Nicrisil / Nisil (N)	Orange	Blue	Orange	Orange	Red	Orange	-			Pink	White	Pink *
Pt / Pt-Rh (R and S)	White	Blue	Green	Black	Red	Green	Red	White	White	Orange	White	Orange *
Pt-Rh / Pt-Rh (B)	-			-			-			Grey	White	Grey *
Cu / Cu-Ni (T)	White	Blue	Blue	Blue	Red	Blue	Red	Brown	Brown	Brown	White	Brown *
Fe / Con (J)	Yellow	Blue	Black	White	Red	Black	Red	Blue	Blue	Black	White	Black *
* Case Blue for intrinsically safe circuits												
Fe / Con (DIN 43710)	-			-			DIN 43710			-		
							Blue / red	Blue	Blue			

Table 3.1 Thermocouple compensating cable

3.4.2 Resistance thermometer (RTD)

On applications requiring long leads it is preferable to use a 3-lead resistance thermometer.

If 2-lead resistance thermometers are used, each input must be calibrated to take account of the lead resistance.

3.5 Power supply connections

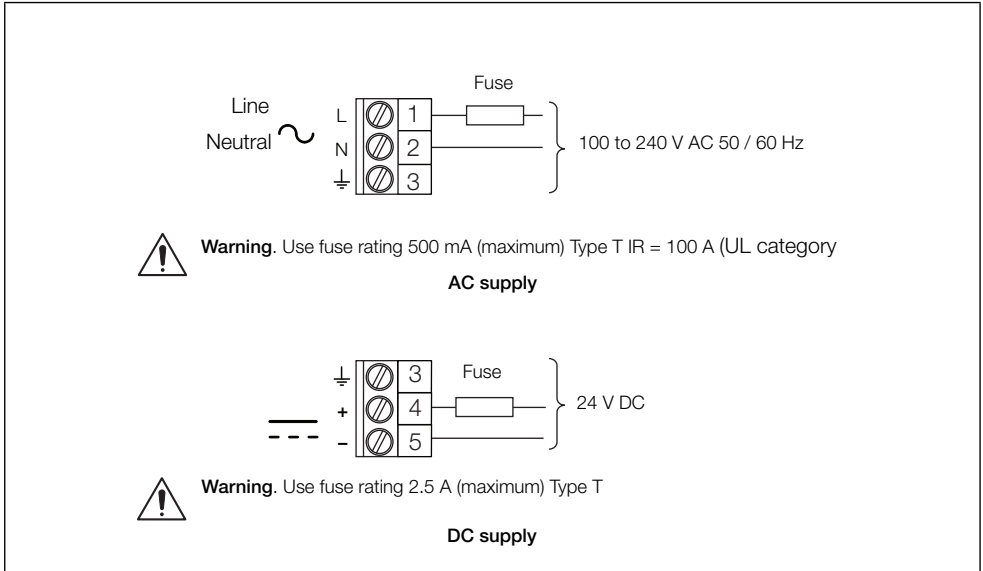

Fig. 3.7 Power supply connections

Note. Tighten power supply terminal screws to a torque of 0.1 Nm (0.9 lbf.in).

3.6 2-lead temperature transmitter connections

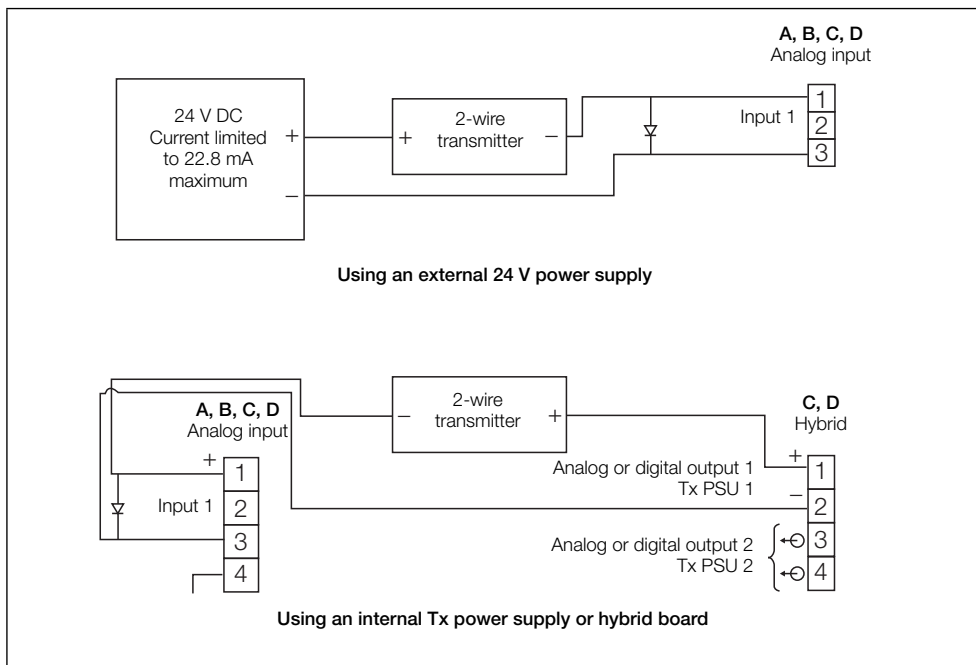

Fig. 3.8 2-lead temperature transmitter connections

3.7 Relays

One relay is provided as standard (position F). An additional relay module can be fitted in positions A, B, C or D to provide 6 additional relays per module.

The maximum individual relay current is 5A. The total load for all relays within the recorder must not exceed 36 A.

Relay contacts are fitted with arc suppression components as standard.

3.8 MODBUS module

A MODBUS module can be fitted internally to the power supply board in position E to provide a 2- or 4-wire isolated RS485 interface.

3.8.1 Host computer serial communications

The serial interface option module uses the MODBUS Remote Terminal Unit (RTU) Master / Slave protocol. An appropriate RS422 / 485 communications driver must fitted to the host (Master) computer. It is strongly recommended that the interface has galvanic isolation to protect the computer from lightning damage and to increase signal immunity to noise pick-up.

3.8.2 2- or 4-wire connection

MODBUS serial communications must be configured as 2-or 4-wire serial links – see Figs 3.9 and 3.10, respectively. The recorder must be added to the link configuration on the host system – refer to information supplied with the host system.

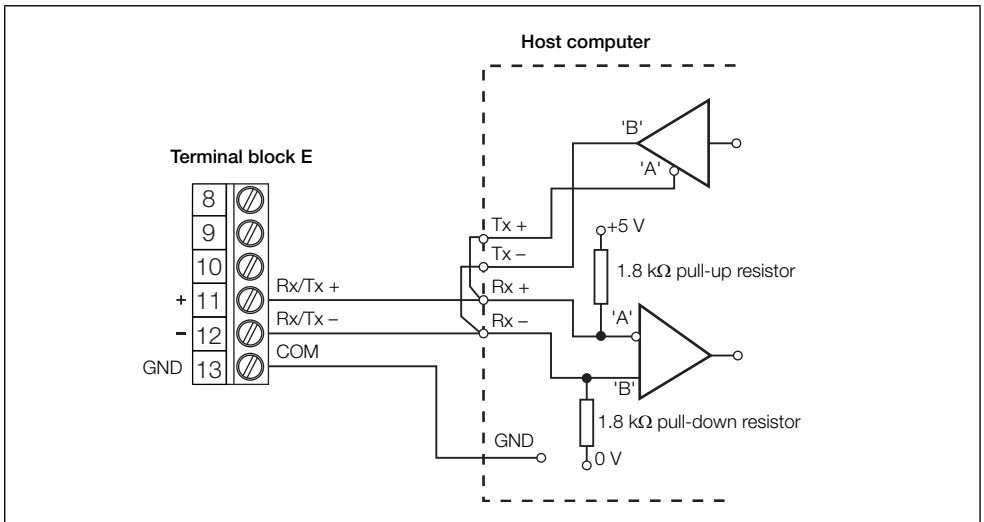

Fig. 3.9 2-wire connection

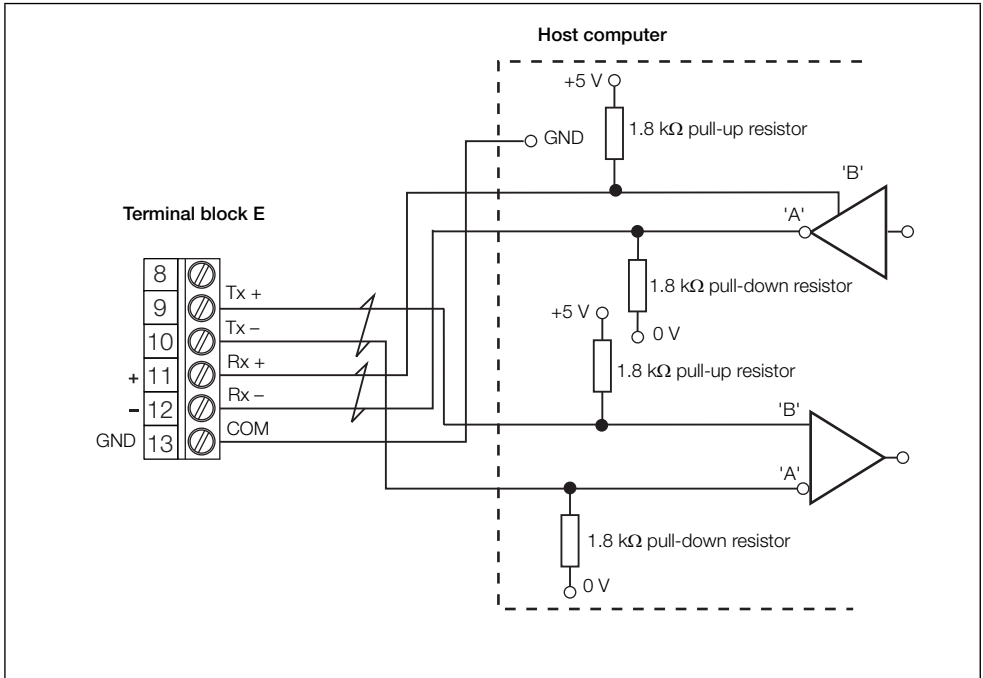

Fig. 3.10 4-wire connection

3.8.3 Pull-up and pull-down resistors

To prevent false triggering of slaves when the master (host computer) is inactive, pull-up and pull-down resistors are fitted to the MODBUS module.

3.8.4 Termination resistor

For long transmission lines, a termination resistor must be fitted to the last slave in the chain – see Fig. 3.11.

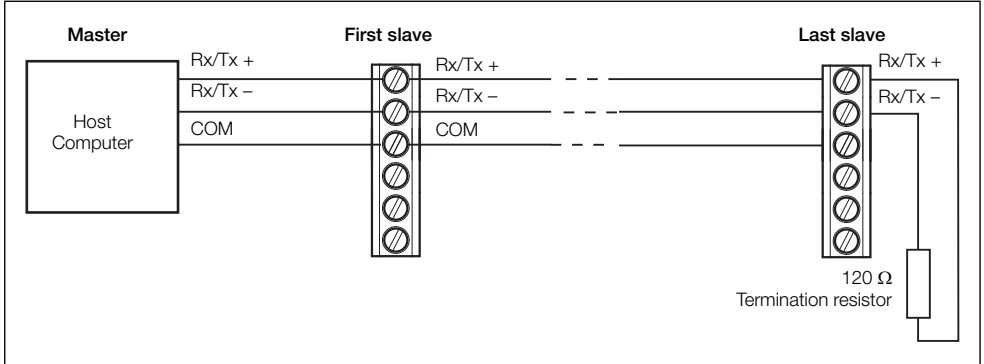

Fig. 3.11 Connecting multiple slaves

3.8.5 Serial Connections

4-wire connections to the MODBUS serial board must be made as shown in Fig. 3.10. Connections to 2-wire systems with multiple slaves must be made in parallel as shown in Fig. 3.9, page 21. When connecting cable screens, ensure that 'ground loops' are not introduced.

The maximum serial data transmission line length for both RS485 systems is 1200 m (3937 ft.). The types of cable that can be used are determined by the total line length:

- Up to 6 m (20 ft.) – standard screened or twisted pair cable.
- Up to 300 m (984 ft.) – twin twisted pair with overall foil screen and an integral drain wire.
- Up to 1.2k m (3937 ft.) – twin twisted pair with separate foil screens and integral drain wires.

4 Operation

The recorder is operated using the touchscreen.

4.1 Powering up the recorder

When power is first applied to the recorder a number of self-tests are performed and, if passed, the start-up screen is displayed.

At the end of the start-up sequence, the recorder displays the Operator view that was displayed when the recorder was powered down.

4.2 Front panel features

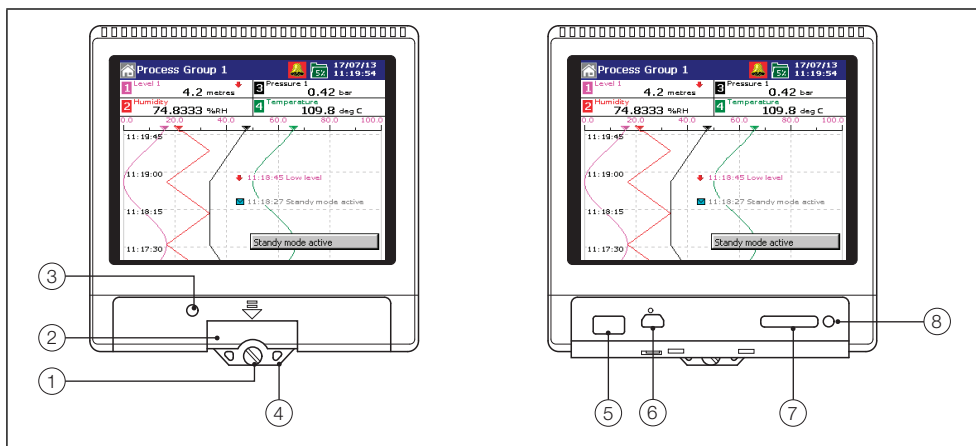

Fig. 4.1 Front panel features

Key to Fig. 4.1:

- ① Case securing screw
- ② Door release
- ③ Door lock
- ④ Tamper-evident seal attachment point
- ⑤ USB port
- ⑥ Service port
- ⑦ SD card slot
- ⑧ Archiving active indicator light (do not remove media when lit)

4.3 Navigating views and groups

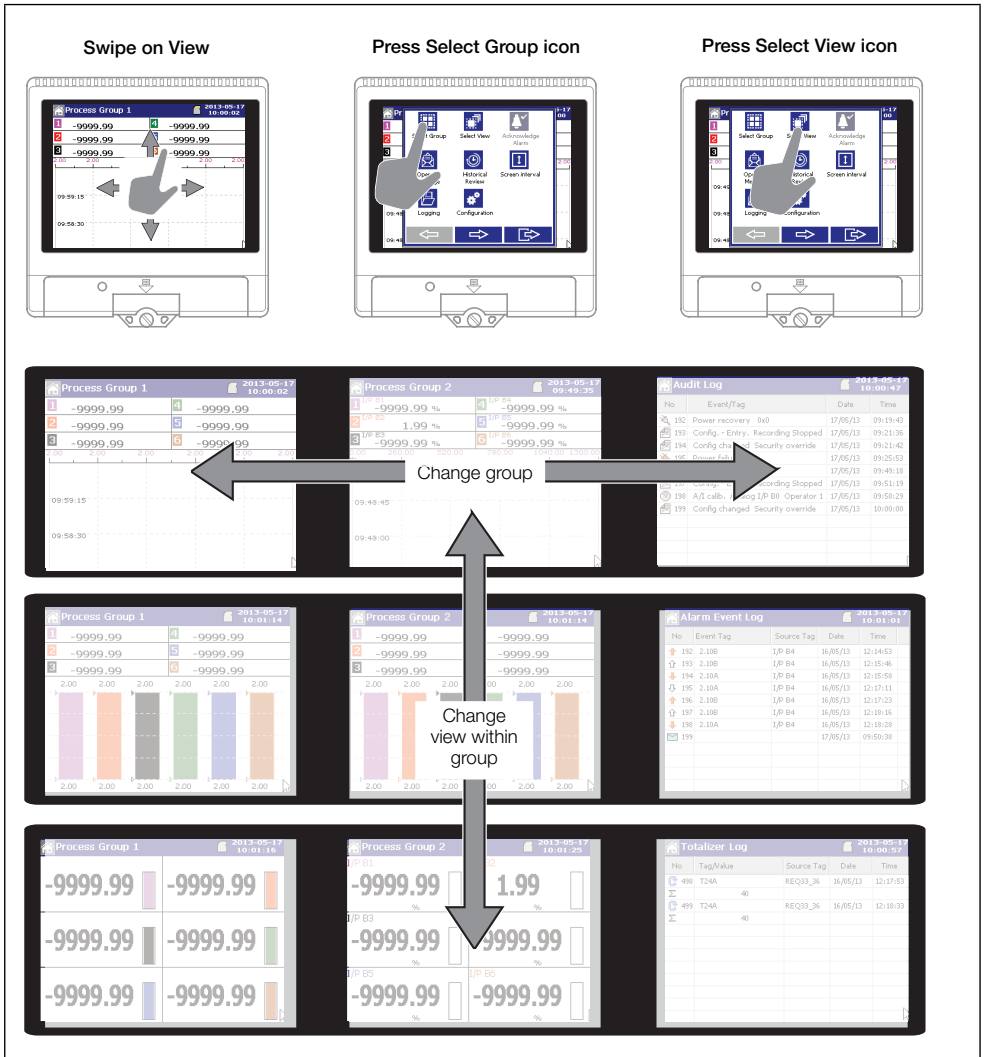

Fig. 4.2 Navigating groups and views

Note. Only process groups and views that are enabled are displayed.

4.4 Operator menu overview

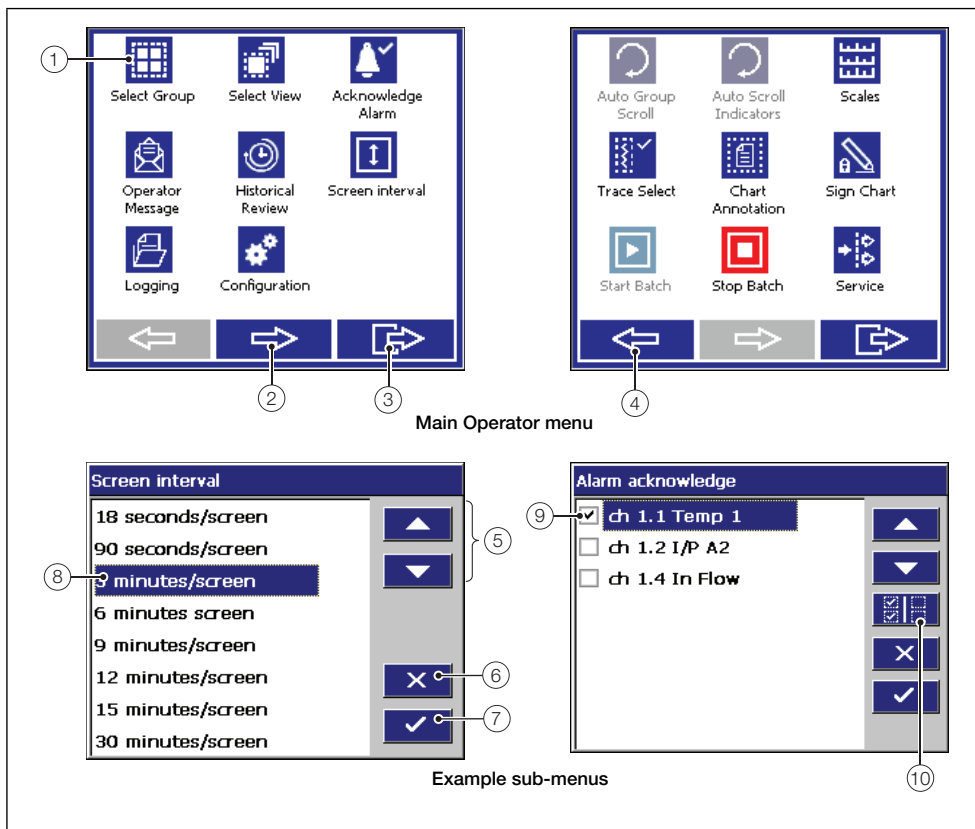

Fig. 4.3 Operator menu overview

Key to Fig. 4.5:

- ① Menu item.
Note. Unavailable menu items are greyed-out.
- ② Touch to advance to next menu.
- ③ Touch to exit and return to the Operator display.
- ④ Touch to return to previous menu.
- ⑤ Touch to scroll up and down and highlight an item in the list.
- ⑥ Touch to discard changes and return to the Operator display.
- ⑦ Touch to accept changes and return to the Operator display.
- ⑧ Selected list item.
Note. An item can also be selected directly by touching it.
- ⑨ Selected tick-box item.
- ⑩ Touch to select / deselect all.

4.4.1 Navigating menus

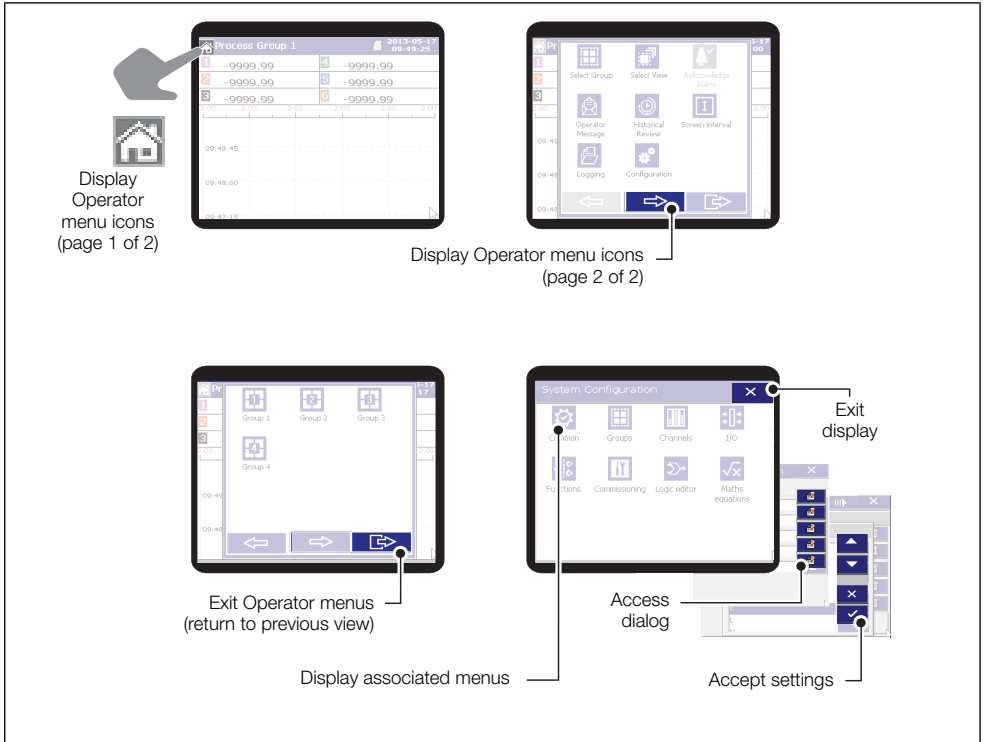

Fig. 4.4 Navigating menus

4.5 Operator views

4.5.1 Chart view

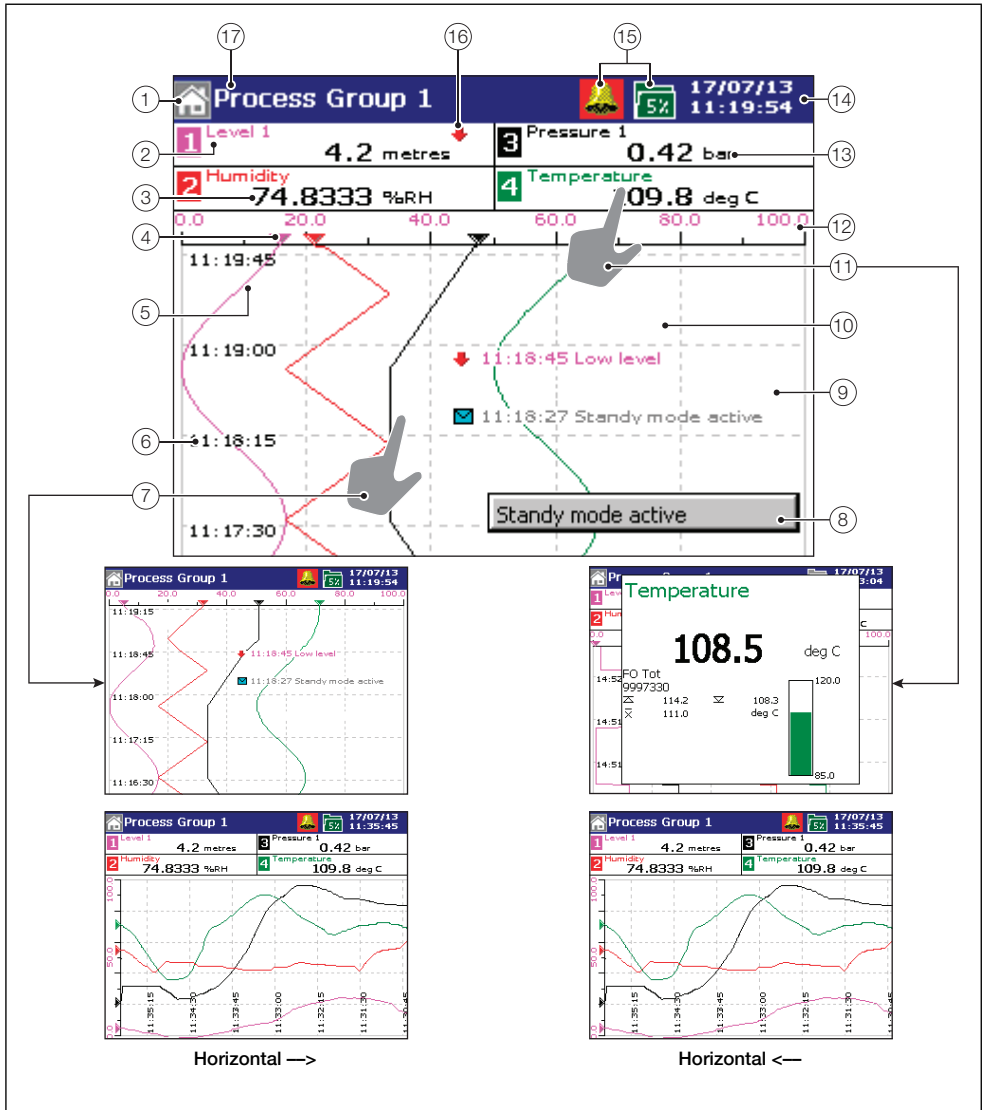

Fig. 4.5 Vertical and horizontal chart views

Key to Fig. 4.5:

- ① Main menu (home) button.
- ② Channel tag.
- ③ Current value – see **Note 1**, page 30.
- ④ Trace pointer – see **Note 2**, page 30.
- ⑤ Channel trace – see **Note 2**, page 30.
- ⑥ Time stamp.
- ⑦ Touch the chart to close the channel indicators and expand the chart area.
Touch the chart again to restore the channel indicators.
- ⑧ Operator message or electronic signature (displayed for 1 second)
- ⑨ Operator message annotation – see **Note 3**, page 30.
- ⑩ Alarm event annotation – see **Note 3**, page 30.
- ⑪ Touch an indicator to display a pop-up showing all available information for that channel.
Touch the pop-up to close it.
- ⑫ Scale bar.
- ⑬ Engineering units.
- ⑭ Current date and time.
- ⑮ Status icons – see **Note 4**, page 30.
- ⑯ Alarm active icon.
- ⑰ Process group name.

Note.

- Do not remove media when the archiving active indicator light is lit – see Fig. 4.1, page 24.
- Always set the external media off-line before removing it – see Section 6.1, page 54.

Note.

1. Current values

The current value is the latest instantaneous value and its update rate is not affected by the recording sample rate.

If the current value is displayed in red recording has been stopped for that channel via a digital signal – see Section 7.8.1, page 80.

Traces are displayed only when recording is active for that process group. If recording is set to *Stop*, the traces continue to be displayed for up to one sample period and are then turned off.

2. Trace pointers and channel traces

The trace pointers and channel traces are displayed in the color assigned to each channel. Trace pointers may be disabled during configuration – see Section 7.8.2, page 82.

3. Alarm event, operator message and electronic chart signature annotations

Alarm event, operator message and electronic chart signature annotations are not shown on the chart unless enabled – see **Chart Annotation** on page 43 and Section 7.8.2, page 82.

If Alarm event annotation is enabled and an alarm becomes active, an alarm event icon is displayed at the point at which the alarm occurred, together with the alarm time and tag, for example:



 11:58:00 1.1A High Level

If more than one alarm occurs in the same sample period:

- and a second alarm on a channel becomes active, its icon is added behind the first.
- and more than one operator message is active (maximum 24), a second icon is added behind the first.
- the new alarm event icons appear to the left of earlier icons.
- the time and tag of the oldest alarm (right-most icon) only is displayed.

4. Alarm Status

- Flashing alarm event icon – alarm active and unacknowledged
- Continuous alarm event icon – alarm active and acknowledged

If **any** alarm in **any** process group is active, the Global Alarm status icon () is displayed in the status bar – see item (15) in see Fig. 4.5, page 28. If **any** active alarm in **any** process group is unacknowledged, the icon is surrounded by a flashing border (.

4.5.2 Indicator view

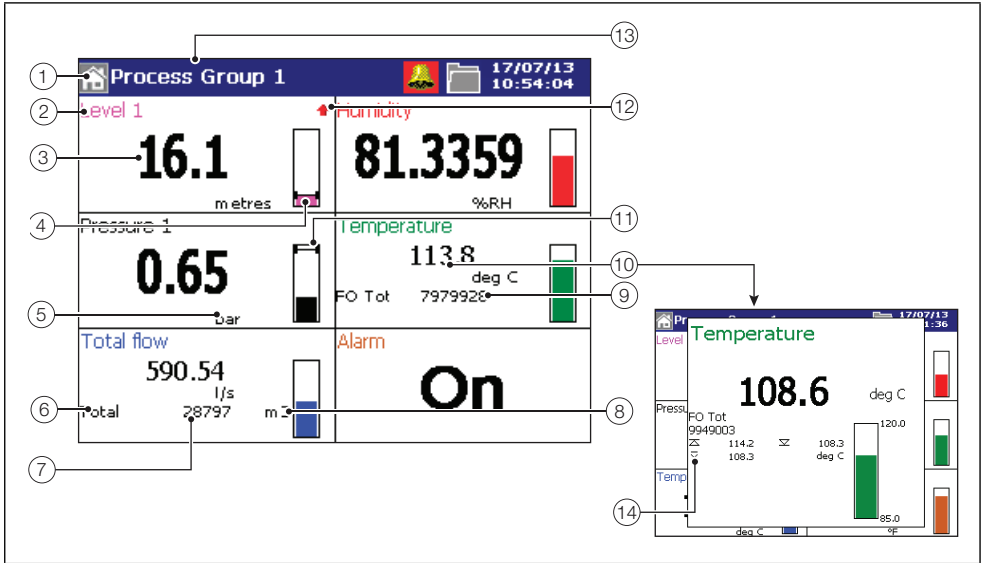

Fig. 4.6 Indicator view

Key to Fig. 4.6:

- (1) Main menu (home) button.
- (2) Channel tag.
- (3) Current value – see **Note 1**, page 30.
- (4) Bargraph.
- (5) Channel units.
- (6) Totalizer tag.
- (7) Totalizer value.
- (8) Totalizer units.
- (9) Fo value / units – see Section 7.9.6, page 108.
- (10) Touch an indicator to display a pop-up showing all possible information for that channel. Touch the pop-up to close it.
- (11) Alarm trip level (not shown for slow and fast rate alarms).
- (12) Alarm active icon.
- (13) Process group name.
- (14) Maximum, minimum and average totalizer values.

Note.

- Do not remove media when the archiving active indicator light is lit – see Fig. 4.1, page 24.
- Always set the external media off-line before removing it – see Section 6.1, page 54.

4.5.3 Bargraph view

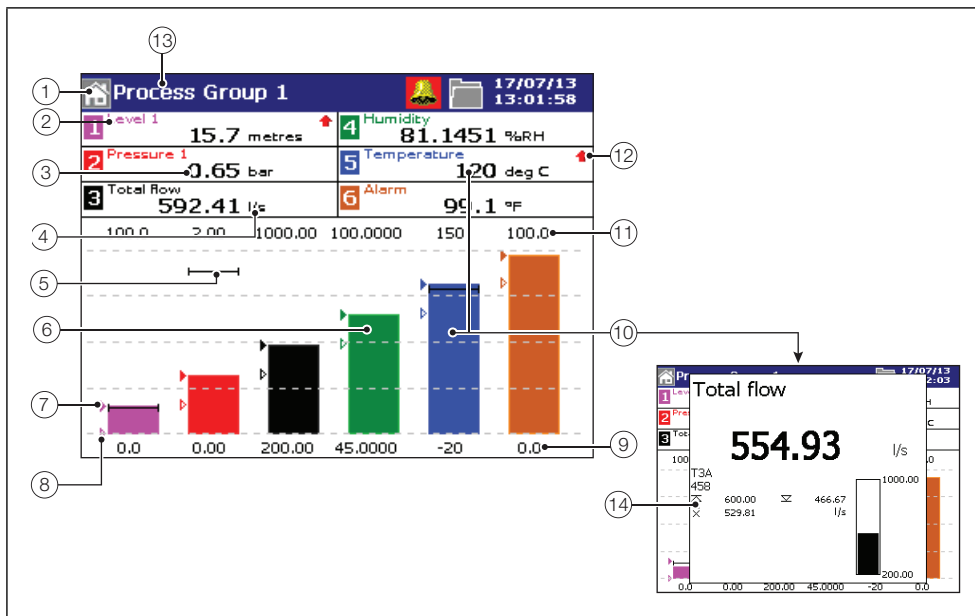

Fig. 4.7 Bargraph view

Key to Fig. 4.7:

- ① Main menu (home) button.
- ② Channel tag.
- ③ Current value – see **Note 1**, page 30.
- ④ Channel units.
- ⑤ Alarm trip level (not shown for slow and fast rate alarms).
- ⑥ Bargraph.
- ⑦ Maximum value (solid fill).
- ⑧ Minimum value (white fill).
- ⑨ Engineering range low value.
- ⑩ Touch a bargraph or its associated indicator to display a pop-up showing all possible information for that channel. Touch the pop-up to close it.
- ⑪ Engineering range high value.
- ⑫ Alarm active icon.
- ⑬ Process group name.
- ⑭ Maximum, minimum and average totalizer values.

Note.

- Do not remove media when the archiving active indicator light is lit – see Fig. 4.1, page 24.
- Always set the external media off-line before removing it – see Section 6.1, page 54.

4.5.4 Overview display

Note. The overview display provides an overview of all configured recording channels in all configured process groups.

All configured channels are displayed in order starting with the first configured channel in process group 1 at the top left of the screen. This is followed by the remaining channels in process group 1, then process group 2 channels, process group 3 channels etc.

Overview Display			06/09/14 16:10:11	
Temp 1 81.1 ↑ °C	Oxvaen 1 19625 ppm	Flow 1 414444 l/d	Level 1 25.6 cm	
Pressure 1 38.8 psi	Pump On	Temp 2 23.6 °C	Temp 3 56.8 °C	
Temp 4 87.4 °C	Temp 5 75.2 °C	Temp 6 13.0 °C	Temp 7 27.1 °C	
Temp 8 64.5 °C	Temp 9 48.6 °C	Temp 10 22.9 °C	Temp 11 71.5 °C	
Temp 12 68.2 °C	Temp 13 12.4 °C	Temp 14 65.2 °C	Temp 15 64.2 °C	
Temp 16 62.8 °C	Temp 17 66.5 °C	Temp 18 61.0 °C	Temp 19 68.3 °C	

Fig. 4.8 Overview display

4.6.2 Totalizer log

Note.

- The Totalizer log view is displayed only if the Totalizer option has been enabled in the software.
- The Totalizer log view provides an historical log of totalizer activity. To view the current totalizer status, choose the Indicator view.
- When the number of entries in the Totalizer log has reached 500, the oldest data is overwritten by the newest. Entries are renumbered so that the number of the oldest entry is always 00.
- The logging of totalizer values can be triggered at pre-determined intervals and / or by digital signals – see **Log update**, page 105.

No	Tag/Value	Source Tag	Date	Time
00	Total	Total flow	11/06/13	15:47:25
	0 m3			
	466.93 l/s		11/06/13	15:44:18
	466.93 l/s		11/06/13	15:44:18
	466.93 l/s			
01	Total	Total flow	11/06/13	15:48:02
	16 m3			
	599.28 l/s		11/06/13	15:48:02
	466.93 l/s		11/06/13	15:44:18
	570.25 l/s			
02	F0 Tot	Total flow	11/06/13	15:48:26
	900000000			

Fig. 4.10 Totalizer log

Key to Fig. 4.10:

- ① Log entry number.
- ② Totalizer icon (green = start; red = stop).
- ③ Batch total at the time of the event.
- ④ Maximum, minimum and average of the value being totalized at the time of the event.
- ⑤ F0 totalizer entry – see Section 7.9.6, page 108.
- ⑥ Touch the screen here to view the next page of data.
- ⑦ Newest data.
- ⑧ Date / time at which the maximum and minimum flowrates occurred.
- ⑨ Oldest data – touch the screen here to view the previous page of data.

Note. Maximum, minimum and average statistics are not shown unless enabled in the 'Filter Select' parameter – see page 47.

4.6.3 Audit log

Note.

- The Audit log view provides an historical log of system activity.
- When the number of entries in the Audit log has reached 200, the oldest data is overwritten by the newest. Entries are renumbered so that the number of the oldest entry is always 00.

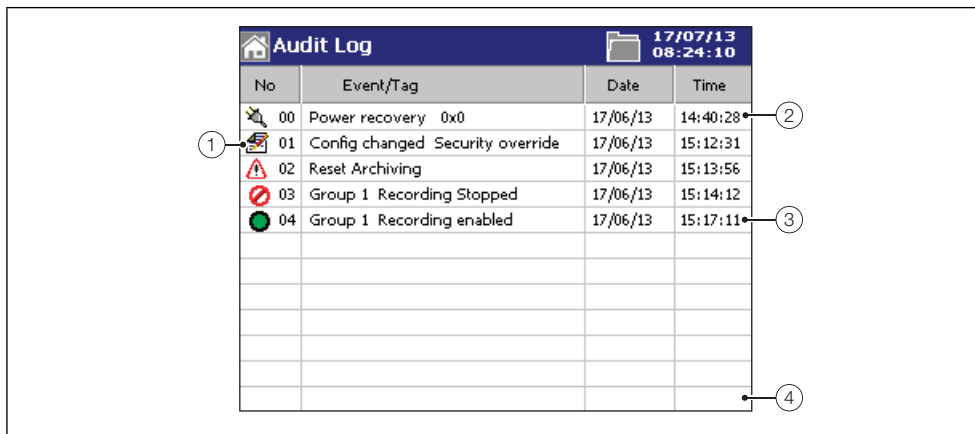

Fig. 4.11 Audit log

Key to Fig. 4.11:

- ① Audit log icon.
- ② Oldest data – touch the screen here to view the previous page of data.
- ③ Newest data
- ④ Touch the screen here to view the next page of data.

4.7 Operator menu system

Note. The following menu items are available from **all** operator **and** log views.



Touch to display the Operator menu



Select Group

Touch to display the sub-menu.

Note. The group displayed can also be changed by swiping right-to-left (to increment) or left-to-right (to decrement) across the touchscreen – see Fig. 4.2, page 25.



Group 1 (to 6)

Touch to select a group to display.

Note. Only icons for configured and enabled groups are displayed.



Select View

Touch to display the sub-menu.

Note. Icons for views that are not enabled are greyed-out.



Chart View

Touch to display the Chart view for the selected group.



Indicator View

Touch to display the Indicator view for the selected group.



Bargraph View

Touch to display the Bargraph view for the selected group.



Alarm Log

Touch to display the alarm log.



Totalizer Log

Note. Greyed-out if totalizer software option is not enabled.

Touch to display the Totalizer log.



Audit Log

Touch to display the audit log.



Overview Display

Touch to display the overview display.



Screen Capture

Note. Greyed-out if **Screen Capture** is set to *Disabled* (see page 71) or external archive media is not inserted or is full.

Touch to capture an image of the current Operator screen.

Images are saved to external archive media in a folder named 'BMP' within the 'VRD' folder.



Logging

See Section 5.2, page 52.



Configuration

Touch to configure the recorder – see Section 7, page 59.

Note. The following menu items are available only from the views listed below the parameter name.





Acknowledge Alarm

Chart, indicator, bargraph and overview display views only

Note.

- If **Security system** is set to *Advanced* and **Acknowledge Security** is set to *On* (see Section 7.7.5, page 74), alarms can be acknowledged only by Users with alarm acknowledgement privileges – see Section 7.7.6, page 76.
- Greyed-out if the relevant **Alarm Acknowledge** menu enable is not selected (chart, indicator and bargraph views only – see pages 83, 84 and 85 respectively) or **Overview Alarm Ack.** is not set to *Enabled* (overview display only – see page 71).

Alarms can be acknowledged individually or all active alarms in the current process group can be acknowledged simultaneously by touching  followed by .

Note. Active unacknowledged alarms in the current process group are identified by a flashing Alarm Event icon to the right of the associated channel reading. Active acknowledged alarms are identified by a continuous Alarm Event icon – see item (16) in Fig. 4.5, page 28.

Note.

- If an alarm in **any other** process group is active, the Global Alarm status icon () continues to be displayed in the status bar. If an active alarm in **any other** process group is unacknowledged, the icon is surrounded by a red flashing border.
- If **Acknowledge Timeout** is set to *On* (see Section 7.9.4, page 101) and the alarm condition for an acknowledged alarm is not cleared within the configured timeout period, the acknowledge state is reset to active / unacknowledged.



Only active, configured alarms are displayed in the menu.



Group 1 (to 6)

Alarm Event log view only

The Alarm Event log is not group specific. To acknowledge a particular alarm, first select the relevant process group, followed by the alarm to be acknowledged. If a group does not contain any configured alarms, its icon is greyed-out.

To acknowledge all active alarms in the selected process group simultaneously, touch  followed by .

Note. If **Acknowledge Timeout** is set to *On* (see Section 7.9.4, page 101) and the alarm condition for an acknowledged alarm is not cleared within the configured timeout period, the acknowledge state is reset to active / unacknowledged.

Alarms that have not been configured are not displayed in the menu.



Operator Message

Chart, indicator and bargraph views only

Note. Greyed-out if the relevant **Operator message** menu enable is not selected – see pages 83 (Chart view), 84 (Indicator view) or 85 (Bargraph view) as applicable.

Touch to add one of 24 predefined Operator Messages (see Section 7.7.7, page 79) or one User-Defined Message to the Alarm Event log.

If < **user defined** > is selected, a data entry keyboard is displayed to enable the message to be entered (see Fig. 7.6, page 65).

The selected or user-defined message is displayed briefly on screen. If **Operator Messages** annotation is selected (see **Chart Annotation** on page 82) the message is also added to the chart.

Note. When the recorder is in Historical Review mode, Operator Messages generated are added at the current time, not the time indicated by the cursor.

 **Historical Review**
Chart views only

Note. Greyed-out if the **Historical review** menu enable is not selected – see page 83.

Touch to display the sub-menu.



 Enter/Exit

Touch to view previously recorded data stored in the recorder's onboard memory for the group currently displayed.

Touch the bottom left or top right corners of the chart to move forward and backward through the recorded data.

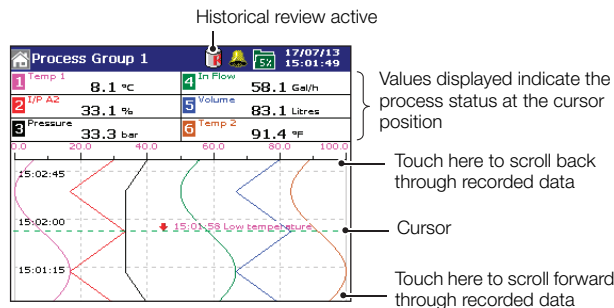
Note. Previously recorded data for another group can be viewed if the group is enabled and displayed.



To exit historical review and return to the real-time recording display, touch  to display the sub-menu and touch  again.

Note. Swiping the screen in any direction also exits Historical Review mode.

Note.

While in historical review mode:

- Recording of new data continues unless stopped from the **Logging** menu – see Section 5.1, page 49.
- The current value is replaced by '- - -' when the historical data is invalid (for example, when recording was stopped).
- If the trace at the cursor position represents more than one sample, the indicators flash between the maximum and minimum values of those samples.
- Menu options remain active – enabling the screen interval to be changed, different scales and channels to be selected, etc.
- Operator messages generated are added to the Alarm Event log at the present time, not the time indicated by the cursor.
- All data stored in the recorder's internal memory can be viewed.
- The display can be scrolled back to the start of the oldest data.
- Archiving to removable media is suspended but all data recorded in the internal memory buffer during this time is archived automatically on exiting Historical Review mode.

 Goto

Touch to move to data stored in the recorder's onboard memory that was recorded at a specific date and time.

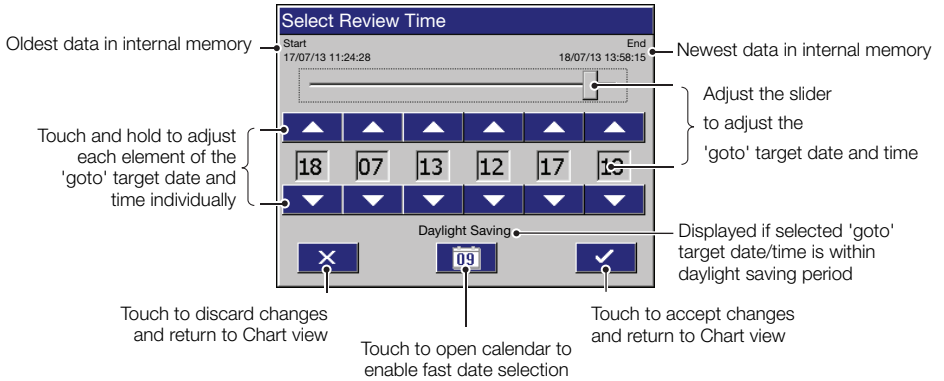

Note.

- If daylight saving is enabled (see Section 7.7.4, page 72) **and** the selected Goto target date / time is within the daylight saving period, 'Daylight Saving' is displayed on the dialog box.
- Once internal memory becomes full, the oldest data is overwritten by the newest data. If historical review has been selected for some time, the oldest data present may no longer be available.
- The recorder exits historical review mode automatically after 15 minutes if the screen is not touched.

 Select Batch

Select to move to data recorded in the recorder's onboard memory for a specific batch – see Appendix E.2.4, page 176.

i **Screen Interval**

Chart views only

Note. Greyed-out if the **Screen interval select** menu enable is not selected – see page 83.

Touch to change the amount of data displayed on the screen. A longer screen interval displays more data, a shorter screen interval displays data over a shorter time period, but in more detail. In both cases, the full trace is preserved by plotting the maximum and minimum samples for each display point.

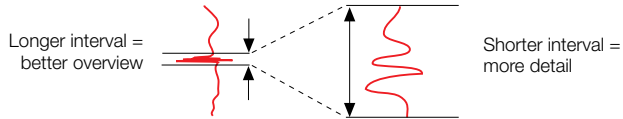

The screen intervals available in the menu are determined by the faster of the primary and secondary sample rates set for the process group during configuration – see Section 7.8.1, page 80.

Table 4.1 shows the relationship between sample rate and screen interval for the vertical and horizontal chart views.

Note.

- A 'Please Wait' message appears in the status bar while the recorder retrieves data from storage.
- Selecting a different screen interval does not affect the rate at which data is sampled.
- When in historical review mode, changing the screen interval causes the time at the cursor position to change.

Sample rate setting	Maximum screen interval	
	Vertical chart view	Horizontal chart view
<1 second	Up to 1 hour / screen	Up to 1.5 hours / screen
More than 1 second, less than 4 seconds	Up to 12 hours / screen	Up to 21 hours / screen
More than 4 seconds, less than 8 seconds	Up to 1 days / screen	Up to 1.5 days / screen
More than 8 seconds, less than 12 seconds	Up to 2 days / screen	Up to 3 days / screen
More than 12 seconds, less than 28 seconds	Up to 3 days / screen	Up to 4.5 days / screen
More than 28 seconds	Up to 7 days / screen	Up to 12 days / screen



Table 4.1 Sample rates and screen intervals



Auto Group Scroll

Chart, indicator, bargraph and overview display views only

Note. Greyed-out if one process group only is enabled.

Touch to display the current view for each configured process group in turn for 20 seconds. The Auto Group Scroll icon () is displayed in the status bar at the top of the screen when AutoView Scroll is active. Touch the  button or swipe the screen to cancel Auto Group Scroll.



Auto Scroll Indicators

Chart and bargraph views only

Note. Greyed-out unless more than 6 recording channels are assigned to the process group currently being viewed.

Touch to enable automatic scrolling of the channel indicators.



Scales

Chart views only

Note. Greyed-out if the **Scale select** menu enable is not selected – see page 83.

Touch to select a channel scale to be displayed in the scale bar at the top of the chart window. For digital channels, the On and Off tags are displayed at the corresponding position on the scale bar.

Select **Auto Scroll** to display the scale for each enabled channel in turn for 36 seconds.



Trace Select

Chart views only

Note. Greyed-out if the **Trace select** menu enable is not selected – see page 83.

Touch to hide individual channel traces to improve chart clarity.

Traces are identified by the Channel Number (for example, Channel 1.1) and its tag.

Note. The recording of a channel's data is not affected by this operation and the instantaneous channel values are still shown on the indicators at the top of the screen.



Chart Annotation





Chart views only

Note. Greyed-out if the **Chart annotation select** menu enable is not selected – see page 83.

If an alarm or operator message is obscuring part of a chart trace, use the Chart Annotation facility to hide or display alarms and messages on the screen. Select the annotation required. ✓ indicates the annotations selected.

Note.

- If more than 15 icons are present on the screen, chart annotation is disabled automatically.
- If chart annotation is disabled, new operator messages and alarms are still added to the Alarm Event log – see Section 4.6.1, page 34.

 Sign Chart <i>Chart views only</i>	Note. Available only if Security system is set to <i>Advanced</i> (see Section 7.7.5, page 74) and the user's access privileges include e-Sign (see page 78). Sign the chart electronically – see Section 4.8, page 48.
 Start Batch <i>Chart views only</i>	Touch to start batch recording for the displayed group – see Appendix E.3.3, page 178 for full details on the use of the batch recording function. Note. Greyed-out if batch recording has not been enabled during Group configuration and / or a batch is running.
 Stop Batch <i>Chart views only</i>	Touch to stop batch recording for the displayed group.
 Service <i>Chart, indicator, bargraph and overview display views only</i>	Touch to display the sub-menu.
 Instrument Status	Touch to display the Instrument Status screen, providing the following information: <i>Software version</i> – version of the software currently installed. <i>System version</i> – version of the recorder's operating system. <i>Serial number</i> – the serial number of the recorder. <i>Instrument tag</i> – recorder name as it appears in the recorder's archive files. <i>Archive time remaining</i> – estimated time remaining before the external archive media becomes full. <i>Archive Media</i> – the type of archive media inserted. <i>Operating time</i> – length of time the recorder has been operational. <i>IP or MAC Address</i> – internet or MAC address assigned to the recorder (display alternates between addresses). <i>Options enabled</i> – list of enabled software options. Blank if no options have been enabled.

 **Diagnostics Logic**

Note. Greyed-out if Math & Logic software option is not enabled.
Touch to display the sub-menu.

 *Logic Eqtn 1*
(to 8)

Touch relevant icon to diagnose the logic equation.

Note. Unconfigured logic equations are greyed-out.

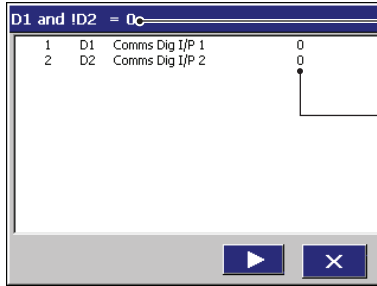

Calculation result

Values of individual equation elements

Touch  to run the equation and display its result based on current inputs.

Touch  to pause the calculation.

Touch  to exit.

 **Diagnostics Maths**

Note. Greyed-out if Math & Logic software option is not enabled.
Touch to display the sub-menu.

 *MathsBlock 1*
(to 9)

Touch relevant icon to diagnose the math block.

Note. Unconfigured math blocks are greyed-out.

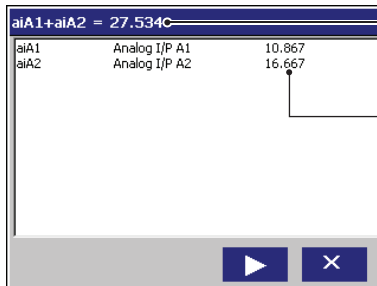

Calculation result

Values of individual math block elements

Touch  to run the calculation and display its result based on current inputs.

Touch  to pause the calculation.

Touch  to exit.



Input Adjust

Note. Displayed only if **Operator Calibrate** on one of the **Analog I/P** configuration tabs is set to *On* – see page 113.

Touch to manually fine-tune inputs to remove process offset errors or system scale errors for the selected input.

Note. All totalizer menu items are greyed-out if the totalizer software option is not enabled.



Totalizer Stop / Go

Indicator and overview display views only

Note. Greyed-out if the relevant **Totalizer stop / go** menu enable is not selected – see page 84.

Touch to stop and start individual totalizers.

Note. When a totalizer is not running (*Stop* has been selected), the corresponding totalizer value is shown in red.



Totalizer Reset

Indicator and overview display views only

Note. Greyed-out if the relevant **Totalizer reset** menu enable is not selected – see page 84.

Touch to reset the totalizer value to the totalizer preset value.



Show Statistics

Show Totalizers

Indicator and overview display views only

Note. Greyed-out if the **Show totalizers / statistics** menu enable is not selected – see page 84.

Touch **Show Statistics / Show Totalizers** to toggle between the totalizer value display and totalizer statistics display (totalizer maximum, minimum and average values).

If both totalizers on one channel are enabled and:

- *Show Totalizers* is selected – the tag, current value and units for both totalizers are displayed together in the channel's indicator.
- *Show Statistics* is selected – the tag, units, maximum, minimum and average values for each totalizer are displayed in turn for 5 seconds in the channel's indicator.



Show Totalizer Values

Show Channel Value

Indicator and overview display views only

Touch **Show Totalizer Values / Show Channel Value** to toggle between the totalizer value display and instantaneous channel value display.

Note. Greyed-out when more than 6 channels are displayed.



Max/Min Reset

Bargraph views only

Note. Greyed-out if the **Max / min reset** menu enable is not selected – see page 85.

Touch to reset the maximum and minimum value markers on one or all channels to the current value.

Note.

- These maximum and minimum values are for display purposes only. They are not saved or archived and are not connected to the totalizer maximum and minimum values displayed in the Indicator view.
- These maximum and minimum values are reset whenever the current configuration has been changed or is re-saved.





Filter Select

*Alarm Event and
Totalizer log views only*

Select the entries to be displayed in the log. ✓ Indicates entries selected.

Note.

- Hiding and displaying log entries does not affect the recording of events in the log.
- All selected alarm event transitions (from inactive to active, from active to acknowledged, from acknowledged to inactive, from active to inactive) appear in the sequence in which they occurred.
- Selecting *Active Transitions Only* displays entries for alarms when made active and hides all acknowledged and inactive transitions.
- To quickly select all entries, touch  followed by .

4.8 Electronic signatures

Entering an electronic signature is the equivalent to signing the chart of a conventional paper recorder. Local procedures may require the approval of a record by an authorized signatory; for this reason, an electronic signature is password protected.

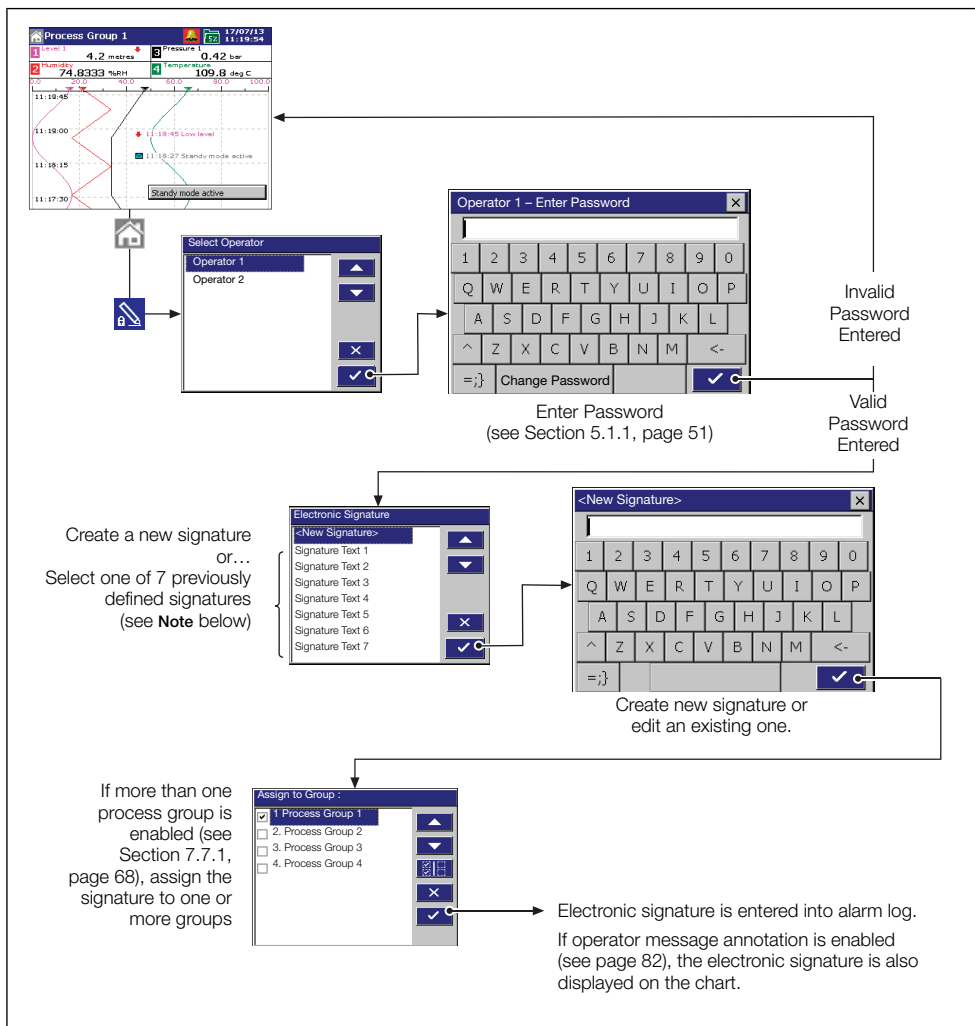

Fig. 4.12 Entering an electronic signature

Note. Up to 7 electronic signatures can be stored in the recorder's memory. If 7 signatures exist and a new one is created, the oldest is overwritten.

5 Logging

Logging enables the Operator to:

- Switch between primary and secondary sample rates
- Reset archiving
- Set the archive media card online and offline
- View internal and external archive media file directories and delete files from external archive media

5.1 Logging access

Access to Logging is controlled by the recorder's Security System.

- If Security System is set to *Basic* and Logging Security is set to *Off*, access to the Logging facility is unrestricted.
- If Security System is set to *Basic* and Logging Security is set to *On*, access to the Logging facility is protected by a single password for all users. Refer to Fig. 5.1 to access Logging.
- If Security System is set to *Advanced* and Logging Security is set to *On*, access to the Logging facility is protected by a unique password for each authorized user. Refer to Fig. 5.2, page 50 to access Logging.

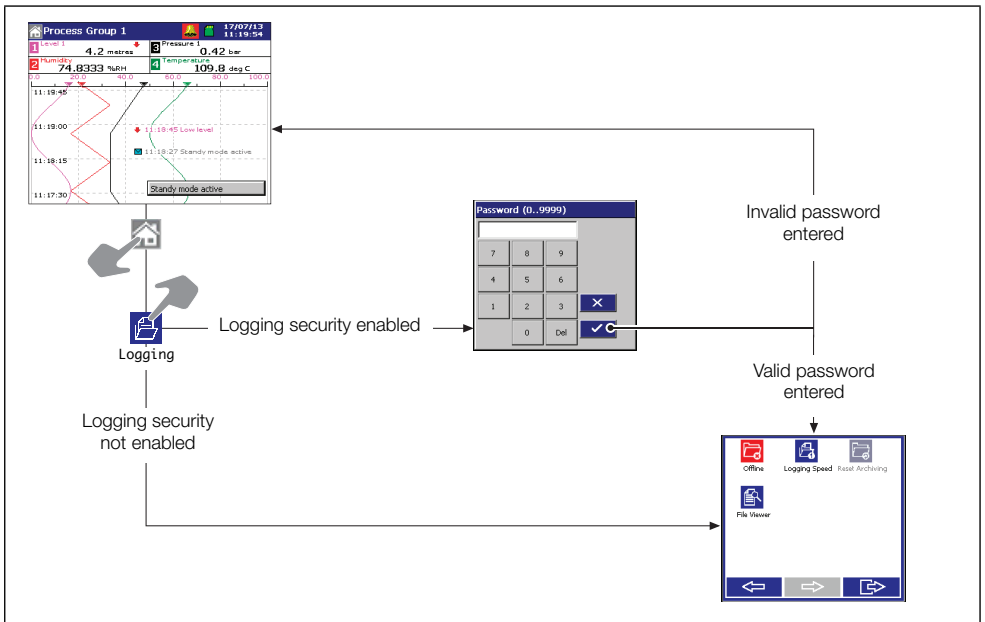

Fig. 5.1 Accessing logging – basic security

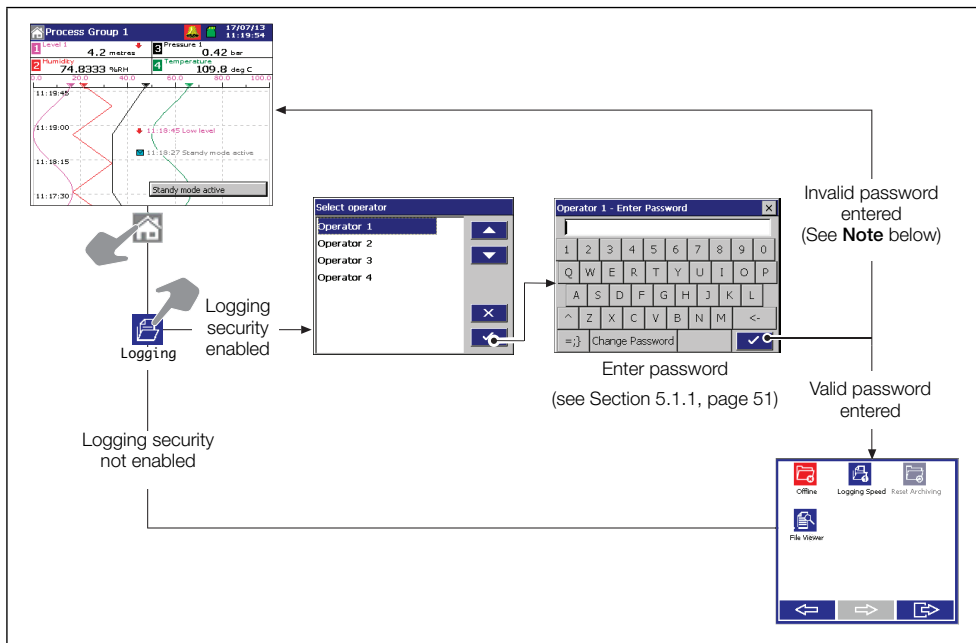

Fig. 5.2 Accessing logging – advanced security

Note. If an incorrect password is entered the display returns to the Operating view. However, if the maximum number of consecutive incorrect password entries is exceeded, the user's access privileges are removed and the following message is displayed:



If this occurs, access privileges can be reinstated only by the system administrator (User 1). If the system administrator's access privileges have been removed, the security system must be disabled using the internal configuration security switch to gain access to the configuration.

5.1.1 Password entry





Enter password

1. Enter the required password using the keyboard.
2. Touch  to complete password entry.



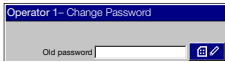

Change password

1. Touch **Change Password**.
2. Touch  to display the character entry keyboard.
3. Enter the old password using the keyboard and touch .
4. Enter the new password using the same procedure as for the old password.
5. Enter the new password again to confirm it.
6. Touch .

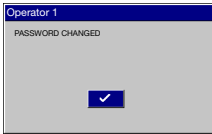

Password change successful.



Note. If  is touched at any stage before the new password is confirmed, the password change operation is cancelled and the following message is displayed:

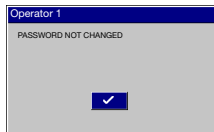

Password expired

Passwords can be configured to expire at pre-determined intervals. If a password is time expired, this screen is displayed automatically. Enter a new password as described above.

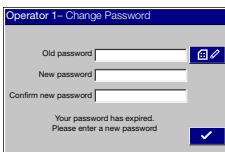

5.2 Logging menu



Touch to display the Operator menu.



Logging

Touch to display the sub-menu.



Online

Note. Greyed-out if no archive media is inserted or **Archive Media** is set to *None* (see Section 7.7.2, page 70) or the recorder has been placed in historical review mode (see page 40).

Logging is off-line. Touch to set logging on-line and start the archiving process.

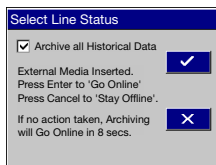

When external archive media is inserted, a dialog is displayed giving the User the option of setting logging on-line and starting the archiving process or remaining off-line. If no action is taken within 10 seconds, logging is set on-line and archiving is started automatically.

If the **Archive all Historical Data** checkbox is de-selected, older unarchived data remains in the internal memory buffer until overwritten by newer data but is not available for archiving unless 'Reset archiving' (see page 53) is selected.



Offline

Note. Greyed-out if the recorder has been placed in historical review mode.

Logging is on-line. Touch to set logging off-line and stop the archiving process.

Recording of channel data into internal memory continues uninterrupted but archiving to the selected storage media is suspended until logging is set on-line again.

Note.

- Always set logging off-line before changing the storage media type selection (see Section 7.7.2, page 70) or removing external media. A warning is displayed if the storage media type selection is changed or external media is removed before logging is set off-line.
- When logging is set off-line, an **Updating archiving** progress bar is displayed. Do not remove external media until archiving is complete. To stop archiving, touch **Stop Immediately**.



Logging Speed

Touch to toggle between the primary and secondary sample rates.

The primary sample rate is set typically to a relatively slow rate (depending upon process recording requirements) and is active during normal process operating conditions in order to maximize internal memory and external archive media.

The secondary sample rate is set typically to a faster rate than the primary rate and may be selected manually in order to record the maximum amount of detail during, for example, an alarm condition.

The rates are set during configuration – see page 81.

Note.

- Switching between the primary and secondary sample rates does not affect the screen interval in the Vertical and Horizontal Chart views.
- Recording can also be controlled using digital sources – see Sections 7.8.1 page 80 and 7.9.1 page 86.

Note. The Primary and Secondary icons (below) are greyed-out if recording has been stopped via a digital signal.



Primary

Touch to switch to recording at the primary sample rate set during configuration – see page 81.



Secondary

Touch to switch to recording at the secondary sample rate set during configuration – see page 81.





Reset Archiving

Touch to enable all data in the internal memory to be re-archived to the selected storage media.

Note.

- Greyed-out when logging is on-line.
- If archiving to external media, insert / connect suitable blank media before selecting this function.

To re-archive data:

1. If archiving to external media, insert / connect archive media with sufficient free space.
2. Ensure archiving is offline.
3. Touch  in the logging menu.
4. Touch  in the logging menu.



File Viewer

Touch to view a list of the files stored in internal flash memory or external archive media.

6 Archiving

6.1 Introduction

Recorded data, logs and configuration files stored in the recorder's internal memory can be archived in binary encoded format to:

- SD Card
- USB flash drive in either the front or rear USB ports
- Internal memory

Archiving is configured in the **Common configuration** level – see Section 7.7.2, page 70.

The following icons are displayed in the Status bar to indicate archiving status:

- Archive media online (green icon, number indicates % used)
Do not remove external media while online
- Archive media offline (grey icon)
- Archive media 100 % full, archiving stopped (green icon, flashing red cross)

The Instrument Status screen indicates the storage media type in use and displays the approximate amount of free space remaining, assuming the amount of data recorded remains the same.

Note. To avoid loss of archive data, **always** set logging off-line **before** changing the storage media type selection (see Section 7.7.2, page 70) or removing external archive media. Set logging off-line by touching in the Logging menu.

Caution. Electrostatic precautions for SD cards.

To avoid potential damage or corruption to data recorded on an SD card, take care when handling and storing the card. Do not expose the card to static electricity, electrical noise or magnetic fields. When handling the card take care not to touch any exposed metal contacts.

6.2 Sample rates

Data is saved to the archive file at the same rate as it is saved to internal memory, for example, at either the Group's primary or secondary recording sample rate.

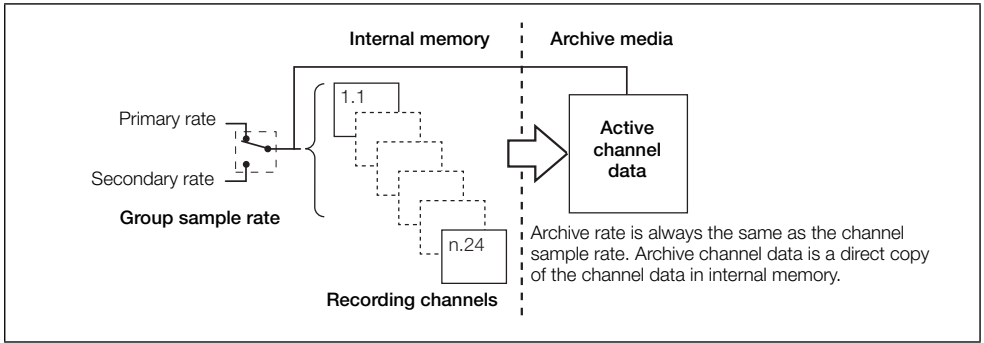

Fig. 6.1 Archiving sample rates

6.3 Archive file types

Archive files are created in secure binary encoded format.

All archive files created by the recorder are given filenames automatically. File types and extensions are shown in Table 6.1.

Type	Extension	No. of Files	Contents
Channel data files	*.DX0	One per channel	Analog or digital recording channel data.
Alarm Event log files	*.EX0	One per recorder	The historical record of the alarm events plus the history of any operator messages.
Totalizer log files	*.TX0	One per recorder	The historical record of all totalizer and associated statistical values.
Audit log files	*.AX0	One per recorder	The historical entries from the audit log.
Batch log files	*.BX0	One per process group	Batch information associated with a process group.

Table 6.1 File types and extensions

Note. Totalizer and batch files are created only if the respective totalizer and batch options are enabled.

6.4 Archive filenames

Examples of archive filenames are shown in Table 6.2.

Type	Format
Analog channel data files	<Start Date>_<Start Time>_<Serial Number>_Ch<Group>_<Channel>_Analogue000 For example, 20130516_160838_3K10000123456_CH1_02_Analogue0000.DXO
Digital channel data files	<Start Date>_<Start Time>_<Serial Number>_Ch<Group>_<Channel>_Analogue000 For example, 20130516_160838_3K10000123456_CH1_02_Digital0000.DXO
Alarm Event log files	<Start Date>_<Start Time>_<Serial Number>_alarm For example, 20130516_160838_3K10000123456_alarm.EXO
Totalizer log files	<Start Date>_<Start Time>_<Serial Number>_totalizer For example, 20130516_160838_3K10000123456_totalizer.TXO
Audit log files	<Start Date>_<Start Time>_<Serial Number>_audit For example, 20130516_160838_3K10000123456_audit.AXO
Batch log files	<Start Date>_<Start Time>_<Serial Number>_batch For example, 20130516_160838_3K10000123456_batch.EXO

Table 6.2 Archive filenames

6.5 Channel data file creation

A new channel data file is created under the following conditions:

- When the current file for a channel does not exist on the media card.
- When the maximum size (6 MB) of the existing data file is exceeded.

6.6 Log file creation

A new log file is created under the following conditions:

- When an existing valid log file does not exist on the media card.
- When the maximum size (6 MB) of the existing log file is exceeded.

6.7 Data file examples

Archived data is stored in a secure binary encoded format. A separate file is created for each recording channel. The log data is stored in an encrypted text format. The files can be read on a PC using the Company's DataManager Pro data analysis software package.

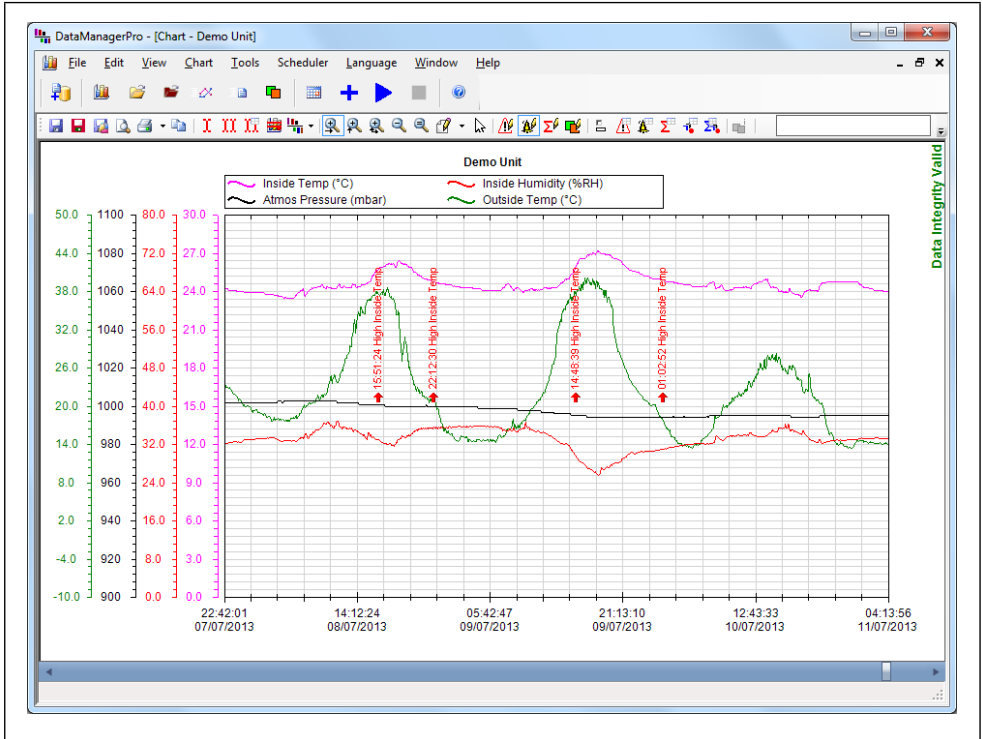

Fig. 6.2 DataManager Pro file sample

6.8 Data verification and integrity



When data is saved to the archive media it is checked automatically to verify that the data stored on the media matches exactly what is stored in the internal memory.

Each block of data in the channel data files has its own data integrity check. This enables the integrity of the data stored on the archive media to be verified when it is viewed using the Company's DataManager Pro software package.

The log files also contain built-in integrity checks enabling the integrity of the data to be verified by the DataManager Pro software.

6.9 Logging online / offline

Before data can be archived, the storage media and one or more group channel data file enables must be selected, the storage media inserted (if external) and logging set on-line.

- When external archive media is inserted, a dialog is displayed giving the User the option of placing the media on-line and starting the archiving process or remaining off-line. If no action is taken within 10 seconds, the media is placed on-line and archiving is started automatically.
- Logging is set on-line (if archive media is present) or off-line by touching  /  in the Logging operator menu for each Operator view.
- Always set logging off-line before changing the storage media type selection (see Section 7.7.2, page 70) or removing external media to prevent loss of data and possible damage to the media. A warning is displayed if the storage media type selection is changed or external media is removed before logging is set off-line

Note. Data stored in the internal memory buffer can still be transferred to the archive media when the archive media is placed on-line again (providing it is not off-line so long that the un-archived data in the internal memory is overwritten).

6.10 Backing-up archived data

It is advisable to back-up critical data stored on archive media on a regular basis. The recorder's internal memory provides a buffer for the most recent data so, if data stored on archive media is lost, it can be re-archived – see **Reset archiving**, page 53.

To ensure that all required data is available for re-archiving, it is recommended that data archived on archive media is removed and backed-up before the recorder's internal buffer overwrites that data. The length of time that data remains in the recorder's internal memory depends on the sample rate and the number of channels selected – see Table C.1, page 170 for details.

6.11 Archive wrap

Archiving can be configured to delete the oldest archived data file automatically from the archive media when the media approaches its maximum capacity – see **Wrap**, page 70.

7 Configuration

7.1 Introduction

This section describes how to access the recorder's **Configuration** level and make changes to the parameters using the operator keys.

7.2 Configuration level security

Two methods of configuration access protection are available:

1. **Password protection** (factory default).

The **Configuration** level cannot be accessed until the correct password has been entered – see Figs. 7.1 and 7.2, pages 60 and 61 respectively.

2. **Internal switch protection.**

The **Configuration** level cannot be accessed until the internal switch set to the 'Configuration level not protected' position – see Fig. 7.3, page 62.

Internal security switch setting (see Fig. 7.3)	Configuration security parameter setting	
	Password protected (Factory default)	Switch protected (Alternative)
Configuration level protected (Factory default)	Password access	No access
Configuration level not protected	Free access	Free access

Table 7.1 Configuration security modes

The recorder can be configured for one of two levels of password protection:

Basic security:

- Up to 4 users
- Each user is assigned a unique 4-digit security code for **Configuration** level access
- Optional security code protection of access to the logging facility

Advanced security:

- Up to 40 users
- Each user is assigned a unique password of up to 20 characters
- Each user is assigned configuration and / or logging access privileges
- Each user is assigned one of 3 levels of configuration level access privileges
- Configurable password expiry times, password failure limits and minimum password length
- Inactive user disabling

7.3 Configuration level access

To configure the recorder when Configuration security is set to the factory default setting of *Password protected*:

1. Access the **Configuration** level – see Figs. 7.1 and 7.2, pages 60 and 61 respectively.
2. Make changes to parameters as detailed in Figs 7.5 and 7.6 (pages 64 and 65 respectively).

To configure the recorder when Configuration security is set to *Internal switch protected*:

1. Set the internal security switch to the 'Configuration level not protected' position – see Fig. 7.3, page 62.
2. Access the **Configuration** level – see Figs. 7.1 and 7.2, pages 60 and 61 respectively.
3. Make changes to parameters as detailed in Figs 7.5 and 7.6 (pages 64 and 65 respectively).

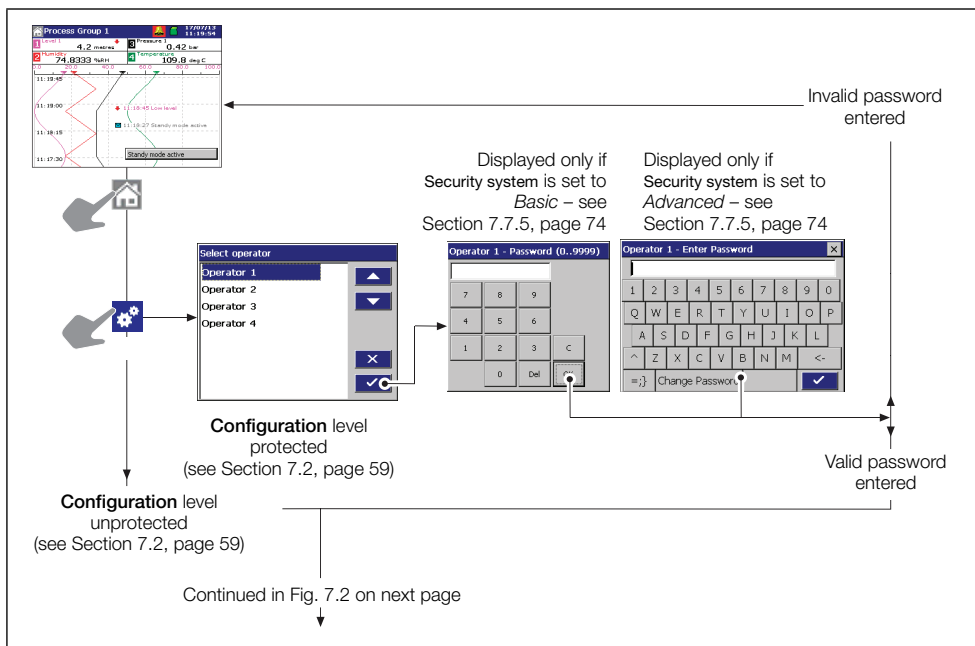

Fig. 7.1 Accessing the configuration level

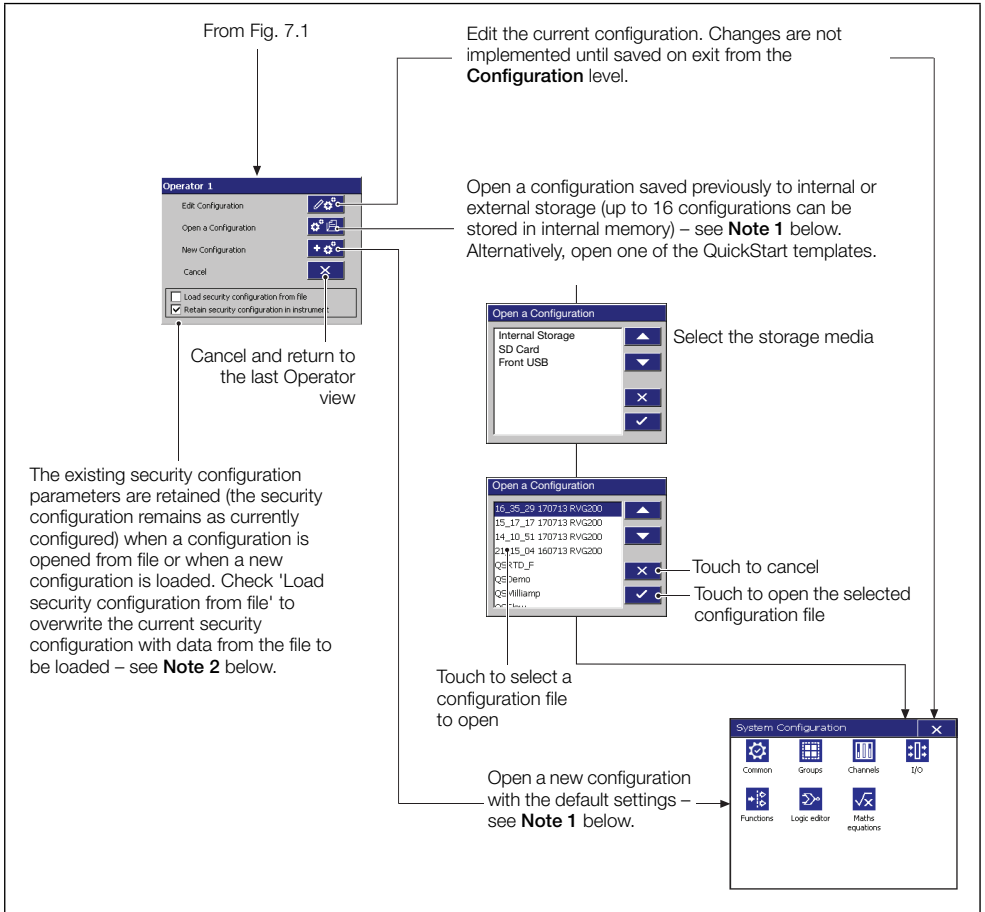

Fig. 7.2 Accessing the configuration level (continued)

Note.

1. If *New Configuration* or *Open a Configuration* is selected and the modified configuration file is saved later as the current configuration, new internal data files for all enabled recording channels are created and any unarchived data is lost.
2. The option to load or retain the security configuration applies only to Advanced Security mode and is available only to the System Administrator (User 1). If a new or existing configuration file is opened by a user other than the System Administrator, the recorder's existing security settings are retained.

Referring to Fig. 7.3, set the internal security switch as follows:

1. Isolate the recorder from the power supply.
2. Remove tamper-evident seal (A) (if fitted).
3. Unscrew jacking screw (B) securing the recorder to the case and remove the recorder from its case.
4. Set security switch (C) to the 'Configuration level not protected' position (toward the front of the recorder).

Note. The internal security switch is used to access the **Configuration** level when Configuration security is set to *Internal switch protected*. **Do Not** use the switch to access the **Configuration** level when Configuration security is set to *Password protected* (default setting) unless the password has been forgotten. The switch overrides password protection, enabling free access to the **Configuration** level.

5. Refit the recorder to its case and secure with jacking screw (B).
6. Refit tamper-evident seal (A) (if required).
7. Restore the power supply to the recorder.

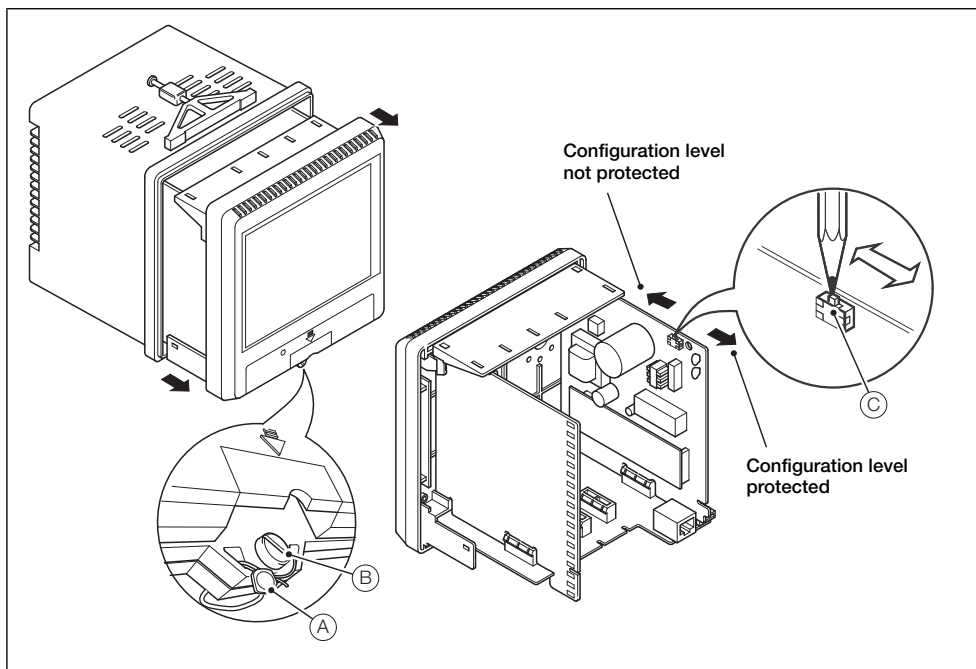

Fig. 7.3 Setting the security switch

7.4 Overview of configuration

Referring to Fig. 7.4, configure the recorder as follows:

- 1 Touch the required icon in the system configuration menu.

Note. Only enabled process groups (and their associated channel options) and enabled software options (for example, Math and Logic) are visible in the menu.

- 2 Touch the edit button to select and edit the required parameter(s).
- 3 Touch the next tab required and repeat step 2.
- 4 Repeat steps 2 and 3 as required.
- 5 When all changes are complete, touch **X** to return to the system configuration menu.
- 6 Touch the next configuration icon required and repeat steps 2 to 5.
- 7 When all configuration changes are complete, touch **X** to exit the **Configuration** level (refer to Section 7.6, page 66).

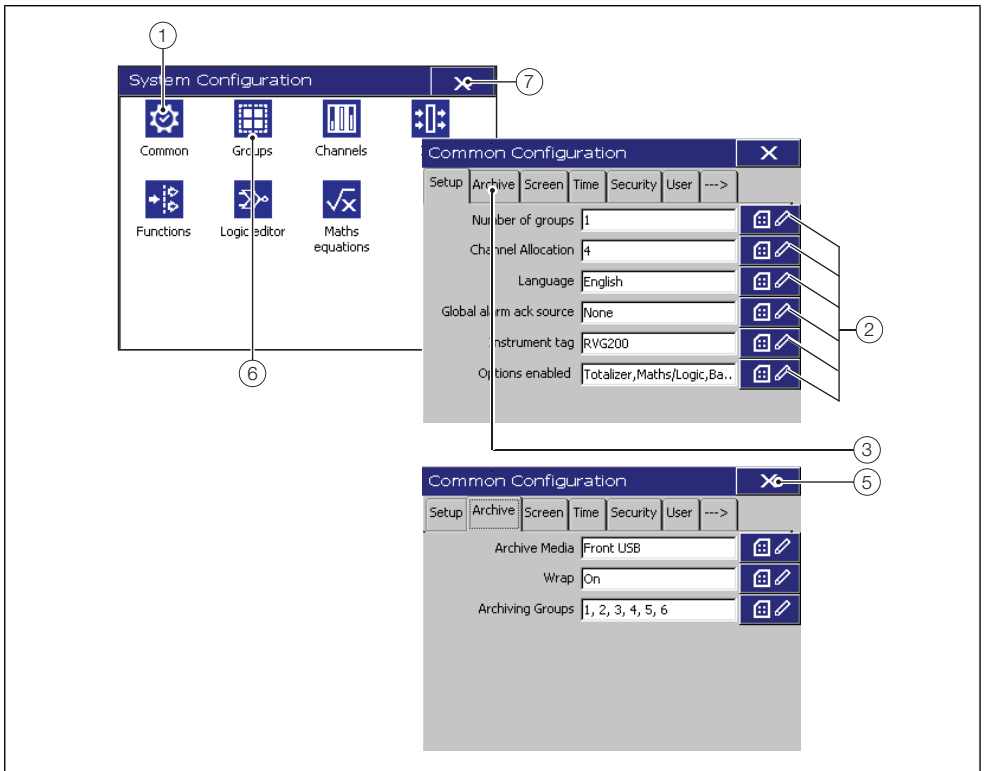

Fig. 7.4 Overview of configuration steps

7.5 Making changes to parameters

Referring to Fig. 7.5, parameters are located as follows:

- ① Configuration tab.
- ② Parameter.
- ③ Parameter value.
- ④ Edit button.
- ⑤ Sub-menu.
- ⑥ Higher-level windows remain visible to identify location within the configuration structure.
- ⑦ Selection list.
- ⑧ Touch an option or use ▲ and ▼ to select it. Touch ✓ to accept the selection.
- ⑨ Touch to close a menu.
- ⑩ Touch to go to next / previous channel.

Note. The appropriate data entry box is displayed automatically.

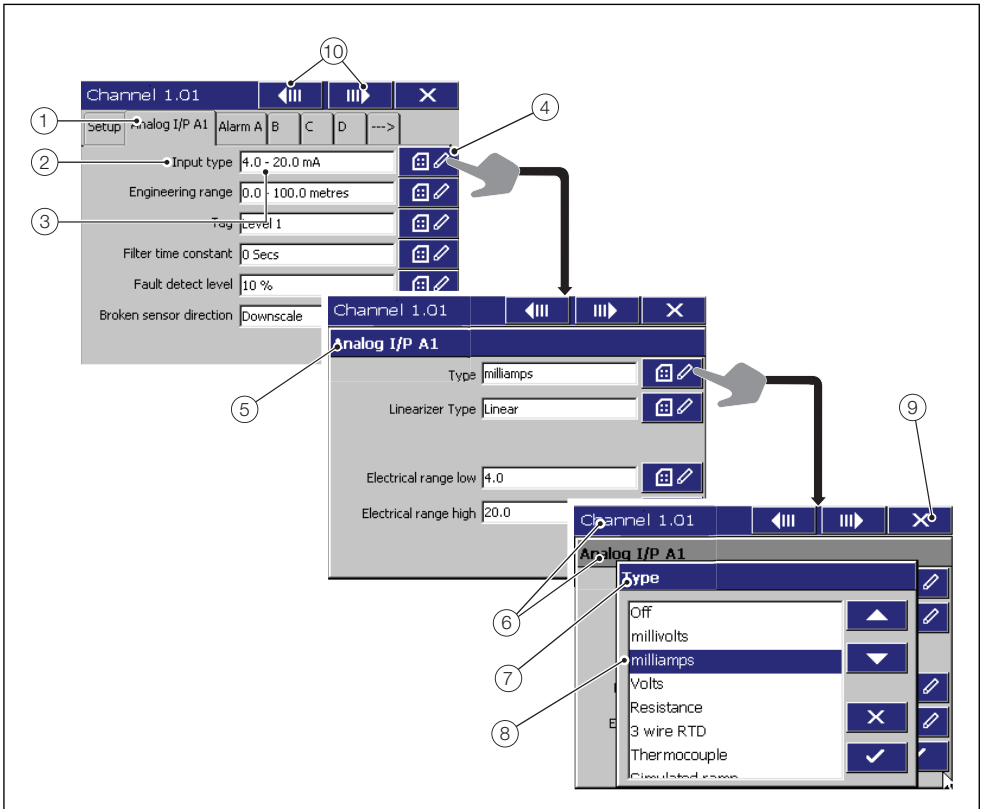

Fig. 7.5 Locating parameter settings

Referring to Fig. 7.6, use data entry dialog boxes as follows:

- ① Touch an item or use the ▲ and ▼ keys to select it.
- ② Items not selected are indicated by an 'X' in the parameter value window.
- ③ Parameter limits.
- ④ Values outside the preset parameter limits or with too many decimal places are highlighted when the OK button is touched
- ⑤ Cursor.
- ⑥ Touch the keypad / keyboard characters to enter them at the cursor position *.
- ⑦ Delete / backspace.
- ⑧ Spacebar.
- ⑨ Alternative characters – see Appendix F, page 180.
- ⑩ Shift key.

* Refer to Appendix F, page 180 for further information regarding character use.

Note. Tags with a high percentage of capital letters and wide characters such as 'W' or 'M' may appear truncated in some Operator views. To prevent this, use lower case letters or fewer characters.

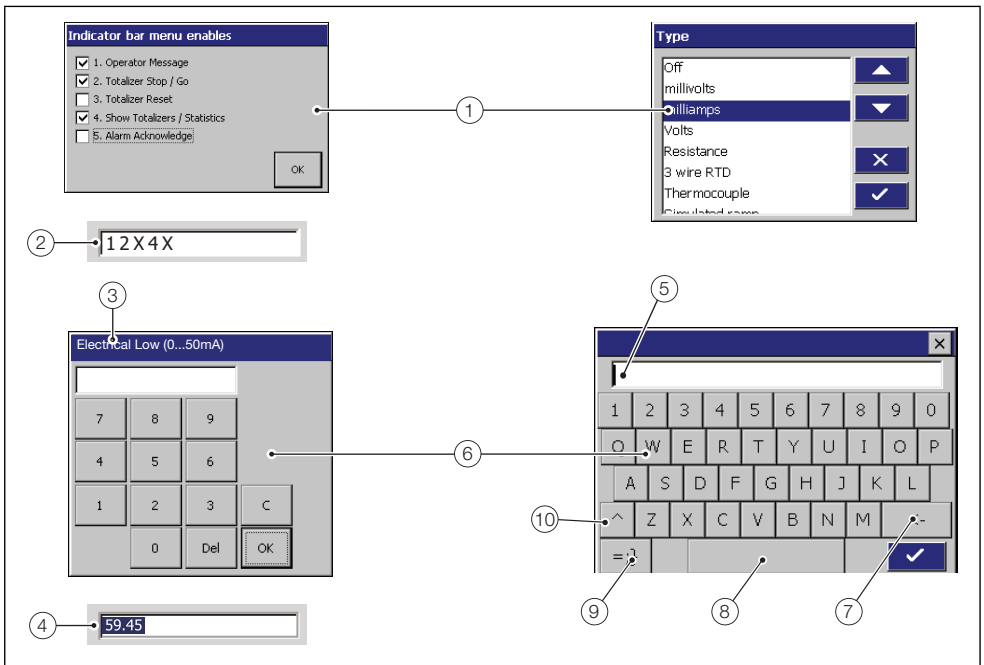

Fig. 7.6 Data entry dialog boxes

7.6 Exiting the configuration level

Referring to Fig. 7.7, exit the **Configuration** level as follows:

- ① From the main **System Configuration** menu, touch .
- ② To apply changes and begin using a configuration immediately, touch – see **Note 1** on page 67.
The configuration is saved to internal memory with the filename '<time> <date> <instrument tag>.cfg' and the recorder returns to the **Operating** level.
A warning is displayed if the configuration change will result in the creation of new data files. Touch to accept the changes or to reject them.
- ③ Touch to export the current configuration to selected storage media – see **Note 2** on page 67.
- ④ Touch to return to the **Configuration** level to continue configuring the recorder.
- ⑤ Touch to discard all changes and return to the **Operating** level.

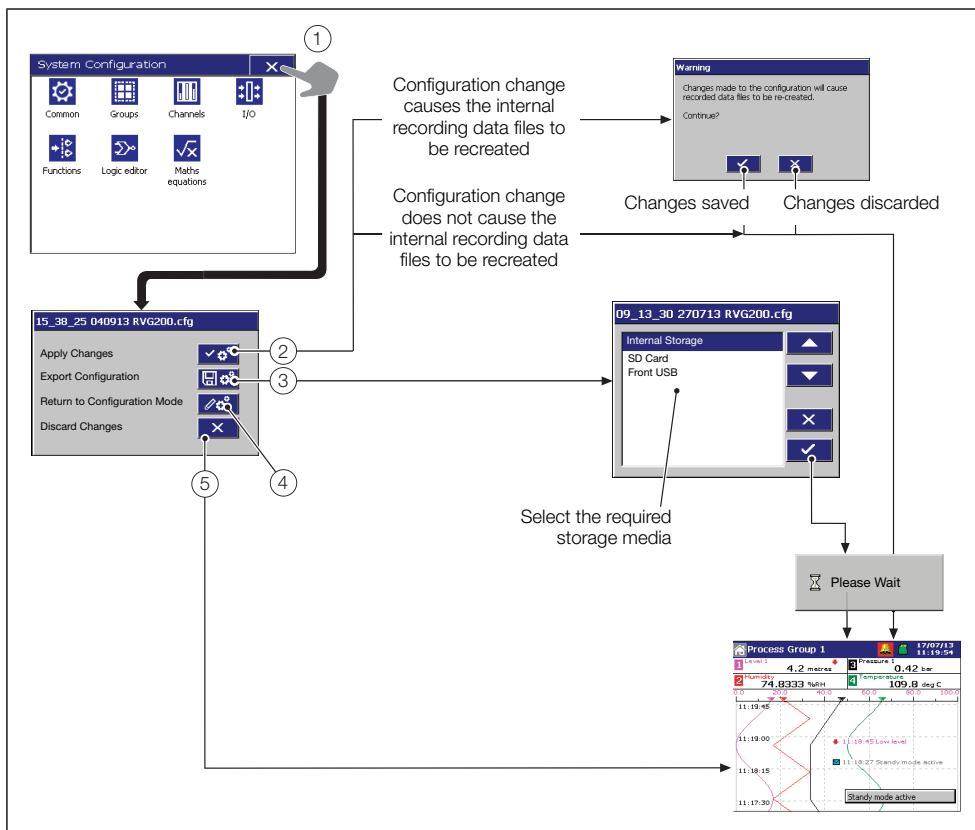



Fig. 7.7 Exiting configuration mode

Note. 1

- Changes are saved to persistent storage only when *Apply Changes* or *Export Configuration* is selected. Any powerdown before this results in lost configuration changes.
- If *Apply Changes* is selected, new internal data files for enabled recording channels are created if:
 - A recording channel source parameter is changed
 - The primary and / or secondary sample rates and / or their sources for either process group are changed.
 - The input filter type parameter for any channel is changed
 - the engineering range parameter for any channel is changed
 - A channel tag parameter is changed
 - The number of process groups is changed
 - A previously disabled channel is enabled
- Touching  suspends recording briefly while the new configuration is implemented.

Note. 2 If changes are made to the current configuration and *Export Configuration* is selected, the configuration file complete with changes is saved to the selected storage media but the recorder continues to use the current, unchanged configuration. To make an exported configuration the current configuration:

1. Access the **Configuration** level – see Section 7.3, page 60.
2. Open the saved configuration – see see Fig. 7.2, page 61.
3. Touch  to exit the **Configuration** level.

7.7 Common configuration

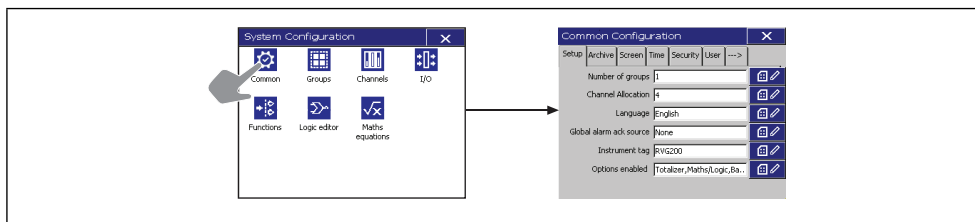

Fig. 7.8 Selecting common configuration

7.7.1 Setup

Setup

Number of groups *	Select the number of process groups required.
Channel Allocation *	Select the recording channels to assign to each group. Note. <ul style="list-style-type: none"> ■ Each recording channel can be assigned to one group only. ■ Channels can be assigned to groups in any order.
Language	Select the language to be used to display standard user prompts and menu items. Note. A new language selection does not take effect until the configuration is saved.
Global alarm ack source	Select a signal source used to acknowledge all active alarms in both Process Groups simultaneously. Refer to Appendix A, page 146 for a description of the available sources. Note. This signal is edge-triggered. A rising edge (inactive to active) or falling edge (active to inactive) triggers global alarm acknowledgement.

* If this parameter is changed, internally-recorded data files are recreated and unarchived data is lost.

Instrument tag *	<p>Enter the tag to be used to identify the recorder in configuration and audit log files.</p> <p>Refer to Appendix F, page 180 for further information regarding character use in tags.</p> <p>Note. When reviewing data, the instrument tag is used to identify the source of the data, therefore it is important to ensure that the instrument tag is unique to each recorder.</p>
Options enabled	<p>Displays the optional functionality (Totalizers and / or Math and Logic and / or Batch recording) enabled on the recorder.</p>

* If this parameter is changed, internally-recorded data files are recreated and unarchived data is lost.

7.7.2 Archiving

Archive

Archive Media Select the storage media for the archive data:

None

SD Card

Front USB

Rear USB

Internal Flash

Note. *SD Card* is selected by default.

Wrap When set to *On*, archive wrap deletes automatically the oldest archived data file from external archive media when the media approaches its maximum capacity.

When set to *Off*, archiving stops automatically when external archive media is full. No files are deleted.

Archiving Groups Select the process group(s) to archive.

7.7.3 Screen

Screen

Screen saver wait time	Select the waiting time between the last key touch and activation of the screen saver.
------------------------	--

Screen Capture	<p>When set to <i>Enabled</i>, the user can save an image of any Operator screen to external archive media by touching  on the relevant Operator view menu.</p> <p>Note.</p> <ul style="list-style-type: none">■ All images are saved to external archive media in a folder named 'BMP' within the 'VRD' folder.■ The images are saved even if archiving is set to <i>Offline</i>.■ If external archive media is not inserted, or is full, the screen capture facility is disabled automatically.
----------------	---

Brightness	Adjust screen brightness.
------------	---------------------------

Overview Display	When set to <i>Enabled</i> , an overview of all configured recording channels can be viewed on one screen – see Section 4.5.4, page 33.
------------------	---

Overview Alarm Ack.	When set to <i>Enabled</i> , the Operator can acknowledge alarms from the Overview display.
---------------------	---

Chart View Timer	When set to <i>Enabled</i> , the operator view reverts to the Chart view after the time selected has elapsed. If more than 1 group is enabled, the AutoGroup Scroll feature is initiated automatically.
------------------	--





Touchscreen Tips	When set to <i>Enabled</i> , navigation hints are displayed on the touchscreen for 3 seconds in the log views and historical review mode showing where to touch the screen to navigate the views. Touch the screen anywhere to display the hints.
------------------	---

7.7.4 Date and time

Time

Date and time	Set the date and time formats and set the current date and time using a dialog box.
---------------	---

Note.

- If daylight saving is required, enter the settings (see next page) **before** setting the time and date as the operation of the internal clock is affected by the daylight saving settings.
 - Changing the date and time causes the recording to be disabled until the **Configuration** level is exited.
 - Changes to the date and time are effective immediately  in the dialog box is touched. Touch  in the dialog box to exit date and time setup without saving changes. Touching  when exiting the **Configuration** level (see Fig. 7.7, page 66) **does not** reset the clock to its previous setting.
 - Setting an earlier date or time results in the loss of all data currently in the internal buffer memory past that date. Data archived to external media is unaffected. If an earlier time must be set, change the **Instrument Tag** (see page 69). This causes new archive files to be created and the duplicated hour of data is then saved to the new files.
 - Time changes due to automatic daylight saving do not affect the recorded data.
 - If the  status icon is displayed the clock battery must be replaced – contact the Company.
-

Daylight Saving - Enable Select the daylight saving method.

Note. Changes to daylight saving are effective immediately a method is selected. However, if  is touched when exiting the **Configuration** level (see Fig. 7.7, page 66), the last saved daylight saving settings are restored.

Off	Daylight saving is disabled.
Auto – USA	The start and end of the daylight saving period in the USA is calculated automatically. The clock is incremented automatically by 1 hour at 2:00am on the second Sunday in March and decremented automatically by 1 hour at 2:00am on the first Sunday in November.
Auto – Europe	The start and end of the daylight saving period in Central Europe is calculated automatically. The clock is incremented automatically by 1 hour at 2:00am on the last Sunday in March and decremented automatically by 1 hour at 2:00am on the last Sunday in October.
Auto – Custom	The start and end of the daylight saving period can be configured manually for regions that do not follow either the USA or Europe conventions. The clock is incremented automatically by 1 hour at the manually selected start time and decremented automatically by 1 hour at the manually selected end time.

Daylight Saving - Start If **Daylight Saving – Enable** is set to *Auto – USA* or *Auto – Europe*, the start and end times are set automatically and cannot be changed.

Daylight Saving - End If **Daylight Saving – Enable** is set to *Auto – Custom*, set the start and end of the daylight saving period.

7.7.5 Security

Note. User 1 is the System Administrator and is able to change the Security type and all other security parameters. Other users can change only the Logging security setting and only if Security system is set to *Basic*.

Security

Security type	Set the Security type.
Security system	Select <i>Basic</i> or <i>Advanced</i> security – see Section 7.2, page 59.
Configuration security	Set the method of access to the Configuration level. <ul style="list-style-type: none">■ If <i>Password protected</i> is selected, access is via the password set for the user – see Section 7.7.6, page 76.■ If <i>Switch protected</i> is selected, access to the Configuration level is prohibited for all users once the changes have been saved and made active. Access to the Configuration level is then achieved only by setting the internal security switch to the 'Configuration level not protected' position – see Fig. 7.3, page 62.
Security Options	Note. Displayed only if Security system is set to <i>Advanced</i> .
Logging security	When set to <i>On</i> , access to the Logging level is protected by each user's unique password.
Acknowledge security	When set to <i>On</i> , each user must enter their unique password in order to acknowledge alarms.
Logging security	Note. Displayed only if Security system is set to <i>Basic</i> . When set to <i>On</i> , access to the Logging level is protected by a single, 4-digit password for all users.
Logging password	Note. Displayed only if Security system is set to <i>Basic</i> and Logging security is set to <i>On</i> . Enter the password to be used by all users to access the Logging level.

Note. The following parameters:

- are displayed only if Security system is set to *Advanced*.
- can be changed only by the System Administrator (User 1).

Reconfigure preset	Passwords are entered initially by the System Administrator but, subsequently, any user can change their own password. When this parameter is set to Yes, each user must change their password after it is used for the first time following initial configuration – see also Section 7.7.6, page 76.
Password expiry	Enter the time period after which all passwords expire. After this period of time, all users must change their passwords.
Inactive user disabling	Enter the time period after which an inactive user's access privileges are de-activated. A user is considered inactive if their password has not been used. A user is de-activated by removal of their access privileges and can be re-activated only by the System Administrator (User 1).
Password failure limit	Enter the number of consecutive incorrect password entries allowed by a user. If the number of incorrect entries exceeds this limit, the user's access privileges are de-activated and can be reinstated only by the System Administrator (User 1).
Min password length	Passwords have a maximum length of 20 characters. Enter the minimum length required for all new passwords.

7.7.6 Users

Note.

- User 1 is the System Administrator and is able to change user names / access privileges and enter initial passwords for all other users.
- if **Security system** is set to *Basic* (see Section 7.7.5, page 74) other users (if enabled by User 1) can change their user name, password and access privileges.
- if **Security system** is set to *Advanced* (see Section 7.7.5, page 74), other users cannot change their user names and access privileges once set by User 1, but all users may change their own passwords.
- The following parameters are displayed only if **Security system** is set to *Basic* – see Section 7.7.5, page 74.

User

User 1	Enter a name and password for User 1. Note. User 1 only is able to access this parameter.
User 2 (to 4)	User 1 can enter names and associated passwords to enable up to 3 additional users access to the Configuration level. Note. If enabled by User 1, another user can access their associated parameter and change the Name , Password and Access settings. However, if Access is set to <i>Disabled</i> by that user and the configuration saved, only User 1 can restore that user's access privileges.
Name	Enter a name for the selected user.
Password	Enter an initial password for the selected user.
Access	Set access privileges for the selected user. <i>Enabled</i> – The selected user is able to access the Configuration level. <i>Disabled</i> – The selected user is unable to access the Configuration level. Note. When the method of access to the Configuration level is set to <i>Password protected</i> (see Section 7.7.5, page 74) and a user with Configuration level access privileges changes the recorder's configuration, the Name of the user is included in the audit log entry.

Note. The following parameters are displayed only if *Security system* is set to **Advanced** – see Section 7.7.5, page 74.

User 1 Name	Configure User 1 (System Administrator)
User 1 Access	Select <i>e-Sign, Logging, Batch</i> (see Appendix E, page 173) and <i>Alarm acknowledge</i> access privileges as required (see also page 78). Note. Full Configuration level access privileges for User 1 cannot be disabled.
User 1 Password	Enter a password for User 1.
View/Edit Other Users	The System Administrator (User 1) can view and / or change the user name, access privileges and password for any other user. Select the user to be viewed / edited.
User 2 (to 12) Name	Enter a name for the selected user.

User 2 (to 12) Access	Set access privileges for selected user.
<i>e-Sign</i>	– The selected user is able to enter an electronic signature.
<i>Logging</i>	– The selected user is able to access the Logging level.
<i>Batch</i>	– The selected user is able to start and stop batch recording – see Appendix E.2, page 174.
<i>Configuration (No access)</i>	– The selected user is unable to access the Configuration level.
<i>Configuration (Load)</i>	– The selected user is unable to make any configuration changes but can load preset configurations from external media.
<i>Configuration (Ltd)</i>	– The selected user is able to: <ul style="list-style-type: none">■ Change alarm trip points, hysteresis and time hysteresis settings.■ Make input adjustments for analog input boards.■ Load configurations from external media only.
<i>Configuration (Full)</i>	– The selected user is allowed full configuration access with the exception of access to the Security settings.
<i>Alarm acknowledge</i>	– The selected user is able to acknowledge alarms.

Note. The System Administrator (User 1) only is able to change the Security settings.

User 2 (to 40) Password	Enter an initial password for the selected user.
--------------------------------	--

Note. The user may subsequently change this password.

7.7.7 Operator messages

Op. Messages 1..6 (and 7 to 24)

Message 1 (to 6) Operator messages can be triggered via the Operator menus or a digital signal. The message is stored in the Alarm Event log and may also be annotated on the chart view.

Message tag Enter the message text – 20 characters maximum.
Refer to Appendix F, page 180 for further information regarding character use in tags.

Source ID Select a signal source used to trigger the operator message. Refer to Appendix A, page 146 for a description of the available sources.
Note. This signal is edge-triggered. A rising edge (inactive to active) or a falling edge (active to inactive) triggers the addition of the operator message to the Alarm Event log.

Assign to group Select the group(s) to which the message is to apply.

7.8 Process group configuration

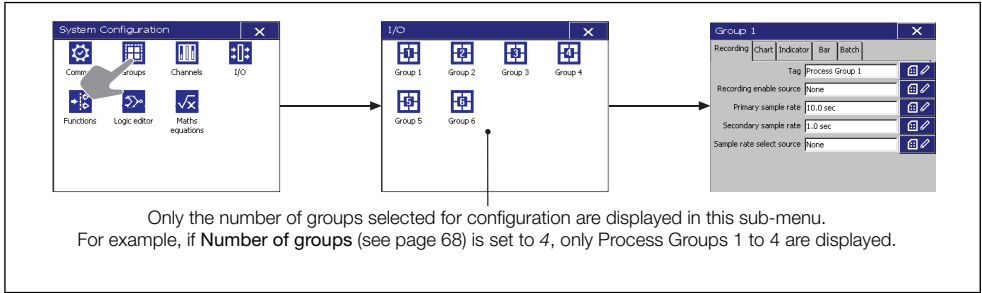

Fig. 7.9 Selecting process group configuration

7.8.1 Setting the recording parameters

Recording

Tag	<p>Enter a tag (maximum 20 characters) to identify the Process Group in the title bar when any Operator view from that group is displayed.</p> <p>Refer to Appendix F, page 180 for further information regarding character use in tags.</p> <p>Note. Each process group tag must be unique.</p>
Recording enable source	<p>Select a signal source to enable / disable recording of all channels in the current Process Group. Refer to Appendix A, page 146 for a description of the available sources.</p> <p>Note. This signal is edge-triggered. A rising edge (inactive to active) enables recording. A falling edge (active to inactive) disables recording.</p>



The recorder can be configured to sample all recording channels in the group simultaneously and store the data in internal memory and archive media (if archiving is enabled) at two rates, Primary and Secondary.

The Primary sample rate is active during normal process operating conditions and is set typically to a relatively slow rate (depending upon process recording requirements) in order to maximize internal memory and external archive media capacity.

The recorder can be configured to switch to a faster (Secondary) sample rate when a selected digital source becomes active in order to record the maximum amount of detail for the period in which that source is active; or it may be switched manually from the **Logging** operator menu – see Section 5.2, page 52.

Primary sample rate * Set to between 0.125 seconds and 60 minutes – Refer to Appendix C, page 170 for full details of internal memory and external archive media storage capacity.

Note.

- Sample rates are set using one of the following combinations of units:
 - Minutes or minutes and seconds
 - Seconds
 - 125^{ths} of seconds (*minutes and seconds must first be set to zero*).
- The rate at which data is displayed in the Chart views is set separately – see **Screen interval** on page 83.
- The fastest sample rate setting determines the maximum screen interval that can be selected – see Table 4.1, page 42.

Secondary sample rate * Set to between 0.125 seconds and 60 minutes.

Sample rate select source * Select a signal source to enable switching between the primary and secondary sample rates. Refer to Appendix A, page 146 for a description of the available sources.

Note. This signal is edge-triggered. A rising edge (inactive to active) switches to the secondary sample rate. A falling edge (active to inactive) switches to the primary sample rate.



* If this parameter is changed, internally-recorded data files are recreated and unarchived data is lost.

7.8.2 Configuring the chart view

Chart

Chart view enable	Select the Chart view required: <i>Off</i> – Chart view disabled <i>Vertical</i> – Chart runs from top to bottom <i>Horizontal --></i> – Chart runs left to right with scale bar on left <i>Horizontal <--</i> – Chart runs right to left with scale bar on right
-------------------	---

Chart Annotation	Select the annotations to be displayed on the chart. Alarm events and operator messages are displayed on the chart adjacent to the point at which the alarm occurred – see Section 4.5.1, page 28. This initial setting can be changed by the Operator if <i>Chart annotation select</i> is enabled in the Chart view menu enables – see Menu Enables , page 83.
------------------	--

Chart divisions	Enter the number of major and minor chart divisions to be displayed on the chart and its scale bar. Enter the number of major vertical divisions to be displayed. Enter the number of minor vertical divisions to appear between the major chart divisions.
-----------------	---

Pointers/Indicators	Enable trace pointers to display a chart scale bar with colored pointers to indicate the instantaneous trace positions.
---------------------	---



Disable trace pointers to display the standard chart scale bar.



Enable indicators to display the numbered channel indicators at the top of the screen.



Disable indicators to hide the indicators and enlarge the Chart view.

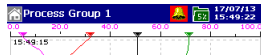

Screen interval	Select the amount of historical data to be displayed on the screen. Available selections are limited by the sample rate selected – see Section 7.8.1, page 80 and Table 4.1, page 42.
-----------------	---

Trace width	Select the required trace width in pixels.
-------------	--

Menu enables	Select the menu items to be accessible from the Chart view.
<i>Operator message</i>	– Enables the Operator to activate one of 24 pre-configured messages or a user-defined message.
<i>Alarm acknowledge</i>	– Enables the Operator to acknowledge any alarms associated with the current group.
<i>Scale select</i>	– Enables the Operator to display the scale for one enabled channel, or all channels in turn, on the scale bar at the top of the chart.
<i>Trace select</i>	– Enables individual chart traces to be displayed or hidden.
<i>Screen interval select</i>	– Enables the Operator to change the amount of data displayed on the screen at one time.
<i>Historical review</i>	– Enables the Operator to scroll back through data in internal memory that is no longer visible on the screen.
<i>Chart annotation select</i>	– Enables the display of alarm events and operator messages on the chart to be enabled or disabled by the Operator.

Note. Menu items that are not enabled are greyed-out in the relevant Chart View menu.

7.8.3 Configuring the indicator view

Indicator

Indicator	Select <i>On</i> to enable the Operator to display the Indicator view.
Totalizer / statistics	<p>Set to <i>On</i> to add the channel totalizer value and units to the Indicator view.</p> <p>Note. Available only if the totalizer option is enabled in the software and a totalizer for that channel is enabled.</p>
Bar graph display	<p>Set to <i>On</i> to add the Bargraph display to the Indicator view.</p> <p>Note. Bargraphs are displayed only for groups with a maximum of 6 recording channels.</p>
Alarm Trip Points	Set to <i>On</i> to add the alarm trip point indicators to the bargraphs.
Menu enables	<p>Select the menu items to be accessible from the Indicator view.</p> <ul style="list-style-type: none"> <i>Operator message</i> – Enables the Operator to activate one of 24 pre-configured messages or a user-defined message. <i>Totalizer stop / go</i> – Enables the Operator to start and stop the totalizers. <i>Totalizer reset</i> – Enables the Operator to reset the totalizer value to the preset totalizer value on any or all channels. <i>Show totalizers / statistics</i> – Enables the Operator to change the display to show either the totalizer values or the totalizer maximum, minimum and average values. <i>Alarm acknowledge</i> – Enables the Operator to acknowledge any alarms associated with the current group. <p>Note. Menu items that are not enabled are greyed-out in the Indicator view menu.</p>

7.8.4 Configuring the bargraph view

Bar

Bar graph view enable	Select <i>On</i> to enable the Operator to display the Bargraph view.
Bar graph markers	Select the markers to be displayed on the Bargraph: <i>No markers</i> <i>Max and min</i> <i>Alarm trips</i> <i>Max, min and alarm trips</i>
Menu enables	Select the menu items to be accessible from the Bargraph view. <i>Operator message</i> – Enables the Operator to activate one of 24 pre-configured messages or a user-defined message. <i>Alarm acknowledge</i> – Enables the Operator to acknowledge any alarms associated with the current group. <i>Max/min reset</i> – Enables the Operator to reset the maximum and minimum value markers on one or all channels to the current value. Note. Menu items that are not enabled are greyed-out in the Indicator View menu.

7.8.5 Batch recording

Refer to Appendix E, page 173.

7.9 Channel configuration

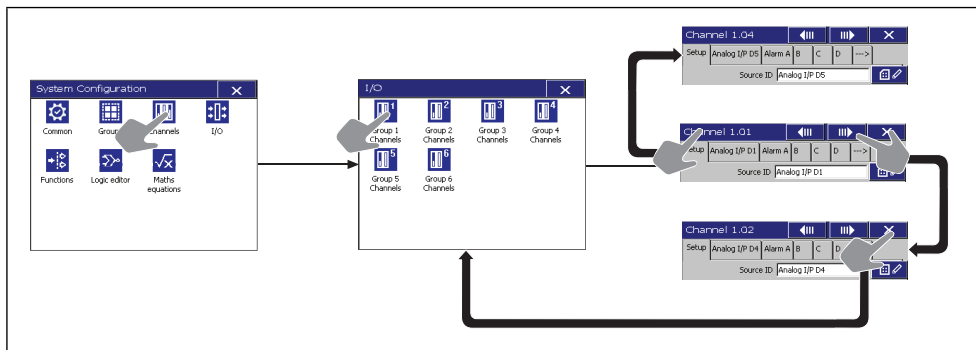

Fig. 7.10 Recording channel configuration

7.9.1 Recording channel setup

Setup

Source ID * Select the signal source for the selected channel. This can be any external analog or digital signal – see Appendix A, page 146 for full list.

Note.

- The tabs change according to the selection made.
- Setting a channel source to *None* does not switch off the analog input to which the channel was assigned previously (the analog input continues to be monitored). To switch off an analog input, set *Type* for the required channel to *Off* – see Section 7.9.2, page 90.

Trace color / Zone Select the color used to display the trace and its tag on Chart- and Indicator-views – 24 colors are available.

Each recording channel can be configured to position its trace in one of 9 specific zones in the Chart views in order to separate traces that would otherwise be very close to each other.

Select one of the pre-defined zones available if required.

* If this parameter is changed from any previous setting other than *None*, a new internal data file for this recording channel is created. All historical data stored internally for this channel is lost. If this parameter is changed from a previous setting of *None*, new internal data files for all enabled recording channels are created. Any unarchived data is lost.

Filter type *	Select the filter to be applied to the electrical input prior to sampling. Note. <ul style="list-style-type: none">■ Applicable to analog sources only.■ Filters are applied to the recorded values shown on the Chart view only, not to instantaneous values displayed on the channel indicators. <p><i>Instantaneous</i> – A single value based on process conditions at the time of sampling.</p> <p><i>Average</i> – The average value of the analog signal since the previous sample.</p> <p><i>Minimum</i> – The minimum value of the analog signal since the previous sample.</p> <p><i>Maximum</i> – The maximum value of the analog signal since the previous sample.</p> <p><i>Max & min</i> – Two values are recorded to capture the maximum and minimum signal values since the previous sample. This allows the memory use to be extended by permitting a slower sample rate to be selected without losing the transient behavior of the signal.</p>
---------------	--

* If this parameter is changed, internally-recorded data files are recreated and unarchived data is lost.

Scale type

Touch  to toggle between the type of scale displayed in the Chart view and the format of the current value readings displayed in the Chart-, Indicator-, Bargraph- and Overview Display-views.

Linear – normal linear scale displayed in the Chart view; normal current value readings displayed in the Chart-, Indicator-, Bargraph- and Overview Display-views.

Log – logarithmic scale displayed in the Chart view; current value readings displayed in exponential format. For example, $2.4E+4$ ($2.4 \times 10^{+4}$) is displayed in the Chart-, Indicator-, Bargraph- and Overview Display-views.

When set to *Log*, the Chart view's scale bar and graduations are displayed in logarithmic format with the input signal plotted linearly on the chart:

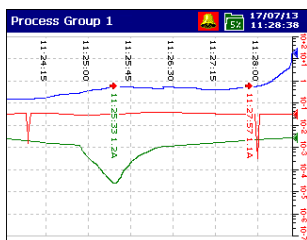

The recorded value in the Chart- and Indicator-views is driven by the engineering range selected and displayed in exponential format:

Chart view

 Level 1
3.2E+0 v

Indicator view

Level 1
1.8E+2
v 

Note. The following parameters are displayed only if **Scale type** is set to *Log*.

Low	Select the lower limit of the log decade range to be displayed on the Chart view scale.
-----	---

High	Select the upper limit of the log decade range to be displayed on the Chart view scale.
------	---

Numerical Display	Select the format in which the process value is to be displayed; <i>Exponential</i> – displays all values in the form $x.xE\pm y$ where x is any number from 0 to 9 (and 99 is out of range). <i>Standard</i> – display all values in exponential form as above, except those that fall within the low and high limits.
-------------------	---

Note. The following parameters are displayed only if **Numerical Display** is set to *Standard*.

Low Limit	Enter the low limit, in engineering units, below which values are displayed in exponential form.
-----------	--

High Limit	Enter the high limit, in engineering units, above which values are displayed in exponential form.
------------	---

7.9.2 Analog input configuration

Note.

- The **Analog I/P** tab is displayed only if **Source ID** for the Recording Channel is set to an analog signal source – see Section 7.9.1, page 86.
- If an analog input is assigned to more than one recording channel, changes to any of its parameters and tags are applied to each channel the input is assigned to.
- If an analog input is already assigned to another channel, the edit keys () are not available.

Analog I/P A1

Input type *	Select the electrical characteristics of the input.
Type	Select the input type required. Note. <ul style="list-style-type: none"> ■ Simulated input types are available for evaluating recorder features without the need for process connections. ■ If <i>Volt-free Digital Input</i> or <i>24V Digital Input</i> is selected, the input channel becomes a digital input channel – see Section 7.9.3, page 94. ■ Select <i>Off</i> to disable an analog input. <p>Warning. Ensure that the appropriate electrical connections have been made – see Section 3.3, page 14.</p>
Linearizer Type	Select the linearizer type used to condition the input signal before it is sampled. Note. For thermocouple applications using an external fixed cold junction, set Type to <i>millivolts</i> and select the appropriate linearizer type.
Linearizer units	Note. This parameter is displayed only if a temperature linearizer type (Thermocouple or RTD) is selected. Select the linearizer units used to condition the input signal before it is sampled.

* If this parameter is changed to or from *Volt-free Digital Input* or *24V Digital Input*, internally-recorded data files are recreated and unarchived data is lost.

ACJC Type

Note. This parameter is displayed only if *Type* has been set to **Thermocouple**.

Select the automatic cold junction compensation required:

- Per Module* – the recorder automatically detects an automatic cold junction device on another channel on the same module.
- Per Channel* – an automatic cold junction device must be fitted to the channel.
- External* – the automatic cold junction will be read from the configured analog signal.

Electrical range low
Electrical range high

Note. These parameters are displayed only if **Type** has been set to *millivolts, milliamps, Volts or Resistance*.

Set the required electrical range.

The range of the electrical input signal is determined by the input type – see Table 7.2:

Input type	Standard inputs			
	mV	V	mA	Ω
Minimum	-150	-10	0	0
Maximum	150	25	50	10000

Table 7.2 Limits of electrical ranges

Engineering range * Select the display characteristics of the input.

Low Specify the display range and units of the engineering value
 High corresponding to the electrical high and low values, within the limits
 Units ** defined in Table 7.3.

THC / RTD type	°C		°F	
	Minimum	Maximum	Minimum	Maximum
B	-18	1800	0	3270
E	-100	900	-140	1650
J	-100	900	-140	1650
K	-100	1300	-140	2350
L	-100	900	-140	1650
N	-200	1300	-325	2350
R & S	-18	1700	0	3090
T	-250	300	-400	570
Pt100	-200	600	-325	1100
Power 5/2 Power 3/2 Square Root Custom Linearizer 1 Custom Linearizer 2 Linear	-99999 to +999999			

Table 7.3 Limits of engineering ranges

* If this parameter is changed, internally-recorded data files are recreated and unarchived data is lost.

** Due to the display resolution, if more than 2 channels are assigned to a group, engineering units featuring a superscript 3 character (for example, m³) may not be displayed correctly in the Chart views.

Example – for an electrical input range of 4.0 to 20.0mA, representing a pressure range of 50 to 250 bar, set the Low value to 50.0 and the High value to 250.0.

Note.

- Select any of the engineering units pre-programmed into the recorder or select *Custom* and enter user-defined units (6 characters maximum). Refer to Appendix D, Table D.1, page 171 for a description of the pre-defined engineering units.
- The recorder can be configured to calculate the totalizer count rate automatically by ensuring that the engineering range unit of measurement selected for the channel to which the totalizer is assigned is a volumetric unit (quantity per unit of time, for example gallons per hour) – see page 103. If the recorder holds the relationship data between the selected measurement units and totalizer units, the count rate parameter is calculated and displayed automatically.

Tag *	Enter the tag name to be displayed in the Chart-, Bargraph-, and Indicator-views and used to identify the channel in archive files (20 characters maximum). Refer to Appendix F, page 180 for further information regarding character use in tags.
Filter time constant	Set the time period over which the process variable is to be filtered prior to being sampled (0 to 60 seconds).
Fault detect level	Set a tolerance level (between 0 and 100% of the engineering range) to allow for deviation of the input signal above or below the input span before an input failure is detected. Example – setting the fault detection level to 10% on an input range of 50 to 250 bar causes an analog input failure fault to be detected below 30 bar and above 270 bar.
Broken sensor direction	In the event of an input failure, recorder channels can be set to drive upscale, downscale or in the direction of failure. <i>None</i> – channel value driven in direction of failure. <i>Upscale</i> – channel value driven beyond full scale. <i>Downscale</i> – channel value driven below zero

* If this parameter is changed, internally-recorded data files are recreated and unarchived data is lost.

7.9.3 Digital input configuration

Note. The **Digital I/P** tab is displayed only if **Source ID** for the Recording Channel is set to a digital signal source – see Section 7.9.1, page 86.

Digital I/P A1

Input type *

Note. This parameter is displayed only if **Input type** on the **Analog I/P** tab (see page 90) is set to *Volt-free Digital Input* or *24V Digital Input*. If this parameter is changed to anything other than *Volt-free Digital Input* or *24V Digital Input*, the input channel reverts to an analog input channel – see page 90.

Digital on tag

Enter the tag to be displayed on channel indicators when the digital signal is active (6 characters maximum).

Refer to Appendix F, page 180 for further information regarding character use in tags.

Digital off tag

Enter the tag to be displayed on channel indicators when the digital signal is inactive (6 characters maximum).

Refer to Appendix F, page 180 for further information regarding character use in tags.

Tag

Enter the tag name to be displayed in the Chart-, Bargraph- and Indicator-views and used to identify the channel in archive files (16 characters maximum).

Refer to Appendix F, page 180 for further information regarding character use in tags.

* If this parameter is changed to or from *Volt-free Digital Input* or *24V Digital Input*, internally-recorded data files are recreated and unarchived data is lost.

7.9.4 Alarm configuration

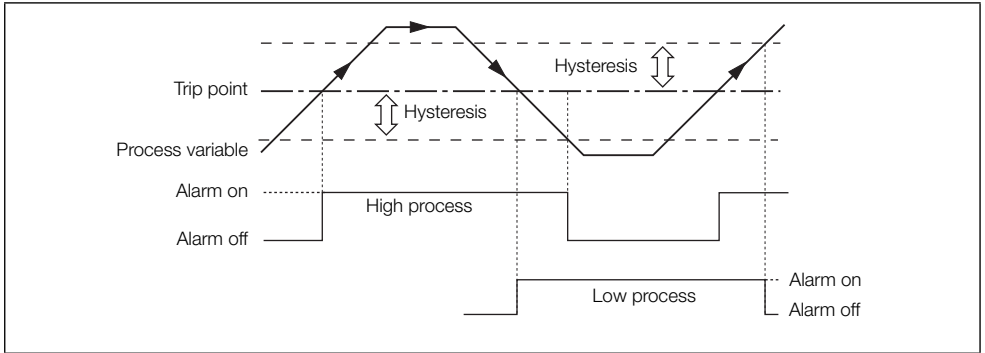

Fig. 7.11 High / Low process alarms

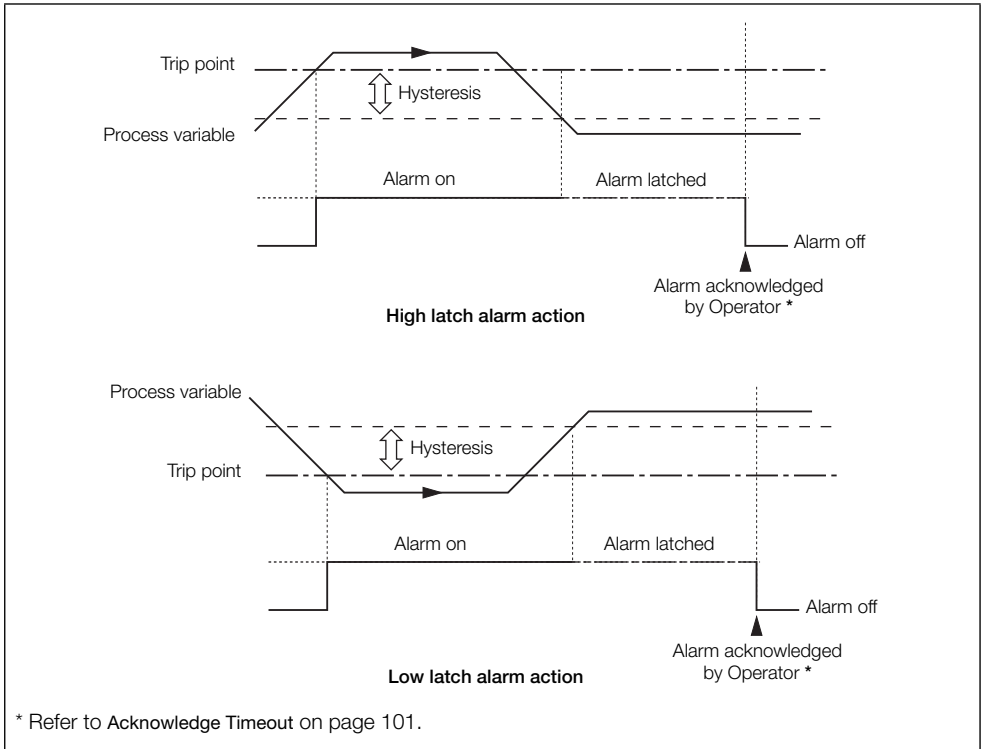

Fig. 7.12 High / Low latch alarms

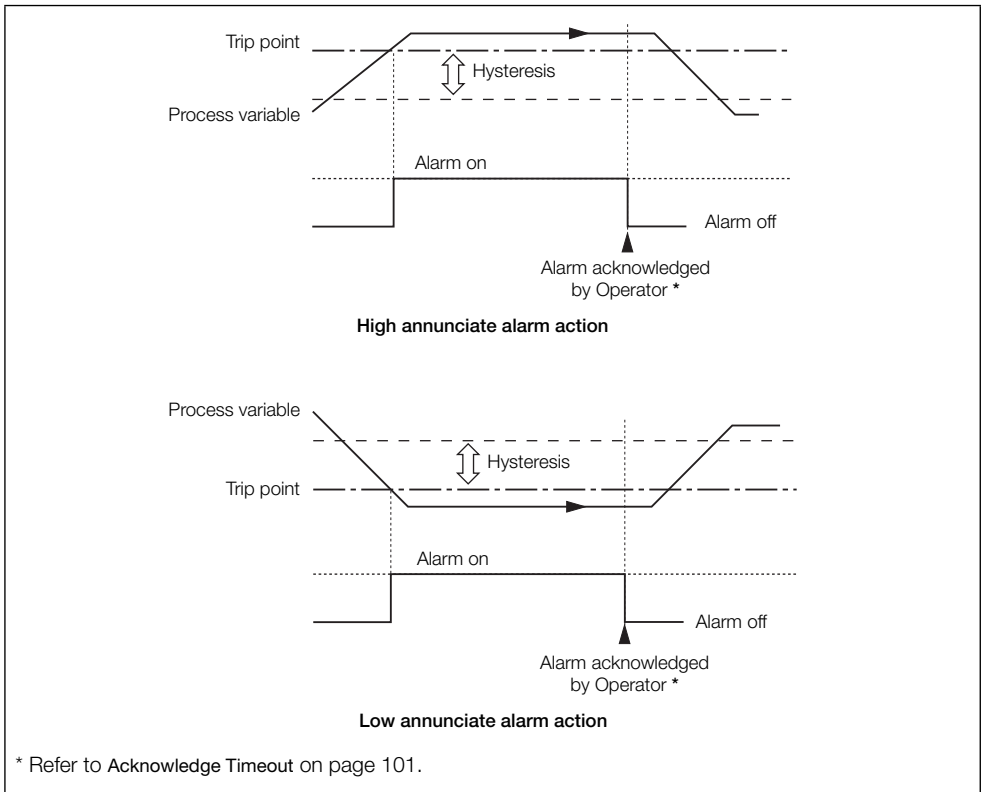

Fig. 7.13 High / Low annunciate alarms

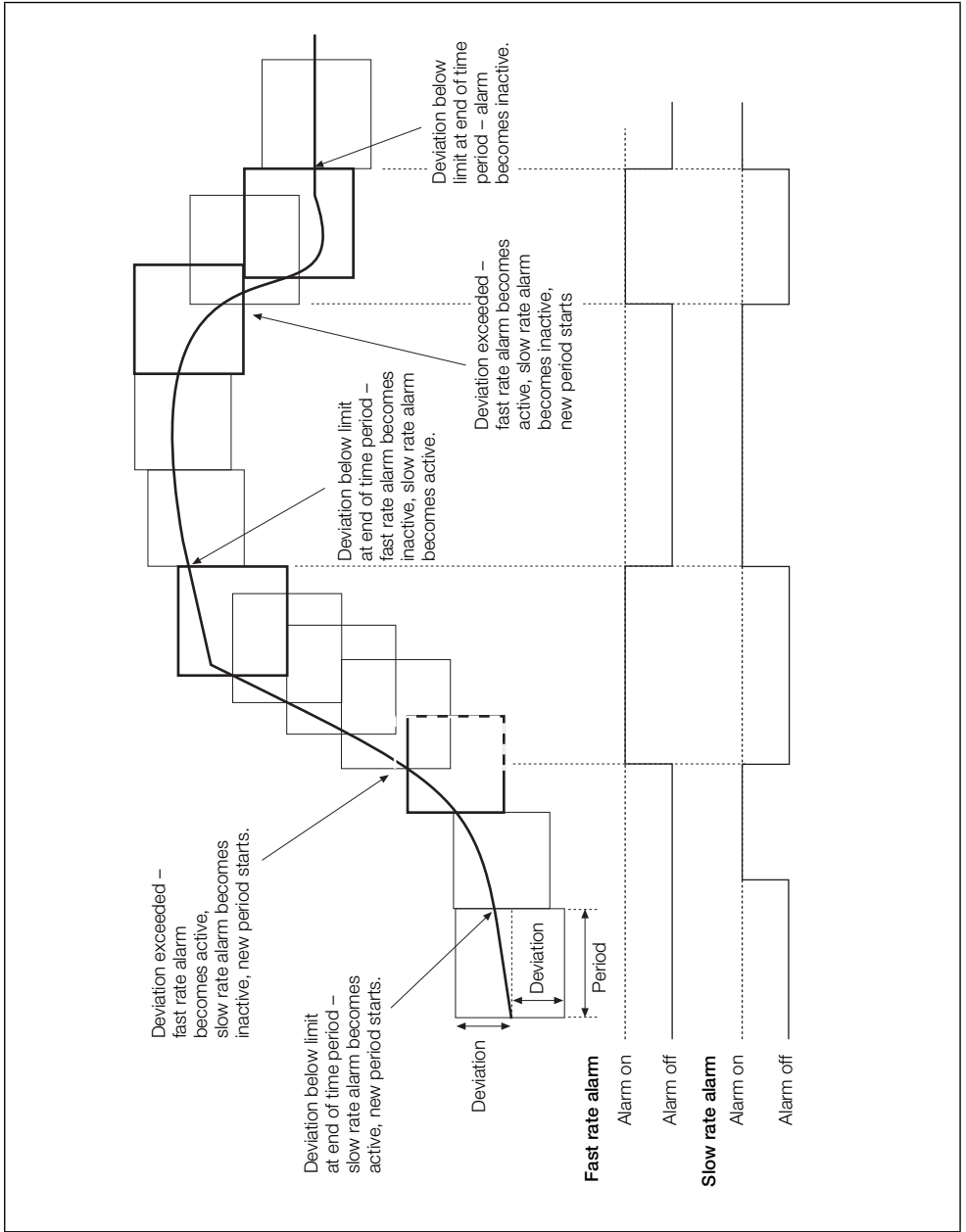

Fig. 7.14 Fast / Slow rate alarms

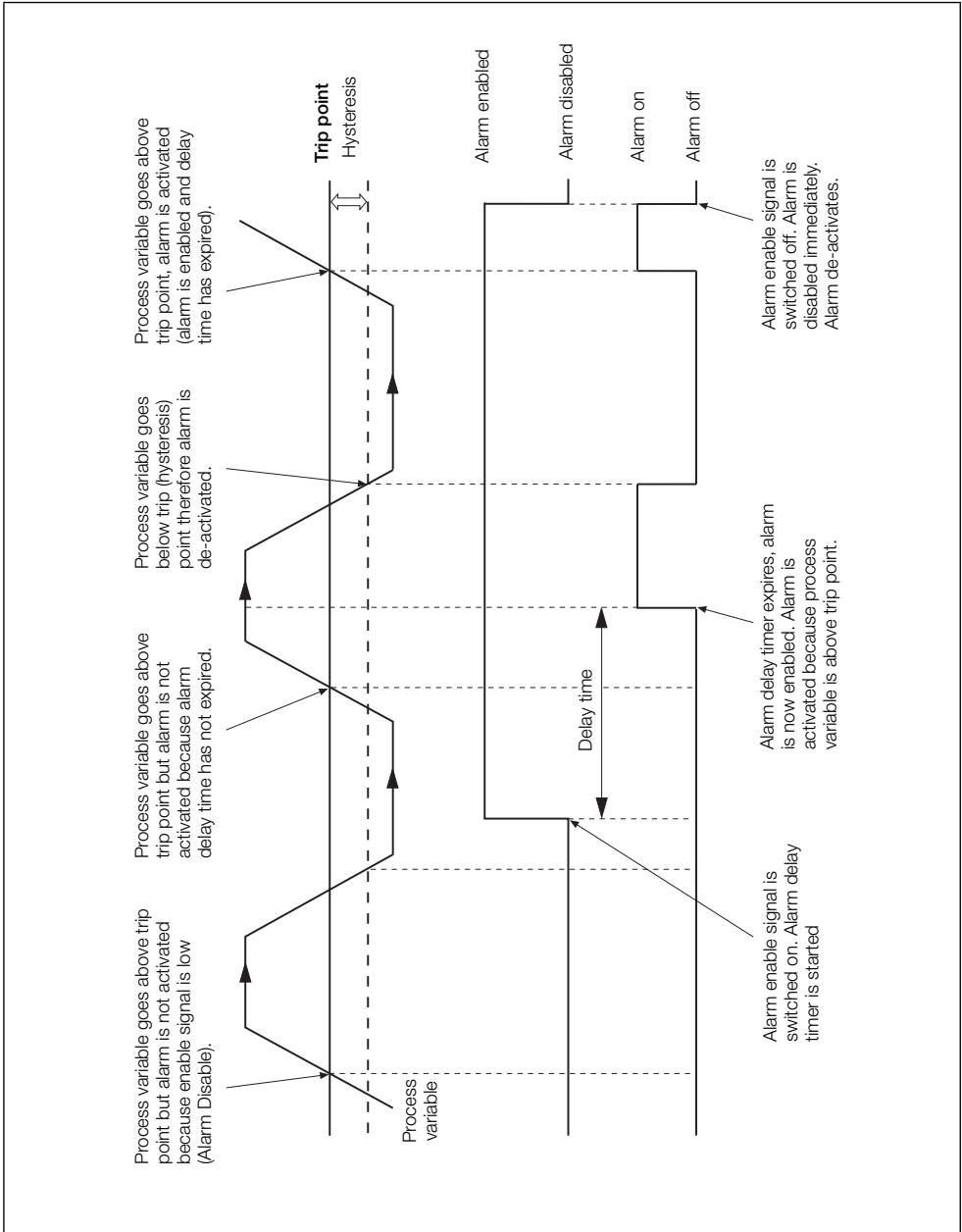

Fig. 7.15 Delayed high / low process alarms

Note. The **Alarm** tabs are displayed only if **Source ID** for the Recording Channel is set to an analog signal source – see Section 7.9.1, page 86.

Alarm A

Alarm type	Set the alarm type: <i>High / Low process</i> – see Fig. 7.11, page 95 <i>High / Low latch</i> – see Fig. 7.12, page 95 <i>High / Low annunciate</i> – see Fig. 7.13, page 96 <i>Fast / Slow rate</i> – see Fig. 7.14, page 97 <i>Delayed high / low process</i> – see Fig. 7.15, page 98
------------	--

Alarm tag	Enter an Alarm Tag to identify the alarm when it is displayed in the Chart views (if Chart Annotation is enabled – see pages 43 and 83) and Alarm Event log (20 characters maximum). Refer to Appendix F, page 180 for further information regarding character use in tags.
-----------	--

Note. The following parameters are applicable to process, latch and annunciate alarms only – see Figs. 7.11 and 7.12, page 95 and Fig. 7.13, page 96.

Trip	Set the value, in engineering units, at which the alarm is to activate.
------	---

Hysteresis *

Hysteresis *	Set the hysteresis value in engineering units.
Time hysteresis	Set the time hysteresis in seconds. When an alarm trip value is exceeded, the alarm does not become active until the time hysteresis value has expired. If the signal goes out of the alarm condition before the time hysteresis has expired, the hysteresis value is reset.

* Not applicable to annunciate alarms.

Note. The following parameters are applicable to delayed process alarms only – see Fig. 7.15, page 98.

Trip	Set the value, in engineering units, at which the alarm is to activate.
------	---

Hysteresis/Delay time

Hysteresis	Set the hysteresis value in engineering units.
------------	--

Delay time	Set the delay time in seconds.
------------	--------------------------------

The delay time is the period of time for which alarm activation is delayed after the enable signal is switched on. Once the delay time has expired, the alarm operates in the same way as a standard high / low process alarm.

Note. The following parameters are applicable to rate alarms only – see Fig. 7.14, page 97.

Deviation/Period	Note. A Rate alarm remains active until the rate has been within limits for at least one complete Alarm Period.
------------------	--

Deviation	Set the minimum or maximum amount of deviation allowed within the Rate Alarm Period before the alarm is activated.
-----------	--

Period	Set the time period over which the deviation is measured. For High Rate alarms, the alarm becomes active if the value changes by more than the deviation value within the alarm period. For Low Rate alarms, the alarm becomes active if the channel value changes by less than the deviation within the alarm period.
--------	--

Rate filter	Set the filter time to be used to reduce the number of spurious alarm trips. The signal source is averaged over the filter period prior to the rate alarm being determined.
-------------	---

Note. The remaining parameters are applicable to all alarms.

Enable source Select an alarm enable source. When the source is active, the alarm is enabled. When the source is inactive the alarm is disabled. If set to *None* the alarm is always enabled.

Note. An enable source must always be configured if it is to be used with a delayed process alarm – see Fig. 7.15, page 98.

Log Enable/Ack Timeout

Log Enable Set to *On* to record all changes in the alarm state in the Alarm Event log – see Section 4.6.1, page 34.

Acknowledge Timeout Set to *On* to enable an alarm acknowledgement timeout period that can then be set to between 1 and 999 minutes.

If the alarm is acknowledged but the alarm condition is not cleared within the time-out period, the acknowledge state reverts back to active and unacknowledged.

Note. The **Acknowledge Timeout** function is designed to prevent an alarm from being acknowledged but the reason for the occurrence being ignored.

Example. An application has a vital requirement for a product to be kept below a certain temperature (the alarm setpoint) and the recorder's alarm relay is connected to an external audible warning device. If the temperature exceeds the alarm setpoint, the alarm is activated, triggering the audible warning. To preserve accountability, the alarm can be acknowledged only by an Operator with alarm acknowledgement privileges (see Section 7.7.6, page 76) and if acknowledged, the audible warning is silenced. If the temperature does not drop below the alarm setpoint before the time-out period expires, the alarm state is reset to active / unacknowledged and the audible warning sounds again.

Alarm group Assign the alarm to one or more of 12 groups.

The alarm states assigned to each group are 'ORed' together to create an internal digital signal that may be assigned to relays, digital outputs or internal digital controls.

7.9.5 Totalizer configuration

Note.

- The totalizer tabs are displayed only if the Totalizer option is enabled.
- Current totalizer values are displayed in the Indicator view – see Section 4.5.2, page 31 (Operation) and Section 7.8.3, page 84 (Configuration), respectively.
- For analog sources, the total value of a signal is calculated by counting pulses produced at a rate proportional to the input. For digital sources, off / on transitions are counted to produce a batch total.

Totalizer A (B)

Setup

Mode

Select the totalizer operation mode:

Off

Standard (9 digits)

Standard (7 digits)

F₀

Timer (digital totalizers only).

Direction

Note. Displayed only if **Mode** is set to *Standard (9 digits)*, *Standard (7 digits)* or *Timer (digital totalizers only)*.

When **Direction** is set to *Up*, the totalizer counts up from the **Preset** count value to the **Predetermined** count value – see page 104.

Wrap enable

If **Wrap enable** is set to *On*, the total is reset automatically to the **Preset** count value once the **Predetermined** count value is reached.

If **Wrap enable** is set to *Off*, the count stops when the **Predetermined** count value is reached.

Note. A wrap pulse, with a duration of 2 seconds, occurs if the total reaches the **Predetermined** count value and **Wrap enable** is set to *On*. If **Wrap enable** is set to *Off*, the wrap pulse becomes active when the **Predetermined** count value is reached and remains active until the totalizer is reset. The pulse can be assigned to a relay, digital output or digital counter.

Tag/Units	
Tag	Enter the totalizer tag to be displayed in the Indicator view and the Totalizer log (6 characters maximum). Refer to Appendix F, page 180 for further information regarding character use in tags.
Units	Select any of the totalizer units pre-programmed into the recorder or select <i>Custom</i> and enter user-defined units (6 characters maximum). Refer to Appendix D, Table D.2, page 172 for a description of the pre-defined totalizer units. Note. The recorder can be configured to calculate the totalizer count rate automatically by ensuring that the engineering range unit of measurement selected for the channel to which the totalizer is assigned is a volumetric unit (quantity per unit of time, for example, gallons per hour) – see page 92. If the recorder holds the relationship data between the selected engineering range unit of measurement (see page 92) and the selected totalizer units, the totalizer count rate (see page 106) is calculated and displayed automatically.
Stop/Go/Reset	Select the totalizer action following a power failure and a digital signal to stop and start the totalizer:
Stop/Go recovery	<i>Last</i> – on power recovery, the totalizer continues in the same state as before the failure, either stopped or running. <i>Stop</i> – totalizer stops counting. <i>Go</i> – totalizer starts counting from the last recorded value.
Stop/Go source	Select a signal source to stop and start the totalizer; Refer to Appendix A, page 146 for a description of the available sources. Note. This signal is edge-triggered. A rising edge (inactive to active) starts the totalizer. A falling edge (active to inactive) stops the totalizer.  <p>The diagram shows two signal transitions. The first is a rising edge, where the signal level goes from low to high, with an upward-pointing arrow and the word 'Start' above it. The second is a falling edge, where the signal level goes from high to low, with a downward-pointing arrow and the word 'Stop' below it.</p>
Reset source	Select a signal source (see Appendix A, page 146) – an edge-triggered signal to reset the totalizer on a rising edge.
Timed Reset	Set the days and time at which the totalizer is reset.

Count range

Preset count Set the value the totalizer counts from and the value applied when the totalizer is reset.

Predetermined count Set the value at which the totalizer stops or wraps.

Note.

- A counter configured to count up must have a **Preset count** value lower than the **Predetermined count** value. A counter configured to count down must have a **Preset count** value greater than the **Predetermined count** value.
- Set the required number of decimal places on the higher of the **Preset count** value or **Predetermined count** value.

Intermediate count Set the value at which a digital source is activated (for example, this can be used as an alarm threshold to indicate when the **Predetermined count** value is about to be reached).

Log update

Log update time

Select the frequency with which totalizer values are added to the Totalizer log.

Log update time	Log updated every...
5, 10, 15, 30, 60, 90 secs	5, 10, 15, 30... seconds past the hour
3 min	0, 3, 6, 9... minutes past the hour
5 min	0, 5, 10, 15... minutes past the hour
10 min	0, 10, 20, 30... minutes past the hour
15 min	0, 15, 30, 45 minutes past the hour
20 min	0, 20, 40 minutes past the hour
30 min	0, 30 minutes past the hour
60 min	On the hour
2 hrs	Midnight, 2am, 4am,...
3 hrs	Midnight, 3am, 6am,...
4 hrs	Midnight, 4am, 8am,...
8 hrs	Midnight, 8am, 4pm,...
12 hrs	Midnight, 12am
24 hrs	Midnight

Log update source

Select a signal source (see Appendix A, page 146) – an edge-triggered signal to trigger the addition of the current totalizer values to the Totalizer log on a rising edge.

Note. The following parameters are applicable only to analog totalizers.

Count rate/Cut off

Set the required totalizer count rate (if necessary) and cut off value.

Count rate

Note. If the recorder holds the relationship data between the selected engineering range unit of measurement (see page 92) and the selected totalizer units (see page 103), the totalizer count rate is calculated and displayed automatically.

The count rate is determined by the maximum number of engineering units (or pulses) per second and the smallest totalizer increment:

$$\frac{\text{engineering full scale value (rate)}}{\text{engineering units (in seconds)}}$$

Example – to totalize a flow with a maximum rate of 2500 liters / minute (= 2.5m³ / minute) to the nearest 0.1m³, the calculation is as follows:

$$\frac{150\text{m}^3/\text{hour}}{3600 \text{ seconds}} = 0.04167 \text{ pulses/second}$$

The resulting value must be within the range 0.00001 to 99.99999. The totalizer increment is determined by the number of decimal places in the **Predetermined count value** – see page 104.

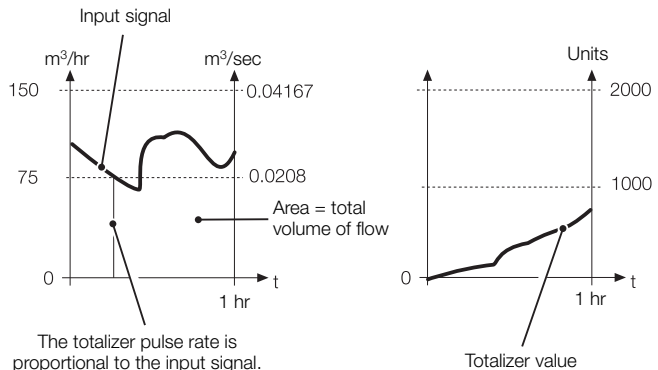

The totalizer pulse rate is proportional to the input signal. At this point it is 0.0208 pulses per second.

Cut off

Set the required totalizer cut off value – the lowest input value (in engineering units) at which the totalizer is to stop counting.

Note. The following parameter is applicable only to digital totalizers.

Count rate

Set the required totalizer count rate.

A digital totalizer pulse can be scaled to represent a value of between 0.00001 and 1000.00000. The totalizer is then incremented by this amount each time there is an off / on transition.

Example – a count of 5 digital pulses with **Count rate** set to 100 increments the totalizer from 0 to 500 in 100 unit steps.

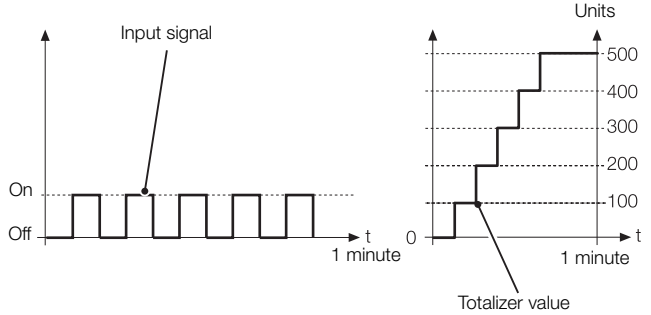

7.9.6 F₀ (sterilization optimization) configuration

Note.

- The totalizer tabs are displayed only if the totalizer option is enabled.
- F₀ configuration is applicable only to analog totalizers.
- Current F₀ values are displayed in the Indicator view – see Section 4.5.2, page 31 (Operation) and Section 7.8.3, page 84 (Configuration), respectively.
- Only totalizer A on all recording channels can be configured to display an F₀ value. If totalizer A is configured to display an F₀ value, totalizer B on the same channel is disabled automatically.

Calculation

The recorder's F₀ standard sterilization calculation is based on Ft @ T of 121.1 °C and Z of 10 °C where Ft = equivalent sterilization time of the sterilization procedure under temperature (T) conditions with a given Z value.

The recorder also adjusts Ft to compensate for changes in temperature in order to achieve a constant sterilization affect. The value used is D; a time value with a default setting of 1 minute.

The F₀ algorithm used by the recorder is:

$$F_0 = (\text{SampleTime} \times (10^{((T - 121.11)/Z)})) / (60 + F_0^{\text{previous}})$$

The result of the F₀ calculation is displayed in minutes in the Digital Indicator view (see Fig. 4.6, page 31) and in the Totalizer log (see Fig. 4.10, page 35).

Totalizer A

Setup

Mode Set to F₀.

Wrap enable

If **Wrap enable** is set to *On*, the total is reset automatically to the **Preset** count value once the **Predetermined** count value is reached.

If **Wrap enable** is set to *Off*, the count stops when the **Predetermined** count value is reached.

Note. A wrap pulse, with a duration of 2 seconds, occurs if the total reaches the **Predetermined** count value and **Wrap enable** is set to *On*. If **Wrap enable** is set to *Off*, the wrap pulse becomes active when the **Predetermined** count value is reached and remains active until the F₀ value is reset. The pulse can be assigned to a relay, digital output or digital counter.

<p>Tag</p>	<p>Enter the F_0 tag to be displayed in the Indicator view and the Totalizer log (6 characters maximum).</p> <p>Refer to Appendix F, page 180 for further information regarding character use in tags.</p> <p>Note. The default tag text includes 'F0' to distinguish an F_0 value in the Totalizer log but this can be changed.</p>
<p>Stop/Go/Reset</p>	<p>Select the action following a power failure and a digital signal to stop and start the F_0 value calculation:</p>
<p>Stop/Go recovery</p>	<p><i>Last</i> – on power recovery, the F_0 value calculation continues in the same state as before the failure, either stopped or running.</p>
	<p><i>Stop</i> – F_0 value calculation stops.</p>
	<p><i>Go</i> – F_0 value calculation continues from the last recorded value.</p>
<p>Stop/Go source</p>	<p>Select a signal source to stop and start the F_0 value calculation; Refer to Appendix A, page 146 for a description of the available sources.</p> <p>Note. This signal is edge-triggered. A rising edge (inactive to active) starts the calculation. A falling edge (active to inactive) stops the calculation.</p>
	 <p>The diagram shows two signal transitions. The first is a rising edge, where a horizontal line goes from a low level to a high level, with an upward-pointing arrow labeled 'Start' above it. The second is a falling edge, where a horizontal line goes from a high level to a low level, with a downward-pointing arrow labeled 'Stop' below it.</p>
<p>Reset source</p>	<p>Select a signal source (see Appendix A, page 146) – an edge-triggered signal to reset the calculation on a rising edge.</p>
<p>Target Temp/Z Value</p>	<p>Default values for the target temperature and Z factor are pre-configured but can be changed.</p>
<p>Target Temperature</p>	<p>Enter the required target temperature.</p>
<p>Z Value</p>	<p>Enter the required Z value.</p>

Count range

Preset count Set the value the F_0 value calculation counts from and the value applied when the F_0 count is reset.

Predetermined count Set the value at which the F_0 count stops or wraps.

Note.

- The **Preset count** value must be lower than the **Predetermined count** value.
- Set the required number of decimal places on the **Predetermined count** value.

Intermediate count Set the value at which a digital source is activated. This can be used as an alarm threshold to indicate when the **Predetermined count** value is about to be reached.

Log update

Log update time Select the frequency with which F_0 values are added to the Totalizer log.

Log update time	Log updated every...
5, 10, 15, 30, 60, 90 secs	5, 10, 15, 30... seconds past the hour
3 min	0, 3, 6, 9... minutes past the hour
5 min	0, 5, 10, 15... minutes past the hour
10 min	0, 10, 20, 30,... minutes past the hour
15 min	0, 15, 30, 45 minutes past the hour
20 min	0, 20, 40 minutes past the hour
30 min	0, 30 minutes past the hour
60 min	On the hour
2 hrs	Midnight, 2am, 4am,...
3 hrs	Midnight, 3am, 6am,...
4 hrs	Midnight, 4am, 8am,...
8 hrs	Midnight, 8am, 4pm,...
12 hrs	Midnight, 12am
24 hrs	Midnight

Log update source

Select a signal source (see Appendix A, page 146) – an edge-triggered signal to trigger the addition of the current F_0 values to the Totalizer log on a rising edge.

Cut off

Set the required F_0 cut off value.
The cut off value is the minimum temperature value (T) used in the F_0 value calculation. Temperatures read below this value are ignored.

7.10 I/O module configuration

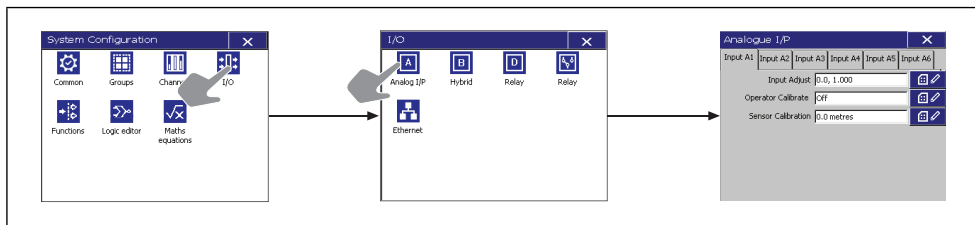

Fig. 7.16 I/O module configuration

Note. The recorder detects the type of module fitted in each position automatically.

7.10.1 Analog inputs

Input A1 (to D6)

Manually fine-tune inputs to remove errors.

Note. If the analog input type is changed (see page 90), the configuration must be saved to the current configuration before commencing input adjustment.

2 methods of input calibration are provided:

- Input adjust** – provides offset and span adjustment to remove process or system scale errors.
- Sensor calibration** – provides an offset adjustment to remove known sensor errors.



Input Adjust

Actual value
Desired value

1. Adjust the process or simulated input signal to a known value below 50% of the engineering range.
2. If Actual Value (in engineering units) is different from expected, set Desired value to the correct value (Offset adjust and Span adjust values are calculated automatically).
3. Repeat steps 1 and 2 for a value above 50% of the engineering range.
4. Repeat steps 1 to 3 for each input.

Reset adjustment Press  to reset Offset adjust and Span adjust (below) to zero and 1 respectively.

Offset adjust Manually fine-tune the offset adjust and span adjust values to remove process errors. These are calculated values applied to the raw input signal.

Span adjust

Note. If simulating thermocouple inputs, connect a millivolt source using appropriate compensating cable – see Table 3.1, page 18. For 2-lead resistance thermometers, either connect a resistance box at the sensor end of the leads or add the lead resistance to the calibration values.

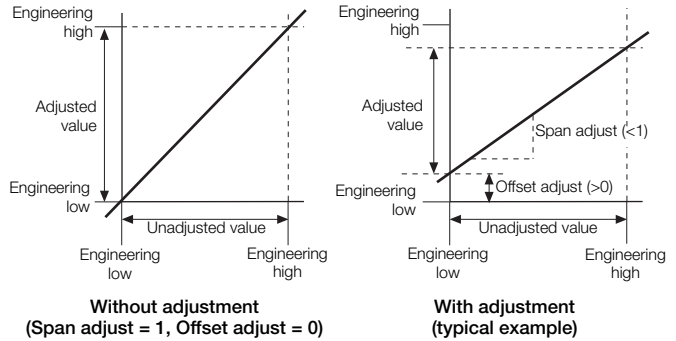

Operator Calibrate Set to On to enable input adjustment from the **Service** menu – see page 44.

Sensor Calibration An additional adjustment to remove known sensor errors.

Note. This adjustment is applied after the input calibration.

Adjusted Value The input value with the sensor calibration applied.

Offset adjust Enter the required offset in engineering units.

7.10.2 Relay modules

Relay A1(to D6)

Source

Select the relay source (a digital source) to be used to energize / de-energize the relay.

Note. If the relay is used to provide a totalizer count pulse, the maximum pulse frequency is 4 Hz. Consideration must also be given to the mechanical life of the relay.

Polarity

Select the relay source polarity.

Note. When polarity is set to *Positive*, the relay is energized when the digital source is active (On).

7.10.3 Hybrid modules

Output C1(to D6)

Output Mode Select the output mode required – *Analog*, *Digital* or *TxPSU*.

Note. The following parameter is displayed only if **Output Mode** is set to *Analog* or *Digital*.

Source Select the output source required.

An analog output source is the internal analog signal used to generate the analog output signal.

A digital output source is the internal digital source used to activate / de-activate a digital output.

Note. If a digital output is used to provide a totalizer count pulse, the maximum pulse frequency is 1 Hz.

Note. The following parameters are displayed only if **Output Mode** is set to *Analog*.

Engineering low Set the required analog output engineering range.

Engineering high **Note.** These settings are the engineering values corresponding to the Electrical low and Electrical high values below.

Electrical low Set the required analog output electrical range.

Electrical high These values are the minimum and maximum values of the current output, in electrical units – range 0 to 23 mA.

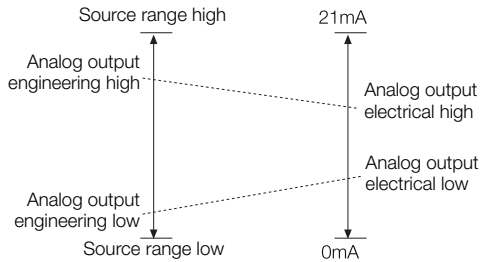

Note. The following parameter is displayed only if **Output Mode** is set to *Digital*.

Polarity Select the digital output source polarity.

Note. When set to *Positive*, the digital output is energized when the digital source is active (On).

Dgtl IP 1...5

Polarity

Select the digital input polarity to provide the required logic state.

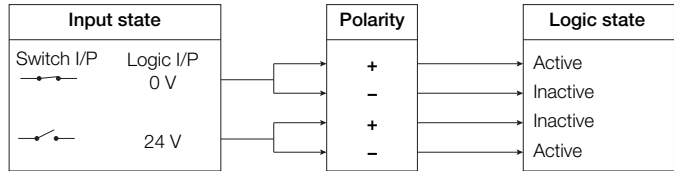

7.10.4 Ethernet module

The Ethernet module fitted to the recorder contains an embedded web server enabling the recorder's data and status to be viewed remotely using an internet browser on a PC. The web server supports up to 8 independent connections.

Ethernet

DHCP	Set to <i>Enabled</i> to enable the recorder to obtain a valid IP address automatically from a server on the network. Set to <i>Disabled</i> to enable the IP address to be configured manually.
------	---

IP-address	If DHCP is set to <i>Enabled</i> , the IP-address is assigned automatically and cannot be changed. If DHCP is set to <i>Disabled</i> , enter the IP-address assigned to the recorder. The IP address is used by the TCP / IP protocol to distinguish between different devices. The address is a 32 bit value expressed with four values (0 to 255), each separated by a period (.).
------------	---

Note. The following parameters are displayed only if DHCP is set to *Disabled*.

Subnet mask	The subnet mask is used to indicate which part of the IP address is for the network ID and which is for the host ID. Set as 1s each bit that is part of the network ID (for example, 255.255.255.0 indicates that the first 24 bits are for the network ID).
-------------	--

Default Gateway	Set the IP address for the default gateway (for example, router or switch) required to communicate with other networks. This setting may not be required. The default setting is 0.0.0.0.
-----------------	---

FTP

FTP user 1 (to 4) The FTP User name and password are used during logon to access the FTP server. Access for up to four different users is provided. These passwords can also be used to allow access to the functionality provided by the web server.

User name Enter a name for the user granted FTP access.

Password Enter a password for the user granted FTP access.

Access Level Select an FTP access level for the user:

Full – user can read, write and delete files.

Read-only – user can read files only.

Remote Operation Select an access level for Remote Operation by the user from the webserver:

None – user cannot log on to the recorder from a web browser.

Operator – user can acknowledge alarms and start, stop and reset totalizers from a web browser.

Configuration – user can load a new configuration into the recorder from a web browser. This is in addition to the operator functions.

Note. If a user is given full access via FTP, that user is able to delete both data and configuration files. This could result in erroneous operation of the recorder.

7.10.5 Email

The recorder can be configured to send emails to a maximum of 6 recipients in response to certain events. The addressees can all subscribe to the same SMTP server or the recorder can be configured to send emails via 2 different SMTP servers to a maximum of 3 addressees per server.

Up to 10 independently configurable triggers can be enabled to generate an email when the selected source becomes active.

When a trigger source becomes active, an internal 1 minute delay timer is started. At the end of that minute, an email is generated that includes, not only the event that initiated the delay timer, but every other event that occurred during the delay period together with any enabled reports. The data returned in the email therefore reflects the real-time alarm state at the time the email was generated, not the state when the first trigger source became active.

Each email includes a link to the recorder's embedded web server enabling the recorder's data and status to be viewed remotely using an internet browser on a PC.

Email

Auto Address

Touch  to toggle between *Enabled* and *Disabled*.

Set to *Disabled* if the sender address must contain a domain literal address (for example, the recorder's IP address) and enter the address in the **Sender Address** field (below).

Select *Enabled* if the sender address must be a domain name.

Sender Address

Note. Displayed only if **Auto Address** is set to *Disabled*.

Enter the address of the email sender.

Note. The address must contain a valid domain name.

Email 1 (2)

SMTP Server IP address	Enter the IP address of the SMTP server through which emails are to be routed.
Recipient 0 (to 2)	Enter the address(es) of the email recipient(s).
Options enabled	Select the options to enable.
Channels Report	When selected, a summary of all enabled channels together with their instantaneous values is included in the email.
Totalizers Report	When selected, a summary of all enabled totalizers together with their instantaneous values is included in the email.
External Media Report	When selected, a summary of the condition of the external media (if any) and archiving status is included in the email.
Reports in ALL emails	Reports, when enabled, are included only on an email generated as a result of a real-time alarm event. When Reports in ALL emails is selected, enabled reports are included on every email generated.
Trigger 6 (to 10) Inverted	Triggers 6 to 10, if enabled (see below), may be 'inverted'. An inverted trigger generates an email when the trigger source becomes inactive instead of active. Event trigger source types that cannot be inverted are: <i>Alarm acknowledge, Any alarm and New alarm.</i>
Trigger 1-5	Select up to 10 event source types to generate an email.
Trigger 6-10	

7.10.6 MODBUS TCP

MODBUS TCP enables MODBUS TCP devices to communicate via an ethernet network transferring MODBUS messages via TCP / IP. Communication with standard, serially connected, MODBUS RTU devices is also possible through a MODBUS TCP Gateway.

The recorder can be configured to act as either a MODBUS TCP Slave or a MODBUS TCP Master device on a MODBUS TCP network.

If configured as a Slave, the recorder responds to MODBUS queries transferred via the MODBUS TCP protocol for the registers described in Appendix B, page 149. The recorder can be configured for unrestricted access or access can be restricted to a maximum of 6 MODBUS TCP Masters, from defined IP addresses.

If configured as a Master, the recorder collects data from MODBUS TCP Slaves into its 24 Comms Analog and 24 Comms Digital Channels. Each analog and digital input can be configured individually to any register within any slave device. The configuration allows for receipt of data in most commonly used data formats

MODBUS TCP

Implementation	Select the required MODBUS TCP configuration. <i>Slave</i> – recorder acts as a MODBUS Slave. <i>Master</i> – recorder acts as a MODBUS Master. <i>Disabled</i> – MODBUS TCP disabled.
-----------------------	---

Note. The following parameters are displayed only if **Implementation** is set to *Slave* or *Master*.

MODBUS TCP Port	Set the TCP / IP port-through used by the MODBUS TCP network – normally port 502.
------------------------	---

Note. The following parameter is displayed only if **Implementation** is set to *Slave*.

Reverse IEEE Data	All analog data is read from the recorder in IEEE format contained in adjacent registers representing the data in high word, low word order. Select Yes to reverse the IEEE data, otherwise select No .
--------------------------	--

Note. The following parameters are displayed only if **Implementation** is set to *Master*.

Poll Rate (ms)	Set the poll rate in milliseconds – minimum 0, maximum 3600000.
----------------	---

Poll fail limit	Set the number of successive polls permitted to fail before the data is marked as a failed input – minimum 0, maximum 4.
-----------------	--

Response Timeout (ms)	Set the timeout time in milliseconds for a single poll – minimum 0, maximum 60000.
-----------------------	--

Note. If any RTU devices connected through a gateway are polled, set a response time that is long enough to allow for the normal turn around time from these devices. The configuration allows for only one setting for all devices connected to the network.

7.10.7 Slave authorization

Note. This tab is displayed only if only if **Implementation** on the **MODBUS TCP** tab is set to *Slave* – see page 121.

Slave Authorization

TCP Slave Access

Select the maximum number of simultaneous TCP / IP connections permitted:

- Unrestricted* – any number of MODBUS TCP Slave devices are permitted to poll the recorder.
- 1 (to 6)* – only the MODBUS TCP slave device(s) whose IP address(es) is (are) entered in the **Authorized IP 1** (to **Authorized IP 6**) parameter(s) (below) is (are) permitted to poll the recorder.

Note. The following parameter is displayed only if **TCP Slave Access** is not set to *Unrestricted*.

Authorized IP 1 (to 6)

Enter the IP address(es) of the MODBUS TCP Slave (MODBUS Master) device(s) that is (are) permitted to poll the recorder for data.

7.10.8 Comms analog input

Note. This tab is displayed only if only if **Implementation** on the **MODBUS TCP** tab is set to *Master* – see page 121.

Comms analog I/P

Comms analog I/P Select the communications analog input to hold the data from the nominated slave device.

Protocol Select the communications protocol to be used by the recorder to communicate with a nominated slave device:

- None* – comms analog channel unused.
- TCP* – MODBUS Transmission Control Protocol.
- RTU* – access a Remote Terminal Unit (RTU) via MODBUS TCP gateway.

Note. The following parameter is displayed only if **Protocol** is set to *TCP*.

IP-address Enter the IP address assigned to the slave device.

Note. The following parameters are displayed only if **Protocol** is set to *RTU*.

RTU Address Enter the RTU address assigned to the remote unit (1 to 247).

Gateway Set the IP address for the MODBUS TCP gateway for connection to the RTU.

Note. The remaining parameters are displayed only if **Protocol** is set to *TCP* or *RTU*.

Register Number Enter the register number to be read in the slave device.

Type Select the register type, *Holding Register* or *Input Register*.

Format Select the format of the data to be read from the slave device:

- Sint16* – signed, 16 bit integer
- Sint32* – signed, 32 bit integer, transmitted in high / low order
- rev. Sint32* – signed, 32 bit integer, transmitted in low / high order
- IEEE* – 32 bit floating point number, transmitted in high / low order
- Rev. IEEI* – 32 bit floating point number, transmitted in low / high order

7.10.9 Comms digital input

Note. This tab is displayed only if only if **Implementation** on the **MODBUS TCP** tab is set to *Master* – see page 121.

Comms digital I/P

Comms digital I/P Select the communications digital input to hold the status from the nominated slave device.

Protocol Select the communications protocol to be used by the recorder to communicate with a nominated slave device:

- None* – communications digital channel unused.
- TCP* – MODBUS Transmission Control Protocol.
- RTU* – access a Remote Terminal Unit (RTU) via MODBUS TCP gateway.

Note. The following parameter is displayed only if **Protocol** is set to *TCP*.

IP-address Enter the IP address assigned to the slave device.

Note. The following parameters are displayed only if **Protocol** is set to *RTU*.

RTU Address Enter the RTU address assigned to the remote unit (1 to 247).

Gateway Set the IP address for the MODBUS TCP gateway required to communicate with the RTU.

Note. This setting is always required to access a RTU via Ethernet.

Note. The remaining parameters are displayed only if **Protocol** is set to *TCP* or *RTU*.

Register Number Enter the register number to be read or written to in the slave device.

Type Select the register type, *Input Status* or *Coil Status*.

7.10.10 RS485 (MODBUS) communications

Note. This Section is applicable only if the optional MODBUS module is fitted.

Refer to Appendix B, page 149 for further information on using the MODBUS link.

RS485

Protocol	Select the MODBUS protocol required. <i>MODBUS Slave</i> – recorder operates as a MODBUS Slave <i>MODBUS Master</i> – recorder operates as a MODBUS Master
Type	Set according to the number of transmission wires connected to the recorder. <i>4-wire</i> <i>2-wire</i>
Baud rate	Set the Baud rate used by the host system: <i>1200, 2400, 4800, 9600, 19200, 38400, 115200.</i>
Parity	Set the Parity used by the host system: <i>None, Odd, Even.</i>
Address	Note. Displayed only if Protocol is set to <i>MODBUS Slave</i> . Set a unique MODBUS Address (between 1 and 247) to enable the host system to identify the recorder on a MODBUS link. Note. Maximum 32 slaves per loop.
Note. The remaining parameters are displayed only if Protocol is set to <i>MODBUS Master</i> .	
Poll rate	Set the poll rate in milliseconds – minimum 0, maximum 3600000.
Poll fail limit	Set the number of successive polls permitted to fail before the data is marked as a failed input – minimum 0, maximum 4.
Poll rate interval	Set the time interval between individual messages within a poll.
Response Timeout	Set the timeout time in milliseconds for a single poll – minimum 0, maximum 60000. Note. If any RTU devices are polled, set a response time that is long enough to allow for the normal turn around time from these devices. The configuration allows for only one setting for all devices connected to the network.

7.11 Functions

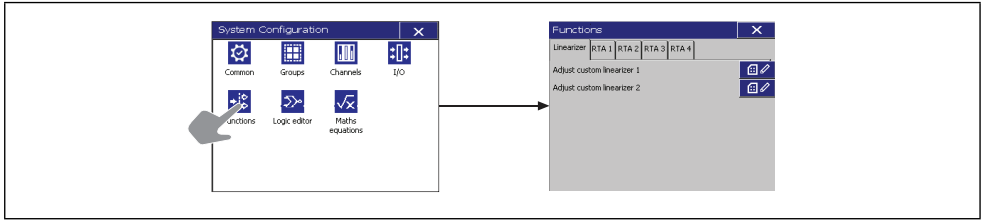

Fig. 7.17 Functions configuration

7.11.1 Custom linearizers

Linearizer

Adjust custom linearizer 1 (2)

Touch adjacent to the linearizer to be adjusted to open the Adjust custom linearizer screen.

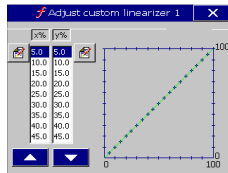

Touch or use / to select the point to be modified.

Touch to open the digipad to change the position of that point.

Touch to return to the Functions screen.

Each linearizer has 20 breakpoints. Both X and Y values are set as percentages.

Custom linearizers can be applied to any analog input by selecting them as the linearizer type for that input – see **Linearizer Type**, page 90.

Note.

- X is input to the linearizer expressed as a percentage of the electrical range.
- Y is output expressed as a percentage of the engineering range.

7.11.2 Real-time alarms

RTA1 (to 4)

Alarm tag	Enter the tag to be used in the Alarm Event log. Refer to Appendix F, page 180 for further information regarding character use in tags.
Daily enables	Select the day(s) on which the alarm is activated.
1st of month enable	Set to <i>On</i> to activate the real-time alarm on the first day of each month.
On time	Set the time at which the alarm becomes active. If <i>Every hour</i> is set to <i>On</i> , the <i>Hours</i> setting cannot be adjusted and the alarm is activated at the same time every hour (determined by the <i>Minutes</i> setting) or on the hour (if <i>Minutes</i> is set to <i>Off</i>).
Duration	Set the duration for the alarm to remain active.
Log enable	Set to <i>On</i> to add an entry to the Alarm Event log each time the real-time alarm becomes active.

7.12 Logic editor

Note. The logic equation editor tabs are displayed only if the Math / Logic option is enabled.

LE1 (to 24) Select the logic equation to create or modify.

Operand / Operator 1

Operand (1 to 6) Specify the first operand – can be any digital signal.

Invert condition Invert the signal, if required.

Operator (1 to 6) Select an operator for the next input – see Table 7.4.

Inputs	A	0	0	1	1
	B	0	1	0	0
	Operators	Outputs			
All inputs high	AND	0	0	1	1
Any (or All) input(s) low	NAND	1	1	1	0
Any (or All) input(s) high	OR	0	1	1	1
No inputs high	NOR	1	0	0	0
Any, but not All, input(s) high	XOR	0	1	1	0

Table 7.4 Logic operators

Repeat these steps until the equation is complete.

Eqtn tag & log enable

Equation tag Enter an equation tag (20 characters maximum) to be displayed in the Alarm Event log.
Refer to Appendix F, page 180 for further information regarding character use in tags.

Log enable Set to On to enable changes in the equation's state to be recorded in the Alarm Event log.

7.13 Math equations

Note.

- The math equations tabs are displayed only if the Math / Logic software option is enabled.
- Up to 24 math equations can be configured individually using the math pad – see see Fig. 7.19, page 133.
- A tag and an engineering range can be assigned to each math result.
- Up to 20 different preset functions can be used in math equations.
- Constants with up to 5 decimal places can be used in math equations.
- Each math equation can be up to 40 characters in length.
- Any number of digital signals can be assigned to each equation.
- Configurable fault detect level and drive per math block.
- Operators:
 - Add
 - Subtract
 - Multiply
 - Divide
 - Open Bracket
 - Close Bracket
 - Comma separator.

Individual recording channel signals, analog and digital sources and 7-digit totalizer values can be combined in a math equation to produce a customized recording channel or retransmission source.

Typical examples include adding / subtracting the values of a number of analog sources together to form one recording channel.

More complex blocks can also be created to determine relative humidity.

Digital signals can be used in math equations to enable / disable the output when certain conditions are true.

This is an example of a typical math equation:

$$mb1 = aiA1 + 52.4 \times \text{Log}(aiA2) - diD2$$

Where:

mb1 = Math result (can be assigned to, for example, recording channels, other math equations)

aiA1 = Analog source

52.4 = Constant (can be any numerical value of up to 3 decimal places)

Log(aiA2) = Function – see Table 7.5, page 132

diD2 = Digital source

Note.

- Operators are evaluated according to standard operator precedence; therefore, the above equation is evaluated as $aiA1 + (52.4 \times \text{Log}(aiA2)) - diD2$.
- Functions may be nested within other functions.
- Digital signals are evaluated as 0 (inactive) and 1 (active), therefore in the example:

$$mb2 = (aiA1 + aiA2) \times diD1$$

the sum of $(aiA1 + aiA2)$ is set to zero if the digital input $diD1$ is also zero.

7.13.1 Math functions

Function	Description
Trigonometric functions:	
SinR(x)	The sine of x (x specified in radians).
SinD(x)	The sine of x (x specified in degrees).
CosR(x)	The cosine of x (x specified in radians).
CosD(x)	The cosine of x (x specified in degrees).
TanR(x)	The tangent of x (x specified in radians).
TanD(x)	The tangent of x (x specified in degrees).
Logarithmic functions:	
Log(x)	Log base 10 of x.
Ln(x)	Natural log of x.
Exp(x)	e to the power x.
Statistical functions:	
Avg(x, n, t)	The average of variable x, over n samples at a sample rate of t seconds. The average resets after n samples.
Rav(x, n, t)	The rolling average of variable x, over n samples at a sample rate of t seconds. The oldest sample in each Rav calculation is lost and the new result is calculated by taking into account the current sample.
Sd(x, n, t)	Standard Deviation of variable x, over n samples at a sample rate of t seconds.
Power functions:	
X ^a (x, a)	Raises the variable x to the power a.
Sqr(x)	Returns the square root of variable x.
Special functions:	
RH(x, y)	Relative humidity calculation using wet (x) and dry (y) bulb readings.
Abs(x)	The absolute value of variable x.
Switch functions:	
Hs(x, y, z)	Returns the variable with the greatest magnitude.
Ms(x, y, z)	Returns the variable whose magnitude is between the upper and lower limits of the 3 variables.
Ls(x, y, z)	Returns the variable with the smallest magnitude.
Mux(x, y, s)	Selects x if s is false, otherwise selects y.

Table 7.5 Math functions

7.13.2 Using the math pad

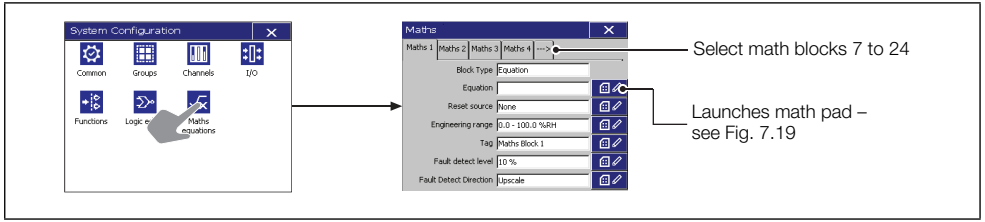

Fig. 7.18 Launching the math pad

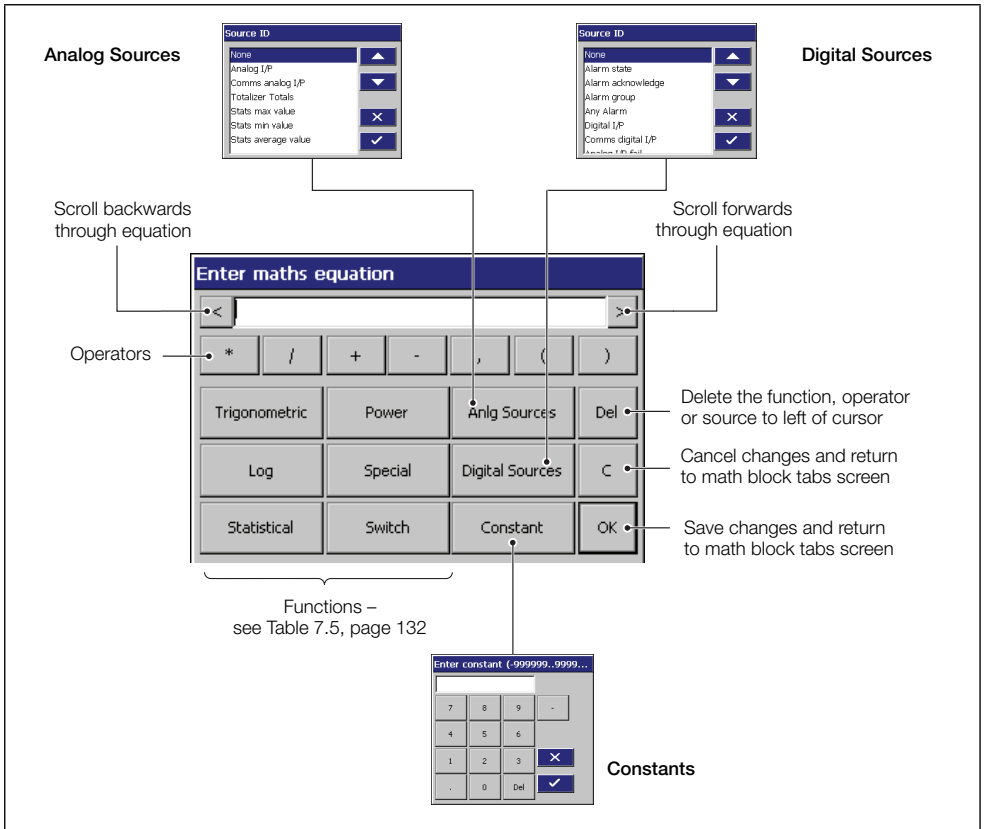

Fig. 7.19 Math pad

7.13.3 Relative humidity calculation

Relative humidity is calculated using the following formula:

$$RH = 100 \times \frac{VPSw - AP \times (Td - Tw)}{VPSd}$$

Where:

VPSw = Saturation vapor pressure at wet bulb temperature

VPSd = Saturation vapor pressure at dry bulb temperature

Td = Dry bulb temperature

Tw = Wet bulb temperature

P = Total atmospheric pressure (1000 mbar)

A = Psychometric constant (6.66×10^{-4})

RH = % of relative humidity

A relative humidity (RH) calculation requires two inputs, one from a wet bulb sensor and one from a dry bulb sensor. Both of these inputs are incorporated into the equation as analog.

RH tables are based on the use of an aspirated psychrometer that has an air velocity of at least 3.5 meters (11.5 feet) per second across the bulb sensors.

Inputs used for wet and dry bulb measurement must be in the ranges 0 to 100 °C (32 to 212 °F). The result must be set to 0 to 100.0 % RH.

Fig. 7.20 (page 135) is an example of configuring a math block to perform a relative humidity calculation.

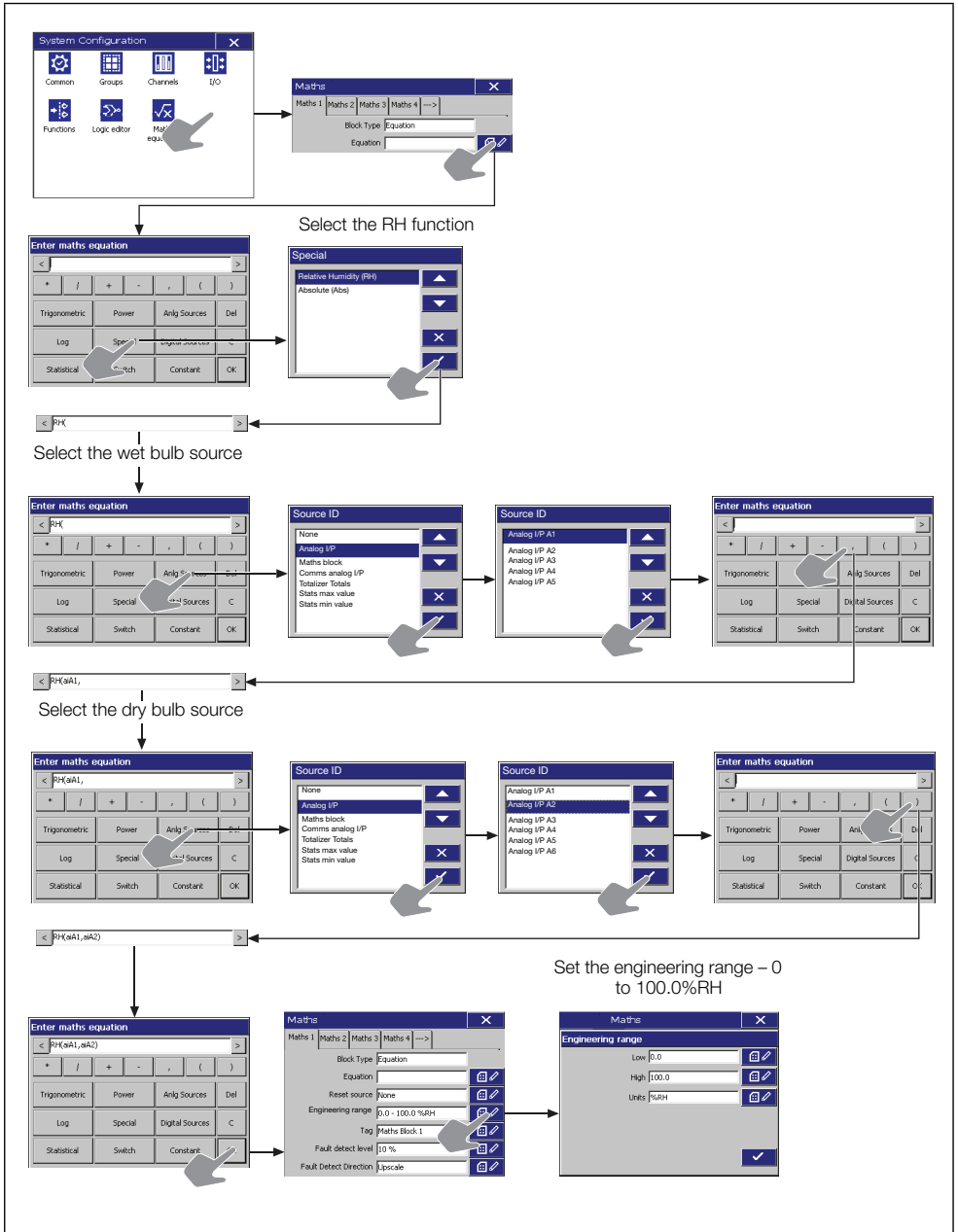

Fig. 7.20 Relative humidity calculation

7.13.4 Math block configuration

Maths 1 (to 24)	Select the math block to create or modify.
Block Type	Fixed as Equation .
Equation	Create the equation using the math pad – see Fig. 7.19, page 133.
Reset source	Select a digital source (for example, alarm signal, real-time event) to be used to reset the equation if required.
Engineering range	Specify the display range and units of the engineering value.
Low	<p>Example – maximum and minimum calculated values function:</p> $a1 + a2$ <p>where:</p> $a1 \equiv 0 \text{ to } 150 \text{ l/s}$ $a2 \equiv -50 \text{ to } 100 \text{ l/s}$ <p>Engineering High = 250.0 Engineering Low = -50.0</p> <p>Note. For the best resolution enter engineering ranges to the maximum permissible number of decimal places.</p>
High	
Units	
Tag	<p>Enter the tag name to be displayed on channel indicators and used to identify the channel in archive files. (16 characters maximum).</p> <p>Refer to Appendix F, page 180 for further information regarding character use in tags.</p>
Fault detect level	<p>Set a tolerance level (between 0 and 100% of the engineering range) to allow for deviation of the input signal above or below the input span before an input failure is detected.</p> <p>Example – setting the fault detection level to 10% on an input range of 50 to 250 bar causes an analog input failure fault to be detected below 30 bar and above 270 bar.</p>
Fault Detect Direction	<p>In the event of a math block failure, the result can be driven upscale or downscale.</p> <p><i>Upscale</i> – math result value driven beyond full scale.</p> <p><i>Downscale</i> – math result value driven below zero.</p>

8 Specification

Operation and configuration

Configuration

Via resistive touchscreen or PC Configuration

Multiple configuration files can be stored in internal memory (up to 16 files) or external memory (SD card, USB flash drive)

Display

Color, TFT, liquid crystal display (LCD) with LED backlight and brightness adjustment

144 mm (5.7 in.) diagonal display area, 76800 pixel (1/4 VGA) display *

* A small percentage of the display pixels may be either constantly active or inactive. Maximum percentage of inoperative pixels < 0.01 %

Language

English, German, French, Italian, Spanish, Chinese

Chart screen intervals

Selectable from 18 seconds to 7 days

Chart divisions

Programmable for up to 10 major and 10 minor divisions

Chart annotation

Alarm, batch, electronic signatures and operator messages may be annotated on the chart

Real-time clock

Accuracy: ±5 ppm (±0.43 seconds per day)

Back-up battery: Battery low warning
Provides 3 years support for unpowered condition
10 year shelf-life

Security

Physical

Lockable media door

Front and rear tamper-evident seals

Configuration security

Password protection: Access to configuration is enabled only after the user has entered a password

Internal switch protection: Access to configuration is enabled only after a hardware switch has been set. This switch is situated behind a tamper-evident seal

Logging security

Configuration: Can be configured for password protection or free access to logging level

Basic type security

4 individual users with unique user name and passwords

Advanced type security

Number of users: Up to 40

User names: * Up to 20 characters

Access privileges: Logging access – Yes / No
Configuration access – none / load file only / limited / full

Passwords: Up to 20 characters
A minimum required password length of 4 to 20 characters can be configured and a password expiry time can be applied to eliminate password ageing

Password failure limit: Configurable for 1 to 10 consecutive occasions or 'infinite'
A user is deactivated if a wrong password is entered repeatedly

Deactivation of inactive users: Can be disabled or configured for 7, 14, 30, 60, 90, 180 or 360 days of inactivity
Users are deactivated (by removal of access privileges) after a period of inactivity

* User names are unique (names cannot be repeated)

Operator views

Contents	Views available		
	Chart	Bargraph	Digital indicator
Instantaneous values / states	✓	✓	✓
Units of measure	✓	✓	✓
Channel tags	✓	✓	✓
Alarm status	✓	✓	✓
Alarm trip markers	—	✓	✓
Max. / Min. markers	—	✓	✓
Analog bargraphs	—	✓	✓
Totalizer values & units of measure	—	—	✓ *
Totalizer tags	—	—	✓ *
Maximum, minimum and average batch values	—	—	✓ *
Graphical view of historical data	✓	—	—

* If Totalizer option is fitted and selected

Standard functionality

Operator messages

Number:	24
Trigger:	Via front panel or digital signals
Recording in alarm / event log:	Can be enabled or disabled on configuration

Secure chart signatures

Recorded in the alarm / event log, complete with operator identification

Process alarms

Number:	96 (4 per recording channel)
Types:	High / low: Process Latch Annunciator
Rate:	Fast / slow
Tag:	20-character tag for each alarm
Hysteresis:	Programmable value and time hysteresis (1 to 9999 seconds)
Alarm enable:	Allows alarm to be enabled / disabled via a digital input
Alarm log enable:	Recording of alarm state changes in the alarm / event log can be enabled / disabled for each alarm
Acknowledgement:	Via front panel or digital signals

Real-time alarms

Number:	4
Programmable:	Day of the week, 1 st of month, start and duration times

Custom linearization

Number:	2
Number of breakpoints:	20 per linearizer

Recording to internal memory

- Internal flash memory: 256 MB flash memory upgradeable to 2 GB
Oldest data is automatically overwritten by new data when memory is full
- Data integrity checks: Checksum for each block of data samples
- Independent process groups: 6 (maximum of 24 channels per group)
- Number of recording channels: 24 (each channel can be assigned to 1 group only) *
- Sources: Any analog or digital signal (for example, process input, communications, math block and totalizer)
- Filters:
 - Programmable for each channel to allow recording of:
 - Instantaneous values
 - Average
 - Maximum, minimum
 - Maximum and minimum value over sample time
- Primary / Secondary sample rates: Programmable from 0.125 seconds to 60 minutes for each process group
- Primary / Secondary sample rate selection: Via any digital signal or from password protected menu
- Recording start / stop control: Via any digital signal

* If required, a single process input can be assigned to multiple recording channels enabling it to be visible in more than one process group.

Recording duration to 256 MB internal flash memory

Approximate duration calculated for continuous recording of 6 channels of analog data (for example, for 12 channels divide by 2, for 24 channels divide by 4).

Sample rate	Duration
0.125 seconds	10 days
1 second	80 days
10 seconds	2.2 years
60 seconds	13 years
10 minutes	130 years
60 minutes	960 years

Recording duration to 2 GB internal flash memory

Approximate duration calculated for continuous recording of 24 channels of analog data (for example, for 12 channels multiply by 2, for 6 channels multiply by 4).

Sample rate	Duration
0.125 seconds	20 days
1 second	160 days
10 seconds	4.4 years
60 seconds	26 years
10 minutes	260 years
60 minutes	1920 years

Historical logs

Types: Alarm / event, totalizer and audit logs

Number of records in each historical log: Up to 500 in internal memory
Oldest data is automatically overwritten by new data when log is full

	Alarm / event log		Totalizer log		Audit log	
Log entry events	<ul style="list-style-type: none"> • Alarm state changes • Operator messages 		<ul style="list-style-type: none"> • User defined logging intervals • Totalizer stop / start, reset, wrap • Power up / down 		<ul style="list-style-type: none"> • Configuration / calibration changes • System events • Errors, operator actions 	
Information recorded in log / on screen	In log	On screen	In log	On screen	In log	On screen
Date & time of event	✓	✓	✓	✓	✓	✓
Type of event	✓	✓	✓	✓	✓	✓
Tag	✓	✓	✓	✓	–	–
Source tag	✓	–	✓	–	–	–
Alarm trip value & units of measure	✓	–	–	–	–	–
Alarm state	✓	✓	–	–	–	–
Alarm acknowledgement state	✓	✓	–	–	–	–
Operator ID	✓	–	–	–	✓	✓
Description	–	–	–	–	✓	✓
Batch total and units of measurement*	–	–	✓	✓	–	–
Maximum, minimum and average values plus units*	–	–	✓	✓	–	–
Secure total	–	–	✓	–	–	–

* If Totalizer option fitted and selected

Archiving to removable media

Data that can be saved to removable media:	Recorded data per channel (1 to 24) Alarm event log data Totalizer log data Audit log data Configuration
File structure:	Binary encoded
File protection:	Secure binary format with data integrity checks
New file generation interval:	Automatic
Archive sample rates:	Data is archived at the same sample rate at which it is stored internally
Filename:	20-character tag, prefixed with date / time
Data verification:	Carried out automatically on all writes to removable-media files

SD card size

Cards up to 32 GB capacity may be used

USB flash drive size

Drives up to 32 GB capacity may be used

Archive media compatibility

ABB recorders comply with approved industry standards for SD cards and USB flash drives. ABB fully tests the brands of SD cards and USB flash drives that it supplies. Other brands may not be fully compatible with this device and therefore may not function correctly.

Recording duration

Approximate duration calculated for continuous recording of 6 channels of analog data (for example, for 12 channels divide by 2, for 3 channels multiply by 2).

Sample rate	Duration	
	512 MB SD Card	1 GB SD Card
1 seconds	8 months	16 months
10 seconds	6 years	13 years
40 seconds	26 years	51 years
60 seconds	40 years	75 years
120 seconds	80 years	255 years
480 seconds	315 years	620 years

Analog input modules

General

Number of process inputs:	6 per module, maximum of 24 inputs
Input types:	mA, mV, voltage, resistance, thermocouple, RTD, digital volt-free, digital 24 V
Thermocouple types:	B, C, D, E, J, K, L, N, R, S, T
Resistance thermometer:	PT100, PT1000, Ni120, Ni1000
Other linearizations:	\sqrt{x} , $x^{3/2}$, $x^{5/2}$, custom linearization
Digital filter:	Programmable 0 to 60 seconds
Display range:	-999999 to 9999999
Common mode noise rejection:	>120 dB at 50 / 60 Hz with 300 Ω imbalance resistance
Normal (series) mode noise rejection:	>60 dB at 50 / 60 Hz
CJC rejection ratio:	± 0.05 $^{\circ}\text{C} / ^{\circ}\text{C}$ CJC error 0.5 $^{\circ}\text{C}$ maximum with recorder @ 25 $^{\circ}\text{C}$
Sensor break protection:	Programmable as upscale or downscale
Temperature stability:	0.02 % / $^{\circ}\text{C}$ or 2 $\mu\text{V} / ^{\circ}\text{C}$ (non-thermocouple ranges only)
AMS 2750 E:	Subject to suitable field calibration, meets the requirements of 'Control, Monitoring and Recording Instruments' and 'Field Test Instruments'
Long term drift:	<0.1 % of reading or 20 μV annually
Input impedance:	>10 M Ω (millivolts inputs) >900 k Ω (voltage inputs) 10 Ω (mA inputs)

Inputs

Linear inputs	Standard analog input	Accuracy (% of reading)
Millivolts	-150 to 150 mV	0.1 % or $\pm 20 \mu V$
Milliamperes	-50 to 50 mA	0.1 % or $\pm 10 \mu A$
Volts	-10 to 24 V*	0.1 % or $\pm 10 mV$
Resistance Ω (low)	0 to 550 Ω	0.1 % or $\pm 0.5 \Omega$
Resistance Ω (high)	0 to 10000 Ω	0.1 % or $\pm 5 \Omega$
Sample interval	125 ms per sample (all inputs are processed in parallel)	
Channel-to-channel input isolation	Galvanically isolated to 500 V DC	
Isolation from rest of recorder	Galvanically isolated to 500 V DC	

The figures in the following table include linearizer and electrical errors

Thermocouple	Maximum range		Measurement accuracy (% of reading)
	$^{\circ}C$	$^{\circ}F$	
B	250 to 1800	482 to 3272	0.1 % or $\pm 1 ^{\circ}C$ (1.8 $^{\circ}F$)
C	0 to 2300	32 to 4172	0.1 % or $\pm 0.5 ^{\circ}C$ (0.9 $^{\circ}F$)
D	0 to 2310	32 to 4190	0.1 % or $\pm 1.5 ^{\circ}C$ (2.7 $^{\circ}F$)
E	-100 to 900	-148 to 1652	0.1 % or $\pm 0.3 ^{\circ}C$ (0.54 $^{\circ}F$)
J	-100 to 900	-148 to 1652	0.1 % or $\pm 0.3 ^{\circ}C$ (0.54 $^{\circ}F$)
K	-100 to 1300	-148 to 2372	0.1 % or $\pm 0.3 ^{\circ}C$ (0.54 $^{\circ}F$)
L	-100 to 900	-148 to 1652	0.1 % or $\pm 0.3 ^{\circ}C$ (0.54 $^{\circ}F$)
N	-200 to 1300	-328 to 2372	0.1 % or $\pm 0.3 ^{\circ}C$ (0.54 $^{\circ}F$)
R	-50 to 1700	-58 to 3092	0.1 % or $\pm 0.3 ^{\circ}C$ (0.54 $^{\circ}F$) (above 300 $^{\circ}C$ [572 $^{\circ}F$])
S	-50 to 1700	-58 to 3092	0.1 % or $\pm 0.3 ^{\circ}C$ (0.54 $^{\circ}F$) (above 200 $^{\circ}C$ [392 $^{\circ}F$])
T	-200 to 300	-328 to 572	0.1 % or $\pm 0.3 ^{\circ}C$ (0.54 $^{\circ}F$)

RTD			
PT100	-200 to 600	-328 to 1112	0.1 % or $\pm 0.5 ^{\circ}C$ (0.9 $^{\circ}F$)
PT1000 (IEC 60 751)	-200 to 850	-328 to 1562	0.1 % or $\pm 0.5 ^{\circ}C$ (0.9 $^{\circ}F$)
Ni120	-80 to 260	-112 to 500	0.1 % or $\pm 0.5 ^{\circ}C$ (0.9 $^{\circ}F$)
Ni1000	-30 to 130	-22 to 266	0.1 % or $\pm 0.5 ^{\circ}C$ (0.9 $^{\circ}F$)

Advanced math (optional)

Type

24 equations provide ability to perform general arithmetic calculations including mass flow (of ideal gases), relative humidity and emissions calculations

Size

40-character equation

Functions

+, -, /, log, Ln, Exp, Xn, $\sqrt{\quad}$, Sin, Cos, Tan, mean, rolling average, standard deviation, high / median / low select, multiplexer, absolute, relative humidity

Tags

8- and 20-character tags for each block

Update rate

1 enabled Math block is updated every 125 ms

Logic equations (optional)

Number

24

Size

11 elements each

Functions

AND, OR, NAND, NOR, XOR, NOT

Tags

20-character tag for each equation

Update rate

300 ms

Totalizer (optional)

Number

48 (2 per recording channel) 10-digit totals

Type

Analog, digital or F_0 , batch, secure totals

Statistical calculations

Average, maximum, minimum (for analog signals)

6-Relay module

Number of relays

6 per module

Type and rating

Relay type single-pole changeover

Voltage: 250 V AC, 30 V DC

Current: 5 A AC, 5 A DC

Loading (non-inductive): 1250 VA, 150 Ω

Note. The total load for all relays within the recorder must not exceed 36 A.

Hybrid module

6 Analog blocks + 5 digital inputs

Analog block

Number: 6, galvanically isolated

Configuration options: Analog output, digital output or transmitter PSU

Analog output

Configurable current range: 0 to 20 mA

Maximum load: 750 Ω

Isolation: 500 V DC from any other I/O

Accuracy: 0.25 %

Digital output

Voltage: 24 V (nominal)

Drive: 22.5 mA

Isolation: 500 V DC from any other I/O

Transmitter PSU

22.5 mA at 24 V DC (nominal)

Isolation: 500 V DC from any other I/O

Digital input

Number: 5

Type: Volt-free switching inputs

Polarity: Negative (closed switch contact or 0 V = active signal)

Digital input minimum pulse: 125 ms

Isolation: 500 V DC from any other I/O *

* No isolation between digital I/O on the same module

Ethernet module

Physical medium

10 / 100BaseT

Protocols

TCP / IP, ARP, ICMP, FTP (server), HTTP, MODBUS TCP (master / slave), SNTIP

FTP server functions

Directory selection & listing

File upload / download

4, independently configurable users with full or read-only access

Web server functions

Operator screen monitoring / selection

Remote monitoring of recording channels, analog / digital signals, alarms, totalizers and archiving

RS485 serial communications module

Number of ports

1 as option

Connections

RS485, 2- or 4-wire

Protocol

MODBUS RTU slave + master

Isolation:

500 V DC from rest of recorder

EMC

Emissions & Immunity

Meets requirements of: EN50081-2
EN50082-2
EN61326 for an industrial environment

Electrical

Power supply

100 to 240 V AC ± 10 % (90 min. to 264 V max.)
50 / 60 Hz
24 V DC (23.0 to 24.5 V DC)

Power consumption

43 VA max.

Power interruption protection

No effect for interruptions of up to 20 ms

Safety

General safety

EN61010-1

cULus

Overvoltage Class III on mains, Class II on inputs and outputs

Pollution category 2

Isolation

500 V DC to earth (ground)

Environmental

Operating temperature range

0 to 50 °C (32 to 122 °F) with SD card

Operating humidity range

5 to 95 % RH (non-condensing)

Storage temperature range

-10 to 60 °C (14 to 140 °F)

Front panel sealing

IP66 and NEMA4X

Rear panel sealing

IP40 (with rear cover)

IP20 (without rear cover)

Vibration

Conforms to EM60068-2

Physical

Size

Height and width: 144 x 144 mm (5.7 x 5.7 in.)

Depth behind panel 147 mm (5.8 in.)
(including terminal cover):

Weight

2.0 kg (4.4 lb) approx. (unpacked)

Panel cutout

138 mm (5.43 in.) x 138 mm (5.43 in.)

Case / Bezel material

10 % glass-filled polycarbonate

Touchscreen material

Polyester (EBA 250)

DS/RVG200-EN Rev. A

Appendix A – Signal sources

Source Name	Description
Analog Sources	
Analog I/P A1 to D24	Analog input values (from Analog input module). Available only if an analog input module is fitted in the relevant position.
Comms AIN 1 to 24	Communications analog input values. Received via the MODBUS serial communications link – see Table B.16, page 164.
Stats 1A max to Stats 24B max	Maximum statistics input value. Value since the totalizer on a given channel last wrap or reset. Available only if the totalizer option is enabled, only on analog channels and only if the relevant totalizer is enabled during configuration.
Stats 1A min to Stats 24B min	Minimum statistics input value. Value since the totalizer on a given channel last wrap or reset. Available only if the totalizer option is enabled, only on analog channels and only if the relevant totalizer is enabled during configuration.
Stats 1A avg to Stats 24B avg	Average statistics input value. Value since the totalizer on a given channel last wrap or reset. Available only if the totalizer option is enabled, only on analog channels and only if the relevant totalizer is enabled during configuration.
Math blocks 1 to 24	Math block result. Available only if the Math and Logic option is enabled and the relevant math block is enabled during configuration.
Error States	
AIN A1 to D6 Fail State	Analog input failure. Active when the signal detected at the analog input is outside the Fault Detect Level specified during configuration – see page 93.
Comms AIN 1 to 24 Fail State	
Stats 1A to Stats 24B fail	Totalizer input value failure. Activated when the totalizer fails, cleared when the totalizer wraps or is reset. Available only if the totalizer option is enabled, only on analog channels and only if the relevant totalizer is enabled during configuration.
Arc media not present	Active when the removable archive media is not present.
Archive 100% full	Active when the removable archive media is 100% full
Archive 80% full	Active when the removable archive media is 80% full.

Table A.1 Signal sources

Source Name	Description
Digital Input States	
Digital I/P A1 to D6	<p>Digital input states. Digital signals received from analog input modules fitted at module positions A to D (if input Type is set to <i>Volt-free Digital Input</i> or <i>24V Digital Input</i> during configuration – see page 90) and digital inputs from hybrid modules fitted at module positions C and D. Available only if the module is fitted.</p>
Comms Dig I/P 1 to 24	<p>Digital input states. Digital signals received via MODBUS serial link – see Table B.16, page 164.</p>
Alarm state 1A to 24D	<p>Alarm states. Available only if the relevant alarm is enabled during configuration.</p>
Alarm ack state 1.1A to 6.6D	<p>Alarm acknowledge states. Acknowledged alarm = 0; Unacknowledged alarm = 1. Process, Latch and Annunciator alarms only. Available only if the relevant alarm is enabled during configuration.</p>
Alarm group 1 to 12	<p>Alarm groups. Active only if any of the alarms assigned to a group are active. Available only if any alarms are enabled during configuration.</p>
Any Alarm	<p>Active only if any of the enabled alarms are active. Available only if there is at least one alarm enabled during configuration.</p>
New Alarm	<p>Causes an e-mail to be generated if any alarm becomes active. Available only as a source for e-mail triggers.</p>
Real-time alarm 1 to 4	<p>Real-time alarm states. Available only if the relevant alarm is enabled during configuration.</p>
Run state 1A to 24B	<p>Totalizer run states. Active while the totalizer is running. Available only if the totalizer option is enabled and the relevant totalizer is enabled during configuration.</p>
Wrap pulse 1A to 24B	<p>Totalizer wrap pulse. If Wrap enable is set to <i>On</i> (see page 102) – active for 1 second when the predetermined count has been reached. If Wrap enable is set to <i>Off</i> (see page 102) – active when the predetermined count has been reached and remains active until the totalizer is reset Available only if the totalizer option is enabled and the relevant totalizer is enabled during configuration.</p>
1st Stage O/P 1A to 24B	<p>Totalizer first stage output (intermediate count). Active for 1 second when the intermediate count has been reached. Available only if the totalizer option is enabled and the relevant totalizer is enabled during configuration.</p>

Table A.1 Signal sources (Continued)

Source Name	Description
Count pulse 1A to 24B	<p>Totalizer count pulse.</p> <p>Active for 100 ms each time the totalizer updates by one whole count. For example, if two decimal places are set, a pulse is generated when the totalizer value increments from 0.99 to 1.00 or 1.99 to 2.00</p> <p>Available only if the totalizer option is enabled and the relevant totalizer is enabled during configuration.</p>
Logic equation 1 to 24	<p>Logic equation result.</p> <p>Available only if the Math and Logic option is enabled and the relevant logic equation is enabled during configuration.</p>
Any Electronic Signature	
Batch Power Failure Abort	On signal pulse after power up.
Group Batch Running	On signal while running.
Hybrid Dgtl I/P C1 to D5	<p>Digital input states.</p> <p>Digital signals received from hybrid modules fitted at module positions C and D.</p> <p>Available only if the module is fitted.</p>
Arc media present	Active when the removable archive media is present.
Archive on-line	Active when archiving is in progress.

Table A.1 Signal sources (Continued)

Appendix B – MODBUS TCP / MODBUS 485

B.1 Introduction

The recorder can be configured to act as either a MODBUS TCP Master or Slave or, when fitted with an optional MODBUS / RS485 serial communications module, a MODBUS RS485 (RTU) Master or Slave.

If configured as a Master, the recorder collects data from MODBUS TCP servers (or RTUs via a gateway) into its **Comms Analog** and **Comms Digital Channels**.

If configured as a Slave the recorder responds to MODBUS queries transferred via the MODBUS TCP or MODBUS RS485 (RTU) protocol for the registers described in this appendix.

Note. The MODBUS RS485 option provides the following functions:

- Standard RS422/485 communications.
- MODBUS RTU protocol – for master (host computer/plc) to slave.
- 500 V DC isolation from external connections to the recorder.
- 2- or 4-wire communication.
- 1200, 2400, 4800, 9600, 19200, 38400 or 115200 baud transmission rate.
- Parity-checking – odd, even or none.

B.2 MODBUS commands supported

The following MODBUS commands are supported:

- 01 **Read coil status** – reads the on / off status of 16 consecutive digital states, starting at a specified address. The recorder returns zeros for points that do not contain defined data.
- 03 **Read holding registers** – reads 8 consecutive analog values, starting from a specified address. The recorder returns zeros for registers that do not contain defined data.
- 05 **Force single coil** – sets the value of a single coil (digital signal) at the specified address. The data value must be FF00Hex to set the signal *ON* and zero to turn it *OFF*. The recorder returns an exception response if the register is not currently writable.
- 06 **Preset single register** – sets the value of a single register (analog value) at the specified address. The recorder returns an exception response if the register is not currently writable. Limits defined in configuration are applied to the value before storage.
- 15 **Force multiple coils** – the recorder performs updates that are valid and returns an exception response if any of the coils are not currently writable.
- 16 **Preset multiple registers** – the recorder performs updates that are valid and generates an exception response if any of the registers are not currently writable.

B.3 MODBUS exception responses

If the recorder detects one of the errors shown in Table B.1 while receiving a message from the host system, it replies with a response message consisting of the recorder's MODBUS address, the function code, the error code and the error check fields.

Code	Name	Definition
01	Illegal function	The message function received is not an allowable action
02	Illegal data address	The address reference in the data field is not an allowable address
03	Illegal data value	The value referenced in the data field is not allowable in the addressed slave
07	Negative acknowledgement	Received message error
08	Memory parity error	Parity check indicates an error in one or more of the characters received

Table B.1 MODBUS exception responses

Note.

- Negative numbers are represented in '2's complement' format, for example, 1000 = 03E8 (Hex), -1000 = FC18 (Hex).
- The recorder cannot accept a new message until the current message has been processed and a reply sent to the master (maximum response time 50 ms).
- The recorder monitors the elapsed time between receipt of characters from the host. If the elapsed time between two characters is 3.5 character times, the slave assumes the second character received is the start of a new message.

B.4 Operating mode MODBUS coils

Tables B.2 to B.11 detail the contents of each MODBUS coil. Each coil is assigned a register that can have one of two values: 0000 and 0001.

Read only: 0 = OK, 1 = Fail	
Analog input	MODBUS coil
A1	0001
A2	0002
A3	0003
A4	0004
A5	0005
A6	0006
B1	0007
B2	0008
B3	0009
B4	0010
B5	0011
B6	0012

Read only: 0 = OK, 1 = Fail	
Analog input	MODBUS coil
C1	0013
C2	0014
C3	0015
C4	0016
C5	0017
C6	0018
D1	0019
D2	0020
D3	0021
D4	0022
D5	0023
D6	0024

Table B.2 Analog input fail states

	Active / Inactive state	Acknowledge state
Read access	0 = Inactive 1 = Active	0 = Acknowledged or inactive 1 = Active and unacknowledged
Write access	None	0 = No effect 1 = Acknowledge
Alarm	MODBUS coil	MODBUS coil
1A	101	200
1B	102	201
1C	103	202
1D	104	203
2A	105	204
2B	106	205
2C	107	206
2D	108	207
3A	109	208
3B	110	209
3C	111	210
3D	112	211

	Active / Inactive state	Acknowledge state
Read access	0 = Inactive 1 = Active	0 = Acknowledged or inactive 1 = Active and unacknowledged
Write access	None	0 = No effect 1 = Acknowledge
Alarm	MODBUS coil	MODBUS coil
13A	149	249
13B	150	250
13C	151	251
13D	152	252
14A	153	253
14B	154	254
14C	155	255
14D	156	256
15A	157	257
15B	158	258
15C	159	259
15D	160	260

Table B.3 Alarm states

	Active / Inactive state	Acknowledge state
Read access	0 = Inactive 1 = Active	0 = Acknowledged or inactive 1 = Active and unacknowledged
Write access	None	0 = No effect 1 = Acknowledge
Alarm	MODBUS coil	MODBUS coil
4A	113	212
4B	114	213
4C	115	214
4D	116	215
5A	117	216
5B	118	217
5C	119	218
5D	120	219
6A	121	220
6B	122	221
6C	123	222
6D	124	223
7A	125	225
7B	126	226
7C	127	227
7D	128	228
8A	129	229
8B	130	230
8C	131	231
8D	132	232
9A	133	233
9B	134	234
9C	135	235
9D	136	236
10A	137	237
10B	138	238
10C	139	239
10D	140	240
11A	141	241
11B	142	242
11C	143	243
11D	144	244

	Active / Inactive state	Acknowledge state
Read access	0 = Inactive 1 = Active	0 = Acknowledged or inactive 1 = Active and unacknowledged
Write access	None	0 = No effect 1 = Acknowledge
Alarm	MODBUS coil	MODBUS coil
16A	161	261
16B	162	262
16C	163	263
16D	164	264
17A	165	265
17B	166	266
17C	167	267
17D	168	268
18A	169	269
18B	170	270
18C	171	271
18D	172	272
19A	173	273
19B	174	274
19C	175	275
19D	176	276
20A	177	277
20B	178	278
20C	179	279
20D	180	280
21A	181	281
21B	182	282
21C	183	283
21D	184	284
22A	185	285
22B	186	286
22C	187	287
22D	188	288
23A	189	289
23B	190	290
23C	191	291
23D	192	292

Table B.3 Alarm states (Continued)

	Active / Inactive state	Acknowledge state
Read access	0 = Inactive 1 = Active	0 = Acknowledged or inactive 1 = Active and unacknowledged
Write access	None	0 = No effect 1 = Acknowledge
Alarm	MODBUS coil	MODBUS coil
12A	145	245
12B	146	246
12C	147	247
12D	148	248

	Active / Inactive state	Acknowledge state
Read access	0 = Inactive 1 = Active	0 = Acknowledged or inactive 1 = Active and unacknowledged
Write access	None	0 = No effect 1 = Acknowledge
Alarm	MODBUS coil	MODBUS coil
24A	193	293
24B	194	294
24C	195	295
24D	196	296

Table B.3 Alarm states (Continued)

Read only: 0 = Alarm group inactive 1 = Alarm group active	
Alarm group	MODBUS coil
Alarm group 1	301
Alarm group 2	302
Alarm group 3	303
Alarm group 4	304
Alarm group 5	305
Alarm group 6	306

Table B.4 Alarm groups

Read only: 0 = Alarm group inactive 1 = Alarm group active	
Alarm group	MODBUS coil
Alarm group 7	307
Alarm group 8	308
Alarm group 9	309
Alarm group 10	310
Alarm group 11	311
Alarm group 12	312

Read only: 0 = All alarms inactive 1 = At least 1 alarm active	
Title	MODBUS coil
Any alarm	325

Table B.5 Any alarm

Read only: 0 = Alarm inactive 1 = Alarm active	
Real-time alarm	MODBUS coil
Real-time alarm 1	331
Real-time alarm 2	332

Table B.6 Real-time alarms

Read only: 0 = Alarm inactive 1 = Alarm active	
Real-time alarm	MODBUS coil
Real-time alarm 3	333
Real-time alarm 4	334

Read: Always returns '0' Write: 1 = Activate	
Operator message	MODBUS coil
Operator Message 1	350
Operator Message 2	351
Operator Message 3	352
Operator Message 4	353
Operator Message 5	354
Operator Message 6	355
Operator Message 7	356
Operator Message 8	357
Operator Message 9	358
Operator Message 10	359
Operator Message 11	360
Operator Message 12	361

Table B.7 Operator messages

Read: Always returns '0' Write: 1 = Activate	
Operator message	MODBUS coil
Operator Message 13	362
Operator Message 14	363
Operator Message 15	365
Operator Message 16	366
Operator Message 17	367
Operator Message 18	368
Operator Message 19	369
Operator Message 20	370
Operator Message 21	371
Operator Message 22	372
Operator Message 23	373
Operator Message 24	374

Operator message	MODBUS coil	Read	Write
Assign to Group 1	375	0 = Remote operator message not assigned to group	0 = Unassign remote operator message from group
Assign to Group 2	376	1 = Remote operator message assigned to group	1 = Assign remote operator message to group
Assign to Group 3	377	0 = Remote operator message not assigned to group	0 = Unassign remote operator message from group
Assign to Group 4	378	1 = Remote operator message assigned to group	1 = Assign remote operator message to group
Assign to Group 5	379	0 = Remote operator message not assigned to group	0 = Unassign remote operator message from group
Assign to Group 6	380	1 = Remote operator message assigned to group	1 = Assign remote operator message to group
Activate remote operator message	381	Always reads as 0	0 = No effect 1 = Activate

Table B.8 Remote operator messages

MODBUS registers					
	Stop / Go	Reset	Wrap pulse	1st stage pulse	Flowrate failure
Read access	0 = Stopped 1 = Running	0 = >1s* 1 = <1s*	0 = Inactive 1 = Active	0 = Inactive 1 = Active	0 = Inactive 1 = Active
Write access	0 = Stop 1 = Start	1 = Reset			
Totalizer	MODBUS coil	MODBUS coil	MODBUS coil	MODBUS coil	MODBUS coil
1A	401	501	601	701	801
1B	402	502	602	702	802
2A	403	503	603	703	803
2B	404	504	604	704	804
3A	405	505	605	705	805
3B	406	506	606	706	806
4A	407	507	607	707	807
4B	408	508	608	708	808
5A	409	509	609	709	809
5B	410	510	610	710	810
6A	411	511	611	711	811
6B	412	512	612	712	812
7A	413	513	613	713	813
7B	414	514	614	714	814
8A	415	515	615	715	815
8B	416	516	616	716	816
9A	417	517	617	717	817
9B	418	518	618	718	818
10A	419	519	619	719	819
10B	420	520	620	720	820
11A	421	521	621	721	821
11B	422	522	622	722	822
12A	423	523	623	723	823
12B	424	524	624	724	824
13A	425	525	625	725	825
13B	426	526	626	726	826
14A	427	527	627	727	827
14B	428	528	628	728	828
15A	429	529	629	729	829
15B	430	530	630	730	830
16A	431	531	631	731	831
16B	432	532	632	732	832
17A	433	533	633	733	833
17B	434	534	634	734	834

Table B.9 Totalizer digital signals

		MODBUS registers				
		Stop / Go	Reset	Wrap pulse	1st stage pulse	Flowrate failure
Read access	0 = Stopped	0 = >1s*	0 = Inactive	0 = Inactive	0 = Inactive	
	1 = Running	1 = <1s*	1 = Active	1 = Active	1 = Active	
Write access	0 = Stop	1 = Reset				
	1 = Start					
Totalizer	MODBUS coil	MODBUS coil	MODBUS coil	MODBUS coil	MODBUS coil	
18A	435	535	635	735	835	
18B	436	536	636	736	836	
19A	437	537	637	737	837	
19B	438	538	638	738	838	
20A	439	539	639	739	839	
20B	440	540	640	740	840	
21A	441	541	641	741	841	
21B	442	542	642	742	842	
22A	443	543	643	743	843	
22B	444	544	644	744	844	
23A	445	545	645	745	845	
23B	446	546	646	746	846	
24A	447	547	647	747	847	
24B	448	548	648	748	848	

* Time since last reset

Table B.9 Totalizer digital signals (Continued)

Signal		Channel number / MODBUS coil											
		1	2	3	4	5	6	7	8	9	10	11	12
Channel Fail Status	Read only	1101	1201	1301	1401	1501	1601	1701	1801	1901	2001	2101	2201
Alarm A	Read only	1102	1202	1302	1402	1502	1602	1702	1802	1902	2002	2102	2202
Alarm B	Read only	1103	1203	1303	1403	1503	1603	1703	1803	1903	2003	2103	2203
Alarm C	Read only	1104	1204	1304	1404	1504	1604	1704	1804	1904	2004	2104	2204
Alarm D	Read only	1105	1205	1305	1405	1505	1605	1705	1805	1905	2005	2105	2205
Alarm A Acknowledge	Read / Write	1106	1206	1306	1406	1506	1606	1706	1806	1906	2006	2106	2206
Alarm B Acknowledge	Read / Write	1107	1207	1307	1407	1507	1607	1707	1807	1907	2007	2107	2207
Alarm C Acknowledge	Read / Write	1108	1208	1308	1408	1508	1608	1708	1808	1908	2008	2108	2208
Alarm D Acknowledge	Read / Write	1109	1209	1309	1409	1509	1609	1709	1809	1909	2009	2109	2209
Totalizer A Stop/Go	Read / Write	1110	1210	1310	1410	1510	1610	1710	1810	1910	2010	2110	2210
Totalizer A Reset	Read / Write	1111	1211	1311	1411	1511	1611	1711	1811	1911	2011	2111	2211
Totalizer A Wrap	Read only	1112	1212	1312	1412	1512	1612	1712	1812	1912	2012	2112	2212
Totalizer A First Stage	Read only	1113	1213	1313	1413	1513	1613	1713	1813	1913	2013	2113	2213
Totalizer A Flowrate Fail	Read only	1114	1214	1314	1414	1514	1614	1714	1814	1914	2014	2114	2214
Totalizer B Stop/Go	Read / Write	1115	1215	1315	1415	1515	1615	1715	1815	1915	2015	2115	2215
Totalizer B Reset	Read / Write	1116	1216	1316	1416	1516	1616	1716	1816	1916	2016	2116	2216
Totalizer B Wrap	Read only	1117	1217	1317	1417	1517	1617	1717	1817	1917	2017	2117	2217
Totalizer B First Stage	Read only	1118	1218	1318	1418	1518	1618	1718	1818	1918	2018	2118	2218
Totalizer B Flowrate Fail	Read only	1119	1219	1319	1419	1519	1619	1719	1819	1919	2019	2119	2219
Channel Type	Read only	1120	1220	1320	1420	1520	1620	1720	1820	1920	2020	2120	2220
Digital Value	Read only	1121	1221	1321	1421	1521	1621	1721	1821	1921	2021	2121	2221

Table B.10 Channel digital signals (channels 1 to 12)

Signal		Channel number / MODBUS coil											
		13	14	15	16	17	18	19	20	21	22	23	24
Channel Fail Status	Read only	2301	2401	2501	2601	2701	2801	2901	3001	3101	3201	3301	3401
Alarm A	Read only	2302	2402	2502	2602	2702	2802	2902	3002	3102	3202	3302	3402
Alarm B	Read only	2303	2403	2503	2603	2703	2803	2903	3003	3103	3203	3303	3403
Alarm C	Read only	2304	2404	2504	2604	2704	2804	2904	3004	3104	3204	3304	3404
Alarm D	Read only	2305	2405	2505	2605	2705	2805	2905	3005	3105	3205	3305	3405
Alarm A Acknowledge	Read / Write	2306	2406	2506	2606	2706	2806	2906	3006	3106	3206	3306	3406
Alarm B Acknowledge	Read / Write	2307	2407	2507	2607	2707	2807	2907	3007	3107	3207	3307	3407
Alarm C Acknowledge	Read / Write	2308	2408	2508	2608	2708	2808	2908	3008	3108	3208	3308	3408
Alarm D Acknowledge	Read / Write	2309	2409	2509	2609	2709	2809	2909	3009	3109	3209	3309	3409
Totalizer A Stop/Go	Read / Write	2310	2410	2510	2610	2710	2810	2910	3010	3110	3210	3310	3410
Totalizer A Reset	Read / Write	2311	2411	2511	2611	2711	2811	2911	3011	3111	3211	3311	3411
Totalizer A Wrap	Read only	2312	2412	2512	2612	2712	2812	2912	3012	3112	3212	3312	3412
Totalizer A First Stage	Read only	2313	2413	2513	2613	2713	2813	2913	3013	3113	3213	3313	3413
Totalizer A Flowrate Fail	Read only	2314	2414	2514	2614	2714	2814	2914	3014	3114	3214	3314	3414
Totalizer B Stop/Go	Read / Write	2315	2415	2515	2615	2715	2815	2915	3015	3115	3215	3315	3415
Totalizer B Reset	Read / Write	2316	2416	2516	2616	2716	2816	2916	3016	3116	3216	3316	3416
Totalizer B Wrap	Read only	2317	2417	2517	2617	2717	2817	2917	3017	3117	3217	3317	3417
Totalizer B First Stage	Read only	2318	2418	2518	2618	2718	2818	2918	3018	3118	3218	3318	3418
Totalizer B Flowrate Fail	Read only	2319	2419	2519	2619	2719	2819	2919	3019	3119	3219	3319	3419
Channel Type	Read only	2320	2420	2520	2620	2720	2820	2920	3020	3120	3220	3320	3420
Digital Value	Read only	2321	2421	2521	2621	2721	2821	2921	3021	3121	3221	3321	3421

Table B.11 Channel digital signals (channels 13 to 24)

B.5 Operating mode MODBUS registers

Tables B.12 to B.14 detail the contents of the MODBUS TCP registers accessible while the recorder is in the operating mode.

Two data types are used:

- 32-bit single precision floating point data in IEEE format
- 64-bit double precision floating point data in IEEE format

Note.

- When writing to a parameter that occupies more than one register position, all registers relating to that parameter **MUST** be written to as part of a multiple register write. If this is not achieved a NAK exception response is issued. Individual registers can be read without causing an exception response.
- When accessing a parameter that occupies more than one register position, the lowest numbered register contains the most significant data.

Read only, IEEE floating point 32 bit number							
Module A	MODBUS register	Module B	MODBUS register	Module C	MODBUS register	Module D	MODBUS register
A1	0001 and 0002	B1	0013 and 0014	C1	0025 and 0026	D1	0037 and 0038
A2	0003 and 0004	B2	0015 and 0016	C2	0027 and 0028	D2	0039 and 0040
A3	0005 and 0006	B3	0017 and 0018	C3	0029 and 0030	D3	0041 and 0042
A4	0007 and 0008	B4	0019 and 0020	C4	0031 and 0032	D4	0043 and 0044
A5	0009 and 0010	B5	0021 and 0022	C5	0033 and 0034	D5	0045 and 0046
A6	0011 and 0012	B6	0023 and 0024	C6	0035 and 0036	D6	0047 and 0048

Table B.12 Analog inputs

Read / Write, IEEE floating point 32 bit number							
Alarm	MODBUS registers	Alarm	MODBUS registers	Alarm	MODBUS registers	Alarm	MODBUS registers
1A	101 and 102	7A	149 and 150	13A	197 and 198	19A	245 and 246
1B	103 and 104	7B	151 and 152	13B	199 and 200	19B	247 and 248
1C	105 and 106	7C	153 and 154	13C	201 and 202	19C	249 and 250
1D	107 and 108	7D	155 and 156	13D	203 and 204	19D	251 and 252
2A	109 and 110	8A	157 and 158	14A	205 and 206	20A	253 and 254
2B	111 and 112	8B	159 and 160	14B	207 and 208	20B	255 and 256
2C	113 and 114	8C	161 and 162	14C	209 and 210	20C	257 and 258
2D	115 and 116	8D	163 and 164	14D	211 and 212	20D	259 and 260
3A	117 and 118	9A	165 and 166	15A	213 and 214	21A	261 and 262
3B	119 and 120	9B	167 and 168	15B	215 and 216	21B	263 and 264
3C	121 and 122	9C	169 and 170	15C	217 and 218	21C	265 and 266
3D	123 and 124	9D	171 and 172	15D	219 and 220	21D	267 and 268

Table B.13 Alarm trip values

Read / Write, IEEE floating point 32 bit number							
Alarm	MODBUS registers	Alarm	MODBUS registers	Alarm	MODBUS registers	Alarm	MODBUS registers
4A	125 and 126	10A	173 and 174	16A	221 and 222	22A	269 and 270
4B	127 and 128	10B	175 and 176	16B	223 and 224	22B	271 and 272
4C	129 and 130	10C	177 and 178	16C	225 and 226	22C	273 and 274
4D	131 and 132	10D	179 and 180	16D	227 and 228	22D	275 and 276
5A	133 and 134	11A	181 and 182	17A	229 and 230	23A	277 and 278
5B	135 and 136	11B	183 and 184	17B	231 and 232	23B	279 and 280
5C	137 and 138	11C	185 and 186	17C	233 and 234	23C	281 and 282
5D	139 and 140	11D	187 and 188	17D	235 and 236	23D	283 and 284
6A	141 and 142	12A	189 and 190	18A	237 and 238	24A	285 and 286
6B	143 and 144	12B	191 and 192	18B	239 and 240	24B	287 and 288
6C	145 and 146	12C	193 and 194	18C	241 and 242	24C	289 and 290
6D	147 and 148	12D	195 and 196	18D	243 and 244	24D	291 and 292

Table B.13 Alarm trip values (Continued)

Totalizer	Maximum flowrate (IEEE)	Minimum flowrate (IEEE)	Average flowrate (IEEE)	Batch total (double precision)	Batch total (IEEE)
1A	501 and 502	601 and 602	701 and 702	801 to 804	1001 and 1002
1B	503 and 504	603 and 604	703 and 704	805 to 808	1003 and 1004
2A	505 and 506	605 and 606	705 and 706	809 to 812	1005 and 1006
2B	507 and 508	607 and 608	707 and 708	813 to 816	1007 and 1008
3A	509 and 510	609 and 610	709 and 710	817 to 820	1009 and 1010
3B	511 and 512	611 and 612	711 and 712	821 to 824	1011 and 1012
4A	513 and 514	613 and 614	713 and 714	825 to 828	1013 and 1014
4B	515 and 516	615 and 616	715 and 716	829 to 832	1015 and 1016
5A	517 and 518	617 and 618	717 and 718	833 to 836	1017 and 1018
5B	519 and 520	619 and 620	719 and 720	837 to 840	1019 and 1020
6A	521 and 522	621 and 622	721 and 722	841 to 844	1021 and 1022
6B	523 and 524	623 and 624	723 and 724	845 to 848	1023 and 1024
7A	525 and 526	625 and 626	725 and 726	849 to 852	1025 and 1026
7B	527 and 528	627 and 628	727 and 728	853 to 856	1027 and 1028
8A	529 and 530	629 and 630	729 and 730	857 to 860	1029 and 1030
8B	531 and 532	631 and 632	731 and 732	861 to 864	1031 and 1032
9A	533 and 534	633 and 634	733 and 734	865 to 868	1033 and 1034
9B	535 and 536	635 and 636	735 and 736	869 to 872	1035 and 1036
10A	537 and 538	637 and 638	737 and 738	873 to 876	1037 and 1038
10B	539 and 540	639 and 640	739 and 740	877 to 880	1039 and 1040
11A	541 and 542	641 and 642	741 and 742	881 to 884	1041 and 1042
11B	543 and 544	643 and 644	743 and 744	885 to 888	1043 and 1044
12A	545 and 546	645 and 646	745 and 746	889 to 892	1045 and 1046
12B	547 and 548	647 and 648	747 and 748	893 to 896	1047 and 1048
13A	549 and 550	649 and 650	749 and 750	897 to 900	1049 and 1050
13B	551 and 552	651 and 652	751 and 752	901 to 904	1051 and 1052
14A	553 and 554	653 and 654	753 and 754	905 to 908	1053 and 1054

Table B.14 Totalizer totals (current batch)

Totalizer	Maximum flowrate (IEEE)	Minimum flowrate (IEEE)	Average flowrate (IEEE)	Batch total (double precision)	Batch total (IEEE)
14B	555 and 556	655 and 656	755 and 756	909 to 912	1055 and 1056
15A	557 and 558	657 and 658	757 and 758	913 to 916	1057 and 1058
15B	559 and 560	659 and 660	759 and 760	917 to 920	1059 and 1060
16A	561 and 562	661 and 662	761 and 762	921 to 924	1061 and 1062
16B	563 and 564	663 and 664	763 and 764	925 to 928	1063 and 1064
17A	565 and 566	665 and 666	765 and 766	929 to 932	1065 and 1066
17B	567 and 568	667 and 668	767 and 768	933 to 936	1067 and 1068
18A	569 and 570	669 and 670	769 and 770	937 to 940	1069 and 1070
18B	571 and 572	671 and 672	771 and 772	941 to 944	1071 and 1072
19A	573 and 574	673 and 674	773 and 774	945 to 948	1073 and 1074
19B	575 and 576	675 and 676	775 and 776	949 to 952	1075 and 1076
20A	577 and 578	677 and 678	777 and 778	953 to 956	1077 and 1078
20B	579 and 580	679 and 680	779 and 780	957 to 960	1079 and 1080
21A	581 and 582	681 and 682	781 and 782	961 to 964	1081 and 1082
21B	583 and 584	683 and 684	783 and 784	965 to 968	1083 and 1084
22A	585 and 586	685 and 686	785 and 786	969 to 972	1085 and 1086
22B	587 and 588	687 and 688	787 and 788	973 to 976	1087 and 1088
23A	589 and 590	689 and 690	789 and 790	977 to 980	1089 and 1090
23B	591 and 592	691 and 692	791 and 792	981 to 984	1091 and 1092
24A	593 and 594	693 and 694	793 and 794	985 to 988	1093 and 1094
24B	595 and 596	695 and 696	795 and 796	989 to 992	1095 and 1096

Table B.14 Totalizer totals (current batch) (Continued)

Totalizer	Maximum flowrate (IEEE)	Minimum flowrate (IEEE)	Average flowrate (IEEE)	Batch total (double precision)	Batch total (IEEE)
1A	1101 and 1102	1201 and 1202	1301 and 1302	1401 to 1404	1601 and 1602
1B	1103 and 1104	1203 and 1204	1303 and 1304	1405 to 1408	1603 and 1604
2A	1105 and 1106	1205 and 1206	1305 and 1306	1409 to 1412	1605 and 1606
2B	1107 and 1108	1207 and 1208	1307 and 1308	1413 to 1416	1607 and 1608
3A	1109 and 1110	1209 and 1210	1309 and 1310	1417 to 1420	1609 and 1610
3B	1111 and 1112	1211 and 1212	1311 and 1312	1421 to 1424	1611 and 1612
4A	1113 and 1114	1213 and 1214	1313 and 1314	1425 to 1428	1613 and 1614
4B	1115 and 1116	1215 and 1216	1315 and 1316	1429 to 1432	1615 and 1616
5A	1117 and 1118	1217 and 1218	1317 and 1318	1433 to 1436	1617 and 1618
5B	1119 and 1120	1219 and 1220	1319 and 1320	1437 to 1440	1619 and 1620
6A	1121 and 1122	1221 and 1222	1321 and 1322	1441 to 1444	1621 and 1622
6B	1123 and 1124	1223 and 1224	1323 and 1324	1445 to 1448	1623 and 1624
7A	1125 and 1126	1225 and 1226	1325 and 1326	1449 to 1452	1625 and 1626
7B	1127 and 1128	1227 and 1228	1327 and 1328	1453 to 1456	1627 and 1628
8A	1129 and 1130	1229 and 1230	1329 and 1330	1457 to 1460	1629 and 1630
8B	1131 and 1132	1231 and 1232	1331 and 1332	1461 to 1464	1631 and 1632
9A	1133 and 1134	1233 and 1234	1333 and 1334	1465 to 1468	1633 and 1634
9B	1135 and 1136	1235 and 1236	1335 and 1336	1469 to 1472	1635 and 1636
10A	1137 and 1138	1237 and 1238	1337 and 1338	1473 to 1476	1637 and 1638
10B	1139 and 1140	1239 and 1240	1339 and 1340	1477 to 1480	1639 and 1640
11A	1141 and 1142	1241 and 1242	1341 and 1342	1481 to 1484	1641 and 1642
11B	1143 and 1144	1243 and 1244	1343 and 1344	1485 to 1488	1643 and 1644

Table B.15 Totalizer totals (previous batch)

Totalizer	Maximum flowrate (IEEE)	Minimum flowrate (IEEE)	Average flowrate (IEEE)	Batch total (double precision)	Batch total (IEEE)
12A	1145 and 1146	1245 and 1246	1345 and 1346	1489 to 1492	1645 and 1646
12B	1147 and 1148	1247 and 1248	1347 and 1348	1493 to 1496	1647 and 1648
13A	1149 and 1150	1249 and 1250	1349 and 1350	1497 to 1500	1649 and 1650
13B	1151 and 1152	1251 and 1252	1351 and 1352	1501 to 1504	1651 and 1652
14A	1153 and 1154	1253 and 1254	1353 and 1354	1505 to 1508	1653 and 1654
14B	1155 and 1156	1255 and 1256	1355 and 1356	1509 to 1512	1655 and 1656
15A	1157 and 1158	1257 and 1258	1357 and 1358	1513 to 1516	1657 and 1658
15B	1159 and 1160	1259 and 1260	1359 and 1360	1517 to 1520	1659 and 1660
16A	1161 and 1162	1261 and 1262	1361 and 1362	1521 to 1524	1661 and 1662
16B	1163 and 1164	1263 and 1264	1363 and 1364	1525 to 1528	1663 and 1664
17A	1165 and 1166	1265 and 1266	1365 and 1366	1529 to 1532	1665 and 1666
17B	1167 and 1168	1267 and 1268	1367 and 1368	1533 to 1536	1667 and 1668
18A	1169 and 1170	1269 and 1270	1369 and 1370	1537 to 1540	1669 and 1670
18B	1171 and 1172	1271 and 1272	1371 and 1372	1541 to 1544	1671 and 1672
19A	1173 and 1174	1273 and 1274	1373 and 1374	1545 to 1548	1673 and 1674
19B	1175 and 1176	1275 and 1276	1375 and 1376	1549 to 1552	1675 and 1676
20A	1177 and 1178	1277 and 1278	1377 and 1378	1553 to 1556	1677 and 1678
20B	1179 and 1180	1279 and 1280	1379 and 1380	1557 to 1560	1679 and 1680
21A	1181 and 1182	1281 and 1282	1381 and 1382	1561 to 1564	1681 and 1682
21B	1183 and 1184	1283 and 1284	1383 and 1384	1565 to 1568	1683 and 1684
22A	1185 and 1186	1285 and 1286	1385 and 1386	1569 to 1572	1685 and 1686
22B	1187 and 1188	1287 and 1288	1387 and 1388	1573 to 1576	1687 and 1688
23A	1189 and 1190	1289 and 1290	1389 and 1390	1577 to 1580	1689 and 1690
23B	1191 and 1192	1291 and 1292	1391 and 1392	1581 to 1584	1691 and 1692
24A	1193 and 1194	1293 and 1294	1393 and 1394	1585 to 1588	1693 and 1694
24B	1195 and 1196	1295 and 1296	1395 and 1396	1589 to 1592	1695 and 1696

Table B.15 Totalizer totals (previous batch) (Continued)

B.6 Communications – analog and digital inputs

	Comms. digital inputs	Comms. analog input failure	Comms. analog inputs		Comms. digital inputs	Comms. analog input failure	Comms. analog inputs
	0 = Inactive 1 = Active		IEEE floating point		0 = Inactive 1 = Active		IEEE floating point
Input number	MODBUS coil	MODBUS coil	MODBUS register	Input number	MODBUS coil	MODBUS coil	MODBUS register
1	1001	1051	5001 and 5002	13	1013	1063	5025 and 5026
2	1002	1052	5003 and 5004	14	1014	1064	5027 and 5028
3	1003	1053	5005 and 5006	15	1015	1065	5029 and 5030
4	1004	1054	5007 and 5008	16	1016	1066	5031 and 5032
5	1005	1055	5009 and 5010	17	1017	1067	5033 and 5034
6	1006	1056	5011 and 5012	18	1018	1068	5035 and 5036
7	1007	1057	5013 and 5014	19	1019	1069	5037 and 5038
8	1008	1058	5015 and 5016	20	1020	1070	5039 and 5040
9	1009	1059	5017 and 5018	21	1021	1071	5041 and 5042
10	1010	1060	5019 and 5020	22	1022	1072	5043 and 5044
11	1011	1061	5021 and 5022	23	1023	1073	5045 and 5046
12	1012	1062	5023 and 5024	24	1024	1074	5047 and 5048

Table B.16 MODBUS inputs

			Recording channel – register number												
Parameter	R/W	Type	1	2	3	4	5	6	7	8	9	10	11	12	
Recording channel value	R	32 bit IEEEE	3001 and 3002	3051 and 3052	3101 and 3102	3151 and 3152	3201 and 3202	3251 and 3252	3301 and 3302	3351 and 3352	3401 and 3402	3451 and 3452	3501 and 3502	3551 and 3552	
Alarm A trip	R/W	32 bit IEEEE	3003 and 3004	3053 and 3054	3103 and 3104	3153 and 3154	3203 and 3204	3253 and 3254	3303 and 3304	3353 and 3354	3403 and 3404	3453 and 3454	3503 and 3504	3553 and 3554	
Alarm B trip	R/W	32 bit IEEEE	3005 and 3006	3055 and 3056	3105 and 3106	3155 and 3156	3205 and 3206	3255 and 3256	3305 and 3306	3355 and 3356	3405 and 3406	3455 and 3456	3505 and 3506	3555 and 3556	
Alarm C trip	R/W	32 bit IEEEE	3007 and 3008	3057 and 3058	3107 and 3108	3157 and 3158	3207 and 3208	3257 and 3258	3307 and 3308	3357 and 3358	3407 and 3408	3457 and 3458	3507 and 3508	3557 and 3558	
Alarm D trip	R/W	32 bit IEEEE	3009 and 3010	3059 and 3060	3109 and 3110	3159 and 3160	3209 and 3210	3259 and 3260	3309 and 3310	3359 and 3360	3409 and 3410	3459 and 3460	3509 and 3510	3559 and 3560	
Current batch	Totalizer A maximum flowrate	R	32 bit IEEEE	3011 and 3012	3061 and 3062	3111 and 3112	3161 and 3162	3211 and 3212	3261 and 3262	3311 and 3312	3361 and 3362	3411 and 3412	3461 and 3462	3511 and 3512	3561 and 3562
	Totalizer A minimum flowrate	R	32 bit IEEEE	3013 and 3014	3063 and 3064	3113 and 3114	3163 and 3164	3213 and 3214	3263 and 3264	3313 and 3314	3363 and 3364	3413 and 3414	3463 and 3464	3513 and 3514	3563 and 3564
	Totalizer A average flowrate	R	32 bit IEEEE	3015 and 3016	3065 and 3066	3115 and 3116	3165 and 3166	3215 and 3216	3265 and 3266	3315 and 3316	3365 and 3366	3415 and 3416	3465 and 3466	3515 and 3516	3565 and 3566
	Totalizer A batch total	R	64 bit IEEEE	3017 to 3020	3067 to 3070	3117 to 3120	3167 to 3170	3217 to 3220	3267 to 3270	3317 to 3320	3367 to 3370	3417 to 3420	3467 to 3470	3517 to 3520	3567 to 3570
Previous batch	Totalizer A maximum flowrate	R	32 bit IEEEE	3021 and 3022	3069 and 3070	3121 and 3122	3171 and 3172	3221 and 3222	3271 and 3272	3321 and 3322	3371 and 3372	3421 and 3422	3471 and 3472	3521 and 3522	3571 and 3572
	Totalizer A minimum flowrate	R	32 bit IEEEE	3023 and 3024	3071 and 3072	3123 and 3124	3173 and 3174	3223 and 3224	3273 and 3274	3323 and 3324	3373 and 3374	3423 and 3424	3473 and 3474	3523 and 3524	3573 and 3574
	Totalizer A average flowrate	R	32 bit IEEEE	3025 and 3026	3073 and 3074	3125 and 3126	3175 and 3176	3225 and 3226	3275 and 3276	3325 and 3326	3375 and 3376	3425 and 3426	3475 and 3476	3525 and 3526	3575 and 3576
	Totalizer A batch total	R	64 bit IEEEE	3027 to 3030	3075 to 3078	3127 to 3130	3177 to 3180	3227 to 3230	3277 to 3280	3327 to 3330	3377 to 3380	3427 to 3430	3477 to 3480	3527 to 3530	3577 to 3580

Table B.17 Channel data (channels 1 to 12)

				Recording channel – register number											
Parameter	R/W	Type	1	2	3	4	5	6	7	8	9	10	11	12	
Current batch	Totalizer B maximum flowrate	R	32 bit IEEE	3031 and 3032	3079 and 3080	3131 and 3132	3181 and 3182	3231 and 3232	3281 and 3282	3331 and 3332	3381 and 3382	3431 and 3432	3481 and 3482	3531 and 3532	3581 and 3582
	Totalizer B minimum flowrate	R	32 bit IEEE	3033 and 3034	3081 and 3082	3133 and 3134	3183 and 3184	3233 and 3234	3283 and 3284	3333 and 3334	3383 and 3384	3433 and 3434	3483 and 3484	3533 and 3534	3583 and 3584
	Totalizer B average flowrate	R	32 bit IEEE	3035 and 3036	3083 and 3084	3135 and 3136	3185 and 3186	3235 and 3236	3285 and 3286	3335 and 3336	3385 and 3386	3435 and 3436	3485 and 3486	3535 and 3536	3585 and 3586
	Totalizer B batch total	R	64 bit IEEE	3037 to 3040	3085 to 3088	3137 to 3140	3187 to 3190	3237 to 3240	3287 to 3290	3337 to 3340	3387 to 3390	3437 to 3440	3487 to 3490	3537 to 3540	3587 to 3590
Previous batch	Totalizer B maximum flowrate	R	32 bit IEEE	3041 and 3042	3089 and 3090	3141 and 3142	3191 and 3192	3241 and 3242	3291 and 3292	3341 and 3342	3391 and 3392	3441 and 3442	3491 and 3492	3541 and 3542	3591 and 3592
	Totalizer B minimum flowrate	R	32 bit IEEE	3043 and 3044	3091 and 3092	3143 and 3144	3193 and 3194	3243 and 3244	3293 and 3294	3343 and 3344	3393 and 3394	3443 and 3444	3493 and 3494	3543 and 3544	3593 and 3594
	Totalizer B average flowrate	R	32 bit IEEE	3045 and 3046	3093 and 3094	3145 and 3146	3195 and 3196	3245 and 3246	3295 and 3296	3345 and 3346	3395 and 3396	3445 and 3446	3495 and 3496	3545 and 3546	3595 and 3596
	Totalizer B batch total	R	64 bit IEEE	3047 to 3050	3095 to 3098	3147 to 3150	3197 to 3200	3247 to 3250	3297 to 3300	3347 to 3350	3397 to 3400	3447 to 3450	3497 to 3500	3547 to 3550	3597 to 3600

Table B.17 Channel data (channels 1 to 12) (Continued)

		Recording channel – register number													
Parameter	R/W	Type	13	14	15	16	17	18	19	20	21	22	23	24	
Recording channel value	R	32 bit IEEEE	3601 and 3602	3651 and 3652	3701 and 3702	3751 and 3752	3801 and 3802	3851 and 3852	3901 and 3902	3951 and 3952	4001 and 4002	4051 and 4052	4101 and 4102	4151 and 4152	
Alarm A trip	R/W	32 bit IEEEE	3603 and 3604	3653 and 3654	3703 and 3704	3753 and 3754	3803 and 3804	3853 and 3854	3903 and 3904	3953 and 3954	4003 and 4004	4053 and 4054	4103 and 4104	4153 and 4154	
Alarm B trip	R/W	32 bit IEEEE	3605 and 3606	3655 and 3656	3705 and 3706	3755 and 3756	3805 and 3806	3855 and 3856	3905 and 3906	3955 and 3956	4005 and 4006	4055 and 4056	4105 and 4106	4155 and 4156	
Alarm C trip	R/W	32 bit IEEEE	3607 and 3608	3657 and 3658	3707 and 3708	3757 and 3758	3807 and 3808	3857 and 3858	3907 and 3908	3957 and 3958	4007 and 4008	4057 and 4058	4107 and 4108	4157 and 4158	
Alarm D trip	R/W	32 bit IEEEE	3609 and 3610	3659 and 3660	3709 and 3710	3759 and 3760	3809 and 3810	3859 and 3860	3909 and 3910	3959 and 3960	4009 and 4010	4059 and 4060	4109 and 4110	4159 and 4160	
Current batch	Totalizer A maximum flowrate	R	32 bit IEEEE	3611 and 3612	3661 and 3662	3711 and 3712	3761 and 3762	3811 and 3812	3861 and 3862	3911 and 3912	3961 and 3962	4011 and 4012	4061 and 4062	4111 and 4112	4161 and 4162
	Totalizer A minimum flowrate	R	32 bit IEEEE	3613 and 3614	3663 and 3664	3713 and 3714	3763 and 3764	3813 and 3814	3863 and 3864	3913 and 3914	3963 and 3964	4013 and 4014	4063 and 4064	4113 and 4114	4163 and 4164
	Totalizer A average flowrate	R	32 bit IEEEE	3615 and 3616	3665 and 3666	3715 and 3716	3765 and 3766	3815 and 3816	3865 and 3866	3915 and 3916	3965 and 3966	4015 and 4016	4065 and 4066	4115 and 4116	4165 and 4166
	Totalizer A batch total	R	64 bit IEEEE	3617 to 3620	3667 to 3670	3717 to 3720	3767 to 3770	3817 to 3820	3867 to 3870	3917 to 3920	3967 to 3970	4017 to 4020	4067 to 4070	4117 to 4120	4167 to 4170
Previous batch	Totalizer A maximum flowrate	R	32 bit IEEEE	3621 and 3622	3671 and 3672	3721 and 3722	3771 and 3772	3821 and 3822	3871 and 3872	3921 and 3922	3971 and 3972	4021 and 4022	4071 and 4072	4121 and 4122	4171 and 4172
	Totalizer A minimum flowrate	R	32 bit IEEEE	3623 and 3624	3673 and 3674	3723 and 3724	3773 and 3774	3823 and 3824	3873 and 3874	3923 and 3924	3973 and 3974	4023 and 4024	4073 and 4074	4123 and 4124	4173 and 4174
	Totalizer A average flowrate	R	32 bit IEEEE	3625 and 3626	3675 and 3676	3725 and 3726	3775 and 3776	3825 and 3826	3875 and 3876	3925 and 3926	3975 and 3976	4025 and 4026	4075 and 4076	4125 and 4126	4175 and 4176
	Totalizer A batch total	R	64 bit IEEEE	3627 to 3630	3677 to 3680	3727 to 3730	3777 to 3780	3827 to 3830	3877 to 3880	3927 to 3930	3977 to 3980	4027 to 4030	4077 to 4080	4127 to 4130	4177 to 4180

Table B.18 Channel data (channels 13 to 24)

				Recording channel – register number											
	Parameter	R/W	Type	13	14	15	16	17	18	19	20	21	22	23	24
Current batch	Totalizer B maximum flowrate	R	32 bit IEEE	3631 and 3632	3681 and 3682	3731 and 3732	3781 and 3782	3831 and 3832	3881 and 3882	3931 and 3932	3981 and 3982	4031 and 4032	4081 and 4082	4131 and 4132	4181 and 4182
	Totalizer B minimum flowrate	R	32 bit IEEE	3633 and 3634	3683 and 3684	3733 and 3734	3783 and 3784	3833 and 3834	3883 and 3884	3933 and 3934	3983 and 3984	4033 and 4034	4083 and 4084	4133 and 4134	4183 and 4184
	Totalizer B average flowrate	R	32 bit IEEE	3635 and 3636	3685 and 3686	3735 and 3736	3785 and 3786	3835 and 3836	3885 and 3886	3935 and 3936	3985 and 3986	4035 and 4036	4085 and 4086	4135 and 4136	4185 and 4186
	Totalizer B batch total	R	64 bit IEEE	3637 to 3640	3687 to 3690	3737 to 3740	3787 to 3790	3837 to 3840	3887 to 3890	3937 to 3940	3987 to 3990	4037 to 4040	4087 to 4090	4137 to 4140	4187 to 4190
Previous batch	Totalizer B maximum flowrate	R	32 bit IEEE	3641 and 3642	3691 and 3692	3741 and 3742	3791 and 3792	3841 and 3842	3891 and 3892	3941 and 3942	3991 and 3992	4041 and 4042	4091 and 4092	4141 and 4142	4191 and 4192
	Totalizer B minimum flowrate	R	32 bit IEEE	3643 and 3644	3693 and 3694	3743 and 3744	3793 and 3794	3843 and 3844	3893 and 3894	3943 and 3944	3993 and 3994	4043 and 4044	4093 and 4094	4143 and 4144	4193 and 4194
	Totalizer B average flowrate	R	32 bit IEEE	3645 and 3646	3695 and 3696	3745 and 3746	3795 and 3796	3845 and 3846	3895 and 3896	3945 and 3946	3995 and 3996	4045 and 4046	4095 and 4096	4145 and 4146	4195 and 4196
	Totalizer B batch total	R	64 bit IEEE	3647 to 3650	3697 to 3700	3747 to 3750	3797 to 3800	3847 to 3850	3897 to 3900	3947 to 3950	3997 to 4000	4047 to 4050	4097 to 4100	4147 to 4150	4197 to 4200

Table B.18 Channel data (channels 13 to 24) (Continued)

Group 1		Group 2		Group 3	
Batch field	MODBUS registers	Batch field	MODBUS registers	Batch field	MODBUS registers
Batch number	2001 to 2020	Batch number	2101 to 2120	Batch number	2201 to 2220
Field 1	2026 to 2045	Field 1	2126 to 2145	Field 1	2226 to 2245
Field 2	2051 to 2070	Field 2	2151 to 2170	Field 2	2251 to 2270
Field 3	2076 to 2095	Field 3	2176 to 2195	Field 3	2276 to 2295

Group 4		Group 5		Group 6	
Batch field	MODBUS registers	Batch field	MODBUS registers	Batch field	MODBUS registers
Batch number	2301 to 2320	Batch number	2401 to 2420	Batch number	2501 to 2520
Field 1	2326 to 2345	Field 1	2426 to 2445	Field 1	2526 to 2545
Field 2	2351 to 2370	Field 2	2451 to 2470	Field 2	2551 to 2570
Field 3	2376 to 2395	Field 3	2476 to 2495	Field 3	2576 to 2595

Table B.19 Batch fields

Read / Write: ASCII Character Code – see Table B.21

Input	Register number	Input	Register number	Input	Register number
Character 1	2600	Character 8	2607	Character 15	2614
Character 2	2601	Character 9	2608	Character 16	2615
Character 3	2602	Character 10	2609	Character 17	2616
Character 4	2603	Character 11	2610	Character 18	2617
Character 5	2604	Character 12	2611	Character 19	2618
Character 6	2605	Character 13	2612	Character 20	2619
Character 7	2606	Character 14	2613		

Table B.20 Remote operator messages

Hex	Dec	Char	Hex	Dec	Char	Hex	Dec	Char	Hex	Dec	Char	Hex	Dec	Char
20	32	Space	34	52	4	47	71	G	5A	90	Z	6D	109	m
21	33	!	35	53	5	48	72	H	5B	91	[6E	110	n
22	34	"	36	54	6	49	73	I	5C	92	\	6F	111	o
23	35	#	37	55	7	4A	74	J	5D	93]	70	112	p
24	36	\$	38	56	8	4B	75	K	5E	94	^	71	113	q
25	37	%	39	57	9	4C	76	L	5F	95	_	72	114	r
26	38	&	3A	58	:	4D	77	M	60	96	N/A	73	115	s
27	39	`	3B	59	;	4E	78	N	61	97	a	74	116	t
28	40	(3C	60	<	4F	79	O	62	98	b	75	117	u
29	41)	3D	61	=	50	80	P	63	99	c	76	118	v
2A	42	*	3E	62	>	51	81	Q	64	100	d	77	119	w
2B	43	+	3F	63	?	52	82	R	65	101	e	78	120	x
2C	44	N/A	40	64	@	53	83	S	66	102	f	79	121	y
2D	45	-	41	65	A	54	84	T	67	103	g	7A	122	z
2E	46	.	42	66	B	55	85	U	68	104	h	7B	123	{
2F	47	/	43	67	C	56	86	V	69	105	i	7C	124	
30	48	0	44	68	D	57	87	W	6A	106	j	7D	125	}
31	49	1	45	69	E	58	88	X	6B	107	k	7E	126	~
32	50	2	46	70	F	59	89	Y	6C	108	l	7F	127	N/A
33	51	3												

Hex	Dec	Char
A3	163	£
B0	176	°
B2	178	²
B3	179	³
B5	181	µ
3A9	937	Ω

Note. Character codes 2C, 60 and 7F Hex (44, 96 and 127 Dec) are not supported

Table B.21 ASCII character set for remote operator messages

Appendix C – Storage capacity

C.1 Internal storage capacity – 256 MB flash memory

Approximate duration calculated for continuous recording of 6 channels of analog data (for example, for 12 channels divide by 2, for 24 channels divide by 4).

Sample rate	0.125 seconds	1 second	10 seconds	60 seconds	10 minutes	60 minutes
256 MB internal Flash memory	10 days	80 days	2.2 years	13 years	130 years	960 years

Table C.1 Internal storage capacity

C.2 Internal storage capacity – 2 GB flash memory

Approximate duration calculated for continuous recording of 24 channels of analog data (for example, for 12 channels multiply by 2, for 6 channels multiply by 4).

Sample rate	0.125 seconds	1 second	10 seconds	60 seconds	10 minutes	60 minutes
2 GB internal Flash memory	20 days	160 days	4.4 years	26 years	260 years	1920 years

Table C.2 Internal storage capacity

C.3 External storage capacity

Approximate duration calculated for continuous recording of 4 channels of analog data (for example, for 8 channels divide by 2; for 2 channels multiply by 2).

Sample rate	SD card size					
	256 MB	512 MB	1 GB	2 GB	4 GB	32 GB
1.0 second	6 months	12 months	2 years	4 years	8 years	64 years
10.0 seconds	5 years	10 years	20 years	40 years	80 years	640 years

Table C.3 External (archive) storage capacity

Appendix D – Units

Unit	Description
deg C	degrees Celsius
deg F	degrees Fahrenheit
Kelvin	degrees Kelvin
%RH	% Relative Humidity
%	%
ppm	parts per million
ppb	parts per billion
pH	potential Hydrogen
l/d	liters per day
l/h	liters per hour
l/m	liters per minute
l/s	liters per second
MI/d	megaliters per day
MI/h	megaliters per hour
MI/m	megaliters per minute
MI/s	megaliters per second
gal/d (UK)	imperial gallons per day
gal/h (UK)	imperial gallons per hour
gal/m (UK)	imperial gallons per minute
gal/s (UK)	imperial gallons per second
Mgal/d (UK)	imperial mega gallons per day
gal/d (US)	US gallons per day
gal/h (US)	US gallons per hour
gal/m (US)	US gallons per minute
gal/s (US)	US gallons per second
Mgal/d (US)	US mega gallons per day
m3/d	cubic meters per day
m3/h	cubic meters per hour
m3/m	cubic meters per minute
m3/s	cubic meters per second
ft3/d	cubic feet per day
ft3/h	cubic feet per hour
ft3/m	cubic feet per minute
ft3/s	cubic feet per second
SCFM	standard cubic feet per minute
kg/d	kilograms per day
kg/h	kilograms per hour
kg/m	kilograms per minute
kg/s	kilograms per second
T/d	metric tonnes per day
T/h	metric tonnes per hour
T/m	metric tonnes per minute
T/s	metric tonnes per second

Unit	Description
lb/d	pounds per day
lb/h	pounds per hour
lb/m	pounds per minute
lb/s	pounds per second
ton/d	imperial tons per day
ton/h	imperial tons per hour
ton/m	imperial tons per minute
ton/s	imperial tons per second
ug/kg	micrograms per kilogram
mg/kg	milligrams per kilogram
mbar	millibar
bar	bar
m WG	meters water gauge
Hz	hertz
kHz	kilohertz
% sat	% saturation
%O2	% oxygen
%N2	% nitrogen
%HCl	% hydrochloric acid
NTU	nephelometric turbidity units
FTU	formazine turbidity units
%OBS	% obscuration
g/l	grams per liter
g/h	grams per hour
g/d	grams per day
ml/m	milliliters per minute
ml/h	milliliters per hour
%dO2	% dissolved oxygen
uV	microvolts
mV	millivolts
MV	megavolts
A	amps
mho	conductance
S	Siemens
uS/cm	microSiemens per centimeter
mS/cm	milliSiemens per centimeter
uS/m	microSiemens per meter
mS/m	milliSiemens per meter
Feet	imperial feet
Inches	imperial inches
psi	ponds per square inch
Custom	user defined units

Table D.1 Engineering units

Unit	Description
l	liters
ml	milliliters
kl	kiloliters
Ml	megaliters
m	meters
gal (UK)	imperial gallons
g x 10 (UK)	imperial gallons x 10
g x100 (UK)	imperial gallons x 100
kgal (UK)	imperial kilo gallons
Mgal (UK)	imperial mega gallons
gal (US)	US gallons
g x 10 (US)	US gallons x 10
g x100 (US)	US gallons x 100
kgal (US)	US kilo gallons
Mgal (US)	US mega gallons

Unit	Description
m ³	cubic meters
km ³	kilo cubic meters
Mm ³	mega cubic meters
CUMEC	cubic meter of water per second
kg	kilograms
T	tons
kT	kilotons
lb	pounds
ton	imperial tons
btu	british thermal units
ft ³	cubic feet
kft ³	kilo cubic feet
Mft ³	mega cubic feet
AcreFt	volume of water, 1ft deep, covering an area of 1 acre
Custom	user defined units

Table D.2 Totalizer units

Appendix E – Batch recording

Note. The batch recording tabs are displayed only if the Batch option is enabled.

E.1 Introduction

The recorder's batch recording function enables:

- storage of archived data in batch format
- the operator to identify the batch data by name and / or number
- the operator to enter essential batch information that is then recorded with the data
- the operator to start and stop batch recording from the front panel or via remote signals
- the operator to archive the internally-recorded values so that the data for each batch can be retrieved easily and reviewed
- the retrieval of data from the recorder based on its batch identity

In addition, using the Company's DataManager Pro data analysis software package, batched data can be located and retrieved using its batch identity



A **Batch Log** archive file is created that contains all the identification data for each batch. Its filename is formatted as described in Table 6.2 on page 56.

The **Alarm Event Log** archive files also contain details of all batch start and stop events.

E.2 Operation

E.2.1 Overview

Batch recording can be started and stopped either automatically, using a digital signal source (see page 178), or manually from any of the vertical or horizontal chart view operator menus.

Batch start and stop events are recorded in the alarm event log. The  icon is displayed in the log when a batch is started and the  icon is displayed when a batch is stopped. If **Field 1** is defined during configuration (see page 179) and the operator has entered text in the field (see next page), that text is displayed in the **Event Tag** field of the Alarm Event log. The batch number or label is displayed in the **Source Tag** field. The date and time of the event are also displayed.

If **Chart Annotation** is enabled, batch start and stop events are also displayed in the selected chart view in the format <icon> <time> <Field 1 text> <batch no.>, for example:

 16:56:00 195_R13 Energy Tyre 14 .

E.2.2 Starting a batch manually

Note. A batch can be started only from the vertical- or horizontal-chart view operator menus. Touch  to open the menu.



Touch to display the Operator menu



Start Batch

Note. Greyed out if batch recording has not been enabled during Group configuration **or** a batch is running.

Touch to start batch recording. A dialog box is displayed to enable the operator to edit the batch details.

Note. If **Security system** is set to *Advanced* (see Section E.3.1, page 177) **and** the operator has the necessary access rights (see Section E.3.2, page 177) **and Operator login** is set to *Start* or *Start and Stop* (see page 178), a password entry dialog box is displayed. The correct operator password must be entered to enable the batch to be started.

New Batch

Batch Number



Enter or edit the batch number or label.

If **Batch Number** is set to *Automatic* during configuration (see page 179), this field increments automatically by one each time a batch is started. A number entry pad is displayed when the edit button is selected to enable the batch number to be edited manually.

If **Batch Number** is set to *Off* during configuration, this field is blank. A number entry pad is displayed when the edit button is selected to enable a batch number to be entered manually.

If **Batch Number** is set to *Text* during configuration, this field is blank. A text entry keyboard is displayed when the edit button is selected to enable a batch label to be entered manually (maximum 20 characters).

Note. Batch information can also be entered easily into the recorder using a USB barcode scanner or keyboard.

Field 1	Note. These fields are editable only if defined during configuration – see page 179.
Field 2	
Field 3	
	Touch the relevant  button to modify each field. A list box is displayed to enable to operator to either select a previously defined entry (maximum 10) or to define a new entry (maximum 18 characters per field).
	Note. Batch information can also be entered easily into the recorder using a USB barcode scanner or keyboard.
Operator	The operator's name is displayed if Operator login is not set to Disabled – see page 178.
	Touch  to accept changes and start batch recording. Touch  to return to the chart view without starting batch recording.

E.2.3 Stopping a batch manually

Note. A batch can be stopped only from the vertical or horizontal chart view operator menus. Touch  to open the menu.





Touch to display the Operator menu



Stop Batch

Note. Greyed out if batch recording has not been enabled during Group configuration **or** a batch is not running.

Touch to stop batch recording. A confirmation dialog box is displayed. Touch  to stop the batch or  to allow the batch to continue.

Note. If Security system is set to *Advanced* (see Section E.3.1, page 177) **and** the operator has the necessary access rights (see Section E.3.2, page 177) **and** Operator login is set to *Start and Stop* (see page 178), a password entry dialog box is displayed. The correct operator password must be entered to enable the batch to be started.

E.2.4 Historical review

If the recorder is in historical review mode, any previously recorded batch can be reviewed providing the data is still in internal memory.



Touch to display the Operator menu



Historical Review

Touch to display the sub-menu.



Select Batch

Touch to move to data recorded in the recorder's onboard memory for a specific batch.

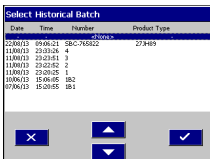

Date	Time	Number	Product Type
11/06/12	09:05:21	SBC-716522	273469
11/06/12	23:03:06	4	
11/06/12	23:03:51	3	
11/06/12	23:03:52	2	
11/06/12	23:03:52	1	
10/06/12	15:06:05	082	
07/06/12	15:01:05	081	

Select the batch to be reviewed from the list.

The data is displayed from the start of the batch.

E.3 Configuration

E.3.1 Enabling batch security

Note. Batch security can be enabled only if the **Security system** parameter is set to **Advanced** – see Section 7.7.5, page 74. If the **Security system** parameter is set to **Basic**, batch security is automatically disabled and cannot be enabled.

To enable batch security, access Common Configuration (see Section 7.7.5, page 74) and select the **Security** tab.

Security

Security type	Set the Security type.
Security system	Set to <i>Advanced</i> to enable batch security.

E.3.2 Configuring batch access privileges

To enable operators to manually control batches, access Common Configuration (see Section 7.7.6, page 76) and select the **User** tab.

User

User 1 Name	Configure User 1 (System Administrator)
User 1 Access	Ensure Batch is ticked to enable User 1 to start and stop batches – see Section E.2, page 174. Repeat as required for other users. Refer to page 178 to set the required type of batch recording security.

E.3.3 Batch configuration

To configure batch recording, access Process Group Configuration (see Section 7.8, page 80), select the required Process Group and select the **Batch** tab. Exit and save the configuration when complete.

Batch

Enable Batch Recording

Enable Batch Recording Set to *On* to enable batch recording for the selected process group.

Note. The following parameters are displayed only if **Enable Batch Recording** is set to *On*.

Batch Type Touch  to toggle between *Standard* and *Concurrent*.

Start/Stop, Abort

Start/Stop Batch Source Select a digital signal source to start batch recording on a rising edge and stop batch recording on a falling edge.

Note. If **Batch Number** (see next page) is set to *Off* or *Text* and a batch is started using a digital signal, the contents of the **Batch Number** and batch identification fields (if configured – see next page) are copied automatically to the new batch. If **Batch Number** is set to *Automatic*, the content of the **Batch Number** field is incremented by one, automatically.

Batch Power Failure Select a time between 1 minute and 2 hours to enable this function or select *Off* to disable it.

If this function is enabled and electrical power is lost for more than the time selected, the batch is stopped and a digital **Batch Power Failure** signal is activated for 5 seconds.

Note. The value selected affects all groups. The default value is *Off*.

Operator Login

Select the type of batch recording security required:

- Start* – the operator is required to enter a password to start batch recording.
- Start and Stop* – the operator is required to enter a password to start and stop batch recording.
- Disabled* – batch recording security is disabled.

Note.

- Batch recording security can be enabled only if **Security system** is set to *Advanced* (see Section E.3.1, page 177). If **Security system** is set to *Basic* this parameter is set automatically to *Disabled* and the edit button is not displayed.
- If this parameter is set to *Disabled* no security is required to start or stop batch recording and the operator name is not displayed.

Batch Number	Select the required batch numbering system: <i>Automatic</i> – the batch number increments automatically when a new batch is started, up to a maximum batch number of 9,999,999,999. <i>Off</i> – a batch number is not assigned automatically but may be entered manually by the operator. <i>Text</i> – enables the operator to identify the batch with a text string (maximum 10 characters).
---------------------	---

Note. If set to *Automatic* or *Off*, this parameter enables the operator to enter a batch number when starting a batch from the operator menu – see Section E.2.2, page 174.

Field 1 Title	Enter up to 3 identifying labels for the batch, maximum 20 characters per field.
Field 2 Title	
Field 3 Title	

Note.

- Configured fields are shown on the **New Batch** dialog box that is displayed when the operator starts a batch from the operator menu. This enables the operator to enter further details to identify the batch both on the recorder and when analyzing the archived data using DataManager Pro software.
- It is important to configure Field 1 because it is used, together with the batch number, to identify a batch:
 - on chart annotations
 - in the alarm event log
 - during historical review
 - in the DataManager Pro display / search functions

Appendix F – Character entry

When using the new QWERTY keyboard the following characters are available for all text data entry:

a to z, A to Z, 0 to 9, ' ' [] { } () + - ' = ' _ ^ ' " # ' & ' ; ' ! ' @ ' % ' \$ ' .

'Special' characters '€' '¥' '£' '¢' '¤' '¥' '¦' '§' '¨' '©' 'ª' '«' '¬' '®' '¯' '°' '±' '²' '³' '´' 'µ' are also available but, to comply with standard MS Windows filenames convention, their use is prevented in file names and any text that is displayed in log views. Therefore, special characters are not permitted in:

- Configuration level
 - Instrument tag
 - Group recording tag
 - Batch field 1 title
 - Batch field 2 title
 - Batch field 3 title
 - Usernames
 - Operator messages
- Operator views
 - New batch dialog **Batch number** and **Batch field 1 to 3** entries
 - User-defined operator message
 - Chart signatures

Language-specific characters (for example, ç, á, â, ã, ä, å, ì, ñ, ö, ß etc.) are not supported.

These limitations also apply to the scanner and PC emulation. If invalid characters are scanned in or typed in using the keyboard, the user is warned that invalid characters have been detected and are being replaced by the underscore '_' character.

No other characters can be entered using the recorder's keyboard or scanner or PC emulation. Web browser users do not have any limits applied and may not need any.

Note.

- Tags with a high percentage of capital letters and wide characters such as 'W' or 'M' may appear truncated in some Operator views. In such cases, use lower case letters or fewer characters.
- The superscript 3 (³) may not be displayed correctly in all Operator view configurations. If used, check that it is displayed correctly.

Index

A	
Access privileges	78
Accessing the configuration level	60
Advanced security – see Security system: Advanced	
Alarm Event log	34, 38, 40, 43
Archive file types	55
Archive filename format	56
Filter	47
Alarms	30
Acknowledge timeout	101
Acknowledging	38, 68, 83, 85
Access privileges	77, 78
Annunciate	96, 99
Delayed process	100
Groups	101
Hysteresis	78, 99
Latch	95, 99
Process	95, 99
Rate	97, 100
Real-time	128
State recording	101
Tag	99
Type	99
Analog inputs	91
24 V digital input	90
Volt-free digital input	90
Archive file types	55
Archiving	
Archive wrap	58, 70
Data file examples	57
Data verification and integrity	57
Filenames	56
Log files	56
Media type selection	70
On-line / Off-line	52, 58
Reset	53
Sample rates	55
Assign to group	
Electronic signatures	48
Audit log	36, 55
B	
Bargraph	8, 32, 37
Enabling	84
Max / Min reset	85
View	32
Batch access privileges	78, 177
Batch recording	85, 174 to 179

C

Channel indicator	
Tags	93, 94
Chart	
Annotation	43, 82
Electronic signatures	48
Scales	40, 43, 83
Logarithmic	88
Traces	30, 43, 83, 86
Views	
Horizontal	26, 28
Vertical	26, 28
Zoning	86
Chart view timer	71
Configuration	
Alarms	95 to 101
Analog input	90 to 93, 112 to 113
Electrical range	91
Engineering range	92
Input failure	93, 136
Channel	86 to 107
Chart view	82 to 83
Common	68 to 79
Custom linearizers	127
Data entry dialog boxes	65
Digital input	94
Exiting configuration mode	66
Fo value calculation	108 to 111
I/O modules	112 to 113
Analog inputs	112
Ethernet module	117
Relay modules	114, 115
RS485 (MODBUS) modules	126
Indicator view	84, 85
Locating parameter settings	64
Number of groups	68
Operator messages	79
Overview	63
Process group	80 to 85
Real time alarms	128
Recording channel setup	86 to 87
Recording parameters	80 to 81
Sample rates	81
Security	59, 74 to 75
Access privileges	78
Inactive user de-activation	75
Passwords	75
Type	74
View / Edit other users	76, 77, 177
Totalizers	102 to 107

D	
Datamanager Pro	57, 173, 179
Date and time	72 to 73
Daylight saving	41, 73
Delayed process alarms	98
Digital inputs	
24 V digital input	94
Volt-free digital input	94
Displays and controls	24
E	
Electrical installation	
Connections	16
AC and DC power supply connections	19
Analog / Digital input connections	18
Volt-free digital input	17
Fuses	14, 19
Relays	21
Thermocouple compensating cable	18
Electronic signatures – see Chart: Electronic signatures	
Engineering units	93, 171
Ethernet	117
F	
F ₀ value calculation	108
Cut off value	111
Preset count	110
Tag	109
Wrap	108
File viewer	53
Filter	
Recording channel input	87
Filter time	93
Functional overview	8
Functions	127 to 128
H	
Historical review	39, 40, 41, 42, 52, 53, 174, 176
Enable	83
Exit	40
Goto	41

I

Indicator	
Show statistics / totalizers	46
View	31
Adding alarm trip point indicators to bargraph	84
Bargraph display	84
Enabling menu items	84, 85
Totalizer	84
Input adjustment	46, 78, 112
From Service menu	113
See also Configuration: Analog input: Input adjustment	
Input calibration	112
Operator calibrate	113
Sensor calibration	113
Input type	90
Installation	13
Environmental limits	11
Mounting dimensions	12
Instrument tag	44, 69, 72, 180

L

Language	68
Linearizer type	90
Linearizer units	90
Logging	
Channel data files	52
Logging access	
Advanced security	50
Basic security	49
Logging level	
Menu	52

M

MODBUS (RS485) 126
 Address 126, 127
 Baud rate 126
 Parity 126
 Poll fail limit 126
 Poll rate 126
 Response timeout 126
MODBUS TCP 121 to 122, 149
 Alarm groups 154
 Any alarm 154
 Character set for remote operator messages 169
 Commands 149
 Exception responses 150
 Modbus inputs 164
 Operator messages 154
 Real-time alarms 154
 Remote operator messages 155, 169
 Reverse IEEE data 121
 Server (MODBUS slave) 123
 TCP client access 123
 TCP/IP port 121

O

Operator displays – navigating 25
Operator messages
 Alarm event log 47
 Chart view 39, 82, 83
 User defined 39
Overview display 33, 37
 Enabling 71
 Operator menu 43, 44, 46

P

Panel-mounting 13
Password entry 51
Passwords
 Entry failure limit 75
 Expiry 75
 Length 75
Primary and secondary sample rates 42, 53, 55, 81
Process group tag 80

R

Real-time alarms 128
Recording parameters 80 to 81
Relays 21
Reset archiving – see Archiving: Reset
Resistance thermometer (RTD) 90, 92

S

Sample rates	30, 42, 53, 55, 83
<i>See also</i> Primary and secondary sample rates	
Scale type	88
Scales – <i>see</i> Chart: Scales	
Screen capture	71
Screen interval	53, 83
Select enable	83
Screen saver	71
Security	
Options	74
Reconfigure preset password	75
Security switch – setting	62
Security system	
Advanced	74, 76
Basic	74, 76
Setup level	
Recording control	53
Signal sources	146
Simulated inputs	90
Storage capacity	
External	170
Internal	170
System administrator	74, 75

T

Thermocouple compensating cable	18, 113
Totalizer log	35
F ₀ values update frequency	110
Update frequency	105
Totalizers	
Count direction	102
Count rate	106
F ₀ value calculation	108
Preset count	104
Tag	103
Units	103, 172
Wrap	102
Touchscreen	8, 24, 37
Gestures	25
Trace	
Width	83

Acknowledgements and trademarks

Microsoft is a registered trademark of Microsoft Corporation in the United States and/or other countries.

MODBUS is a registered trademark of the Modbus-IDA organization.

Products and customer support

Automation Systems

For the following industries:

- Chemical & Pharmaceutical
- Food & Beverage
- Manufacturing
- Metals and Minerals
- Oil, Gas & Petrochemical
- Pulp and Paper

Drives and Motors

- AC and 6 Drives, AC and DC Machines, AC Motors to 1kV
- Drive Systems
- Force Measurement
- Servo Drives

Controllers & Recorders

- Single and Multi-loop Controllers
- Circular Chart and Strip Chart Recorders
- Paperless Recorders
- Process Indicators

Flexible Automation

- Industrial Robots and Robot Systems

Flow Measurement

- Electromagnetic Flowmeters
- Mass Flowmeters
- Turbine Flowmeters
- Wedge Flow Elements

Marine Systems & Turbochargers

- Electrical Systems
- Marine Equipment
- Offshore Retrofit and Refurbishment

Process Analytics

- Process Gas Analysis
- Systems Integration

Transmitters

- Pressure
- Temperature
- Level
- Interface Modules

Valves, Actuators and Positioners

- Control Valves
- Actuators
- Positioners

Water, Gas & Industrial Analytics Instrumentation

- pH, Conductivity and Dissolved Oxygen Transmitters and Sensors
- Ammonia, Nitrate, Phosphate, Silica, Sodium, Chloride, Fluoride, Dissolved Oxygen and Hydrazine Analyzers
- Zirconia Oxygen Analyzers, Katharometers, Hydrogen Purity and Purge-gas Monitors, Thermal Conductivity

Customer support

We provide a comprehensive after sales service via a Worldwide Service Organization. Contact one of the following offices for details on your nearest Service and Repair Centre.

UK

ABB Limited
Tel: +44 (0)1480 475321
Fax: +44 (0)1480 217948

USA

ABB Inc.
Tel: +1 215 674 6000
Fax: +1 215 674 7183

India

ABB Limited
Tel: +91 129 2448300
Fax: +91 129 2440622

Client Warranty

Prior to installation, the equipment referred to in this manual must be stored in a clean, dry environment, in accordance with the Company's published specification.

Periodic checks must be made on the equipment's condition. In the event of a failure under warranty, the following documentation must be provided as substantiation:

- A listing evidencing process operation and alarm logs at time of failure.
- Copies of all storage, installation, operating and maintenance records relating to the alleged faulty unit.

Contact us

ABB Limited

Process Automation

Howard Road

St. Neots

Cambridgeshire PE19 8EU

UK

Tel: +44 (0)1480 475321

Fax: +44 (0)1480 217948

ABB Inc.

Process Automation

125 E. County Line Road

Warminster

PA 18974

USA

Tel: +1 215 674 6000

Fax: +1 215 674 7183

ABB Limited

Process Automation

32, Industrial Area, N.I.T.

Faridabad-121001 (Haryana)

India

Tel: +91 129 2448300

Fax: +91 129 2440622

www.abb.com/recorders

Note

We reserve the right to make technical changes or modify the contents of this document without prior notice. With regard to purchase orders, the agreed particulars shall prevail. ABB does not accept any responsibility whatsoever for potential errors or possible lack of information in this document.

We reserve all rights in this document and in the subject matter and illustrations contained therein. Any reproduction, disclosure to third parties or utilization of its contents in whole or in parts – is forbidden without prior written consent of ABB.

Copyright© 2013 ABB

All rights reserved

3KXR110200R4201

O1/RVG200-EN 10.2013