

## High efficiency synchronous step-down regulator based on the L6984

Data brief



### Description

The STEVAL-ISA159V1 product evaluation board is based on a high-efficiency monolithic synchronous step-down regulator, capable of delivering up to 400 mA of DC current. The fixed 3.3 V output requires no external resistor divider. The Low Consumption Mode (LCM) is designed for applications active during car parking, so it maximizes the efficiency at light load with controlled output voltage ripple. The Low Noise Mode (LNM) makes the switching frequency nearly constant over the load current range, serving low noise application specifications such as car audio/sensors. The PGOOD open collector output can implement output voltage sequencing during the power-up phase. The synchronous rectification, designed for high efficiency at medium-heavy load, and the high switching frequency capability ensure a compact application size. Pulse-by-pulse current sensing on the low-side power element implements effective constant current protection.

### Features

- 400 mA DC output current
- 4.5 V to 36 V operating input voltage
- Synchronous rectification
- Low consumption mode or low noise mode
- 100  $\mu$ A  $I_Q$  at light load (LCM  $V_{OUT} = 3.3$  V)
- 13  $\mu$ A  $I_{Q-SHTDWN}$
- Adjustable  $f_{SW}$  (250 kHz - 600 kHz)
- Output voltage adjustable from 0.9 V
- No resistor divider required for 3.3 V  $V_{OUT}$
- $V_{BIAS}$  maximizes efficiency at light load
- 350 mA valley current limit
- Constant on-time control scheme
- PGOOD open collector
- Thermal shutdown

# 1 Schematic diagram

Figure 1: STEVAL-ISA159V1 circuit schematic

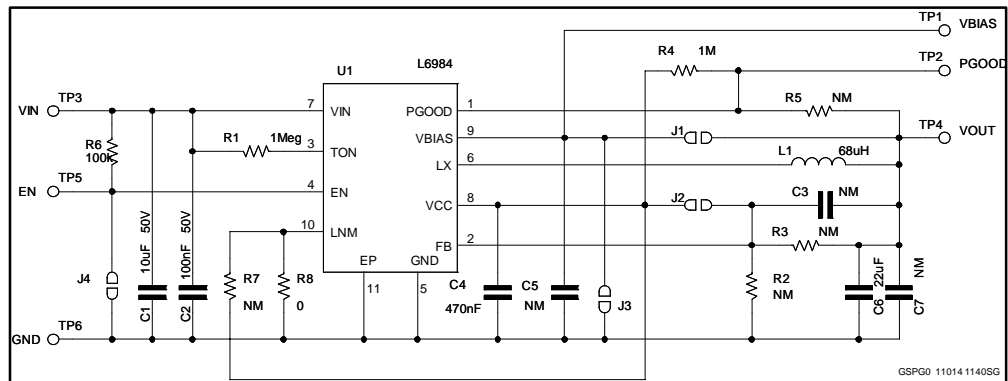

## 2 Revision history

Table 1: Document revision history

Data	Revision	Changes
03-Oct-2014	1	Initial release

**IMPORTANT NOTICE – PLEASE READ CAREFULLY**

STMicroelectronics NV and its subsidiaries ("ST") reserve the right to make changes, corrections, enhancements, modifications, and improvements to ST products and/or to this document at any time without notice. Purchasers should obtain the latest relevant information on ST products before placing orders. ST products are sold pursuant to ST's terms and conditions of sale in place at the time of order acknowledgement.

Purchasers are solely responsible for the choice, selection, and use of ST products and ST assumes no liability for application assistance or the design of Purchasers' products.

No license, express or implied, to any intellectual property right is granted by ST herein.

Resale of ST products with provisions different from the information set forth herein shall void any warranty granted by ST for such product.

ST and the ST logo are trademarks of ST. All other product or service names are the property of their respective owners.

Information in this document supersedes and replaces information previously supplied in any prior versions of this document.

© 2014 STMicroelectronics – All rights reserved