

Modular Electric Actuators OSP-E

ORIGA SYSTEM PLUS

aerospace
climate control
electromechanical
filtration
fluid & gas handling
hydraulics
pneumatics
process control
sealing & shielding



ENGINEERING YOUR SUCCESS.

Versions

– For electric Actuator:
Series OSP-E Belt
Series OSP-E Screw

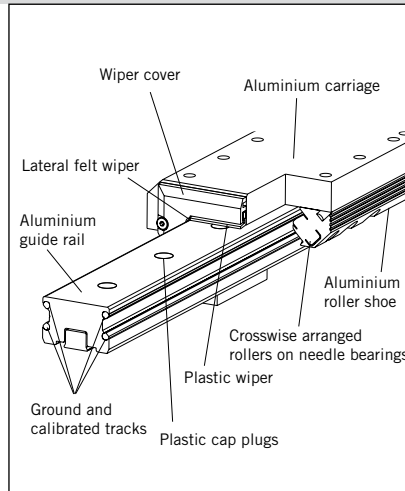
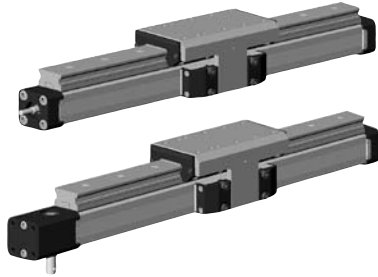

PROLINE Aluminium Roller Guide

OSP
— ORIGA
— SYSTEM
— PLUS

Series PL 25 to 50
for Actuator

- Series OSP-E Belt *
- Series OSP-E Screw

Technical Data

The table shows the maximum permissible loads. If multiple moments and forces act upon the cylinder simultaneously, the following equation applies:

$$\frac{F_y}{F_{y_{\max}}} + \frac{F_z}{F_{z_{\max}}} + \frac{M_x}{M_{x_{\max}}} + \frac{M_y}{M_{y_{\max}}} + \frac{M_z}{M_{z_{\max}}} \leq 1$$

The table shows the maximum permissible values for light, shock-free operation, which must not be exceeded even under dynamic conditions.

With a load factor of < 1, the service life is 5000 km.
The sum of the loads must not exceed >1

Features:

- High precision
- High velocities (10 m/s)
- Smooth operation - low noise
- Integrated wiper system
- Compact dimensions - compatible to Slideline plain bearing guide
- Stainless steel version available on request
- Any length of stroke up to 3750 mm
The maximum stroke lengths of actuators OSP-E..B, OSP-E..SB and OSP-E..ST must be observed

Loads, Forces and Moments

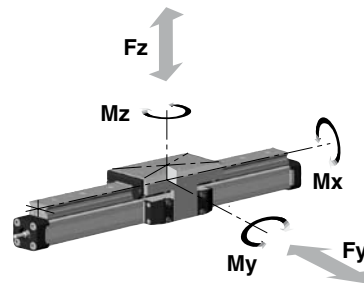

* Series PL for OSP-E Bi-parting version on request

Series	Max. Moments [Nm]			Max. Load [N]	Mass of drive with guide [kg]				Mass guide-carriage [kg]	Order No. PROLINE ¹⁾ for	
	Mx	My	Mz		Fy, Fz	OSP-E Belt	OSP-E Screw	increase per 100 mm stroke		OSP-E Belt	OSP-E Screw
PL 25	19	44	44	986	1.9	1.8	0.33	0.40	0.75	20874	20856
PL 32	33	84	84	1348	3.6	3.7	0.58	0.70	1.18	20875	20857
PL 50	128	287	287	3582	8.9	8.8	1.00	1.32	2.50	20876	20859

¹⁾ Stainless steel version on request

For Mountings see page 149

Dimensions Series OSP-E Belt PL25, PL32, PL50

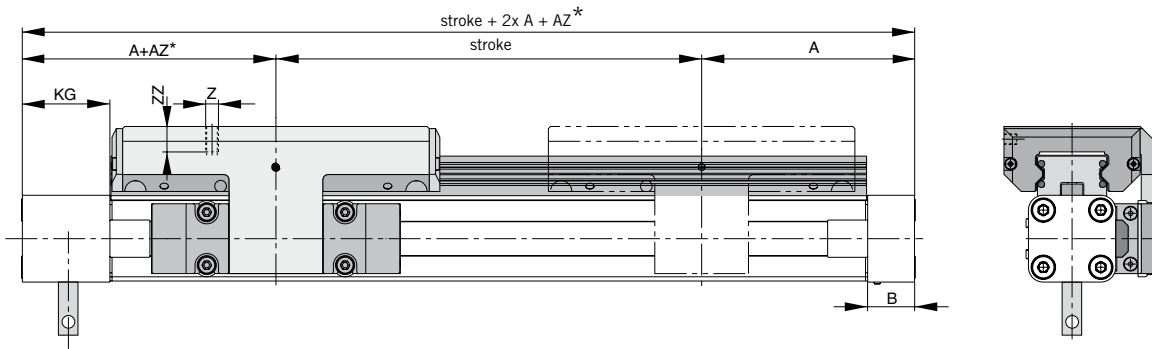

*** Please observe:**
 Dimension "AZ" must be added to dimension "A". The stroke to be ordered will be: stroke + min. dimension "AZ" + additional length.
 Please observe the effect of dimension "AZ" when retrofitting a guide. Please contact our application engineers.

Dimension Table [mm] Series OSP-E Belt PL25, PL32, PL50

Series	A	B	J	M	Z	AA	AZ	BB	DD	CF	EC	EE	EG	FF	FS	FT	GG	JJ	KG	ZZ
PL25	125	22	117	40,5	M6	154	10	144	60	72.5	32.5	53	39	64	23	73.5	50	120	57	12
PL32	150	25	152	49	M6	197	11	187	80	91	42	62	48	84	25	88	64	160	61	12
PL50	200	25	200	62	M6	276	24	266	120	117	63	75	57	110	29	118.5	90	240	85	16

Dimensions Series OSP-E Screw PL25, PL32, PL50

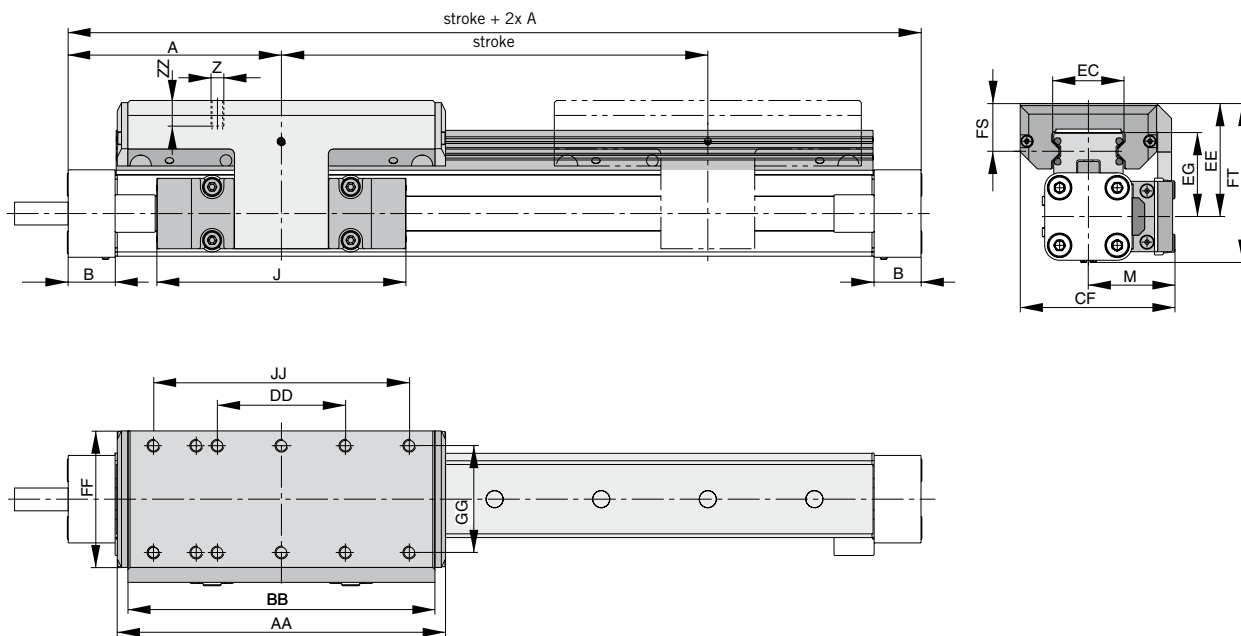

Dimension Table [mm] OSP-E Screw PL25, PL32, PL50

Series	A	B	J	M	Z	AA	BB	DD	CF	EC	EE	EG	FF	FS	FT	GG	JJ	ZZ
PL25	100	22	117	40.5	M6	154	144	60	72.5	32.5	53	39	64	23	73.5	50	120	12
PL32	125	25.5	152	49	M6	197	187	80	91	42	62	48	84	25	88	64	160	12
PL50	175	33	200	62	M6	276	266	120	117	63	75	57	110	29	118.5	90	240	16

OSP-E Belt – If combined with a linear guide, please also state position of linear guide

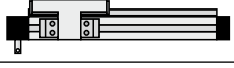
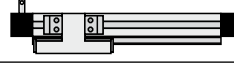
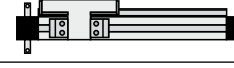
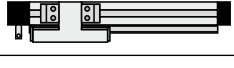
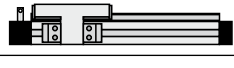
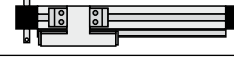
Position of Drive Shaft Standard = 0	Position of Drive Shaft Opposite to Standard = 1	Position of Drive Shaft Both Sides = 2
Position of Guide Standard Guide opposite the drive shaft 	Position of Guide Standard Guide opposite the drive shaft 	Position of Guide Standard Guide opposite the drive shaft 
Opposite to Standard Guide on same side as drive shaft 	Opposite to Standard Guide on same side as drive shaft 	Opposite to Standard Guide on same side as drive shaft 

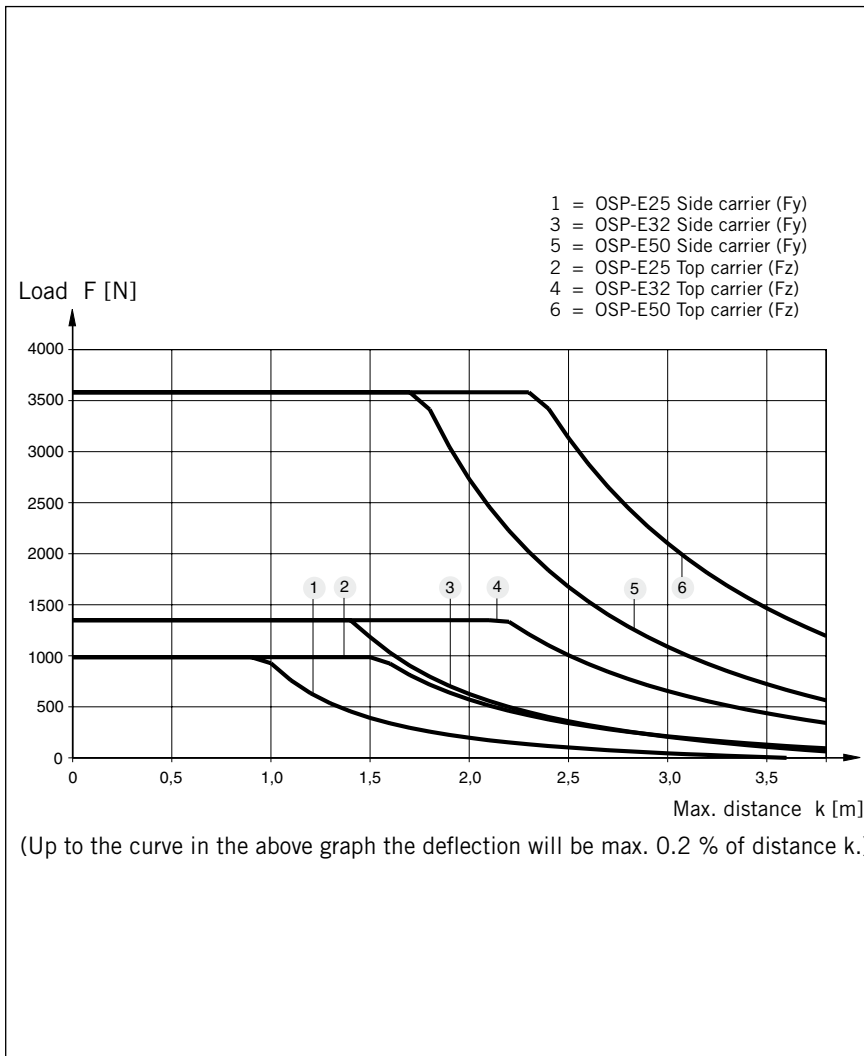

Guide Mounting

(see page 149)

Guide mountings are required from a certain stroke length to prevent excessive deflection and vibration of the actuator. The diagrams show the maximum permissible unsupported length in relation to loading.

