

DATASHEET

ITEM: 39386

WHEELSU 175X50/60 BB FIXED M22

WHEEL SERIE

Monolithic aluminium wheels, suitable for high temp applications; available with ball bearings.

Wheel fitted with ball bearings.

FORK DESCRIPTION

M22 series, Medium-light pressed steel fork assemblies, zincplated.

TECHNICAL DETAILS

Wheel diameter	(D)	175 mm
Tyre width	(E)	50 mm
Tyre width	(E)	20 mm
Reference weight		0,995 kg
Overall height	(H)	203,5 mm
Top plate outer dimensions	(AxB)	135x110 mm
Bolt hole spacing	(axb)	105x75 mm
Bolt hole spacing	(axb)	105x80 mm
Fixing bolt diameter	(g)	10 mm
Fork width	(U)	60 mm
Load capacity		300 kg

Possible options :

Wheel replacement	39036	CC
-------------------	-------	----

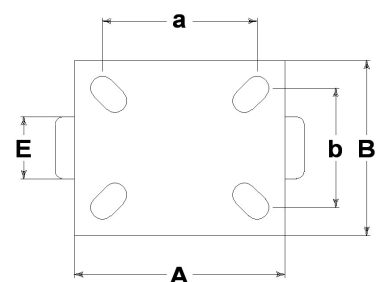
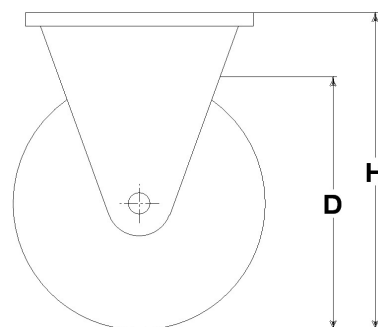

GENERAL INFORMATION / RECOMMENDATIONS AND WARNINGS

The cited text and the complete catalogue in their most up-dated versions are available in our web-site www.lagspa.eu/web/downloads. The dimensions, descriptions, specifications and illustrations herein are indicative and subject to variations without notice. The fact that products are illustrated herein does not necessarily imply they are available from stock nor does it place us under any obligation to supply them. Tests carried out refer to the original products with original accessories: the replacement of one of the components with others of different manufacture might prevent the same results from being achieved and will automatically invalidate any guarantee. Please contact our technical service concerning any special application.