

# SERIPLEX® Intelligent Wiring System

Class 8330



## CONTENTS

Description .....	Page
<b>System Overview</b>	
Technical Overview .....	3 - 4
Basic Operation .....	5 - 6
SERIPLEX Component Network Topologies .....	7
Additional Information .....	8
<b>Product Information</b>	
Host Interfaces .....	9 - 11
I/O Modules and Embedded Products .....	12 - 47
Cabling Components .....	39 - 44
Software, Set-up Tool and Accessories .....	48 - 52
Appendix A: Host Interfaces .....	53
Appendix B: Selection Guide .....	54 - 55



Schneider Electric Brands



**SQUARE D**  
Schneider Electric

# SERIPLEX® Intelligent Wiring System

## Table of Contents

### SYSTEM OVERVIEW

Description . . . . .	Page
<b>Technical Overview</b>	
Simplicity Makes Sense . . . . .	3
The Choice Depends on the Job . . . . .	3
Simple Design Means Lower Costs . . . . .	3
Fast, Efficient, Flexible and Robust . . . . .	3
Data Integrity and System Reliability . . . . .	4
Error Detection Features . . . . .	4
Redundancy Capabilities . . . . .	4
<b>Basic Operation</b>	
Simple Elegance . . . . .	5
Why Use the SERIPLEX Control Bus . . . . .	5
Support You Can Count On . . . . .	6
Set-Up Tool . . . . .	6
Power Supplies . . . . .	6
SERIPLEX Component Network Topologies . . . . .	7
<b>Additional Information</b>	
Higher Level Networks . . . . .	8

### PRODUCT INFORMATION

Description . . . . .	Page
<b>Host Interfaces</b>	
Interface for TSX Momentum Controllers . . . . .	9 - 10
CPU Interface Cards . . . . .	11
<b>I/O Modules and Embedded Products</b>	
Discrete I/O Modules . . . . .	12-14
General Purpose Relay . . . . .	15
Medium Density Discrete I/O Modules . . . . .	17-18
Four Channel Analog Input Modules . . . . .	19-20
Four Channel Analog Output Modules . . . . .	21-22
High Density Discrete I/O Boards . . . . .	23-24
High Density Analog I/O Boards . . . . .	25-26
Dedicated 30MM Push Button Modules . . . . .	27-30
Material Pull Pendant Station . . . . .	31-32
XUJ Photoelectric Communication Modules . . . . .	33-34
IEC Contactor Adaptor Module . . . . .	35
NEMA Style Contactor Adaptor Module . . . . .	36-37
<b>Cabling Components</b>	
Building a Catalog Part Number . . . . .	38
Standard Cable (Stock & Non-stock) . . . . .	39
Quick-change Mini-Style Connectors . . . . .	40
Quick-change Micro-Style Connector Standard & Adaptor Cable Assemblies . . . . .	41
Quick-change Micro-Style Connector Cable Splitters . . . . .	42
Quick-change Mini-Style T's and Receptacles . . . . .	42-44
TJUNCT Module . . . . .	45
Dedicated Module Panel Cabling Products . . . . .	46
Ferrules and Related Tools . . . . .	47
<b>Accessories</b>	
Set-up Tool . . . . .	48
Toolbox Software . . . . .	49
Conditioning Modules . . . . .	50-52
Appendix A: Host Interfaces . . . . .	53
Appendix B: Selection Guide . . . . .	54-55

For technical support call 1-919-217-6509 or to fax inquiries 1-919-217-6508.

For a more up-to-date listing of catalog and technical documentation available, call the Square D D-Fax™ fax on demand system at: 1-800-557-4556. For all additional information contact your Local Field Sales Office.

*NOTE: Square D and Telemecanique Products*

# SERIPLEX® Intelligent Wiring System

## Technical Overview

### Simplicity Makes Sense

Sometimes, a simple idea can have the greatest impact. The wheel, the lever, the inclined plane—all simple technologies that have come to symbolize progress. The SERIPLEX component network, too, represents a leap forward in technology. The SERIPLEX network gives you superior engineering, proven reliability and extensive product support. But best of all, it brings simplicity to your network applications.

### The Choice Depends On the Job

If your specifying a component network, then your faced with lots of choices. But making the right choice doesn't have to be complicated. Only a few networks can significantly reduce control system costs by replacing bundles of individual wires with a single low-voltage cable. This "installed cost" is important to consider.

Installing an intelligent I/O networking system means you spend less time and use less material to build and maintain your control system. Once you've analyzed the benefits of using a component network over a traditional hard-wired system, then consider the nature of your application to decide which type of network is best and most cost-effective. The fieldbus industry already recognizes three distinct levels of networks:

Ether-Net TCP/IP — high functionality communications generally used to link computers and to control complex factory floor devices.

Byte-level Networks — ideal for moderate-size data packets involving extensive messaging. HMI Control, downloading of application programs and servo drive operating parameters.

Bit-level Networks — provide the fastest through-put with deterministic performance. Less expensive than byte-networks, they're the best choice for common components such as photosensors, push-buttons, contactors and simple analog signals, which account for more than 80 percent of the devices in a typical factory floor control application.

Bit-level networks also provide greater I/O capacity and longer cable runs without topology restrictions. They provide unmatched flexibility and are easier to install and maintain. No other network is as simple to install and use.

Since its introduction in 1990, the SERIPLEX network has grown to have the largest installed base of any component network, with 1.5 million I/O points in 2,000 different installations. Every day in North America, Europe, Asia and Australia, SERIPLEX networks simplify a wide variety of applications including industrial control, building/facility automation, data acquisition and even amusement parks.

Square D Company supports the SERIPLEX network because it is a proven component network with flexibility in mind. From its inception it has been designed to effectively and efficiently network the basic bit-level devices on your plant floor. Unlike most networks that require a large investment in software and training, SERIPLEX network technology is simple and easy to use.

### Simple Design Means Lower Costs

Because the SERIPLEX ASIC "chip" is very small and inexpensive, it can be directly embedded in small control and sensing devices such as push-buttons and relays. Most networks require either interposing I/O modules or large and expensive network connections. The SERIPLEX network creates I/O connections at the point of use, which leads to an overall decrease in the cost per node.

Application designers can easily implement diagnostic functions because the SERIPLEX network is designed to be simple. This simple design practically eliminates the communications overhead associated with message addressing, characterizing and verification, so most common network problems can be diagnosed and fixed by electricians.

By eliminating the need for excess wiring, the SERIPLEX network can dramatically lower the cost of installation and maintenance, and reduce downtime. This simple design also makes it easy to reconfigure a network, replace devices or change their locations anywhere in the network. Projects that used to take system integrators days can now be completed by electricians in only a few hours.

Because the SERIPLEX component network lacks complex application layers, interoperability is not a problem. The simplicity of the SERIPLEX network makes implementation a snap for both vendors and application engineers. It would be difficult for a manufacturer to design a SERIPLEX device that wasn't interoperable. It's a truly open standard that accommodates virtually any device. You won't ever waste time matching the elements of your control system.

### Fast, Efficient, Flexible and Robust

Most networks are only efficient for data lengths of 16 bits or more, which makes them impractical and costly for simple control devices. In contrast, the SERIPLEX network protocol is highly efficient for data ranging from 1 to 64 bits in length. Response time is less than a millisecond for 128 I/O points. Most other networks, laden with message-oriented and overhead-intensive protocols, respond much slower, even though their baud rates are higher.

With a SERIPLEX network, data efficiency can reach 98 percent, which means that 98 percent of the time on the network is used to transmit actual data bits. Typical data efficiency in other networks is around 50 percent. Maximum data efficiency of a CAN-based system is less than 60 percent.

The SERIPLEX network cable can be configured in virtually any topology, with a total cable run of up to 5,000 feet. Most other networks are limited to a single cable configuration with runs of only about 1,000 feet. And since programming and set-up takes mere seconds, the SERIPLEX network has an extremely low installed cost. The flexibility translates to additional cost savings after installation.

The SERIPLEX network can support more than 7,000 I/O points connected through more than 3000 physical network nodes.



# SERIPLEX® Intelligent Wiring System

## Technical Overview

### Data Integrity & System Reliability

Extensive error-detection features have been built into the SERIPLEX control bus.

- Bus integrity is checked by the CPU interface card at the end of every scan period. These integrity checks include detection of:
  - loss of clock signal
  - data line shorted to bus power or common
  - over- and undercurrent conditions
  - excess data line capacitanceDepending on the nature of the fault and the application software, bus operation may either be halted or placed into an “emergency mode” of operation.
- Bus integrity is checked by every device on the bus at the end of every scan period. This is accomplished by means of a ‘bus fault detect pulse’ transmitted by the clock source during every end-of-scan sync period. Presence of this pulse indicates proper data line operation, proper clock operation, and proper voltage levels. If this pulse is not properly detected, the last output data values are discarded and devices revert to their default output states.
- The optional Data Echo feature allows a host to verify that a single-bit signal has been properly received by a remote device. This feature simply echoes a bus output signal back onto the bus as an input signal. The host’s receipt of this echoed data directly indicates that:
  - the data value was received correctly
  - the receiving device is properly communicating with the bus
- The optional CDR (Complementary Data Retransmission) feature provides verification that a multi-bit signal (for instance, an analog value) has been correctly received. This feature may be enabled for individual 8- or 16-bit input or output signals.
- SERIPLEX device vendors may include device diagnostics if they choose, and the SERIPLEX chip makes it easy to provide diagnostic bits in addition to data bits. SERIPLEX specifications place no restrictions or requirements on the type or quantity of diagnostic data which can be reported by any device.

*NOTE: Data Echo, CDR, and device diagnostic features are optional, so that the SERIPLEX bus does not need to waste time transmitting unnecessary “overhead” data. Users can tailor a system both to provide reliable verification of critical data signals and to update all signals quickly and deterministically.*

### Error Detection Features

With most control networks, the common response to detected errors is to re-transmit data. This, in turn, affects the response time and determinism of the network. The retransmission consumes time which should have been allocated for the transmission of new data. It is possible for a network subjected to noise to attempt retransmission of data to the extent of “starving” its application of necessary control data!

It is important to note that the error-detection and correction features used by other networks are precisely that -- error-detection and correction. While such features prevent action from being taken on invalid data transmissions, they do not prevent these invalid transmissions from occurring.

By contrast, the SERIPLEX control bus is specifically designed to prevent noise from interfering with the transmission of data in the first place, allowing it to maintain its fast and deterministic performance *even in the presence of severe disturbances*.

Specific features which contribute to preventing noise interference are:

- A wide data line signal swing of 12V peak-to-peak, with switching levels of 7.5 Vdc high and 3.0 Vdc low. These switching levels create very desirable, broad switching hysteresis. Combined with a relatively powerful 30 mA data-line driver, these features effectively “swamp out” most noise or signal reflections.
- The clock line is driven both high and low at even greater current levels than the data line, with the same hysteresis levels, making it even less susceptible to electrical noise and signal reflections.
- The relatively low transmission frequency made possible by the low-overhead protocol, allows the use of low-pass filters within every device, effectively filtering out most high-frequency noise disturbances.
- The synchronous nature of the SERIPLEX bus means that noise pulses must coincide precisely with the falling edge of the clock signal in order to disturb operation of the bus, greatly reducing the statistical probability that spurious (that is, asynchronous) noise will disrupt data transmission.
- Shielded transmission cables reduce noise susceptibility, as well as limit RF emissions.
- The optional Digital Debounce feature allows an application designer to require signal stabilization before changing logic states. This will extend the response time by a factor of 2 or 3 frame scans, depending on the level of sampling chosen by the application designer

### Redundancy Capabilities

The SERIPLEX control bus provides greater redundancy capability than any other low-level control network available. Specific SERIPLEX control bus redundancy support features include:

- Support for loop wiring configurations. — This provides inherent connection redundancy in the event of a single break in the transmission cable.
- The use of truly redundant network cables. — SERIPLEX’s free topology allows this, subject to the limits of overall network cable length.
- Support for redundant I/O devices. — The inherent “wire-OR” capability allows multiple devices with identical functions to share the same signal address.
- Support for multiple network power supplies.



# SERIPLEX® Intelligent Wiring System System Overview

## BASIC OPERATION

SERIPLEX Control Bus is a simple method of connecting control system input and output devices using a single cable that reduces installed cost by 30 - 70%. Introduced in 1990 after years of development and refinement, the SERIPLEX control bus received instant recognition in the market place, including Control Engineering's Editor's Choice Award for Distributed Control and the Excellence in Design Award.

The SERIPLEX control bus has over three million I/O points installed at over 3,000 installations. Existing users are involved in a broad range of industries including automotive manufacturing and assembly, entertainment, semiconductor fabrication, material handling and paper processing.

As an open-architecture technology, this low-level control network is supported by dozens of companies who manufacture products which either contain the SERIPLEX chip, or support SERIPLEX installations through software, PC and PLC interfaces, cable, connectors and other related products. The SERIPLEX control bus has earned its reputation for simple elegance.

## Simple Elegance

The SERIPLEX control bus is as easy to understand as it is to apply. Further detail is provided in this and other documents for the SERIPLEX control bus. In its simplest form, here is a quick overview of the very basic operation:

- Each component on the SERIPLEX control bus is given an address:
  - The address is a 3-digit identifier between 001 and 255.
  - The address is held in the SERIPLEX chip, which is embedded in each of the control components or I/O modules.
  - Addresses are assigned to each component or I/O module via a hand-held Set-up Tool.
- Each of the control components are parallel connected by a 5-conductor cable. The function of the conductors is:
  - V+ power
  - bus common
  - clock line
  - data line
  - shield drain
- A constant clock pulse is generated on the clock line.
  - Each SERIPLEX chip counts the clock pulses.
  - When the number of clock pulses counted is equal to the SERIPLEX chip address, a discrete signal (on or off) is exchanged between the control component and the data line.
- After counting through the 255 addresses, a synchronization pulse is sent out on the clock line, and the process begins again.
  - Note that it is possible to scale the control bus for less than 255 addresses for faster response times.
- The SERIPLEX control bus can be operated with a host controller (master/slave) or without a host controller (peer-to-peer).

When putting together a SERIPLEX control bus installation, the basic components needed are:

- I/O modules or control components containing the SERIPLEX chip
- a Set-Up Tool
- cable and connectors
- a power supply for the control bus
- a clock source (a clock module for peer-to-peer operation, a CPU interface card for master/slave operation)
- optional: a host controller (PC or PLC) with related software – needed for master/slave operation only

## Why use the SERIPLEX Control Bus

- Distance – 5,000+ foot cable runs allowed
- Simplicity – easy to understand, quick to install
- Speed – 0.20 msec. update for 32 addresses
- Determinism – data timing is exact and repeatable
- Economy – 30% to 70% installed cost savings
- Interoperability – the protocol is transparent to the user
- Capacity – accommodates over 255 inputs and 255 outputs
- Versatility – handles both digital and analog inputs and outputs
- Convenience – works with standard off the shelf control components
- Compatibility – can operate with over a dozen different software packages
- Flexibility – can be used with either a PC or a PLC or as a stand alone system
- Proven reliability – over 3,000,000 installed I/O points in industrial applications
- Open architecture – many manufacturers already incorporating in their components
- Modifiable – add, change or remove components easily without system reconfiguration
- Free topology – use any wiring configuration (star, loop, tree, trunk with drops, daisy chain)

A new level of elegance in industrial control, providing the most cost-effective low level control network solution available today!



# SERIPLEX® Intelligent Wiring System System Overview

One of the most robust data transmission methods available today, the SERIPLEX network is inherently immune to noise. Its ASIC chip also provides Digital Debounce and Data Echo features to allow even greater noise filtering while providing reliable data verification. CDR (complimentary data retransmission), a CRC16 equivalent error checking method, is also available for extensive data reliability.

## Support You Can Count On

The SERIPLEX network is a truly open architecture that has encouraged the development of related products. In fact, more than 40 hardware and software vendors have designed products that provide interconnectivity to the SERIPLEX network cable, which allows direct integration of valves, sensors and actuators as well as PC, PLC and MMI control.

Square D Company is dedicated to developing and supporting technology that best meets your needs. Square D introduced some 60 new SERIPLEX products in 1997 alone, including a variety of discrete modules, CPU interface cards and accessories, cable connectors and power supplies.

Square D supports the SERIPLEX Control Bus because of its superior bit-level control solution. With that our customers also get reliable Square D engineering and product support, as well as availability from the largest network of distributors in the industry.

## Power supplies

The following table of products is provided as a convenience to the user. **None of the following power supplies are carried by the Square D Company.** Common characteristics:

- Single output models
- Provided with solder lugs
- Regulated, linear supplies
- Short circuit and overload protection

Manufacturer	Manufacturer Part #	Output Rating	Approximate Dimensions	Alternate Source	Alternate Source Stock Number
Power - One	HB24-1.2-A	24V@1.2A*	4.87" x 4.00" x 2.10"		
Power - One	HC24-2.4-A	24V@2.4A*	5.62" x 4.87" x 2.95"		
Power - One	HB28-1-A	28V@1A*	4.87" x 4.00" x 2.10"		
Power - One	HC28-2-A	28V@2A*	5.62" x 4.87" x 2.95"		
SOLA — A Unit of General Signal	SLS-24-012	24V@1.2A	1.62" x 4.83" x 3.99"	Newark Electronics	89F1262
SOLA — A Unit of General Signal	SLS-24-024	24V@2.4A	2.50" x 5.62" x 4.87"	Newark Electronics	89F1263
Schneider Electric	TSXSUPA02	30V@2.4A	5.97 x 2.89 x 4.73		

## Power Supplies (reference NEC 725)



The use of a regulated, linear power supply is strongly recommended for all SERIPLEX control bus applications. The DC output of all supplies must be isolated from the AC side of the power supply and the power supply case. Use a power supply that has its own current limit protection.

Power budgeting and power balancing determines the size, quantity and placement of the control bus power supplies. This is required, in particular, for large or long installations. Obtain a copy of the "SERIPLEX Design, Installation and Troubleshooting Guide" (bulletin #30298-035-01) for full details relating to power budgeting and power balancing.

The SERIPLEX control bus is designed as a Class 2 Remote Control, Signaling and Power-limited Circuit and is governed by the limitations outlined in National Electric Code (NEC) Article 725. Be sure all power supplies selected follow the constraints outlined in NEC and any other pertinent local codes. The key limitation is 100 VA power source maximum nameplate rating. In most cases, this will limit a power supply to 4 amps maximum. Additional details are provided in NEC Article 725.

If for some reason an application should require a switching power supply instead of a linear power supply, obtain a copy of document #8320AB9601 "Using a Switching Power Supply with a SERIPLEX Control Bus."

## Set-Up Tool

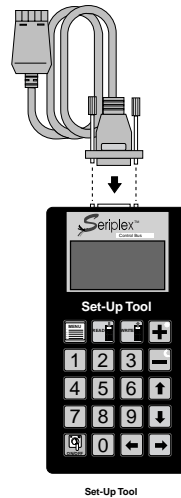

The SERIPLEX Set-Up Tool is a portable device used to enter data into an I/O device containing a SERIPLEX ASIC. Typically, this data consists of 2 signal addresses and the bus operating mode (master/slave or peer-to-peer). Other options, used primarily for peer-to-peer operation, may also be selected.

Once data is entered, it can be loaded into the EEPROM memory within the ASIC, so that it is retained even while power is removed from the I/O device. The Set-up Tool can also read set-up data from the ASIC, so that this data can be verified, changed, or loaded into another device.

I/O devices are disconnected from the SERIPLEX bus to be connected to the Set-up Tool through a short set-up cable. Once valid signal addresses are loaded into an I/O device, it becomes capable of communicating properly through the bus.

"resting" state, the Data line is pulled high by the source of the Clock signal (either a clock module or host controller).



# SERIPLEX® Component Network Topologies

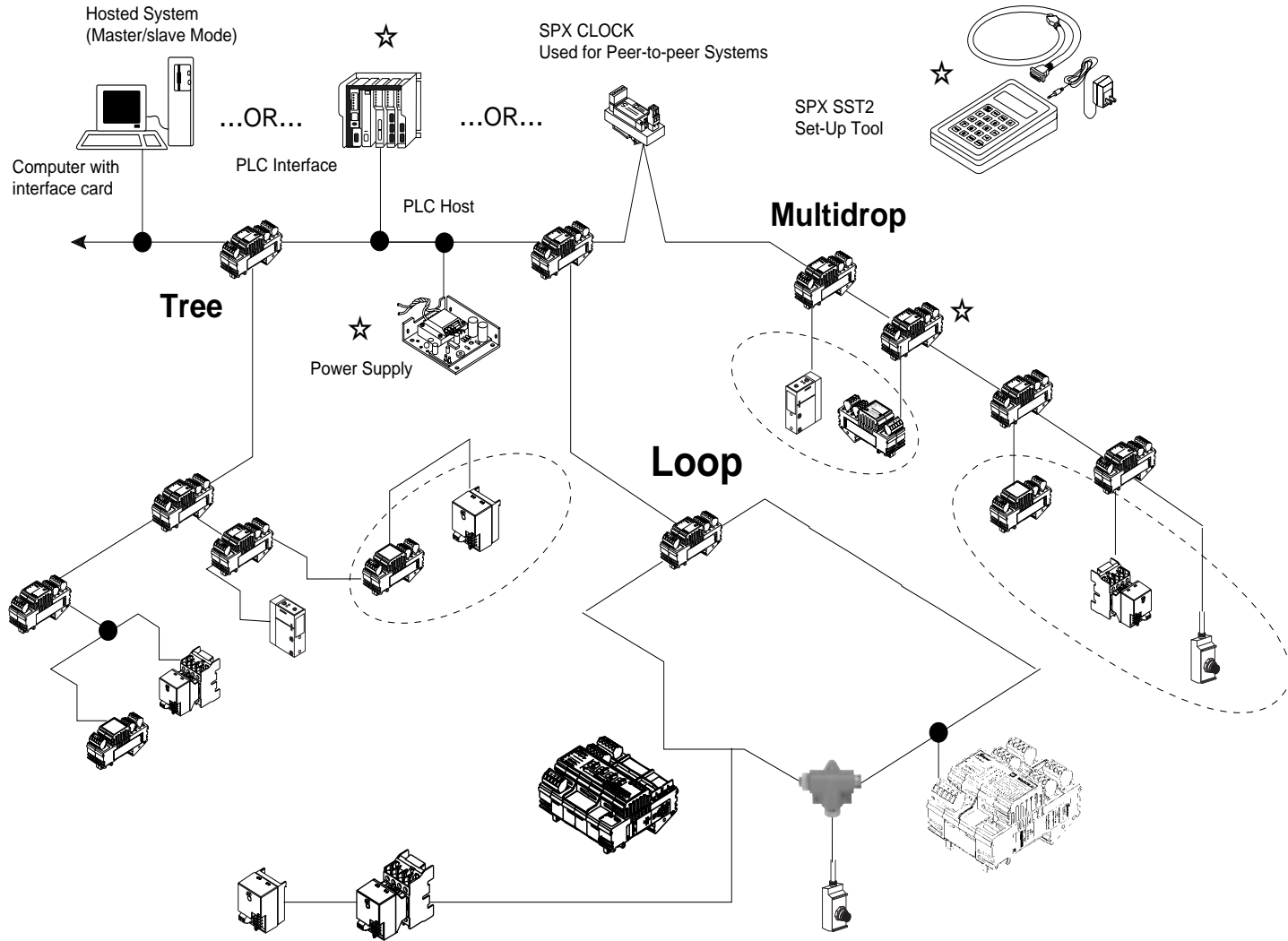

☆ Mandatory for the system.  
 NOTE: In all topologies, the device connection to the bus is parallel.

# SERIPLEX® Intelligent Wiring System System Overview

## Higher-Level Networks

Unlike most other control networks, the SERIPLEX control bus is designed to be efficient and cost-effective when used to connect very simple control devices. While it is capable of transmitting blocks of up to 30 bytes of data, it is typically used for devices which transmit from 1 to 8 digital or 12 bit analog signals. While higher-level control networks such as Ethernet and Modbus Plus are better-suited to transmitting large quantities of data, they are relatively large and expensive to use in simple control devices such as push-button, sensors, contactors, and valves.

The graph shows the control devices for which several open control networks can be used cost-effectively. As the graph implies, the SERIPLEX control bus can be used to achieve very significant cost savings in the installation of the simple control devices most frequently used within control systems.

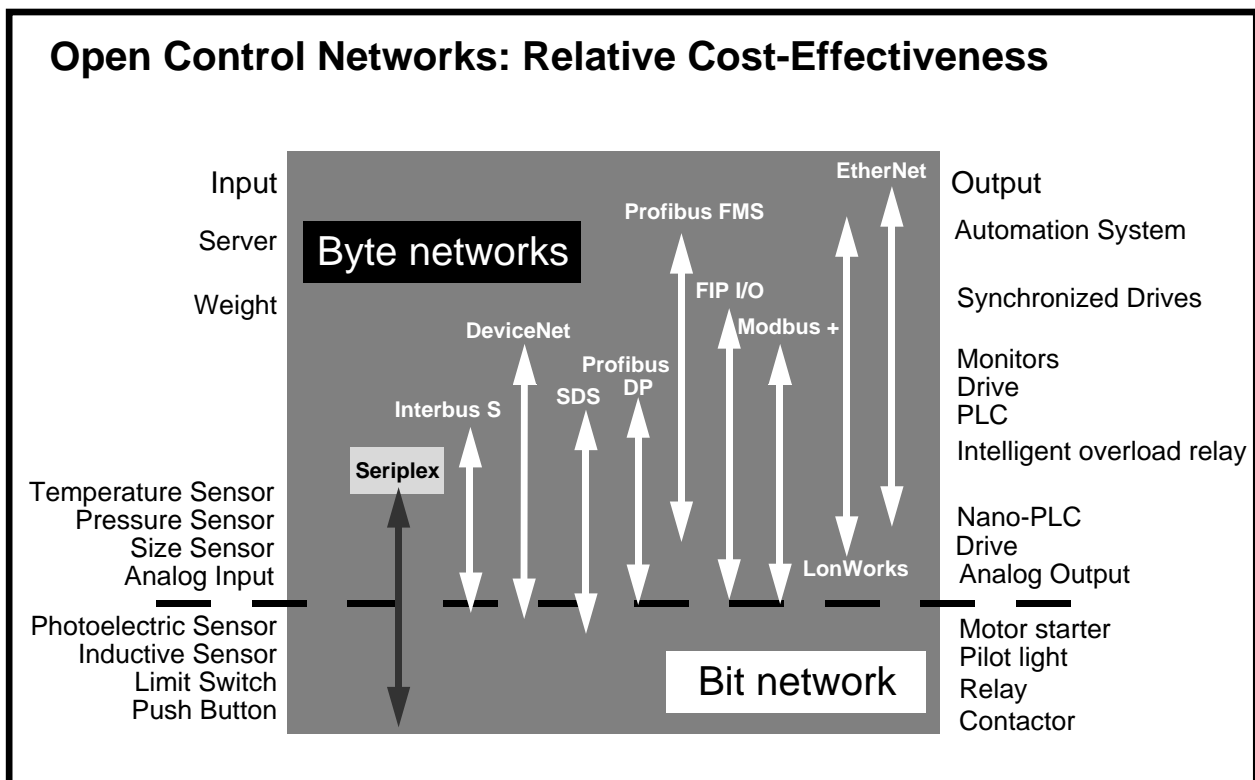

# SERIPLEX® Intelligent Wiring System

## Product Information — Host Interfaces

### INTERFACE FOR TSX MOMENTUM CONTROLLERS

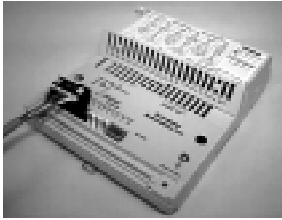

This SERIPLEX Interface (170 ANM 050 10) allows a TSX Momentum processor adapter or communications adapter to exchange I/O data with a SERIPLEX bus. The interface acts as a slave to its host controller, and as a master for the SERIPLEX bus.

The interface takes the form of a Momentum I/O base unit, on which a Momentum processor adapter or communications adapter is mounted. This provides three powerful control architectures:

- Stand-alone Momentum controllers, with SERIPLEX I/O devices
- Networked, distributed Momentum controllers, some or all of which may connect to SERIPLEX I/O devices
- A centralized control processor, connecting to SERIPLEX bus devices and/or other types of I/O devices through a higher-level control network, such as Modbus Plus, DeviceNet, Ethernet, Interbus-S, or Profibus DP.

### Product Features

- SERIPLEX bus data appears to host as 32 input registers and 32 output registers, with control and status functions contained in first register.
- Extensive fault indication both to user through front-panel LEDs, and to host through status register.
- Capacity of 992 discrete I/O, 62 analog I/O, or combinations.
- SERIPLEX bus operation controlled by host's application program.
- Programming function blocks provided for use in both Modsoft and Concept PLC programming software.
- Windows-hosted Calculator program determines control register value and register data map, based on interface parameter selections.
- Supports SERIPLEX Version 2 data error detection methods - Digital Debounce and CDR (Complementary Data Retransmission).
- DIN rail or panel mounting.
- Operates from 24 Vdc SERIPLEX bus power.

### Product Selection Information

Catalog Number	Description
170 ANM 050 10	SERIPLEX Interface for TSX Momentum Controllers

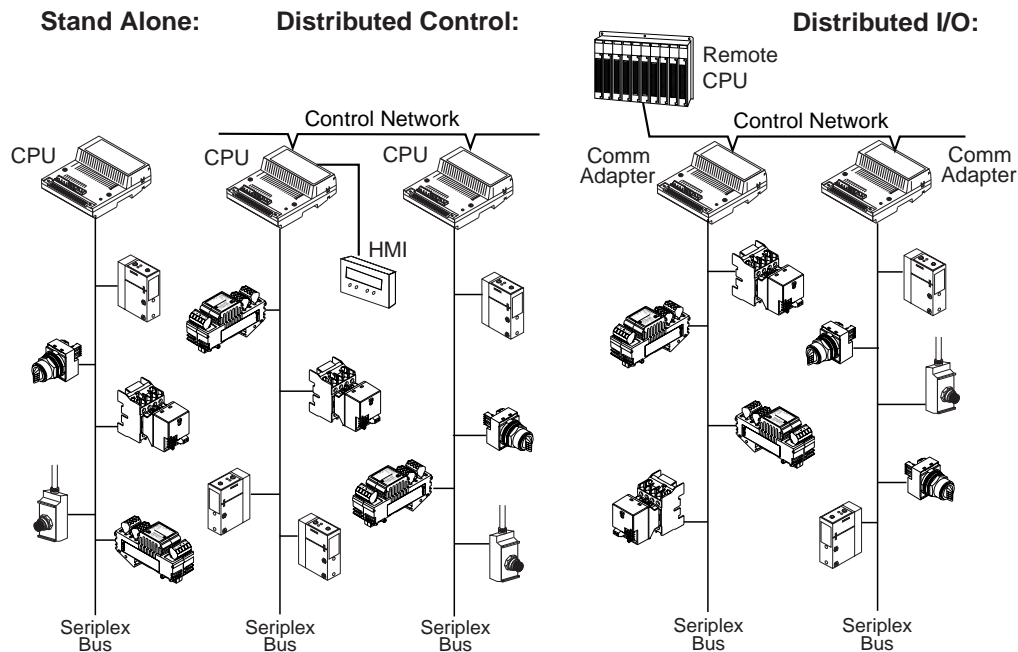

# SERIPLEX® Intelligent Wiring System

## Product Information — Host Interfaces

### Specifications — Momentum SERIPLEX Interface

#### Physical Characteristics

Parameter	Value
SERIPLEX bus connection ▲	<ul style="list-style-type: none"> <li>One five-pin header: 0.200 inch centers with mating screw terminal connector, Phoenix SMSTB 2,5/5-ST-5,08 or Square D SPX TERMBUS</li> <li>One five-pin header: 0.156 inch centers with mating insulation-displacement connector, AMP 641229-5</li> </ul>
Power connection ●	2-pin, removable screw terminal connector Phoenix SMSTB 2,5/2-ST-5,08
Operating temperature	0 to 60 °C (32 to 140°F)
Storage temperature	-25 to 80 °C (-13 to 176°F)
Relative humidity	5 to 95%, non-condensing

- ▲ Both connectors are wired in parallel.
- The power connection is wired in parallel to the bus connections

#### Electrical Characteristics

Parameter	Value
Nominal power voltage	24 Vdc
Power voltage range	19.2 to 30 Vdc
Current draw	450 mA maximum, at 24 Vdc
Power supply hold-up time	1ms
Electrostatic Discharge (ESD) (IEC 61000-4-2, level 3)	8 kV air, 6 kV contact
Radiated RF (IEC 61000-4-3, level 3)	10 V/m, 80 MHz to 1 GHz
Electronic Fast Transient Burst (EFTB) (IEC 61000-4-4, level 3)	1000 V – SERIPLEX cabling 2000 V – power lines
Surge (IEC 61000-4-5, level 2)	500 V @ 2 Ω, power to common 1 kV @ 12 Ω, power/common to shield 2 kV @ 2 Ω, shield to shield (at a distance of 500 ft.)
Approvals:	UL File Number E114926 CSA File Number LR53531 FM (CL-1, DIV2, GRP A, B, C, D) 3004337 CE

#### SERIPLEX Bus Parameters

Parameter	Value	
Data capacity	Non-multiplexed	240 input + 240 output bits (480 total) 15 16-bit analog input + 15 analog output signals
	Multiplexed	496 input + 496 output bits (992 total) 31 16-bit analog input + 31 analog output signals
Clock rate	10, 16, 25, 32, 64, 100, 147, or 192 kHz	
Frame length	64, 128, 192, or 256 addresses	
Bus operating modes	Master/slave only	
Address Multiplexing	Selection	50%, 75%, or 100% of available addresses
	Number of channels	4 or 8 channels
Digital input signal debouncing	Selection	Enable or disable for all non-multiplexed input signals
	Debounce length	3 data samples
CDR multi-bit data validation	Selection	All applicable data, all multiplexed data, or all multiplexed data plus half of non-multiplexed data
	Response time	Immediate or 3-frame ride-through
	Response method	Bus halt, or indication only
Fault response	Halt or Auto Restart	

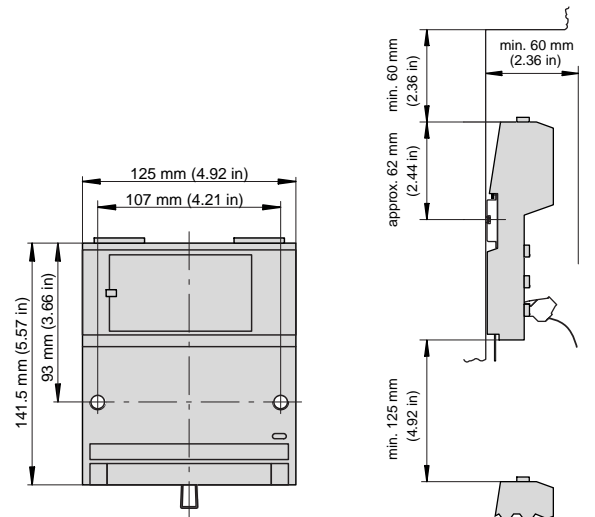

Mounting Hole Locations

Physical Dimensions

Catalog Number: 170 ANM 050 10



# SERIPLEX® Intelligent Wiring System

## Product Information — Host Interfaces

### CPU INTERFACE CARDS

The SERIPLEX CPU Interface Cards allow software running on a host computer to control and monitor sensors and actuators through a SERIPLEX control bus. These cards act as masters for a SERIPLEX bus, monitoring for bus fault conditions as well as exchanging input and output signals with I/O devices. The cards interact with the computer through a 2-kbyte memory interface, so that detailed knowledge of SERIPLEX protocol is not required to program the card.

#### Key Features:

- PC (ISA), PC/104, and VME interface cards
- Capacity of 7680 discrete or 480 16-bit analog signals
- Full selection of SERIPLEX bus parameters
- Full SERIPLEX data error detection:
  - Digital Debounce for discrete input signals
  - Complementary Data Retransmission (CDR) for analog and multi-bit signals
- Front-visible status and fault indicator lamps
- Compatible with all SERIPLEX I/O devices
- Version 1.5 emulation mode for software compatibility with earlier interface product versions
- 2-kbyte dual-port RAM memory interface to host for fast response and simple software interface
- Includes program-development aids on CD-ROM:
  - C-language programming library
  - Windows NT low-level driver, with Control Panel configuration utility
  - Programmer's Guide manual
- Software drivers available from several leading control and MMI software vendors
- Advanced programming features:
  - Host watchdog monitor
  - Heartbeat indication
  - Hardware interrupts to support exception-driven processing
  - 32-character text indication of card and bus status
  - Product identity and firmware version available in memory
- Auto Restart and other configurable responses to bus faults
- Special card operating modes:
  - Monitor mode reports inputs but disables outputs
  - Emergency State mode presets all outputs to known states
  - Data Pass-Through lets inputs directly control outputs without host intervention

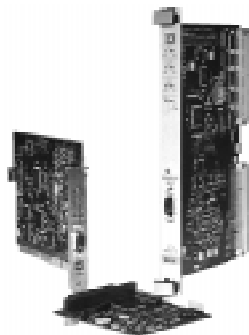

### Product Selection Information

Catalog Number	Description
SPX PCINTFV2	SERIPLEX PC Interface Card, ISA bus, half-slot AT
SPX PC104INTFV2	SERIPLEX PC/104 Interface Card
SPX VME6U1V2	SERIPLEX VME Interface Card, 6U
SPX INTFCBL0	SERIPLEX interface card cable, 4 ft., 9-pin D receptacle to bare wires
SPX RIBBONASM	SERIPLEX interface ribbon cable, 3 ft., 10-pin receptacle to 9-pin D plug

### Physical Characteristics

Parameter	Value	
Size	SPX PCINTFV2	Half-length PC-AT form factor (0.9 x 4.8 x 7.0 in.)
	SPX PC104INTFV2	PC/104 form factor (0.5 x 3.6 x 3.8 in.)
	SPX VME6U1V2	VME 6U form factor (0.8 x 7.4 x 10.3 in.)
SERIPLEX bus connection	SPX PCINTFV2	9-pin D-shell plug (DB-9P), SPX INTFCBL0 bus cable provided
	SPX PC104INTFV2	10-pin rectangular header, SPX INTFCBL0 bus cable and SPX RIBBONASM ribbon cable provided
	SPX VME6U1V2	9-pin D-shell plug (DB-9P), SPX INTFCBL0 bus cable provided
Operating temperature	0 to 60 °C (32 to 140 °F)	
Storage temperature	-25 to 80 °C (-13 to 176 °F)	
Relative humidity	5 to 95%, non-condensing	

### Electrical Characteristics

Parameter	Value	
Bus power	Nominal voltage	24 Vdc
	Voltage range	10.5 to 15 Vdc; 19.2 to 30 Vdc
	Current draw	300 mA max
Host power	SPX PCINTFV2	+5V: 450 mA typical, 725 mA max +12V: 2.5 mA typical, 55 mA max
	SPX PC104INTFV2	+5V: 425 mA typical, 650 mA max +12V: 2.5 mA typical, 55 mA max
	SPX VME6U1V2	+5V: 400 mA typical, 500 mA max +12V: 2.5 mA typical, 55 mA max
Approvals:	UL File Number E114926 CSA File Number LR53531 FM (CL-1, DIV2, GRP A, B, C, D) 2D5A9.AX	

### SERIPLEX Bus Parameters

Parameter	Value	
Data capacity	Non-multiplexed	255 input + 255 output bits (510 total), 15 16-bit analog input + 15 analog output signals
	Multiplexed	3840 input + 3840 output bits (7680 total), 240 16-bit analog input + 240 analog output signals
Clock rate	Version 1.5 emulation	16, 20, 25, 32, 50, 64, 75, or 100 kHz
	Version 2 (normal) operation	10, 16, 20, 25, 32, 50, 64, 75, 100, 125, 147, 167, or 192 kHz
Frame length	From 16 to 256 addresses, in multiples of 16	
Bus operating modes	Master/slave or peer-to-peer	
Address Multiplexing	Selection	Selectable by individual input or output words (16 consecutive bus addresses)
	Number of channels	2, 4, 8, or 16 channels with optional Priority Channel
Digital input signal debouncing	Selection	Selectable by individual non-multiplexed input signals
	Debounce length	2 or 3 data samples
CDR multi-bit data validation	Selection	Selectable by individual input or output words (16 consecutive bus addresses in one multiplex channel)
	Response time	Immediate or 3-frame ride-through
	Response method	Bus halt or indication only
Fault response	Halt or Auto Restart	



# SERIPLEX® Intelligent Wiring System

## Product Information — I/O Modules and Embedded Products

### DISCRETE I/O MODULES

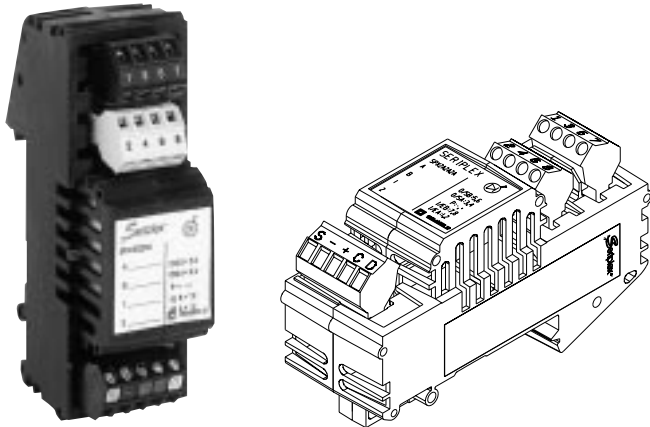

Universal discrete I/O modules provide an interface between the SERIPLEX control bus and most any I/O. Single-bit bus interface circuitry is used in these I/O modules. If multiplexed operation is used by the controller card, these I/O modules are scanned every frame. These I/O modules are not capable of being multiplexed.

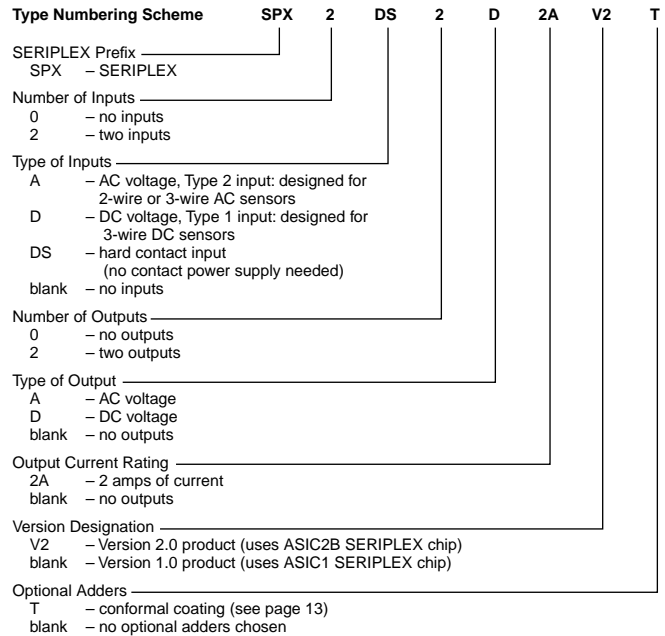

Catalog Number	Input Type (Qty of 2)	Output Type (Qty of 2)	Input Wiring Diagram	Output Wiring Diagram
SPX2A2A2AV2	Type 2 AC	2 amp AC	C	E
SPX02A2AV2	none	2 amp AC	—	E
SPX2A0V2	Type 2 AC	none	C	—
SPX2D2D2AV2	Type 1 DC	2 amp DC	B	D
SPX02D2AV2	none	2 amp DC	—	D
SPX2D0V2	Type 1 DC	none	B	—
SPX2DS2D2AV2	Hard contact	2 amp DC	A	D
SPX2DS0V2	Hard contact	none	A	—
SPX2D2A2AV2	Type 1 DC	2 amp AC	B	E

### Features

- LED indicators provide power-on status and input/output status.
- Pluggable connectors simplify installation and troubleshooting.
- Variety of inputs available:
  - AC Type 2 – Ideal for 2-wire or 3-wire AC sensor inputs
  - DC Type 1 – Best for 3-wire DC sensor inputs (sink or source)
  - Hard Contact – A hard contact closure drives the input. No external power supply is needed.
- Outputs rated 2 amps: AC and DC voltage outputs available
- Optional Logic C output selected by a jumper. Provides greater logic flexibility.
- All modules provide 2 inputs and/or 2 outputs

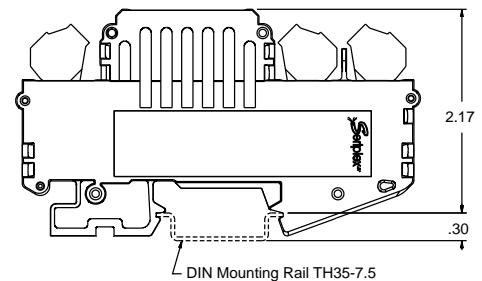
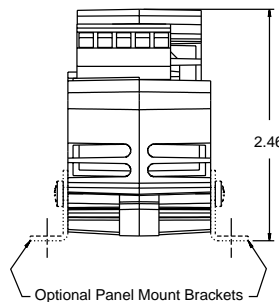
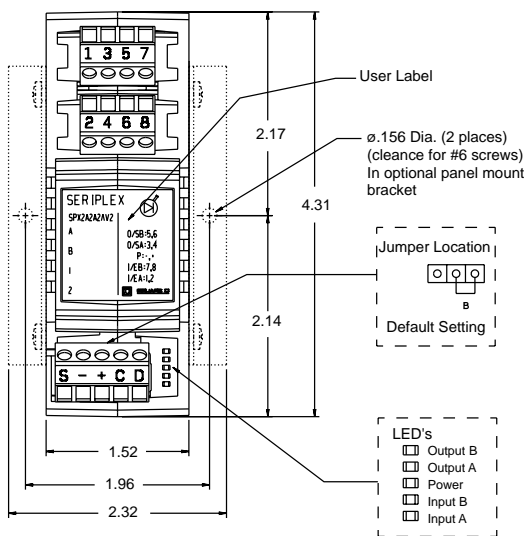

SPXSST2 Set-Up Tool ..... page 48  
 Cable ..... page 39  
 Ferrules and Other Cabling Accessories ..... page 47

CPU Interface ..... page 11  
 Power Supplies ..... page 6  
 System Overview ..... page 3 & 4

# SERIPLEX® Intelligent Wiring System

## Product Information — I/O Modules and Embedded Products

### Options, Replacement Parts and Accessories

Catalog Number	Description
SPXJUMPA	Spare jumpers. Quantity of 5 to a package.
SPXPANEL	Optional mounting legs for panel-mounting discrete I/O modules
SPXTERMBUS	Replacement terminal block – 5 terminals – bus connector markings
SPXTERM2468A	Replacement terminal block – 4 terminals – 2,4,6,8 connector marking – almond (white)
SPXTERM1357B	Replacement terminal block – 4 terminals – 1,3,5,7 connector marking – black
SPXTERM2468B	Replacement terminal block – 4 terminals – 2,4,6,8 connector marking – black
SPXUSER	Replacement user label (has marking surface for addresses and control words). Quantity 10.
Add a "T" to the end of a catalog number *	Conformal coating. Increases Micro-Environmental Category rating from MEC pollution degree II to MEC pollution degree III, as outlined in IEC 664-1, section 2.5.1. Conformal coating meets MIL-I-46058C.

\* To order conformal coating for catalog number SPX2D2D2AV2, change to SPX2D2A2AV2T.

### General Specifications

Operating temperature: at nominal bus & input voltage at max & input voltage	Input or Output Only -25 to +70 °C (-13 to +158 °F)	Input plus Output I/O Module 25 to +65 °C (-13 to +149 °F)
Addressing and I/O module set-up temperature	0 to +70 °C (+32 to +158 °F)	
Storage temperature	-40 to +85 °C (-40 to +185 °F)	
Relative humidity	5 to 95%, noncondensing	
Micro-environmental category	II (per IEC664-1, Section 2.5.1)	
Shock (IEC 68-2-27)	30 g, 3 axis, 11 ms duration, half sine pulse	
Vibration (IEC 68-2-6)	10 to 55 Hz, 1 mm peak-to-peak, 1/2 hour in 3 axis	
Noise immunity: Electrostatic Discharge (ESD) Radio Frequency Immunity (RFI) Fast transients Surge	IEC801-2 IEC801-3 IEC801-4 IEC801-5 (draft)	
Approvals	UL File Number E114926 CSA File Number LR53531 FM (CL1, DIV2, GRP A, B, C, D) 4B7A6.AX● IEC1131-2 (where applied to I/O)	
Screw terminal conductor capacity	Single conductor: 12 AWG - 28 AWG Two conductors: 16 AWG - 28 AWG	
Screw terminal torque	0.5 - 0.8 N•m (4.4 - 7.0 lb-in)	
Fracture torque◆	1.1 N•m (9.6 lb-in)	
Wire strip length	11 mm (0.43 in)	
Power/heat dissipation per module	5.5 W total (bus power, inputs & outputs conducting) 0.6 W bus power only (@ 30 Vdc)	

- ◆ The fracture torque leads to damage of the screw shaft, stripping of the thread or deformation of the screw slot
- FM temperature ratings: SPX2D2A2AV2 T4  
All other AC modules T5  
All other DC modules T4

### Input Specifications

	AC Isolated	DC Isolated	DC Non-isolated
Catalog Number	SPX2A2A2AV2 SPX2A0V2	SPX2D2D2AV2 SPX2D0V2 SPX2D2A2AV2	SPX2DS2D2AV2 SPX2DS0V2
Number of inputs	2	2	2
Input type	Type 2 (2 or 3-wire sensors)	Type 1 (3-wire sensors only)	Hard Contact (Type 1)
Nominal input voltage rating	120 Vac	24 Vdc	24 Vdc
Operating input voltage range	74 to 132 Vac (rms)	11 to 30 Vdc polarity insensitive	9 to 30 Vdc
Input frequency range	50/60 Hz	n/a	n/a
OFF-state input voltage	≤20 Vac (rms)	+5 Vdc ≥ V <sub>in</sub> ≥ -5 Vdc	≤5 Vdc
ON-state input voltage	≥74 Vac (rms)	-11 Vdc ≥ V <sub>in</sub> ≥ +11 Vdc	≥9 Vdc
Maximum input current @ rated voltage	30 mA @ 132 Vac	15 mA @ 30 Vdc	15 mA @ 30 Vdc
Max allowable OFF-state leakage current	4 mA	0.5 mA	0.5 mA
Available current from +V terminal (@ 25 °C) per module	n/a	n/a	45 mA
+V short circuit current @ 25 °C	n/a	n/a	90 mA

### Input Specifications

	AC Isolated	DC Isolated	DC Non-isolated
Catalog Number	SPX2A2A2AV2 SPX2A0V2	SPX2D2D2AV2 SPX2D0V2 SPX2D2A2AV2	SPX2DS2D2AV2 SPX2DS0V2
Current through hard contacts	n/a	n/a	3.4 mA @ 24 Vdc typical
Input circuit isolation:			
channel-to-channel	1,500 Vac (rms)	1,500 Vac (rms)	n/a
channel-to-bus	1,500 Vac (rms)	1,000 Vac	n/a
Nominal impedance	8 kΩ @ 60 Hz		6.9 kΩ
OFF-to-ON response time▲	10 msec - typical	1 msec (max)	1 msec (max)
ON-to-OFF response time▲	20 msec - typical	1 msec (max)	1 msec (max)

▲ Turn-on/turn-off time is the electrical turn-on/turn-off time of the I/O module. Due to the nature of the SERIPLEX control bus, there is a possible delay before the signal will register on the SERIPLEX data line. The response time is a function of clock speed and frame size. See the "SERIPLEX Control Bus Design, Installation and Troubleshooting Guide" (Bulletin No. 30298-035-01) to calculate your system response time.

### Output Specifications

	2 Amp AC	2 Amp DC
Catalog Number	SPX2A2A2AV2 SPX2D2A2AV2 SPX02A2AV2	SPX2D2D2AV2 SPX2DS2D2AV2 SPX02D2AV2
Number of outputs	2	2
Output type	Floating AC output circuit, can connect to either Hot or Neutral side of AC line	Floating unipolar output cir- cuit, sourcing or sinking
Nominal output voltage rating	120 Vac	12/24 Vdc
Operating output voltage range	19 to 132 Vac (rms)	5 to 30 Vdc
Operating frequency range	50/60 Hz	n/a
ON-state voltage drop (terminal voltage @ 25 °C)	3.5 Vac (10 to 50 mA) 2 Vac (50 mA to 2 A)	1.5 Vdc @ rated current
Switching control	Zero-crossing switching, turn-on and turn-off	
Output current (each output) @ 25 °C bus down	10 mA to 2.0 A continuous 1.0 A pilot duty 0.6 A tungsten	2.0 A DC continuous 1.0 A pilot duty 0.6 A tungsten
Output current (per module) @ 25 °C bus down	4.0 A continuous	4.0 A DC continuous
Output circuit derating	(see following section)	(see following section)
Inrush current	10 A peak (sinusoidal) for 2 cycles, 1 rep/sec	
OFF-state leakage current	2 mA	100 μA
Output circuit isolation channel-to-channel channel-to-bus	1,500 Vac (rms) 1,500 Vac (rms)	1,000 Vrms 1,000 Vrms
Turn-on response time▲	11 msec	1 msec
Turn-off response time▲	11 msec	1 msec @ resistive load

▲ Turn-on/turn-off time is the electrical turn-on/turn-off time of the I/O module. Due to the nature of the SERIPLEX control bus, there is a possible delay before the signal will register on the SERIPLEX data line. The response time is a function of clock speed and frame size. See the "SERIPLEX Control Bus Design, Installation and Troubleshooting Guide" (30298-035-01)



Mark Compliant Listings:

SPX2D2D2AV2  
SPX02D2AV2  
SPX2D0V2



# SERIPLEX® Intelligent Wiring System

## Product Information — I/O Modules and Embedded Products

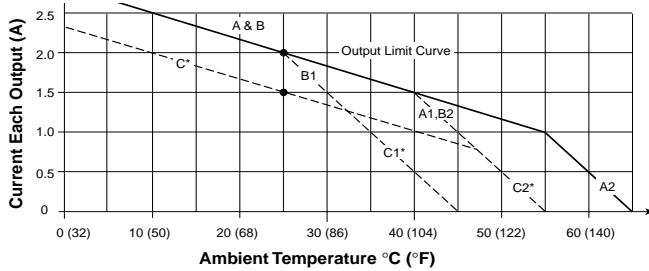

A = Bus down      B = Bus up      C = All other orientations  
 1 = 30 V bus      2 = 24 V nominal bus

### Temperature/Output/Module Orientation Derating Curves

The derating curve for modules stacked in a horizontal orientation (bus left or bus right, rather than bus up or bus down), must be shifted left 3 °C for every module located under it, plus 3 °C for every amp of output current in the modules under it.

### Bus Specifications

<b>SERIPLEX bus power requirements:</b>	
Nominal voltage rating	24 Vdc
Power supply voltage range	10.5 to 15 Vdc and 19.2 to 30 Vdc
Power supply current drain	15 mA typical, 20 mA maximum ▲
I/O module capacitance	75 pF
Bus clock frequency operating range	10 kHz to 200 kHz

▲ Add 4.2 mA for each input to an **SPX2DS2D2AV2** or **SPX2DS0V2** I/O module.

### LED Operation

The green LED indicator identifies that bus power is applied. Yellow LED indicators identify the input/output state of the SERIPLEX chip, and do not reflect the actual state of the physical inputs or outputs.

LED Designation	LED Color	Function and Corresponding Address	Related Terminal Numbers
O/S B	yellow	Output B	5, 6
O/S A	yellow	Output A	3, 4
P	green	Bus power	+, - (bus power)
I/E B	yellow	Input B	7, 8
I/E A	yellow	Input A	1, 2

### Wiring Diagrams

Use in conjunction with wiring diagrams provided with specific input and output devices.

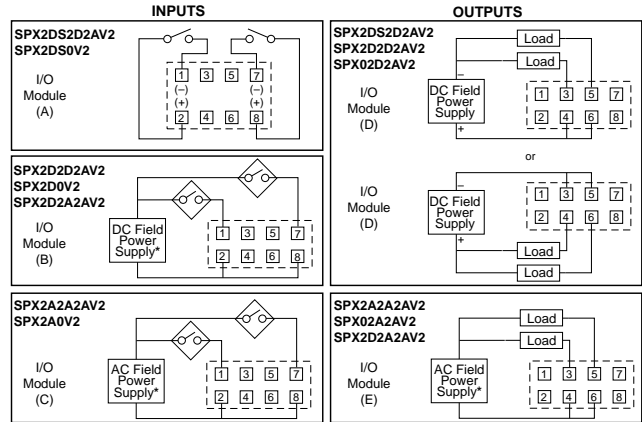

\* Polarity insensitive:  
 (+) and (-) are interchangeable.  
 L1 and L2 are interchangeable.

Product	Inputs	Outputs	Inputs	Outputs
<b>SPX2A2A2AV2</b>	C	E	B	X
<b>SPX02A2AV2</b>	X	E	A	D
<b>SPX2A0V2</b>	C	X	A	X
<b>SPX2D2D2AV2</b>	B	D	B	E
<b>SPX02D2AV2</b>	X	D		

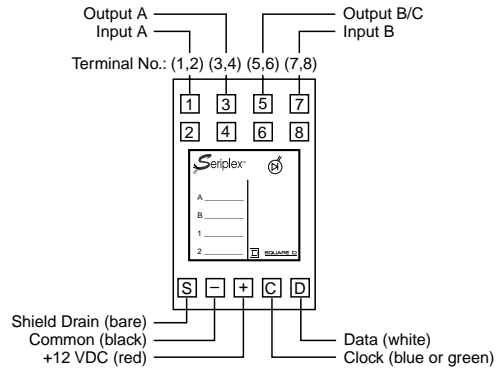

**GENERAL PURPOSE RELAYS**

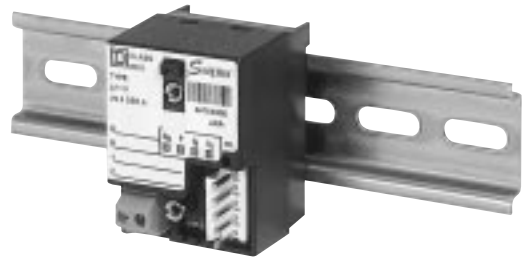
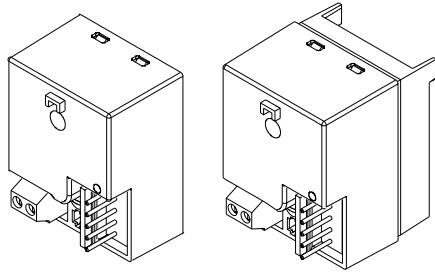

The **Class 8501 Type SPX11** general purpose relay provides an interface between the SERIPLEX control bus and a control output device. Single-bit bus interface circuitry is used in this module. If multiplexed operation is used by the CPU interface card, the general purpose relay is scanned every frame. This general purpose relay is not capable of being multiplexed.

**Features**

- Single pole single throw (SPST) electromechanical relay output
- Available input address for optional alarm signaling back to the host controller
- LED indicators provide power-on status and output status -- a convenient installation and troubleshooting aide
- Electromechanical relay output is UL rated for 5 amps resistive (250 Vac, 30 Vdc)
- Uses quick and easy IDC panel connection cable including the CBL2222P38C05L20 preterminated cable
- Provided with DIN rail mounting bracket or can be used as a panel mount module

**Product Selection**

Catalog Number	Input Type	Output Address B
8501SPX11	no physical input	electromechanical relay

**Dimensions**

Dimensions given include having the insulation displacement connector (IDC) in place. For details on IDC's see page 54.

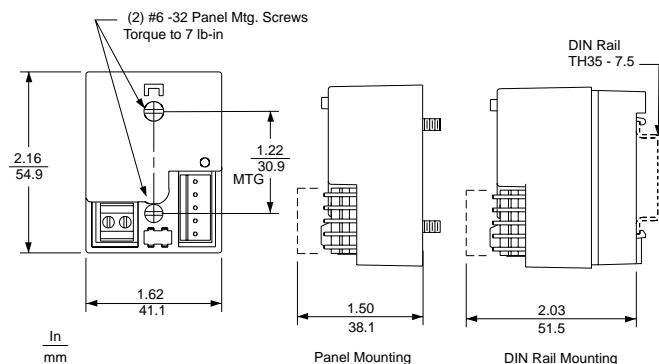

**Relay Characteristic Data**

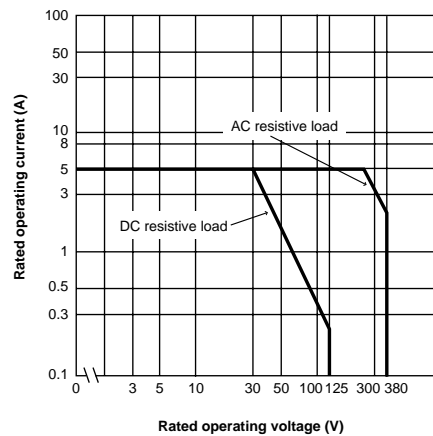

**Maximum switching capacity**

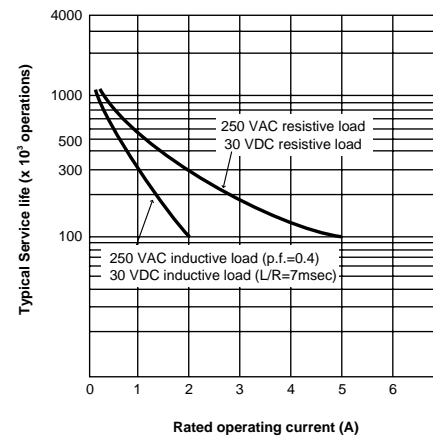

**Electrical service life**

SPXSST2 Set-Up Tool. . . . . page 48  
 Dedicated Module Panel Cabling . . . . . page 46  
 CPU Interface Cards . . . . . page 11  
 Power Supplies . . . . . page 6  
 System Overview. . . . . page 5 - 8



# SERIPLEX® Intelligent Wiring System

## Product Information — I/O Modules and Embedded Products

### Specifications

SERIPLEX bus power requirements: Nominal voltage rating Power supply voltage range at 25°C	24 Vdc 19.2 to 30 Vdc (including ripple)	
Bus power supply current drain (25°C, 24 Vdc)	16 mA typical	
Worst case bus power supply current drain (-25°C, 30 Vdc)	24mA	
Module capacitance	75 pF typical	
Bus clock frequency operating range	10 kHz to 200 kHz	
Operating temperature	-25 to +70°C (-13 to +158°F)	
Storage Temperature	-40 to +85°C (-40 to +185°F)	
Relative Humidity	5 to 95%, non-condensing	
UL Module and Relay Output Rating	250 Vac, 30 Vdc, 2.5 A resistive pilot duty: AC - 180VA, DC - 15 VA, C300	
Maximum Relay Rating	5A, 250 Vac General Use 5A, 30 Vdc Resistive 1/6 HP 250 Vac 1/8 HP 250 Vac 360W 120 Vac Tungsten	
Maximum Relay Operating Voltage	300 Vac, 125 Vdc	
Maximum Relay Operating Current	5 A	
Maximum Relay Switching Capacity	p.f. = 1 150W 1,250VA	p.f. = 0.4, L/R = 7 ms 60W 500VA
Relay Contact Material	AgCdO	
Micro-environmental category	II (per IEC664-1, Section 2.5.1)	
Shock (IEC 68-2-27)	30g, 3 axes, 11 ms duration, half sine pulse	
Vibration (IEC 68-2-6)	10 to 55 Hz, 1 mm peak-to-peak, 2 hour in 3 axes	
Noise immunity: Electrostatic Discharge (ESD) Radio Frequency Immunity (RFI) Fast transients Impulse	IEC801-2 IEC801-3 IEC801-4 IEC255-4	
Approvals	UL File E114926, CSA File LR53531	
Screw terminal block specifications conductor capacity	single conductor: UL 14 - 22 AWG, CSA 14 - 26 AWG	
Screw terminal torque	two conductors: 18 AWG - 28 AWG	
Fracture torque◆	0.4 N•m (3.5 lb. inches)	
Wire strip length	0.8 N•m (7.0 lb. inches) 7 mm (0.3 inches)	

◆ The fracture torque leads to damage of the screw shaft, stripping of the thread or deformation of the screw slot.

### Wiring and LED Indicators (8501SPX11)

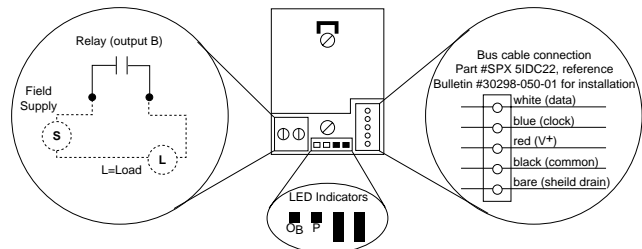

LED	Color	Function and Address
P	green	Bus Power Applied
O <sub>B</sub>	yellow	Output B Active

### Options, Replacement Parts and Accessories (8501SPX11)

Catalog Number	Description
SPXUSER2	Replacement user label (has marking surface for addresses and control words). Quantity 10.
8501NRSPX1	Replacement DIN mounting bracket for 8501 SPX11 relay
Add a 'T' to the end of a catalog number *	Conformal coating. Increases Micro-Environmental Category rating from MEC pollution degree II to MEC pollution degree III, as outlined in IEC 664-1, section 2.5.1. Conformal coating meets MIL-I-46058C.

\* To order conformal coating for catalog number 8501 SPX11, change to 8501 SPX11T.



# SERIPLEX® Intelligent Wiring System

## Product Information — I/O Modules and Embedded Products

### MEDIUM DENSITY DISCRETE I/O MODULES

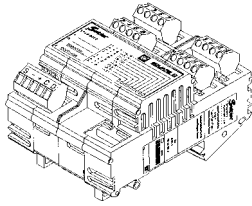

These discrete I/O modules provide an interface between the SERIPLEX control bus and external powered I/O devices. Modules can be interconnected and operated in peer-to-peer mode or networked for master/slave operation with a host CPU.

#### Features

- Eight inputs or eight outputs for each I/O module. Higher density I/O count makes installation and set-up simplified.
- Only one bus connection is needed for all eight I/O.
- Inputs are excellent for use with sensors.
- Outputs are used to switch valves and indicators.
- Addressing is simplified. Address A and B set the starting and ending address points for all 8 I/O, automatically setting the eight I/O module addresses.
- Complementary data retransmission (CDR) is a user setable option for the SPX08D50MAV2 eight-output I/O module.
- Peer-to-peer and master/slave operation are user setable options.
- LED's provide input and output status of individual I/O.
- A green LED indicates availability of control bus power. Aides with system start-up and troubleshooting.

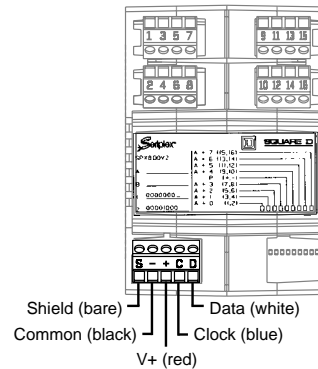

#### Options, Replacement Parts and Accessories

Catalog No.	Description
SPXJUMPA	Replacement jumper (for SPX08D50MAV2)
SPXPANEL	Optional mounting legs for panel-mounting of discrete I/O modules
SPXTERMBUS	Replacement terminal block - 5 terminals - bus connector markings (S, -, +, C, D)
SPXTERM2468A	Replacement almond (white) terminal block - 4 terminals (2, 4, 6, 8)
SPXTERM1357B	Replacement black terminal block - 4 terminals (1, 3, 5, 7)
SPXTERM1012A	Replacement almond (white) terminal block - 4 terminals (10, 12, 14, 16)
SPXTERM911B	Replacement black terminal block - 4 terminals (9, 11, 13, 15)
SPXUSER4	Replacement user label (has marking surface for address and control words) for SPX8D0V2 and SPX08D50MAV2. Quantity of 10 to a package.
Add a "T" to the end of the catalog number.	Conformal coating. Increases Micro-Environmental Category rating from MEC pollution degree 2 to MEC pollution degree 3 (per IEC664-1, section 2.5.1). Also meets MIL-I-46058C.

#### Product Selection

Catalog Number	Description
SPX8D0V2	Eight-input module.
SPX08D50MAV2	Eight-output module. Each output rated up to 50 mA.

#### Dimensions

Representative of both the SPX8D0V2 and the SPX08D50MAV2

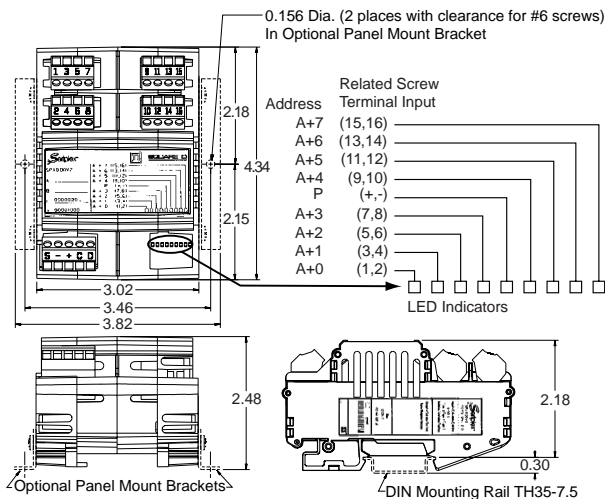

#### Control Bus Specifications

SERIPLEX bus power requirements	
nominal voltage rating	24 Vdc
power supply voltage range	19.2 - 30 Vdc (including ripple)
Bus power supply current drain (25°C, 24 Vdc)	
SPX8D0V2	40 mA typical
SPX08D50MAV2	60 mA typical
Worst-case bus power supply current drain (-25°C, 30 Vdc)	
SPX8D0V2	60 mA
SPX08D50MAV2	75 mA
Module capacitance	75 pF
Bus clock frequency operating range	10 - 192 kHz
Reverse polarity protection provided	Yes for + and - bus power leads

SPXSST2 Set-Up Tool	page 48
Cabling Components	page 39- 45
CPU Interface Cards	page 11
Power Supplies	page 6
System Overview	page 5 - 8



# SERIPLEX® Intelligent Wiring System

## Product Information — I/O Modules and Embedded Products

### General Specifications

Temperature ratings	
Operating	-25° to +70°C (-13° to +158°F)
Addressing and set-up	0° to +60°C (+32° to +140°F)
Storage	-40° to +80°C (-40° to +176°F)
Relative humidity	5 to 95%, non-condensing
Micro-environmental category	2 (per IEC664-1, Section 2.5.1)
Shock (IEC 68-2-27)	30 g, 3 axis, 11 ms duration, half-sine pulse
Vibration (IEC 68-2-6)	10 to 55 Hz, 1 mm peak-to-peak, 1/2 hour in 3 axis
I/O circuit isolation	
channel-to-channel	1,000 Vac
channel-to-bus	1,000 Vac
Electrical noise immunity	
Electrostatic Discharge	IEC 61000-4-2 Level 4 (8kV contact, 15kV air discharge)
Electromagnetic Field	IEC 61000-4-3 Level 3 (10V/m)
Fast Transient Burst	IEC 61000-4-4 Level 3 (2kV input power, 1kV control bus)
Surge Immunity	IEC 61000-4-5 Level 3 (2kV input power, 1kV control bus)
Conducted RFI	IEC 61000-4-6 Level 3 (10Vrms)
Approvals	UL File E114926 CSA File LR53531 IEC1131-2 (where applied to I/O) Factory Mutual (for Class 1, Division 2, Group A, B, C and D environments) 2D5A9.AX
Screw terminal conductor capacity	Single conductor: 12 AWG - 28 AWG Two conductors: 16 AWG - 28 AWG
Screw terminal torque	0.5 - 0.8 N•m (4.4 - 7.0 lb-in)
Fracture torque	1.1 N•m (9.6 lb-in)
Wire strip length	11 mm (0.43 inches)
Power / heat dissipation per module	5.5 W total (bus power, I/O conducting) 1.8 W bus power only (@30 Vdc)

### Input Specifications (SPX8D0V2)

Number of Inputs	8
Input type	Type 1 sensors (3-wire only)
Control Voltage	
Nominal	24 Vdc
Operating Voltage Range	11 to 30 Vdc polarity insensitive
Off-State Input Voltage	+5 Vdc $\geq$ Vin $\geq$ -5 Vdc
On-State Input Voltage	-11 Vdc $\leq$ Vin $\leq$ 11 Vdc
Maximum input current @ rated voltage	15 mA @ 30 Vdc
Maximum Allowable Off-State Leakage Current	0.5 mA
Off-to-On Response Time *	1 ms (max)
On-to-Off Response Time *	1 ms (max)
FM Temperature Rating	T4A

\*Turn-on/turn-off time is the electrical turn-on/turn-off time of the I/O module. Due to the nature of the SERIPLEX control bus, there is a possible delay before the signal will register on the SERIPLEX data line. The response time is a function of clock speed and frame size. See the SERIPLEX Design, Installation and Troubleshooting Manual (bulletin 30298-035-01).

### Output Specifications (SPX08D50MAV2)

Number of Outputs	8
Output type	Floating unipolar output circuit, sourcing or sinking
Control Voltage	
Nominal Voltage	24 Vdc
Operating Voltage Range	2 to 30 Vdc
Output current rating (per channel) @ 25°C bus down	50 mA DC continuous
Output current rating (per module) @ 25°C bus down	400 mA DC continuous
On-state voltage drop (terminal voltage)	1.5 Vdc @ rated current
Off-to-On Response Time *	0.5 ms (max)
On-to-Off Response Time *	0.5 ms (max)
FM Temperature Rating	T5

\* Turn-on/turn-off time is the electrical turn-on/turn-off time of the I/O module. Due to the nature of the SERIPLEX control bus, there is a possible delay before the signal will register on the SERIPLEX data line. The response time is a function of clock speed and frame size. See the SERIPLEX Design, Installation and Troubleshooting Manual (bulletin 30298-035-01).

Additional information of these products are available from the Internet at [www.squared.com](http://www.squared.com) or from the D-Fax system.

SPX8D0V2                      Bulletin #30298-037-01                      D-Fax #2950  
SPX08D50MAV2              Bulletin #30298-038-01                      D-Fax #2947

### SPX8D0V2

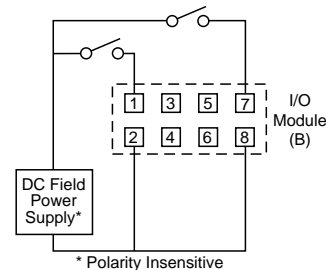

### Output Module Wiring — SPX08D50MAV2

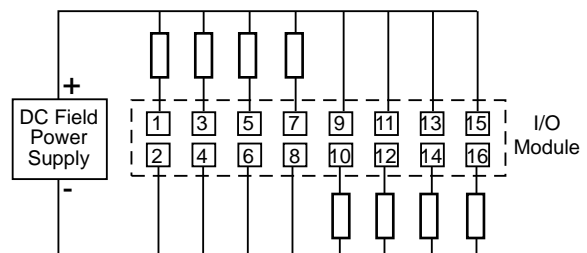

# SERIPLEX® Intelligent Wiring System

## Product Information — I/O Modules and Embedded Products

### FOUR-CHANNEL ANALOG INPUT MODULE

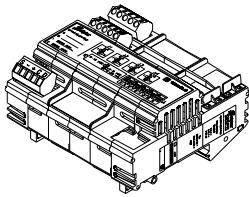

SERIPLEX analog input modules provide high-speed acquisition of analog input signals through the SERIPLEX control bus. A single SERIPLEX control bus can monitor and control up to 240 analog inputs and 240 analog outputs.

#### Features

- Four analog inputs per module
- Multiplexing used for greater address economy
- 12-bit differential analog signal resolution
- User selectable input ranges of: 0-5 Vdc, 0-10 Vdc or 0-20 mA
- Non-linearity  $\pm 0.02\%$  of full scale
- LED indicates control bus power is on and control bus is ready
- Isolation of 500V provided between the SERIPLEX control bus and the analog inputs
- Complementary Data Retransmission (CDR) is provided as a user settable option.

### Module Wiring Layout

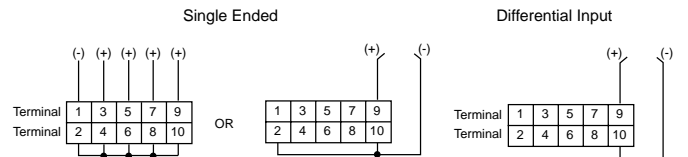
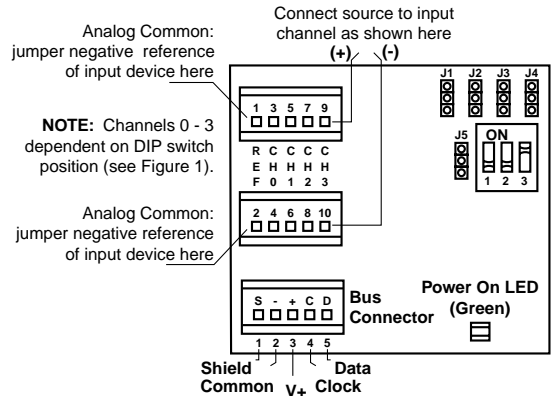

### Product Selection

Catalog Number	Number of Analog Inputs	Number of Analog Outputs	I/O Conversion Range
SPXAIN12X4V2	4	0	User selectable: 0-5 Vdc, 0-10 Vdc, 0-20 mA

### Dimensions

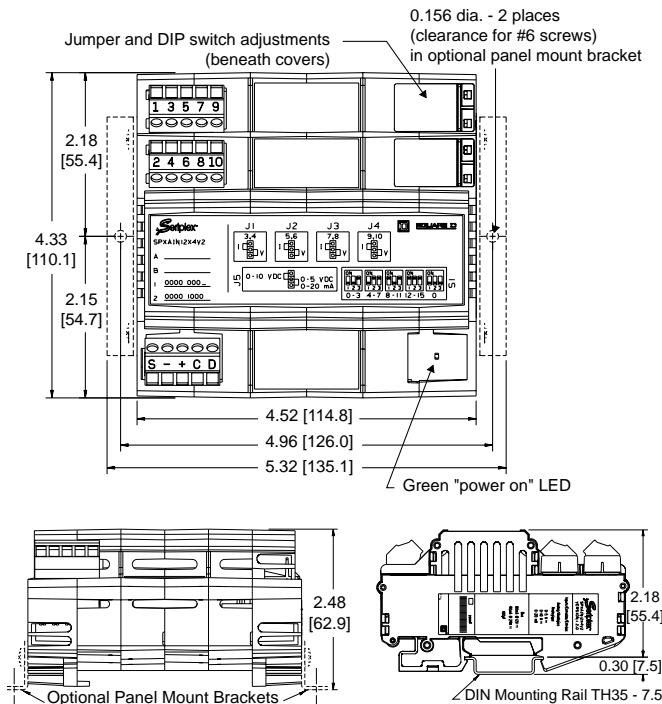

SPXSST2 Set-Up Tool . . . . .	page 48
Cabling Components . . . . .	page 39 - 45
CPU Interface Cards . . . . .	page 11
Power Supplies . . . . .	page 6
System Overview . . . . .	page 5 - 8



# SERIPLEX® Intelligent Wiring System

## Product Information — I/O Modules and Embedded Products

### Options, Replacement Parts and Accessories

Catalog Number	Description
SPXJUMPB	Replacement jumper (for SPXAIN12X4V2)
SPXPANEL	Optional mounting legs for panel-mounting of I/O modules
SPXTERMBUS	Replacement terminal block - 5 terminals - bus connector markings (S, -, +, C, D)
SPXTERM5ODD1B	Replacement black terminal block - 5 terminals (1, 3, 5, 7, 9)
SPXTERM5EVEN2A	Replacement almond (white) terminal block - 5 terminals (2, 4, 6, 8, 10)
SPXUSERS5	Replacement user label (has marking surface for address and control words) for SPXAIN12X4V2.
Add a "T" to the end of the catalog number	Conformal coating. Increases Micro-Environmental Category rating from MEC pollution degree 2 to MEC pollution degree 3 (per IEC664-1, section 2.5.1). Also meets MIL-I-46058C.

### Control Bus Specifications

SERIPLEX bus power requirements nominal voltage rating power supply voltage range	24 Vdc 10.5 to 15 Vdc and 19.2 to 30 Vdc (including ripple)
Nominal bus power supply current drain	80 mA at 12 Vdc 40 mA at 24 Vdc
Maximum power supply current drain @ 10.5 Vdc	≈90 mA at 25°C ≈148 mA over temperature range
Module capacitance	100 pF
Bus clock frequency operating range	10 to 192 kHz
Reverse polarity protection provided	Yes for + and - bus power leads

### General Specifications

Temperature ratings Operating Addressing and set-up Storage	-25° to +70°C (-13° to +158°F) 0° to +60°C (+32° to +140°F) -40° to +85°C (-40° to +185°F)
Relative humidity	5 to 95%, non-condensing
Micro-environmental category	2 (per IEC664-1, Section 2.5.1)
Shock (IEC 68-2-27)	30 g, 3 axis, 11 ms duration, half-sine pulse
Vibration (IEC 68-2-6)	10 to 55 Hz, 1 mm peak-to-peak, 1/2 hour in 3 axis
I/O circuit isolation channel-to-channel channel-to-bus	500 V 500 V
Electrical noise immunity Electrostatic Discharge Electromagnetic Field Fast Transient Burst	IEC 61000-4-2: 8kV contact or air discharge IEC 61000-4-3: 10V/m IEC 61000-4-4: 2 kV bus supply 1 kV clock & data 0.5 kV line-to-ground (I/O)
Surge Immunity bus supply clock & data	IEC 61000-4-5: 1 kV line-to-ground 0.5 kV line-to-line 1 kV shield-to-ground
Approvals	UL File E114926 CSA File LR53531 IEC1131-2 (where applied to I/O) Factory Mutual - T6 (for Class 1, Division 2, Group A, B, C and D environments) 2D5A9.AX
Screw terminal conductor capacity	Single conductor: 12 AWG to 28 AWG Two conductors: 16 AWG to 28 AWG
Screw terminal torque	0.5 - 0.8 N•m (4.4 - 7.0 lb-in)
Fracture torque	1.1 N•m (9.6 lb-in)
Wire strip length	11 mm (0.43 inches)
Power / heat dissipation per module	1.4 W total (bus power & inputs loaded) 1.0 W bus power only

### Input Specifications

Catalog number	SPXAIN12X4V2
Inputs per module	Four differential channels
Ranges (jumper selectable)	0 to 5 Vdc 0 to 10 Vdc 0 to 20 mA
Input impedance at 0 Vdc	2 MΩ, differential input 1 MΩ, single-ended input
Resolution	12-bit binary format, 4096 discrete increments
Nominal value of LSB (least significant bit)	0 to 5 Vdc range: 1.22 mV 0 to 10 Vdc range: 2.44 mV 0 to 20 mA range: 4.88 mA
Accuracy (single-ended operation, input negative reference jumpered to module analog common terminals 1 and 2)	Full scale error at 25°C 0 to 5 Vdc: ±0.22% 0 to 10 Vdc: ±0.40% 0 to 20 mA: ±0.50%
Nonlinearity	0.02%
Maximum input overload voltage	± 24 Vdc
Maximum input overload current	40 mA when using 0 to 20 mA current range
Current loop resistance	250Ω, +0.1%, +25 ppm/°C
Input impedance at 0 Vdc	2 MΩ, differential input 1 MΩ, single-ended input
Maximum input common mode voltage (no input terminal may exceed +12V with respect to analog common)	±12.0V at 0 Vdc differential input ±7.0V at 10 Vdc differential input ±9.5V at 5 Vdc differential input ±9.5V at 20 mA differential input
Common mode rejection ratio	100 dB typical at DC 50 dB worst case at 50 or 60 Hz @ 25°C
Data conversion time per channel	80 μs, minimum
Step input response time, 0 to 10 Vdc	27 milliseconds
Analog bandwidth of unit (-3 dB)	36 Hz
Input filter characteristics	First order
Operating mode	Bus clock synchronous

For additional information on this product, request bulletin #30298-043-01, available from the Internet at [www.squared.com](http://www.squared.com) or from Square D's DFAX line, document #2140.



# SERIPLEX® Intelligent Wiring System

## Product Information — I/O Modules and Embedded Products

### FOUR-CHANNEL ANALOG OUTPUT MODULE

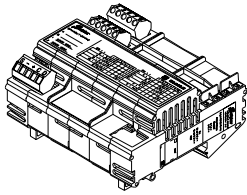

SERIPLEX analog output modules provide high-speed control of analog output signals through the SERIPLEX control bus. A single SERIPLEX control bus can monitor and control up to 240 analog inputs and 240 analog outputs.

#### Features

- Four analog outputs per module
- Multiplexing used for greater address economy
- 12-bit differential analog signal resolution
- User selectable output ranges of 0-5 Vdc or 0-10 Vdc
- Bipolar offsets of -2.5V, -3.3V, -5.0V and -10.0V available
- Relative output accuracy of  $\pm 0.25\%$  of full scale
- Differential non-linearity of  $\pm 0.1\%$  of full scale
- Status LED indicates control bus power is on and control bus is ready
- Isolation of 500V provided between the SERIPLEX control bus and the analog outputs
- Output zero and span are all factory set - no user adjustments needed. Will maintain published tolerances for the life of the module.
- Complementary Data Retransmission (CDR) is provided as a user setable option.
- User selectable output fault state: 0V, midpoint,  $V_{max}$ , or last known value.

#### Product Selection

Catalog Number	Number of Analog Inputs	Number of Analog Outputs	I/O Conversion Range
SPXAOUT12X4V2	0	4	User selectable: 0-5 Vdc 0-10 Vdc

#### Dimensions

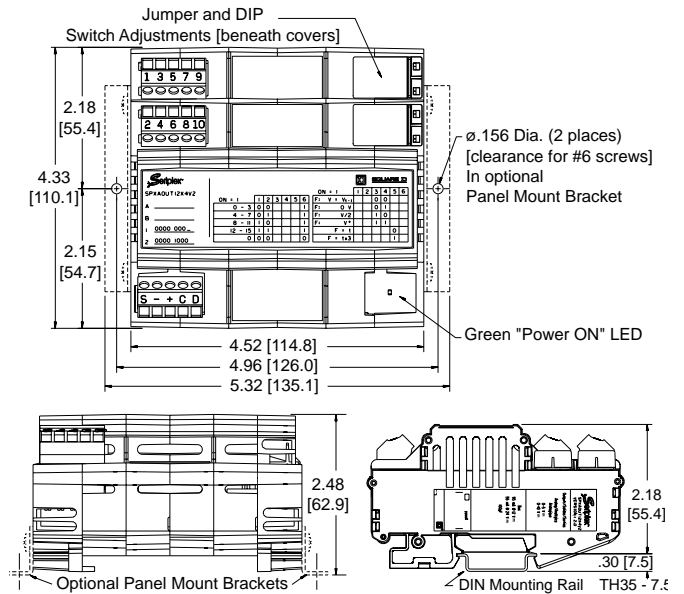

#### Module Wiring Layout

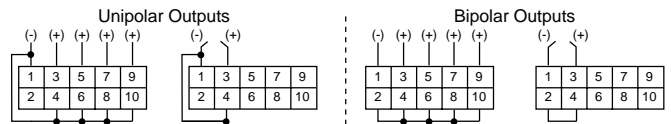
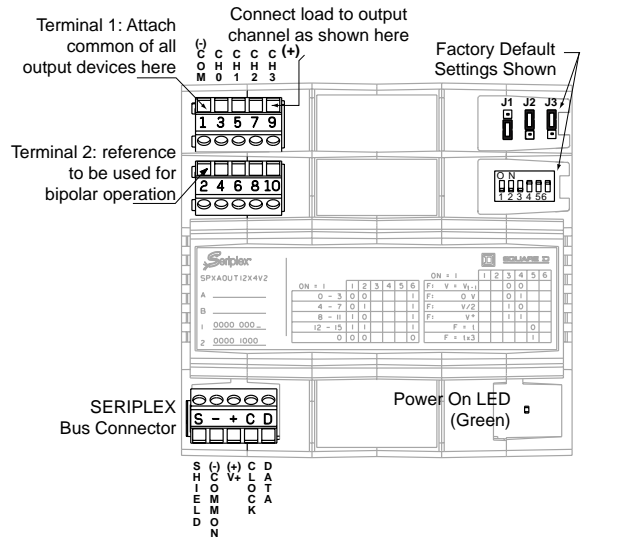

Note: in all cases, terminals 4,6,8,and 10 should be connected to terminals 1 or 2 or a user-supplied reference (remote sensing).

SPXSST2 Set-Up Tool .....	page 48
Cabling Components .....	page 39 - 45
CPU Interface Cards .....	page 11
Power Supplies .....	page 6
System Overview .....	page 5 - 8



# SERIPLEX® Intelligent Wiring System

## Product Information — I/O Modules and Embedded Products

### Options, Replacement Parts and Accessories

Catalog Number	Description
SPXJUMPB	Replacement jumper (for SPXAOUT12X4V2)
SPXPANEL	Optional mounting legs for panel-mounting of I/O modules
SPXTERMBUS	Replacement terminal block - 5 terminals - bus connector markings (S, -, +, C, D)
SPXTERM5ODD1B	Replacement black terminal block - 5 terminals (1, 3, 5, 7, 9)
SPXTERM5EVEN2A	Replacement almond (white) terminal block - 5 terminals (2, 4, 6, 8, 10)
SPXUSER6	Replacement user label (has marking surface for address and control words) for SPXAOUT12X4V2.
Add a "T" to the end of the catalog number	Conformal coating. Increases Micro-Environmental Category rating from MEC pollution degree 2 to MEC pollution degree 3 (per IEC664-1, section 2.5.1). Also meets MIL-I-46058C.

### Control Bus Specifications

SERIPLEX bus power requirements nominal voltage rating power supply voltage range	24 Vdc 10.5 - 15 Vdc and 19.2 - 30 Vdc (including ripple)
Nominal bus power supply current drain	95 mA at 12 Vdc 50 mA at 24 Vdc
Maximum power supply current drain @ 10.5 Vdc	≈110 mA at 25°C ≈148 mA over temperature range
Module capacitance	120 pF
Bus clock frequency operating range	10 to 192 kHz
Reverse polarity protection provided	Yes for + and - bus power leads

### General Specifications

Temperature ratings Operating Addressing and set-up Storage	-25° to +70°C (-13° to +158°F) 0° to +60°C (+32° to +140°F) -40° to +85°C (-40° to +185°F)
Relative humidity	5 to 95%, non-condensing
Micro-environmental category	2 (per IEC664-1, Section 2.5.1)
Shock (IEC 68-2-27)	30 g, 3 axis, 11 ms duration, half-sine pulse
Vibration (IEC 68-2-6)	10 to 55 Hz, 1 mm peak-to-peak, 1/2 hour in 3 axis
I/O circuit isolation channel-to-channel channel-to-bus	500 V 500 V
Electrical noise immunity Electrostatic Discharge Electromagnetic Field Fast Transient Burst	IEC 61000-4-2: 8kV contact or air discharge IEC 61000-4-3: 10V/m IEC 61000-4-4: 2 kV bus supply 1 kV clock & data 0.5 kV line-to-ground (I/O)
Surge Immunity	IEC 61000-4-5: 1 kV line-to-ground 0.5 kV line-to-line
Approvals	UL File E114926 CSA File LR53531 IEC1131-2 (where applied to I/O) Factory Mutual - T6 (for Class 1, Division 2, Group A, B, C and D environments)
Screw terminal conductor capacity	Single conductor: 12 AWG - 28 AWG Two conductors: 16 AWG - 28 AWG
Screw terminal torque	0.5 - 0.8 N•m (4.4 - 7.0 lb-in)
Fracture torque	1.1 N•m (9.6 lb-in)
Wire strip length	11 mm (0.43 inches)
Power / heat dissipation per module	1.7 W total (bus power & outputs loaded) 1.1 W bus power only

### Output Specifications

Catalog number	SPXAOUT12X4V2
Outputs per module	Four differential channels
Ranges (jumper selectable)	0 to 5 Vdc 0 to 10 Vdc
Output impedance in signal range	1 Ω
Resolution	12-bit binary format, 4096 discrete increments
Nominal value of LSB (least significant bit)	0 to 5 Vdc range: 1.22 mV 0 to 10 Vdc range: 2.44 mV
Accuracy	±0.25% of full scale at 25°C ±0.006% of full scale / °C
Total output system transfer time	dependent on bus clock frequency
Settling time for full range change	<100 μs
Overshoot	<10% of full scale
Type of protection	Opto-isolators for bus clock and data lines. Transformer for bus power.
Type and length of output cable for noise immunity	Shielded twisted pair, 50 meters maximum
Common points between channels	Terminal 1
Allowed types of loads	Floating. All four outputs must be referenced to common.
Maximum capacitive load	9,000 pF
Output response at power up and power down	monotonic
Monotonicity	Yes
Crosstalk between channels	≈80 dB (DC to 1 kHz)
Non-linearity	0.1% of full scale
Repeatability at fixed temperature after specified stabilization time	<0.01% of full scale
Short circuit current at 25°C	22 mA typical each output

For additional information on this product, request bulletin #30298-042-01, available from the Internet at [www.squared.com](http://www.squared.com) or from Square D's DFAX line, document #2948.



# SERIPLEX® Intelligent Wiring System

## Product Information — I/O Modules and Embedded Products

### HIGH DENSITY DISCRETE I/O BOARDS

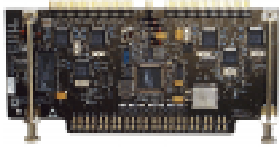

SERIPLEX high-density digital I/O boards provide high-speed acquisition and control of digital input and output signals through the SERIPLEX control bus. A single SERIPLEX control bus can monitor and control up to

3,840 digital inputs and 3,840 digital outputs. The digital I/O board is an open chassis device. This I/O board does not contain the bus fault detection (BFD) or complementary data retransmission (CDR) features. Contact your local Square D sales office for additional information.

#### Features

- One board handles 24 inputs and 24 outputs
- User setable multiplexing option provides control bus address economy
- Provides single-ended digital inputs with reverse bias protection
- Provides open collector digital outputs with transient voltage and short circuit protection
- Individual LED status indicator for each input and each output
- A green status LED indicates control bus power on and control bus ready
- Simplifies board diagnostics with available onboard header pin for oscilloscope (frame) synchronization
- Operates in master/slave or peer-to-peer mode

#### Product Selection

Catalog Number	Description
SPX24D0	High density board with 24 discrete inputs
SPX024D200MA	High density board with 24 discrete outputs
SPX24D24D200MA	High density board with 24 discrete inputs + 24 discrete outputs

#### Dimensions

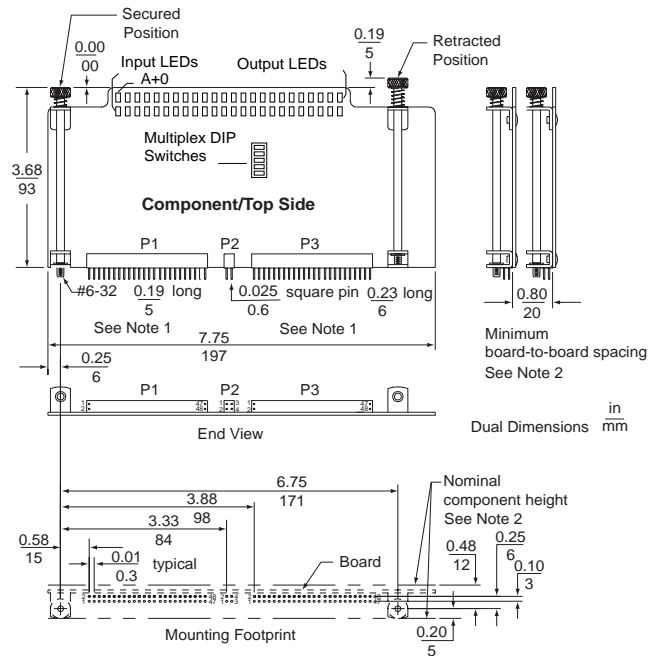

#### Notes:

- 1 Positioned for socket 0.04" (1mm) shorter than threaded standoff. Standoff to be 0.25" (6mm) minimum diameter.
- 2 Minimum spacing. More spacing may be required for thermal allowances, vibrational allowances, and ease of installation.

#### Options, Replacement Parts and Accessories

Catalog Number	Description
IBCBLADAPT	SPXSST2 Set-Up Tool cable adaptor. Fits: SPXHH2A2CABLE set-up cable SPXHH2Y2CABLE set-up cable

#### Control Bus Specifications

SERIPLEX bus power requirements nominal voltage rating power supply voltage range	24 Vdc 10.5 - 15 Vdc and 19.2 - 30 Vdc (including ripple)
Bus power supply current drain	28 mA typical 62 mA worst case
Module capacitance	175 pF
Bus clock frequency operating range	10 - 192 kHz
Time delay at start-up or fault clear	5 data frames
Reverse polarity protection provided	Yes for + and - bus power leads

SPXSST2 Set-Up Tool . . . . . page 48  
 Cabling Components . . . . . page 39 - 45  
 CPU Interface Cards . . . . . page 11  
 Power Supplies . . . . . page 6  
 System Overview . . . . . page 5 - 8



# SERIPLEX® Intelligent Wiring System

## Product Information — I/O Modules and Embedded Products

### General Specifications

Temperature ratings	
Operating	0° to +70°C (+32° to +158°F)
Addressing and set-up	0° to +60°C (+32° to +140°F)
Storage	-40° to +85°C (-40° to +185°F)
Relative humidity	5 to 95%, non-condensing
Micro-environmental category	II (per IEC664-1, Section 2.5.1)
Isolation	
inputs-to-outputs	none
channel-to-channel	none
channel-to-bus	1,500 Vac
Shock (IEC 68-2-27)	30 g, 3 axes, 11 ms duration, half-sine pulse
Vibration (IEC 68-2-6)	10 to 55 Hz, 1 mm peak-to-peak, 30 minutes in 3 axes
Power/heat dissipation per unit	17 W (worst case, all I/O conducting)

### Electrical Robustness Levels

IEC Standard	Description	Test Level	Network Power Supply	Network Communication Lines	+24 Vdc Power Supply	Digital I/O Circuits
61000-4-2	Electrostatic discharge (ESD)	4	8 kV contact discharge	8 kV contact discharge	8 kV contact discharge	2 kV contact discharge
61000-4-3	Electromagnetic field	3	10 V/m	10 V/m	10 V/m	10 V/m
61000-4-4	Fast transient/burst	→	Level 3 2 kV ❖	Level 3 1 kV ❖	Level 2 1 kV	Level 3 1 kV
61000-4-5	Surge immunity	→	Level 2 1 kV CM 500 V DM	Level 3 2 kV CM ▲ NA	Level 1 500 V CM 250 V DM	NA
60255-4	Impulse voltage withstand	→	NA	NA	NA	Class II > 1.0 kV

- ❖ Coupled through a capacitive clamp.
- ▲ Only the shield is subjected to surge.

### Typical Wiring Diagrams for both I & O

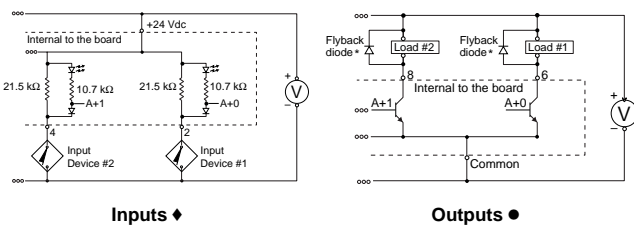

- ◆ Devices must be current sinking types only.
- Loads are negative switching types only.

### Input Specifications

Number of Inputs	24
Input type	Single ended, pulldown
Operating Input Voltage	+24 Vdc ±10% (including ripple)
Off-State Input Voltage	2 Vdc or less
On-State Input Voltage	19 Vdc or more
Maximum input current @ rated voltage	8 mA
Input protection	Reverse bias protection
Off-to-On Response Time*	350 μs nominal 625 μs worst case
On-to-Off Response Time*	350 μs nominal 625 μs worst case

### Output Specifications

Number of Outputs	24
Output type	Common emitter (requires a current-sourcing type load)
Operating output voltage range	+24 Vdc ±10% (including ripple)
Output current rating	per channel: 200 mA per board: 2.4 amps
Maximum off-state leakage current	100 μA
On-state voltage drop (max at 25°C)	0.5 Vdc @ 200 mA
Off-to-On Response Time *	10 μs nominal 20 μs worst case
On-to-Off Response Time *	10 μs nominal 20 μs worst case

- \* Turn-on/turn-off time is the electrical turn-on/turn-off time of the I/O module. Due to the nature of the SERIPLEX control bus, there is a possible delay before the signal will register on the SERIPLEX data line. The response time is a function of clock speed and frame size. See the SERIPLEX Design, Installation and Troubleshooting Manual (bulletin 30298-035-01).

### Field I/O Power Supply Requirements

Power supply voltage range	+24 Vdc ±10% (including ripple)
Maximum power supply current drain	300 mA for board and I/O, excluding load current draw

For additional information on this product, request bulletin #8330DB9804, available from the Internet at [www.squared.com](http://www.squared.com) or from the Square D, D-Fax line, #168.



# SERIPLEX® Intelligent Wiring System

## Product Information — I/O Modules and Embedded Products

### HIGH DENSITY ANALOG I/O BOARDS

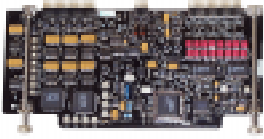

SERIPLEX high-density analog I/O boards are open-chassis devices providing high-speed acquisition and control of analog input and output signals through the SERIPLEX control bus. A single SERIPLEX control bus

can monitor and control up to 240 analog inputs and 240 analog outputs. This I/O board does not contain the bus fault detection (BFD) or complementary data retransmission (CDR) features. Contact your local Square D sales office for additional information.

#### Features

- Up to 16 analog inputs plus 16 analog outputs per board
- Multiplexing used for greater address economy
- 12-bit differential, analog signal resolution
- Relative accuracy (inputs or outputs) of  $\pm 0.05\%$  of full scale
- Differential non-linearity (inputs or outputs) of  $\pm 0.02\%$  of full scale
- Full-scale error of  $\pm 0.1\%$  @ 25°C,  $\pm 30$  ppm/°C over temperature
- Green status LED indicates control bus power is on and control bus is ready
- Optical isolation of 1,500 Vac between the SERIPLEX control bus and the analog I/O points
- Zero and span adjustments are all factory set - no user adjustments needed
- Overvoltage protection provided for +15 and -15 Vdc supply inputs
- Onboard header pin for oscilloscope (frame) synchronization, to simplify board diagnostics
- Individual output reference terminals allow for user provided d.c. offsets. Also allows cancellation of both hum and ground potential differences at the load termination point.

#### Product Selection

Catalog Number	Number of Analog Inputs	Number of Analog Outputs	I/O Conversion Range
SPXAIN12X8A	8	0	0 - 5 Vdc
SPXAIN12X8B	8	0	0 - 10 Vdc
SPXAIN12X16A	16	0	0 - 5 Vdc
SPXAIN12X16B	16	0	0 - 10 Vdc
SPXAOUT12X8A	0	8	0 - 5 Vdc
SPXAOUT12X8B	0	8	0 - 10 Vdc
SPXAI012X8A	8	8	0 - 5 Vdc
SPXAI012X8B	8	8	0 - 10 Vdc
SPXAIO12X16A	0	16	0 - 5 Vdc
SPXAIO12X16B	0	16	0 - 10 Vdc
SPXAI012X16A	16	16	0 - 5 Vdc
SPXAI012X16B	16	16	0 - 10 Vdc

### Dimensions

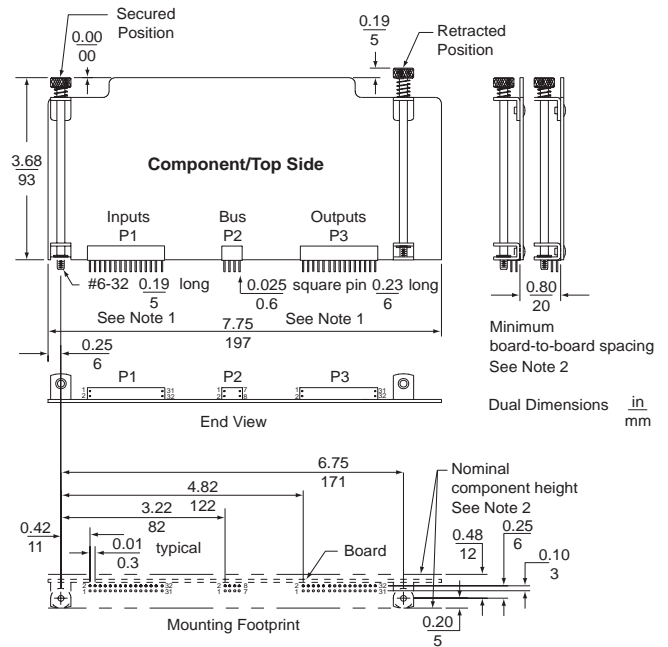

#### Notes:

- 1 Positioned for socket 0.04"(1mm) shorter than threaded standoff. Standoff to be 0.25"(6mm) minimum diameter.
- 2 Minimum spacing. More spacing may be required for thermal allowances, vibrational allowances, and ease of installation.

### Operational Block Diagram

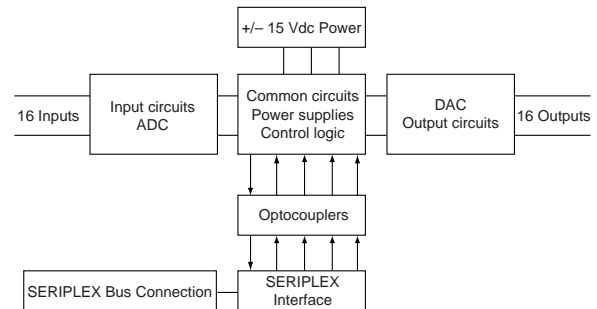

### Equivalent I/O Circuits

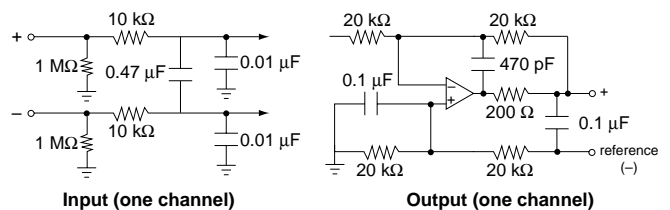

SPXSST2 Set-Up Tool ..... page 48  
 Cabling Components ..... page 39 - 45  
 CPU Interface Cards ..... page 11  
 Power Supplies ..... page 6  
 System Overview ..... page 5 - 8



# SERIPLEX® Intelligent Wiring System

## Product Information — I/O Modules and Embedded Products

### Options, Replacement Parts and Accessories

Catalog Number	Description
IBCLADAPT	SPXSST2 Set-Up Tool cable adaptor. Fits either: SPXHH2A2CABLE set-up cable or SPXHH2Y2CABLE set-up cable

### Control Bus Specifications

SERIPLEX bus power requirements nominal voltage rating power supply voltage range	24 Vdc 10.5 - 15 Vdc and 19.2 - 30 Vdc (including ripple)
Bus power supply current drain	25 mA maximum
Module capacitance	90 pF
Bus clock frequency operating range	10 - 192 kHz
Time delay at start-up or fault clear	5 data frames
Reverse polarity protection provided	Yes for + and - bus power leads

### General Specifications

Temperature ratings Operating Addressing and set-up Storage	0° to +70°C (+32° to +158°F) 0° to +60°C (+32° to +140°F) -40° to +85°C (-40° to +185°F)
Relative humidity	5 to 95%, non-condensing
Micro-environmental category	2 (per IEC664-1, Section 2.5.1)
Isolation inputs-to-outputs channel-to-channel channel-to-bus	none none 1,500 Vac
Shock (IEC 68-2-27)	30 g, 3 axes, 11 ms duration, half-sine pulse
Vibration (IEC 68-2-6)	10 to 55 Hz, 1 mm peak-to-peak, 30 minutes in 3 axes
Power/heat dissipation per unit	1.5 W (worst case, no outputs loaded)

### Electrical Robustness Levels

IEC Standard	Description	Test Level	Network Power Supply	Network Communication Lines	Analog I/O Power Supply	Analog I/O Circuits
61000-4-2	Electrostatic discharge (ESD)	4	8 kV contact discharge	8 kV contact discharge	8 kV contact discharge	2 kV contact discharge
61000-4-3	Electromagnetic field	3	10 V/m	10 V/m	10 V/m	10 V/m
61000-4-4	Fast transient/burst	→	Level 3 2 kV	Level 3 1 kV ❖	Level 2 1 kV	Level 3 1 kV
61000-4-5	Surge	→	Level 2 1 kV CM 500 V DM	Level 3 2 kV CM * NA DM	Level 1 500 V CM 250 V DM	NA
60255-4	Impulse voltage withstand	→	NA	NA	NA	Class II >1.0 kV
61000-4-6	Conducted RFI (radio frequency immunity)	3	10 Vrms	10 Vrms	10 Vrms	10 Vrms

- ❖ Coupled through a capacitive clamp.
- \* Only the shield is subjected to surge.

### Input Specifications

Input type and resolution	Differential, non-isolated, 12-bit unsigned, 4096 discrete increments
Ranges	Suffix A versions: 0 to 5 Vdc Suffix B versions: 0 to 10 Vdc
Value of LSB (nominal)	0 to 5 Vdc range: 1.22 mV 0 to 10 Vdc range: 2.44 mV
Full scale error	±0.1% at 25°C ±30 ppm/°C over temperature range
Relative accuracy	±0.05% of full scale
Differential non-linearity	±0.02% of full scale
Maximum load (input common mode voltage)	11 V (any input terminal with respect to analog common)
Miswiring or overvoltage protection	None

### Output Specifications

Output type and resolution	Differential, non-isolated, 12-bit unsigned, 4096 discrete increments
Ranges	Suffix A versions: 0 to 5 Vdc Suffix B versions: 0 to 10 Vdc
Value of LSB (nominal)	0 to 5 Vdc range: 1.22 mV 0 to 10 Vdc range: 2.44 mV
Full scale error	±0.1% at 25°C ±30 ppm/°C over temperature range
Relative accuracy	±0.05% of full scale
Differential non-linearity	±0.02% of full scale
Maximum load (maximum output current)	5 mA
Maximum capacitive load	9,000 pF
Short circuit current	22 mA typical at 25°C
Max output common mode voltage	11 V (any output terminal with respect to analog common)
Output settling time	0 - 5 Vdc range: 75 µs typical 0 - 10 Vdc range: 150 µs typical
Output overshoot (typical)	none

### Analog I/O Power Supply Specifications

Analog I/O channel power supply +15 Vdc -15 Vdc	Voltage range and maximum supply current drain +14 to +16 Vdc (including ripple), 200 mA -14 to -16 Vdc (including ripple), 120 mA
---	--

For additional information on this product, request bulletin #8330DB9801, available from the Internet at [www.squared.com](http://www.squared.com) or from the Square D D-Fax line, #991.



# SERIPLEX® Intelligent Wiring System

## Product Information — I/O Modules and Embedded Products

### DEDICATED 30MM PUSH BUTTON MODULES

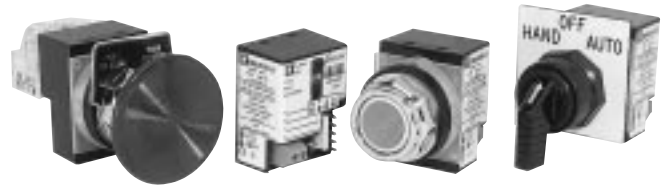
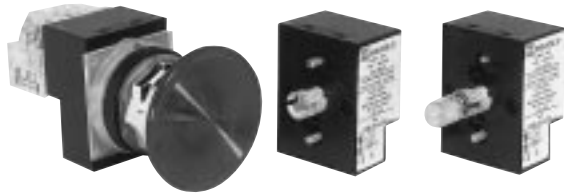

The **Class 9001 Dedicated Module for 30mm Push Buttons** provides an interface between the SERIPLEX control bus and any of the Square D Class 9001 Type K, SK, KX and T push buttons, pilot lights and selector switches (exceptions: 5-position joy stick and Type KX multi-lamp operators). Single-bit bus interface circuitry is used in this module. If multiplexed operation is used by the CPU interface card, the push button module is scanned every frame. This adaptor module is not capable of being multiplexed.

#### Features

- Can be used with any Type K, SK, KX or T push button, pilot light or selector switch operator (exceptions: 5-position joy stick operators and Type KX multi-lamp operators)
- Performs control for illuminated and non-illuminated push button operators
- Relay output dedicated modules are for illuminated operators with a standard Type KM light module
- Bus powered lamp modules don't require an auxiliary power supply or additional power conductors
- Bus powered lamp modules use high visibility, low current consumption LED lamps, providing long life and greater system flexibility
- LED indicators provided on all modules showing power-on status, input status and output status -- a convenient installation and troubleshooting aide
- Modules use quick and easy IDC panel cabling including preterminated cable (Catalog #CBL2222P38C05L20)

#### Assembly and Dimensions

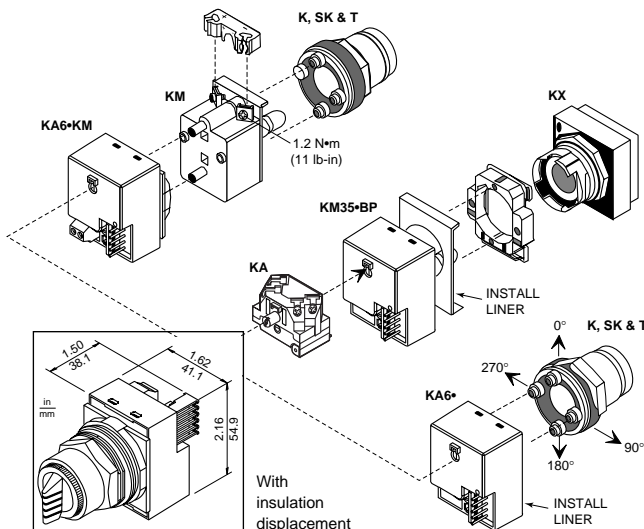

*NOTE: Selection tables are for SERIPLEX modules only. Order push button operators separately.*

#### For Non-Illuminated Operators

Catalog Number	Input Type Address A	Input Type Address B	Output Type
9001KA61	N.C.	N.O.	none
9001KA62	—	N.O.	none
9001KA63	N.C.	—	none

#### For Illuminated Operators Using a Type KM Light Module

Catalog Number	Input Type Address A	Input Type Address B	Output Type Address B
9001KA60KM	—	—	Electromechanical Relay ♦
9001KA61KM	N.C.	N.O.	Electromechanical Relay ♦
9001KA62KM	—	N.O.	Electromechanical Relay ♦
9001KA63KM	N.C.	—	Electromechanical Relay ♦

♦ See page 15-16 for general purpose ratings.

#### Bus Powered LED Lamps for Illuminated Operators (LED lamps are included)

Catalog Number	Input Type Address A	Input Type Address B	Output Type Address B
9001KM350BPA	—	—	LED Lamp - Amber
9001KM350BPG	—	—	LED Lamp - Green
9001KM350BPR	—	—	LED Lamp - Red
9001KM351BPA	N.C.	N.O.	LED Lamp - Amber
9001KM351BPG	N.C.	N.O.	LED Lamp - Green
9001KM351BPR	N.C.	N.O.	LED Lamp - Red
9001KM352BPA	—	N.O.	LED Lamp - Amber
9001KM352BPG	—	N.O.	LED Lamp - Green
9001KM352BPR	—	N.O.	LED Lamp - Red
9001KM353BPA	N.C.	—	LED Lamp - Amber
9001KM353BPG	N.C.	—	LED Lamp - Green
9001KM353BPR	N.C.	—	LED Lamp - Red

#### Selector Switch Logic Table

Cam Type	Class 9001 Operator Type						
	KS42	KS43	KS44	KS11 KS25	KS46	KS88	KS87 KS88 KS89
Knob Position	1 2 3	1 2 3	1 2 3	1 2	1 2 3	1 2 3 4	1 2 3 4
Address A (N.C.)	0 0 x	x 0 0	0 0 x	x 0	x 0 0	x 0 0 0	0 x 0 0
Address B (N.O.)	0 x x	0 0 x	0 x 0	0 x	0 0 x	0 x 0 0	0 0 x x

Contacts Closed = x

Contacts Open = o

SPXSST2 Set-Up Tool . . . . . page 48  
 Cabling Components . . . . . page 39 - 45  
 CPU Interface Cards . . . . . page 11  
 Power Supplies . . . . . page 6  
 System Overview . . . . . page 5 - 8



# SERIPLEX® Intelligent Wiring System

## Product Information — I/O Modules and Embedded Products

### Options, Replacement Parts and Accessories

Catalog Number	Description
<b>SPX30MMXCAM</b>	4-position selector switch cam for use with SERIPLEX modules for 30mm operators
<b>SPXLEDA1</b>	Replacement LED Lamp – amber
<b>SPXLEDG1</b>	Replacement LED Lamp – green
<b>SPXLEDR1</b>	Replacement LED Lamp – red
<b>SPXUSER2</b>	Replacement user label (has marking surface for addresses and control words). Quantity 10.
<b>9001KXALLRT</b>	Lamp Removal Tool
Add a 'T' to the end of a catalog number *	Conformal coating. Increases Micro-Environmental Category rating from MEC pollution degree II to MEC pollution degree III, as outlined in IEC 664-1, section 2.5.1. Conformal coating meets MIL-I-46058C.

\* Example: To order conformal coating for catalog number 9001 KA61, change to 9001 KA61T.

### Specifications

SERIPLEX bus power requirements: Nominal voltage rating Power supply voltage range at 25°C	24 Vdc 19.2 to 30 Vdc including ripple
Bus power supply current drain (25°C, 24 Vdc)	no relay output: 7 mA typical relay output: 16 mA typical bus powered LED lamp: 18 mA typical
Worst case bus power supply current drain (-25°C, 30 Vdc)	no relay output: 8 mA relay output: 24 mA bus powered LED lamp: 24 mA
Module capacitance	75 pF typical
Bus clock frequency operating range	10 kHz to 200 kHz
Operating temperature	-25 to +70°C (-13 to +158°F)
Storage Temperature	-40 to +85°C (-40 to +185°F)
Relative Humidity	5 to 95%, non-condensing
Electromechanical Relay Rating (UL)	250 Vac, 30 Vdc, 2.5 A resistive pilot duty: AC - 180VA, DC - 15 VA, C300
Micro-environmental category	II (per IEC664-1, Section 2.5.1)
Shock (IEC 68-2-27)	30g, 3 axes, 11 ms duration, half sine pulse
Vibration (IEC 68-2-6)	10 to 55 Hz, 1 mm peak-to-peak, 2 hour in 3 axes
Noise immunity: Electrostatic Discharge (ESD) Radio Frequency Immunity (RFI) Fast transients Impulse	IEC801-2 IEC801-3 IEC801-4 IEC255-4
Approvals	UL File E114926, CSA File LR53531-20, CE, FM
Screw terminal block specifications (relay versions only) conductor capacity	single conductor: UL 14 - 22 AWG, CSA 14 - 26 AWG two conductors: 18 AWG - 28 AWG
Screw terminal torque Fracture torque ♦ Wire strip length	0.4 N•m (3.5 lb. inches) 0.8 N•m (7.0 lb. inches) 7 mm (0.3 inches)
Maximum allowable standard contact blocks mounted on a SERIPLEX dedicated module	One Contact Block (Class 9001 Type KA1 through Class 9001 Type KA6)

♦ The fracture torque leads to damage of the screw shaft, stripping of the thread or deformation of the screw slot.

### Wiring and LED Indicators

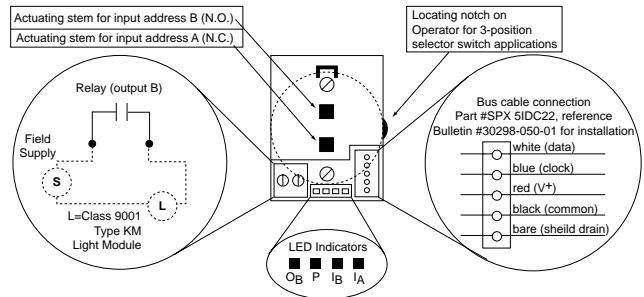

LED	Color	Function and Address
I <sub>A</sub>	yellow	Input A Active
I <sub>B</sub>	yellow	Input B Active
P	green	Bus Power Applied
O <sub>B</sub>	yellow	Output B Active



# SERIPLEX® Intelligent Wiring System

## Product Information — I/O Modules and Embedded Products

### Assembly and Dimensions

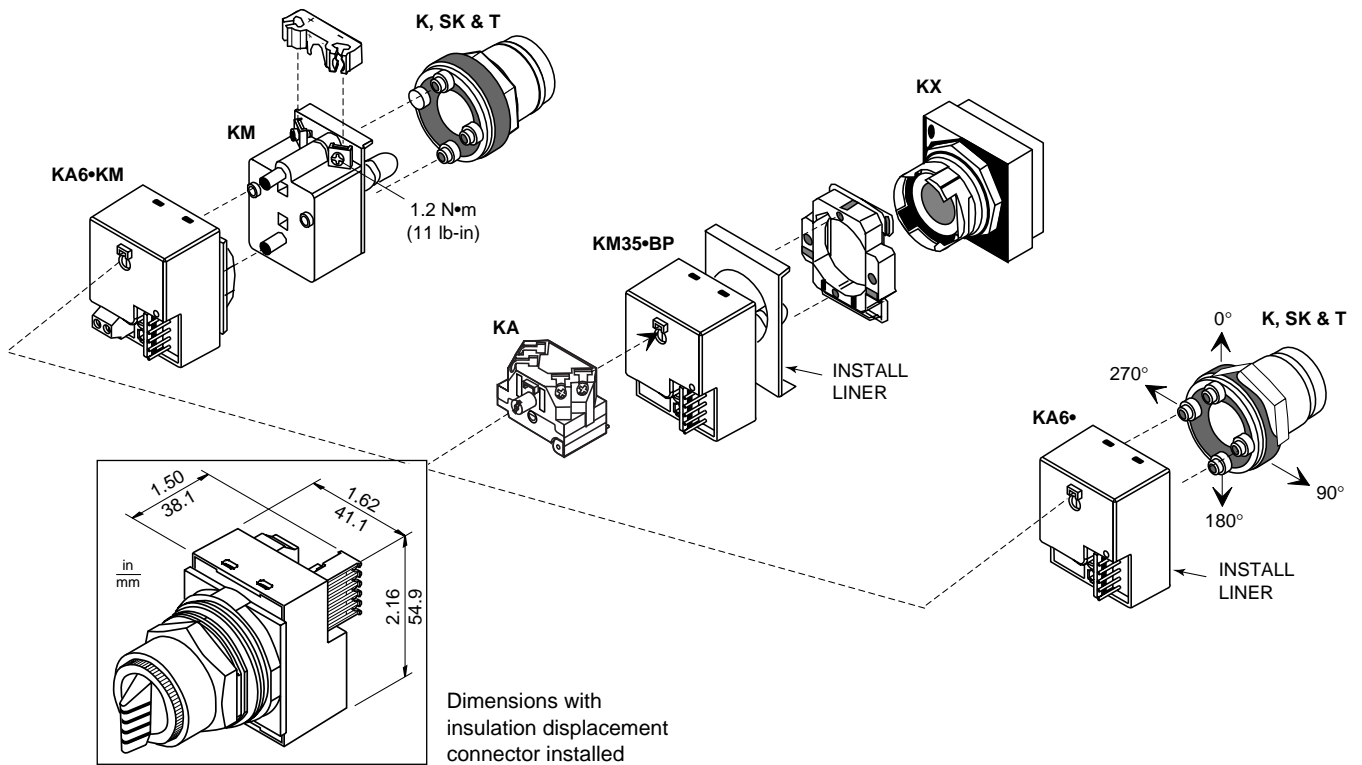

Two inputs, one LED lamp output, and one quick control bus connection.



Two, three, and four position selector switch operators. SERIPLEX 30mm push button modules fit most Type K, SK, KX, T illuminated and non-illuminated operators.



For “emergency-stop” applications, a standard Type KA contact block is mounted to the push button module. The Type KA block provides a direct acting hard contact break required by code for “e-stop” applications, while the SERIPLEX module provides a quick indication (to the host) of the “e-stop” signal location. This application is good for long conveyors and other industrial uses where numerous “e-stop” locations are required.

### SERIPLEX Control Bus Wiring System



With preterminated cable, wiring a panel is simplified



**SERIPLEX® Intelligent Wiring System**  
**Product Information — I/O Modules and Embedded Products**

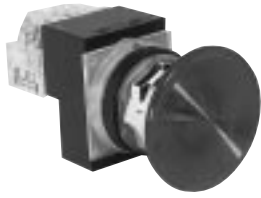

**LEGEND PLATE**



**+**  
**OPERATOR**



**+**  
**LIGHT MODULE**  
(if necessary)



**+**  
**SERIPLEX BLOCK**



**= COMPLETE UNIT**

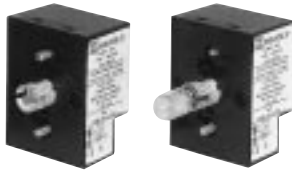

**LEGEND PLATE**



**+**  
**OPERATOR**



**+**  
**SERIPLEX LIGHT MODULE**



**OR**  
**SERIPLEX BLOCK**



**= COMPLETE UNIT**

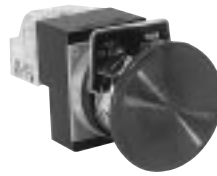

**LEGEND PLATE**



**+**  
**OPERATOR**



**+**  
**LIGHT MODULE**  
(if necessary)



**+**  
**SERIPLEX BLOCK**



**= COMPLETE UNIT**

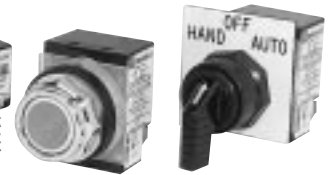

**LEGEND PLATE**



**+**  
**OPERATOR**



Standard      Gloved Hand

**+**  
**SERIPLEX LIGHT MODULE**



**OR**  
**SERIPLEX BLOCK**



**= COMPLETE UNIT**

**LEGEND PLATE**



**OPERATOR**



**LIGHT MODULE**



**= COMPLETE UNIT**

*NOTE: For full operator selection, see Digest 172 Section 16.*

# SERIPLEX® Intelligent Wiring System

## Product Information — I/O Modules and Embedded Products

### MATERIAL PULL PENDANT STATIONS

The **Material Pull Pendant Stations** provide an interface between the SERIPLEX control bus and a single input push button operator enclosed in a pendant station. Single-bit bus interface circuitry is used in this unit. If multiplexed operation is used by the CPU interface card, the pendant is scanned every frame. This pendant is not capable of being multiplexed.

#### Features

- Durable enclosure rated NEMA Type 12
- Bus powered lamp modules don't require an auxiliary power supply or additional power conductors
- Bus powered lamp modules use high visibility, low current consumption LED lamps, providing long life and greater system flexibility
- Mini-style quick-change connectors provide for easy pendant installation and change out
- LED indicators provided on the SERIPLEX module show power-on status, input status and output status – a convenient installation and troubleshooting aide

#### About Material Pull Systems

A SERIPLEX Material Pull Pendant is used to control the floor stock of parts being installed during a final assembly operation. Typically, as an assembly worker uses parts they monitor the stock of material being used. When stock falls to a predetermined level, the assembly worker pushes the button on the Material Pull Pendant and a signal is sent to the computer requesting parts for that specific assembly operation. The illuminated push button in the pendant flashes to indicate the location where the parts are needed and a lift truck driver is dispatched with the parts. The lift truck driver presses the pendant push button to indicate that the parts have been delivered and to reset the system.

#### Product Selection

Catalog Number	Input Address A	Input Address B	Output Address B	Description
SPXBWPEND5	health bit (optional)	N.O.	LED Lamp - Amber	Pendant enclosure, single illuminated push button, bus powered amber LED lamp.
9001AEQ3370	health bit (optional)	N.O.	LED Indicator - Red	Pendant enclosure, single non-illuminated push button, bottom mounted red LED indicating lamp.
9001AEQ3438	health bit (optional)	N.O.	High Visibility LED Indicator - Red	Pendant enclosure, single non-illuminated push button, bottom mounted high visibility red LED indicating lamp.

#### Dimensions SPX BWPEND5

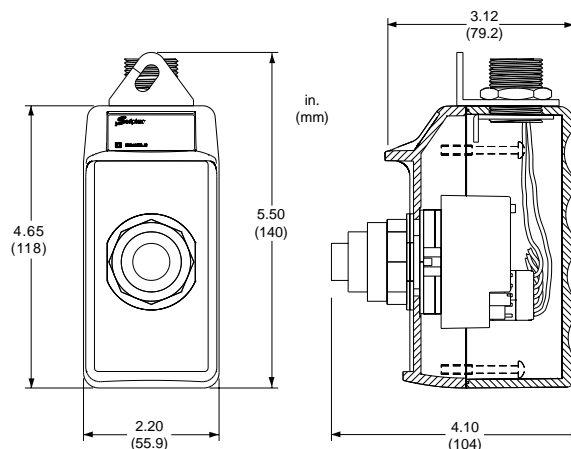

Pendant connector receptacle: Torque nut to 23 - 27 lb-in.  
 Pendant enclosure screws: Torque screws to 15 lb-in.  
 Operator ring nut: Torque 6 - 8 lb-ft.  
 Note: Gasket must be in place to maintain enclosure rating.

#### 9001AEQ3370

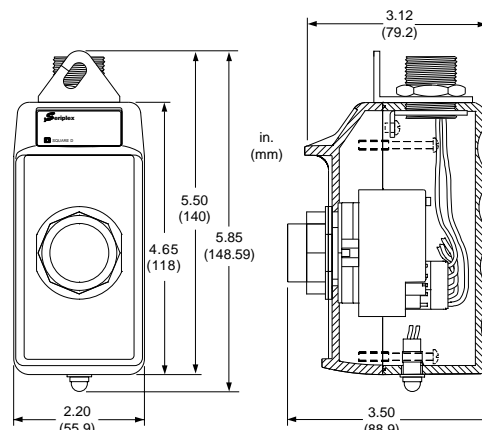

Pendant connector receptacle: Torque nut to 23 - 27 lb-in.  
 Pendant enclosure screws: Torque screws to 15 lb-in.  
 Operator ring nut: Torque 6 - 8 lb-ft.  
 Note: Gasket must be in place to maintain enclosure rating.

#### 9001AEQ3438

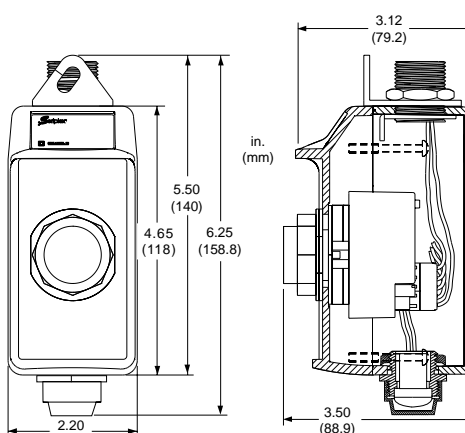

Pendant connector receptacle: Torque nut to 23 - 27 lb-in.  
 Pendant enclosure screws: Torque screws to 15 lb-in.  
 Operator ring nut: Torque 6 - 8 lb-ft.  
 Lens cap: Finger tighten  
 Note: Gasket must be in place to maintain enclosure rating.



# SERIPLEX® Intelligent Wiring System

## Product Information — I/O Modules and Embedded Products

### Receptacle Pin-out

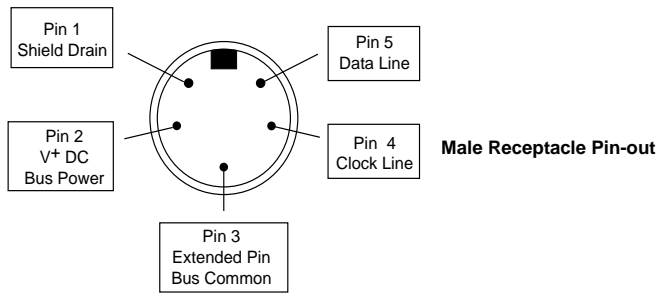

SPXSST2 Set-Up Tool . . . . . page 48  
 Mini-style Quick Change Sealed Connectors & T's . . . . . page 45  
 CPU Interface Cards . . . . . page 11  
 Power Supplies . . . . . page 6  
 System Overview . . . . .page 5 - 8

### Options, Replacement Parts and Accessories

Catalog Number	Description
9001A31	Push button lens - amber (for SPXBWPEND5)
9001B350	BW pendant hanger bracket
9001R31	Red, plastic, fresnel pilot light lens cap (for 9001AEQ3438)
SPXHH2P2CABLE	Hand-held set-up tool adaptor cable for 5-pin mini-style connectors
SPXLEDA1	LED lamp - amber (SPXBWPEND5 only)
SPXMQ5ADAPT	5-pin mini-style connector adaptor for the standard SPXHH2A2CABLE set-up tool cable.

### Control Bus Specifications

SERIPLEX bus power requirements nominal voltage rating power supply voltage range	24 Vdc 19.2 to 30 Vdc (including ripple)
Nominal bus power supply current drain at 25°C, 24 Vdc: SPXBWPEND5 9001AEQ3370 9001AEQ3438	20 mA 16 mA 26 mA
Maximum power supply current drain at 25°C, 24 Vdc: SPXBWPEND5 9001AEQ3370 9001AEQ3438	24 mA 20 mA 30 mA
Module capacitance	75 pF typical
Bus clock frequency operating range	10 to 192 kHz
Reverse polarity protection provided	Yes for + and - bus power leads

For additional information on these products, the following documents are available from the Internet at [www.squared.com](http://www.squared.com) or from Square D's DFAX fax on demand line 1-800-557-4556.

D-Fax#	Bulletin #	Description
1219	30298-052-01	SERIPLEX Material Pull Pendant Station - SPXBWPEND5
1248	30298-053-01	SERIPLEX Material Pull Pendant Station - 9001AEQ3370
2951	30298-068-01	SERIPLEX Material Pull Pendant Station - 9001AEQ3438

# SERIPLEX® Intelligent Wiring System

## Product Information — I/O Modules and Embedded Products

### XUJ PHOTOELECTRIC COMMUNICATION MODULE

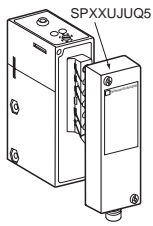

These modules provide monitoring and control of the Telemecanique XUJ line of photoelectric sensors. The through-beam emitter base draws power from the control bus, but does not require communication capabilities. Order the XUJ photoelectric sensors separately (see page 34).

#### Features

- Communication module mates with many of the XUJ line of photosensors. See page 34 for a complete listing of compatible sensors.
- Depending upon the XUJ sensor selected to mate with the SERIPLEX module, the following capabilities are monitored or controlled via the SERIPLEX control bus:
  - Absence or presence of the photosensor target.
  - Marginal signal detection of the photosensor, due to sensor misalignment, dirty lenses or dirty reflectors.
  - Light operation / dark operation selectable via the SERIPLEX control bus.
  - Confirmation of communication connection by use of a “health bit.”
  - Light / dark operation selection via the control bus also allows confirmation of proper sensor operation and alignment from the control room. Simply toggle the light / dark operation control and verify the appropriate control bus signal response.
- Micro-style quick connector allows for a reliable, quick and efficient control bus connection.

#### Product Selection

Catalog Number	Description
SPXXUJL9	SERIPLEX communication module for XUJ sensors, with 9' pigtail
SPXXUJUQ5	SERIPLEX communication module for XUJ sensors, with 5-pin micro-style connector

#### Assembly and Dimensions

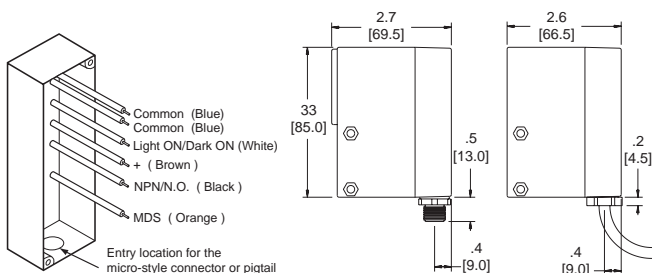

SPXSST2 Set-Up Tool	page 48
Cabling Components	page 39 - 45
CPU Interface Cards	page 11
Power Supplies	page 6
System Overview	page 5 - 8

### Options, Replacement Parts and Accessories

Catalog Number	Description
SPX22UM5L06	micro-style connector plug, 5-pin, male, 6" pigtail, 22AWG conductors (for use with XUJ through-beam emitters)
Call local sales office	Pre-assembly of the SERIPLEX communication base to an XUJ photosensor.

### Control Bus Specifications

SERIPLEX bus power requirements	
nominal voltage rating	24 Vdc
power supply voltage range	19.2 - 30 Vdc (including ripple)
Bus power supply current drain ■ (25°C, 24 Vdc).	17 mA typical
Bus power supply current drain ■ (-25°C, 30 Vdc)	21 mA typical
Module capacitance	
SPXXUJL9	417 pF (includes 9' pigtail)
SPXXUJUQ5	75 pF
Bus clock frequency operating range	10 - 192 kHz
Reverse polarity protection provided	Yes for + and - bus power leads

■ Excludes the XUJ sensor current draw. Add in the appropriate current draw value from the sensor specifications table from page 34.

### General Specifications

Temperature ratings	
Operating	-25° to +60°C (-13° to +140°F)
Addressing and set-up	0° to +60°C (+32° to +140°F)
Storage	-40° to +80°C (-40° to +176°F)
Relative humidity	5 to 95%, non-condensing
Micro-environmental category	II (per IEC664-1, Section 2.5.1)
Shock (IEC 68-2-27)	30 g, 3 axes, 11 ms duration, half-sine pulse
Vibration (IEC 68-2-6)	10 to 55 Hz, 1 mm peak-to-peak, 2 hours in 3 axes
Electrical noise immunity	
Electrostatic Discharge	IEC 61000-4-2 Level 4 (8kV contact, 15kV air discharge)
Electromagnetic Field	IEC 61000-4-3 Level 3 (10V/m)
Fast Transient Burst	IEC 61000-4-4 Level 3 (2kV input power, 1kV control bus)
Impulse	IEC 60947-5-2 Level 3 (2.5 kV)
Conducted RFI	IEC 61000-4-6 Level 3 (10Vrms)
Approvals	UL File E114926 CSA File LR53531 CE Mark
Cover screw torque requirements	0.45 - 0.68 N•m (4 - 6 lb-in)
Wiring terminal screw torque requirements:	
XUJL sensors	0.23 - 0.45 N•m (2 - 4 lb-in)
all other XUJ sensors	0.45 - 0.68 N•m (4 - 6 lb-in)

For SERIPLEX module only. For XUJ sensor specifications, consult the appropriate product instruction bulletin for details.

### Addressing and Functionality Designation

Address	Inputs (function)	Outputs (function)
A	Target detected. Photoelectric sensor output signal is placed on the control bus.	Not used.
B	Module diagnostics: Marginal detection signal (MDS) or Health bit	Light / dark operation selection via the SERIPLEX control bus.

► For an explanation of the health bit, reference SERIPLEX Design, Installation and Troubleshooting (bulletin #30298-035-01).



# SERIPLEX® Intelligent Wiring System

## Product Information — I/O Modules and Embedded Products

### Selecting XUJ Photoelectric Sensors

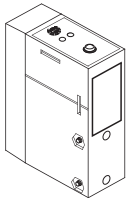

This information is provided for selecting an XUJ sensor for use with the communication module explained on pages 33- 34.

#### Features

- High performance housing is made of ULTEM™ synthetic resin.
- Sensor materials and design provide reduced condensation on the lenses due to heat/cold changes
- Sensor interior contains Finger Guard (isolated terminals in “ready to wire” position)
- Flat lenses (except for polarized versions) inhibit dust build-up
- Infrared modulated LED emission for a high ambient light immunity (note: visible red used for polarized models)
- Noise and transient protection
- Frontal LED output indicator aids with sensor set-up and alignment

### Product Selection

Output Type	XUJ			XUJL
	Relay	Solid State	Relay w/ Timing	Relay - Economy
<b>Sensing Mode</b>				
Emitter	XUJM1000	XUJM1000	XUJM1000	XUJLM1503
Through-Beam Receiver	XUJM100314	XUJK103534	XUJT100314	XUJLM1514
Retroreflective*	XUJM06031	XUJK0635	XUJT06031	XUJLM0811
Polarized Retroreflective*	XUJM060319	XUJK063539	XUJT060319	XUJLM0619
Proximity (Diffuse) - 27"	XUJM700318	XUJK703538	XUJT700318	n/a
Proximity (Diffuse) - 48"	XUJM120318	XUJK123538	XUJT120318	n/a

\* Reflectors must be ordered separately.

### Options, Replacement Parts and Accessories

Catalog Number	Description
XUCA41	Mounting bracket type for XUJ sensors, except for XUJL types (included with sensor)
XUZA49	Mounting bracket type for XUJL sensors (included with sensor)
XUJZ01	Optional adjustment cover (not needed for XUJL types)
RF30	3.25" diameter, acrylic lens
RF20	2.38" diameter, acrylic lens
RF10	1.31" diameter, acrylic lens
RF13	3.25" x 1.5" acrylic lens
XUZC100	4" x 4" acrylic lens
XUZC24 ●	1.3" x 1.1" close proximity acrylic lens
XUZC50 ●	2" x 2" close proximity acrylic lens

- These reflectors must always be mounted in the vertical plane with respect to the optical axis of the switch.

### Dimensions

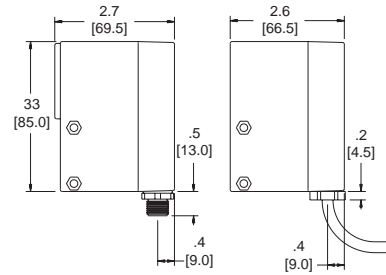

### General Specifications

	XUJ-M & XUJ-T Relay Output Standard & Timing Versions	XUJ-K Solid State Outputs	XUJ-L Relay Output Economy Version
Sensing ranges			
through-beam	41'	41'	61'
retroreflective (reflector required)	33'	33'	33'
polarized retroreflective (corner cube reflector required)	24'	24'	24'
proximity (diffuse) with background suppression - 27"	27"	27"	not available
proximity (diffuse) with background suppression - 48"	48"	48"	not available
Output Types	Relay	Solid State DC Complementary pnp/npn	Relay
No load power supply current (max)	30 mA	45 mA	30 mA
Operating frequency	20 Hz	200 Hz	20 Hz
On delay (max)	25 ms	2 ms	25 ms
Off delay (max)	25 ms	2 ms	25 ms
Power up delay (max)	60 ms	15 ms	60 ms
Marginal Detection Signal (MDS) output	no	yes	no
Output protection circuitry		reverse polarity protection short circuit protection (scp)	
Separate (independent) ON and OFF delay timer option (0.25 sec. to 15 sec.)	yes (XUJ-T models)	no	no
Light / Dark Operation Selectable	yes	yes	Light Operate only
Sensitivity Adjustment	yes	yes	no
Frontal LED output indicator	yes	yes	yes
2 LED alignment system with 360° visibility	yes	yes	no
Mounting bracket type (included with sensor)	XUCA41	XUCA41	XUZA49
Optional adjustment cover	XUJZ01	XUJZ01	not avail.

	XUJ	XUJL
Temperature range:		
operating	-25° to 60°C (-13° to 140°F)	-25° to 55°C (-13° to 131°F)
storage	-40° to 80°C (-40° to 176°F)	-40° to 70°C (-40° to 158°F)

Enclosure rating NEMA CENELEC (IEC)	1, 3, 6, 12, 13 IP67
Vibration resistance	7G, 1.5 mm amplitude, 10 Hz to 55 Hz
Shock resistance	30G for 11 ms
Electrostatic discharge (ESD)	IEC 61000-4-2 relay: Level 3 (8 kV) DC out: Level 2 (4 kV)
Radio frequency immunity (RFI)	IEC 61000-4-3 Level 3 (10 V/m)
Fast transients (motor start / motor stop interference)	IEC 61000-4-4 Level 3 (1 kV)
Impulse voltages (lightening, etc.)	IEC 947-5-2 Level 3 (2.5 kV)
Approvals	UL Listed, File E-164353 Guide NKCR2 CSA File LR44087 Class 3211 03 CE Mark



# SERIPLEX® Intelligent Wiring System

## Product Information — I/O Modules and Embedded Products

### IEC CONTACTOR ADAPTOR MODULE



The Contactor Adaptor Modules provides an interface between the SERIPLEX control bus and any of the Telemecanique D-Line contactors, Sizes D09 thru D80. Single-bit bus interface circuitry is used in this module. If multiplexed operation is used by the CPU interface card, the contactor adaptor module is scanned every frame. This adaptor module is

not capable of being multiplexed.

#### Features

- Easily snaps onto any Telemecanique D-Line contactor
- Provides control for D-Line contactor sizes D09 thru D80 (0.5 HP thru 60 HP)
- Switches coil voltages up to 300 Vac or 30 Vdc
- Uses quick and easy IDC panel connection cabling including preterminated cable (Catalog # CBL2222P38C05L20)
- LED indicators provide power-on status, holding circuit status and coil control output status
- Mechanical link converts contact carrier position into a control bus signal. Useful for holding circuit and other diagnostic functions (overload trip, welded contacts, etc.)
- Available input address for optional alarm signaling back to the host controller including loss of communication signal

#### Product Selection

Catalog Number	Input Type Holding Circuit Status Address A	Output Type Coil Control Address B
LA4SPX	N.O.	SPST electromechanical relay ♦

♦ Important: To ensure adequate relay output life, a flyback diode (Telemecanique part #LA4DC1U) must be used with DC coil control voltages.

#### Dimensions and Assembly

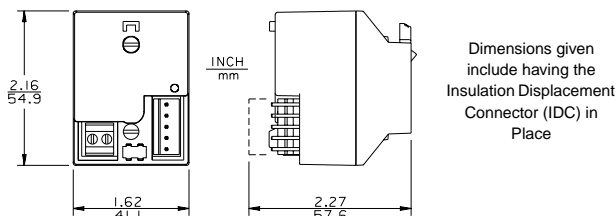

Attaching and removing an LA4SPX to an IEC D-Line Contactor

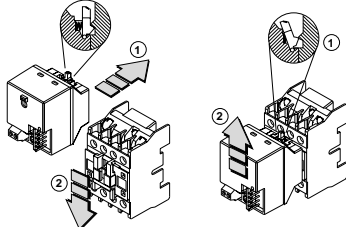

#### Options, Replacement Parts and Accessories

Catalog Number	Description
SPXUSER3	Replacement user label (has marking surface for addresses and control words). Quantity 10.
Add a 'T' to the end of a catalog number *	Conformal coating. Increases Micro-Environmental Category rating from MEC pollution degree II to MEC pollution degree III, as outlined in IEC 664-1, section 2.5.1. Conformal coating meets MIL-I-46058C.

\* Example: To order conformal coating for catalog number LA4SPX, change to LA4SPXT.

#### Specifications

SERIPLEX bus power requirements:	
Nominal voltage rating	24 Vdc
Power supply voltage range at 25°C	19.2 to 30 Vdc (including ripple)
Bus power supply current drain (25°C, 24 Vdc)	16 mA typical
Worst case bus power supply current drain (-25°C, 30 Vdc)	24mA
Module capacitance	75 pF typical
Bus clock frequency operating range	10 kHz to 200 kHz
Operating temperature	-25 to +70°C (-13 to +158°F)
Storage Temperature	-40 to +85°C (-40 to +185°F)
Relative Humidity	5 to 95%, non-condensing
Electromechanical Relay Rating (UL)	250 Vac, 30 Vdc, 2.5 A resistive pilot duty: AC - 180VA, DC - 15 VA, C300
Micro-environmental category	II (per IEC664-1, Section 2.5.1)
Shock	IEC D-Line: meets or exceeds IEC D-Line contactor ratings
Vibration	IEC D-Line: meets or exceeds IEC D-Line contactor ratings
Noise immunity:	
Electrostatic Discharge (ESD)	IEC801-2
Radio Frequency Immunity (RFI)	IEC801-3
Fast transients	IEC801-4
Impulse	IEC255-4
Approvals	UL File E114926, CSA File LR53531
Screw terminal block specifications	single conductor: UL 14 - 22 AWG, CSA 14 - 26 AWG
Conductor capacity	two conductors: 18 AWG - 28 AWG
Screw terminal torque	0.4 N•m (3.5 lb. inches)
Fracture torque ♦	0.8 N•m (7.0 lb. inches)
Wire strip length	7 mm (0.3 inches)

▼ See page 15-16 for additional output relay specifications.

♦ The fracture torque leads to damage of the screw shaft, stripping of the thread or deformation of the screw slot.

#### Wiring and LED Indicators

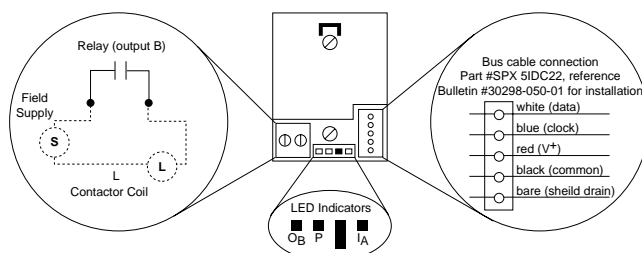

LED	Color	Function and Address
I <sub>A</sub>	yellow	Input A Active
P	green	Bus Power Applied
O <sub>B</sub>	yellow	Output B Active

SPXSST2 Set-Up Tool	page 48
Cabling Components	page 39 - 45
CPU Interface Cards	page 11
Power Supplies	page 6
System Overview	page 5 - 8



# SERIPLEX® Intelligent Wiring System

## Product Information — I/O Modules and Embedded Products

### NEMA STYLE CONTACTOR ADAPTOR MODULE

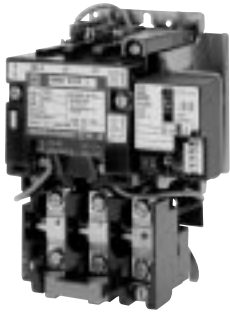

The Contactor Adaptor Module provides an interface between the SERIPLEX control bus and any of the Square D Company line of Type S contactors and starters NEMA sizes 00-4. Single-bit bus interface circuitry is used in this module. If multiplexed operation is used by the CPU interface card, the contactor adaptor module is scanned every frame. This adaptor module is not capable of being multiplexed.

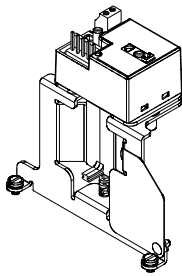

#### Features

- Provides control for Type S NEMA sizes 00-4 contactors and starters.
- Switches coil voltages up to 300 Vac or 30 Vdc.
- Uses quick and easy IDC panel connection cabling including preterminated cable (catalog #CBL2222P38C05L20).
- LED indicators provide power-on status, holding circuit status and coil control output status.
- Mechanical link converts contact carrier position into a control bus signal. Useful for holding circuit and other diagnostic functions (example: overload trip, welded contacts)
- Available input address for optional alarm signaling back to the host controller including loss of communication signal.

### Assembly and Dimensions

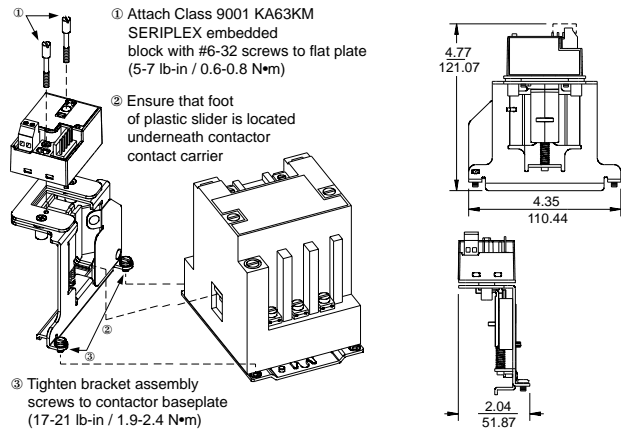

SPXSST2 Set-Up Tool ..... page 48  
 Cabling Components.....page 39 - 45  
 CPU Interface Cards ..... page 11  
 Power Supplies ..... page 6  
 System Overview ..... page 5 - 8

### Options, Replacement Parts and Accessories

Catalog Number	Description
9998SK04	Bracket only, which is used with the 9999SK04 assembly
9001KA63KM	SERIPLEX module only. When combined with the 9998SK04 bracket, this forms the completed assembly part #9999SK04.
SPXUSER2	Replacement user label (has marking surface for addresses and control words). Quantity 10.
Add a 'T' to the end of the catalog number	Conformal coating. Increases Micro-Environmental Category rating from MEC pollution degree 2 to MEC pollution degree 3 (per IEC664-1, section 2.5.1). Also meets MIL-I-46058C.

### Product Selection

Catalog Number	Input Type Holding Circuit Status Address A	Output Type Coil Control Address B
9999SK04	N.O. ¥	SPST electromechanical relay

¥ The normally closed signal of the 9001KA63KM module, which is provided with the 9999SK04, is mechanically-held open by the contactor. A logic 1 signal is communicated for Input Address A when the contact carrier is pulled in.

**NOTE: Do not use the 9001KA62KM module with the 9998SK04 NEMA bracket assembly.**



# SERIPLEX® Intelligent Wiring System

## Product Information — I/O Modules and Embedded Products

### Specifications

SERIPLEX bus power requirements: Nominal voltage rating Power supply voltage range at 25°C	24 Vdc 19.2 to 30 Vdc including ripple
Bus power supply current drain (25°C, 24 Vdc)	no relay output: 7 mA typical relay output: 16 mA typical bus powered LED lamp: 18 mA typical
Worst case bus power supply current drain (-25°C, 30 Vdc)	no relay output: 8 mA relay output: 24 mA bus powered LED lamp: 24 mA
Module capacitance	75 pF typical
Bus clock frequency operating range	10 kHz to 200 kHz
Operating temperature	-25 to +70°C (-13 to +158°F)
Storage Temperature	-40 to +85°C (-40 to +185°F)
Relative Humidity	5 to 95%, non-condensing
Electromechanical Relay Rating (UL)	250 Vac, 30 Vdc, 2.5 A resistive pilot duty: AC - 180VA, DC - 15 VA, C300
Micro-environmental category	II (per IEC664-1, Section 2.5.1)
Shock (IEC 68-2-27) ♦	30g, 3 axes, 11 ms duration, half sine pulse
Vibration (IEC 68-2-6) ♦	10 to 55 Hz, 1 mm peak-to-peak, 2 hour in 3 axes
Noise immunity: Electrostatic Discharge (ESD) Radio Frequency Immunity (RFI) Fast transients Impulse	IEC801-2 IEC801-3 IEC801-4 IEC255-4
Compliance standards	UL File E114926, CSA File LR53531
Screw terminal block specifications (relay versions only) conductor capacity	single conductor: UL 14 - 22 AWG, CSA 14 - 26 AWG two conductors: 18 AWG - 28 AWG
Screw terminal torque Fracture torque ♦ Wire strip length	0.4 N•m (3.5 lb. inches) 0.8 N•m (7.0 lb. inches) 7 mm (0.3 inches)
Maximum allowable standard contact blocks mounted on a SERIPLEX dedicated module	One Contact Block (Class 9001 Type KA1 through Class 9001 Type KA6)

♦ Meets or exceeds ratings for Class 9999 Type SA - SJ auxiliary contacts.

### Wiring and LED Indicators

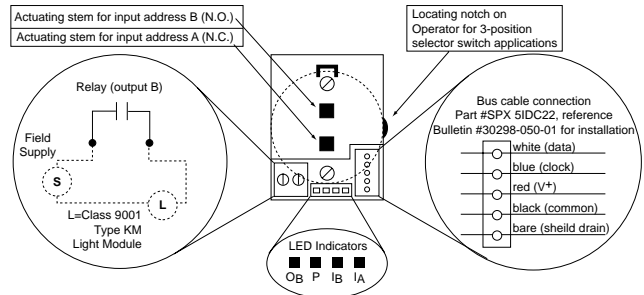

For additional information on this product, request bulletin #30298-056-01, available from the Internet at [www.squared.com](http://www.squared.com) or from Square D's DFAX line, document #1414.

Interpret the SERIPLEX cable catalog numbers as follows on next the next page.

Square D offers enclosed combination starters in both NEMA and IEC styles.

Merging the benefits of SERIPLEX device connectivity with the industry leading combination starter offers users:

- SERIPLEX I/O modules which are prewired to starters and/or disconnects allowing quick installation.
- Ability to have virtually any style combination starter delivered "network ready."
- Eliminates additional user control wiring for auxiliary contacts.



# SERIPLEX® Intelligent Wiring System

## Product Information — Cabling Components

### BUILDING A CABLE CATALOG NUMBER

Catalog #

	<b>CBL</b>	<b>●●</b>	<b>●●</b>	<b>●●</b>	<b>P●●</b>	<b>α●●</b>	<b>α</b>	<b>●●●</b>
<b>Cable Prefix</b> _____	_____	_____	_____	_____	_____	_____	_____	_____
CBL = cable (CL2 rated) CBLFEP = teflon coated cable (CL2P rated)								
<b>Gauge Size – Bus Power Conductors</b> _____		_____	_____	_____				
16 = 16 AWG (standard) 18 = 18 AWG 22 = 22AWG (panel cable)								
<b>Gauge Size – Clock and Data Conductors</b> _____			_____	_____				
22 = 22 AWG (standard)								
<b>Gauge Size – Auxiliary Power Conductors</b> _____				_____				
blank = no auxiliary power conductors 12 = 12 AWG 14 = 14 AWG 16 = 16 AWG								
<b>Cable Capacitance (in picofarads per foot)</b> _____						_____		
<b>Special Cable Type</b> _____							_____	
DB = direct burial type cable BS = braided shield type cable C●● = daisy chain cable with connector spacings of ●● inches M = mini style connector attached X = special cable length (followed by ## feet on spool)								
<b>Connector Placement or Type</b> _____							_____	
Q = sealed quick connector on both ends L = IDC connectors for daisy chain cable (connector spacing and cable length in inches)								
<b>Cable Lengths for Cable with Connectors</b> _____								_____
●●● = Cable length in feet up to 999 feet. For 1,000 feet or more, use K to designate 1,000 (eg; 2K = 2,000 feet)								

# SERIPLEX® Intelligent Wiring System

## Product Information — Cabling Components

### CABLING COMPONENTS

#### Standard cable (Stock and Non-stock)

##### Stocked Cable

Available in 500' length spools as standard. The special length of 5,000' is available also. Add **X5K** to the cable part number. Call your local sales office for pricing and delivery.

Cable Part Number	Cable Specifications							
	O.D. (nominal)	Shield Drain Wire	Wire Size Bus Supply	Wire Size Signal	Wire Size Auxiliary Supply	Capacitance Rating - 2nd Pair	Rated	Special Cable Features
CBL1622P16	0.360"	foil w/ 22 AWG	16 AWG	22 AWG	—	16 pF / foot	CL2	Standard cable
CBL1622P16DB	0.360"	foil w/ 22 AWG	16 AWG	22 AWG	—	call		Direct burial jacket
CBL162212P16	0.472" x 0.351"	foil w/ 22 AWG	16 AWG	22 AWG	12 AWG	16 pF / foot	CL2	Auxiliary supply conductors (12 AWG)
CBL162216P16	0.443" x 0.351"	foil w/ 22 AWG	16 AWG	22 AWG	16 AWG	16 pF / foot	CL2	Auxiliary supply conductors (16 AWG)
CBL1822P20	0.300"	foil w/ 22 AWG	18 AWG	22AWG	—	20 pF / foot	CL2	Low cost cable

1 unit = 500' spool

##### Non-stock Cable

Available as a factory order in 5,000 foot spools only.

Cable Part Number	Cable Specifications							
	O.D. (nominal)	Shield Drain Wire	Wire Size Bus Supply	Wire Size Signal	Wire Size Auxiliary Supply	Capacitance Rating - 2nd Pair	Rated	Special Cable Features
CBL1622P16BSX5K	0.375"	foil and braid	16 AWG	22 AWG	n/a	16 pF / foot	CL2	Braided shield
CBL162214P16X5K	0.454" x 0.351"	foil w/ 22 AWG	16 AWG	22 AWG	14 AWG	16 pF / foot	CL2	Auxiliary supply conductors (14 AWG)
CBLFEP1622P16X5K	0.310"	foil w/ 22 AWG	16 AWG	22 AWG	—	16 pF / foot	CL2P	Teflon coated
CBLFEP162212P16X5K	0.420" x 0.310"	foil w/ 22 AWG	16 AWG	22 AWG	12 AWG	16 pF / foot	CL2P	Teflon coated plus auxiliary supply conductors (12 AWG)

1 unit = 5,000' spool

##### Panel Cabling (Stocked Cable)

Available in 100' length spools as standard. Used for interconnect of embedded SERIPLEX product.

For preterminated cable, panel cabling tools and accessories see pages 39 - 47.

Cable Part Number	Cable Specifications							
	O.D. (nominal)	Shield Drain Wire	Wire Size Bus Supply	Wire Size Signal	Wire Size Auxiliary Supply	Capacitance Rating - 2nd Pair	Rated	Special Cable Features
CBL2222P38	0.220"	foil w/ 22 AWG tin plated copper	22 AWG	22 AWG	—	38pF/foot	CL2	For panel cabling of SERIPLEX embedded modules

1 unit = 100' spool



# SERIPLEX® Intelligent Wiring System

## Product Information — Cabling Components

### QUICK-CHANGE MINI-STYLE CONNECTORS

Cable with sealed connectors use standard SERIPLEX cable. For 5-pin mini-connectors, CBL1622P16 cable is used. For 7-pin, mini-connectors, CBL162216P16 cable is used.



The sealed connectors conform to the following standards and specifications:

- ANSI/B93.55M-1981: Mini standard
- 1995 SAE Standard: Specification for Mini, Micro, and Nano Change Plugs and Receptacles for Input Devices

Catalog Number	Description	Cable Length (A)
CBL1622P16MQ6	5-pin mini-connectors, one male & one female	6 ft. cable
CBL1622P16MQ10	5-pin mini-connectors, one male & one female	10 ft. cable
CBL1622P16MQ20	5-pin mini-connectors, one male & one female	20 ft. cable
CBL1622P16MQ50	5-pin mini-connectors, one male & one female	50 ft. cable
CBL1622P16MQ100	5-pin mini-connectors, one male & one female	100 ft. cable
CBL162216P16MQ6	7-pin mini-connectors, one male & one female	6 ft. cable
CBL162216P16MQ10	7-pin mini-connectors, one male & one female	10 ft. cable
CBL162216P16MQ20	7-pin mini-connectors, one male & one female	20 ft. cable
CBL162216P16MQ50	7-pin mini-connectors, one male & one female	50 ft. cable
CBL162216P16MQ100	7-pin mini-connectors, one male & one female	100 ft. cable

Cable in custom lengths are available as a factory order. A minimum order quantity for a special length is 10 pieces. All custom cable lengths must be in increments of one foot.

Example: 1 foot, 14 feet, 79 feet -- okay  
32.3 feet, 67 ft. 2 inches -- not okay

For 5-conductor cable assemblies: CBL1622P16MQ###  
Enter # as number of feet of cable in one foot increments.

Maximum length 100 ft. For other lengths contact factory.

### Physical Properties

Coupling nut material	Anodized machined aluminum or die cast Zamak #5 with bright zinc plate and clear chromate sealer
Contact material	Copper alloy
Contact plating	30 micro-inch gold over 50 micro-inch nickel
Molded head material	PVC (orange)
Insert material	PVC (orange)
Vibration	2,000,000 cycles per SAE #H1738-2
Cable strain relief	30 lbs. minimum per UL 817

### Electrical Properties

Voltage rating	300 volts
Current rating	3 amps
Contact resistance	<5 milli-ohms
Isolation resistance	>100 meg-ohms
Dielectric withstand	1,600 volts rms between adjacent terminals & terminals to shell per UL 498
Capacitance	16pF / ft. for cable, 15pF/T (typical between two adjacent contacts)
Compliance Standards	UL File E185342, cUL

### Environmental Properties

Temperature rating	-20°C to +60°C
Protection	IP -68, NEMA 6P

### Dimensions

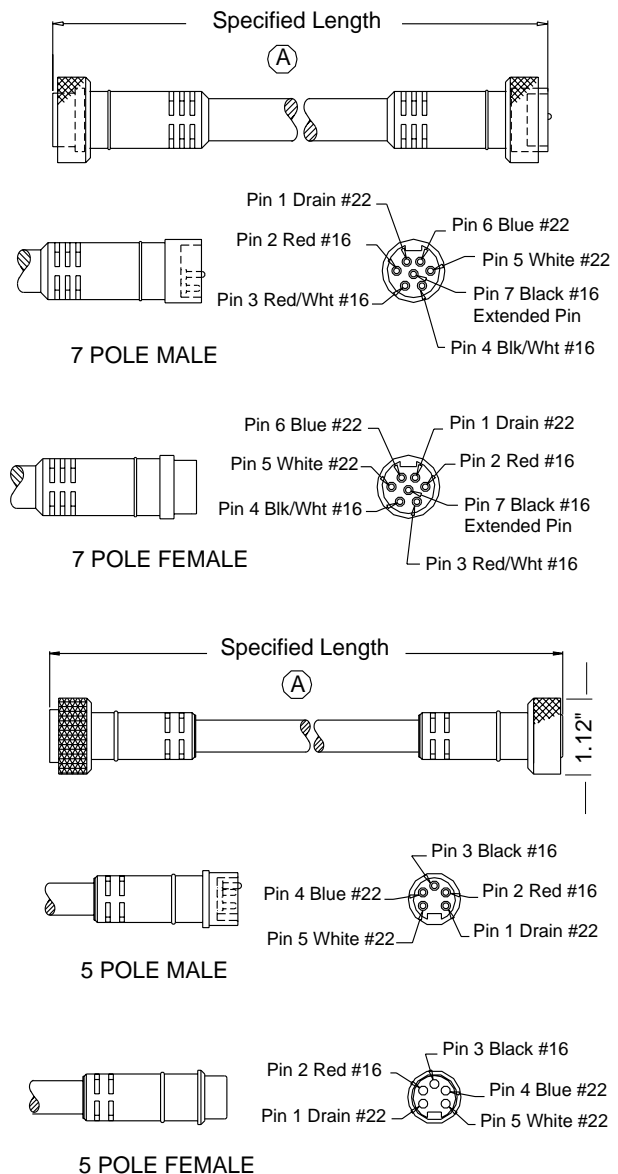

# SERIPLEX® Intelligent Wiring System

## Product Information — Cabling Components

### QUICK-CHANGE MICRO-STYLE CONNECTOR STANDARD AND ADAPTOR CABLE ASSEMBLIES

These cable assemblies use factory sealed connectors with SERIPLEX panel cable (panel cable is part #CBL2222P38). Typical applications include use with embedded products such as the SPXXUJUQ5 communication module for Telemecanique XUJ photoelectric sensors. Each cable assembly contains a plug (male) and a receptacle (female) sealed connector.

#### Features of the Micro-style Connectors

- Epoxy-coated coupler provides exceptional corrosion resistance. Passes 500-hour salt spray test per MIL standard 202F.
- Heavy duty polyurethane contact insert provides superior strength.
- Vibration resistant ratchet coupler prevents loosening in severe, high-vibration applications.
- Superior side load strength in excess of 100 lbs. Surpasses present industry standards by five times.
- Indicating arrow molded into connector for easy identification and keyway alignment.
- Adaptor cable assemblies using mini-style connectors allow termination of SERIPLEX embedded modules (such as the SPXXUJUQ5) to control bus junction points (such as the SPXTMQ5 and SPXTMQ7 connector "T's").

Catalog Number	Plug (male) Cable End Style	Receptacle (female) Cable End Style	Cable Length
CBL2222P38UQ3	5-pin micro	5-pin micro	3 feet
CBL2222P38UQ6	5-pin micro	5-pin micro	6 feet
CBL2222P38UQ9	5-pin micro	5-pin micro	9 feet
CBL2222P38XX3	7-pin mini	5-pin micro	3 feet
CBL2222P38XX6	7-pin mini	5-pin micro	6 feet
CBL2222P38XX9	7-pin mini	5-pin micro	9 feet
CBL2222P38XQ3	5-pin mini	5-pin micro	3 feet
CBL2222P38XQ6	5-pin mini	5-pin micro	6 feet
CBL2222P38XQ9	5-pin mini	5-pin micro	9 feet

For physical, electrical and environmental properties see page 40.

#### Dimensions

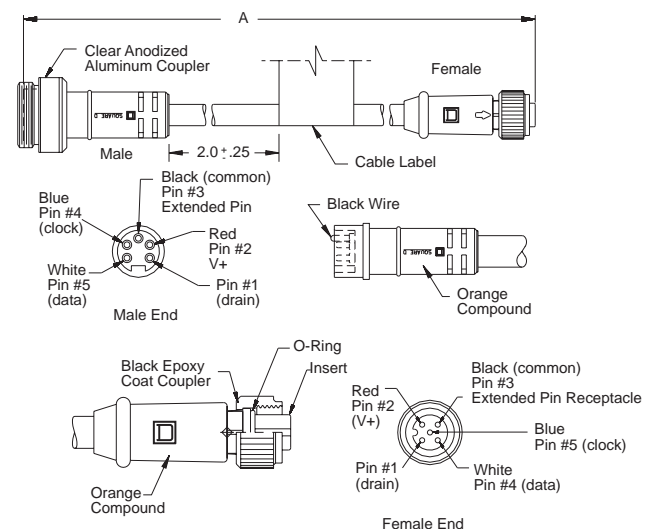
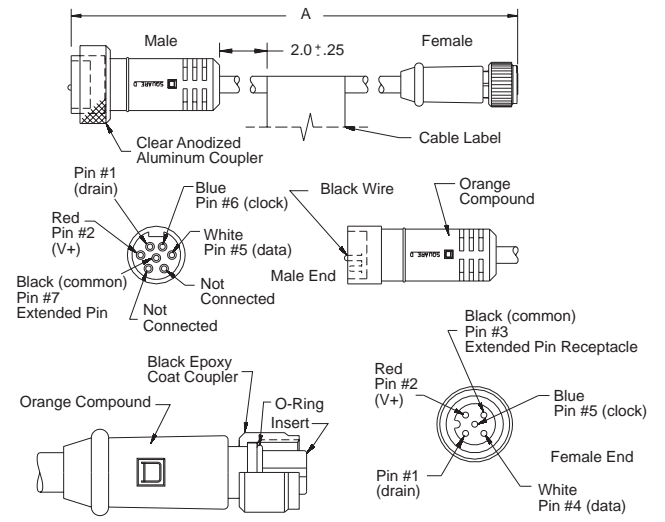
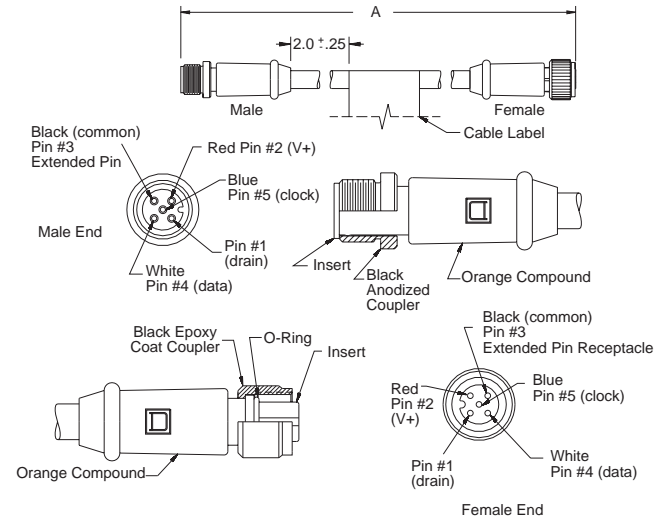

# SERIPLEX® Intelligent Wiring System

## Product Information — Cabling Components

### QUICK-CHANGE MICRO-STYLE CONNECTOR CABLE SPLITTERS

These cable assemblies use factory sealed connectors with SERIPLEX panel cable (panel cable is part #CBL2222P38). Typical applications include use with embedded products such as the SPXXUJUQ5 communication module for Telemecanique XJJ photoelectric sensors.

#### Features

- All connectors on this assembly are micro-style types.
- Epoxy-coated coupler provides exceptional corrosion resistance. Passes 500-hour salt spray test per MIL standard 202F.
- Heavy duty polyurethane contact insert provides superior strength.
- Vibration resistant ratchet coupler prevents loosening in severe, high-vibration applications.
- Superior side load strength in excess of 100 lbs. Surpasses present industry standards by five times.
- Indicating arrow molded into connector for easy identification and keyway alignment.

Catalog Number	Plug (male) Cable End Style	Receptacle (female) Cable End Style (2 per assembly)	Cable Length
CBL2222P38UY3	5-pin micro	5-pin micro	3 feet
CBL2222P38UY6	5-pin micro	5-pin micro	6 feet
CBL2222P38UY9	5-pin micro	5-pin micro	9 feet

For physical, electrical and environmental properties see page 40.

#### Dimensions

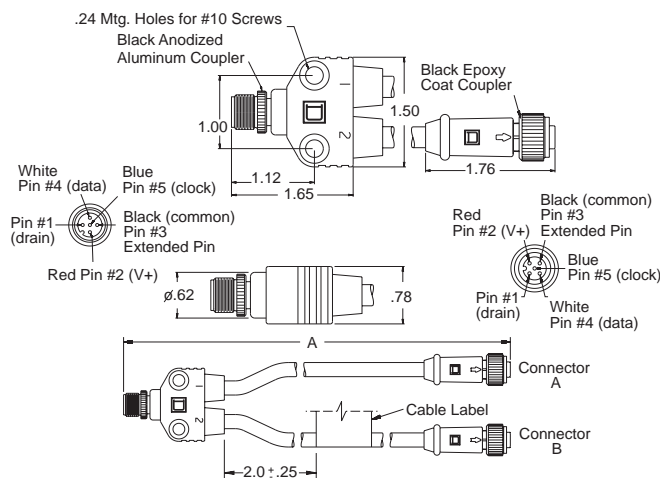

### QUICK-CHANGE MINI-STYLE T'S

The sealed connectors conform to the following standards and specifications:

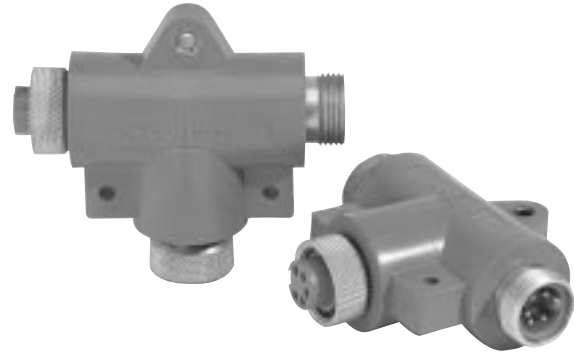

- ANSI/B93.55M-1981: Mini standard
- 1995 SAE Standard: Specification for Mini, Micro, and Nano Change Plugs and Receptacles for Input Devices

#### Mini-style T's

Catalog Number	Description
SPXTMQ5	mini-connector "T", 5-pin
SPXTMQ7	mini-connector "T", 7-pin
SPXTMR7	mini-connector "T", 7-pin trunk with a 5-pin drop

For specifications see page 40.



# SERIPLEX® Intelligent Wiring System

## Product Information — Cabling Components

### Dimensions

#### 5-Pole

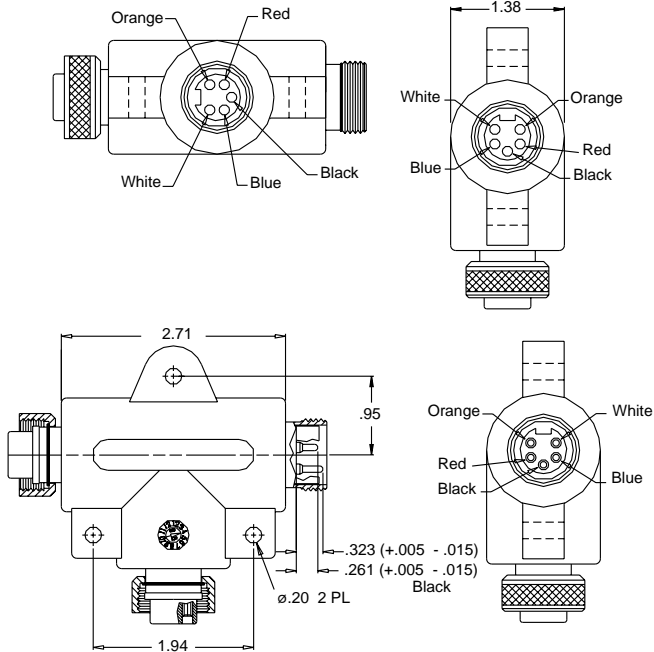

#### 7-Pole

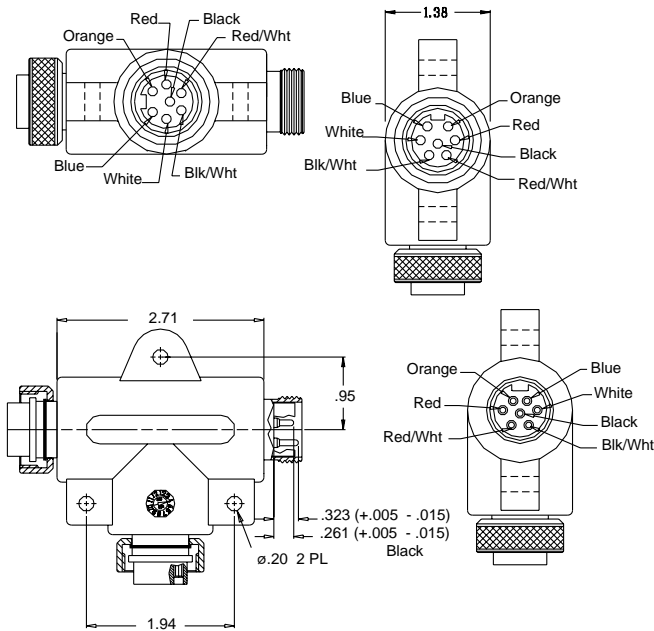

Catalog Number	Description
SPX22MMIDCL5	5-pole, mini-style plug (male), 5" pigtail with an IDC termination

### PLUGS AND RECEPTACLES

The SERIPLEX offering of plugs and receptacles allow ease of quick connection to panels, enclosures and other embedded I/O products. A variety of wire gauge sizes and pigtail lengths are offered to meet a variety of product applications.

Catalog Number	Connector Style	Number of Pins	Plug or Receptacle	Pigtail Length	Pigtail Wire Gauge
SPX16MF5L36	mini-style	5	receptacle (female)	36"	16 AWG
SPX16MM5L36	mini-style	5	plug (male)	36"	16 AWG
SPX22MF5L06	mini-style	5	receptacle (female)	6"	22 AWG
SPX22MM5L06	mini-style	5	plug (male)	6"	22 AWG
SPX18UF5L36	micro-style	5	receptacle (female)	36"	18 AWG
SPX18UM5L36	micro-style	5	plug (male)	36"	18 AWG
SPX22UF5L06	micro-style	5	receptacle (female)	6"	22 AWG
SPX22UM5L06	micro-style	5	plug (male)	6"	22 AWG
SPX16MF7L36	mini-style	7	receptacle (female)	36"	16 AWG
SPX16MM7L36	mini-style	7	plug (male)	36"	16 AWG
SPX22MF7L06	mini-style	7	receptacle (female)	6"	22 AWG
SPX22MM7L06	mini-style	7	plug (male)	6"	22 AWG

For physical, electrical and environmental properties see page 40.

### Dimensions for Plugs and Receptacles

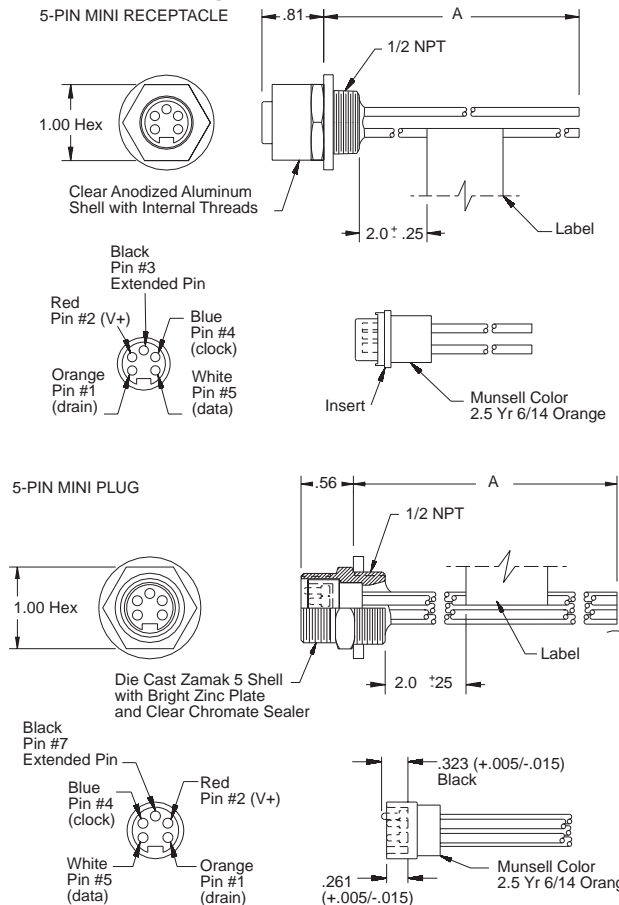

# SERIPLEX® Intelligent Wiring System

## Product Information — Cabling Components

### Dimensions for Plugs and Receptacles (continued)

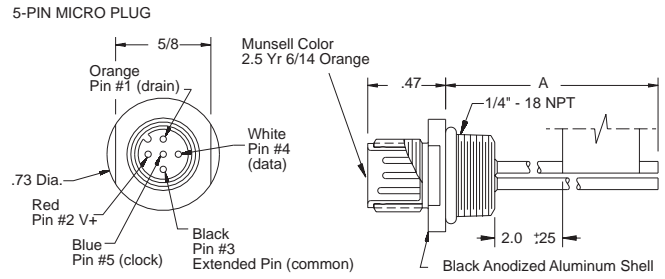
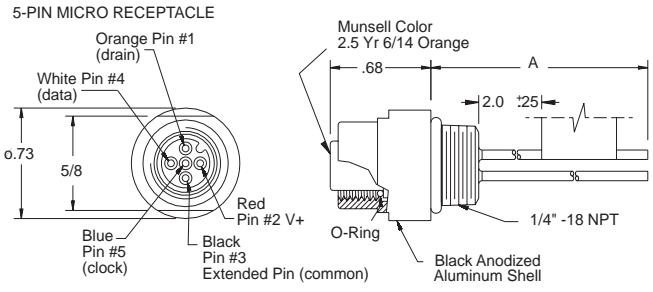
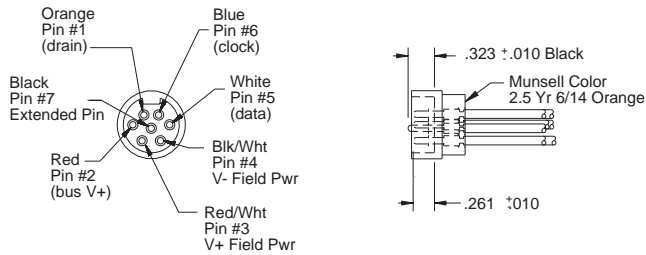
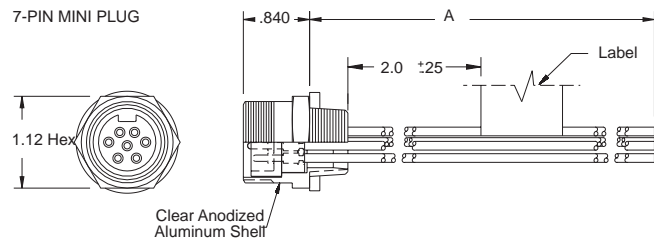
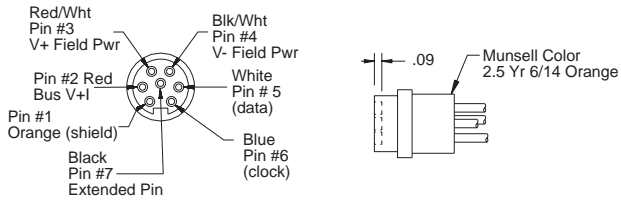
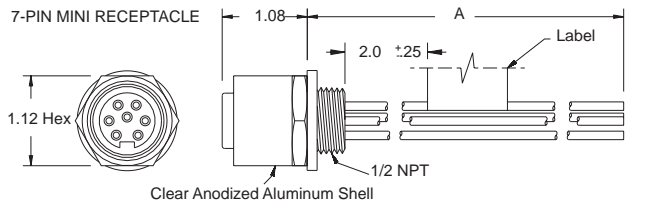

# SERIPLEX® Intelligent Wiring System Product Information — Cabling Components

## TJUNCT MODULE

The SPX-TJUNCT is a 3-way junction module for the SERIPLEX control bus. The module provides a convenient way of tying together cable drops and branches in a bus layout. The modules also provide a handy point for unplugging and isolating a section of the control bus when troubleshooting an installation.

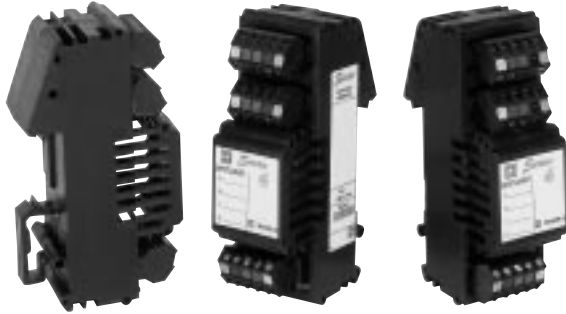

Catalog Number	Description
SPXTJUNCTV2	SERIPLEX 'T' junction module

## Specifications

Operating temperature	-25 to +70 °C (-13 to +158 °F)
Storage temperature	-40 to +85 °C (-40 to +185 °F)
Relative humidity	5 to 95%, noncondensing
Micro-environmental category	II (per IEC664-1, Section 2.5.1)
Shock (IEC 68-2-27)	30 g, 3 axis, 11 ms duration, half sine pulse
Vibration (IEC 68-2-6)	10 to 55 Hz, 1 mm peak-to-peak, 1/2 hour in 3 axis
I/O module capacitance	5 pF
Approvals	UL File Number E114926 CSA File Number LR53531 NOM-117
Screw terminal conductor capacity	Single conductor: 12 AWG - 28 AWG Two conductors: 16 AWG - 28 AWG
Screw terminal torque	0.5 - 0.8 N•m (4.4 - 7.0 lb-in)
Fracture torque▲	1.1 N•m (9.6 lb-in)
Wire strip length	11 mm (0.43 in)

▲ The fracture torque leads to damage of the screw shaft, stripping of the thread or deformation of the screw slot.

## Dimensions

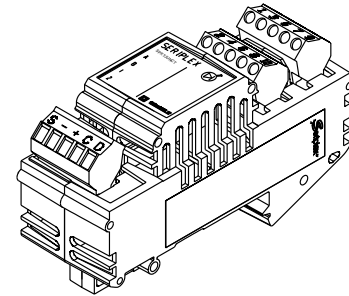
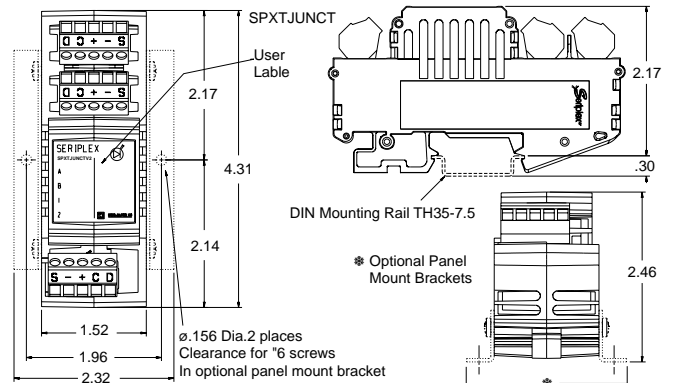

## Options, Replacement Parts and Accessories

Catalog Number	Description
SPXPANEL	Optional mounting legs for panel-mounting discrete I/O modules
SPXTERMBUS	Replacement terminal block – 5 terminals – bus connector markings
Add a 'T' to the end of a catalog number *	Conformal coating. Increases Micro-Environmental Category rating from MEC pollution degree II to MEC pollution degree III, as outlined in IEC 664-1, section 2.5.1. Conformal coating meets MIL-I-46058C.

\* Example: To order conformal coating for catalog # SPXTJUNCTV2, change to SPXTJUNCTV2T.

## Wiring Connections

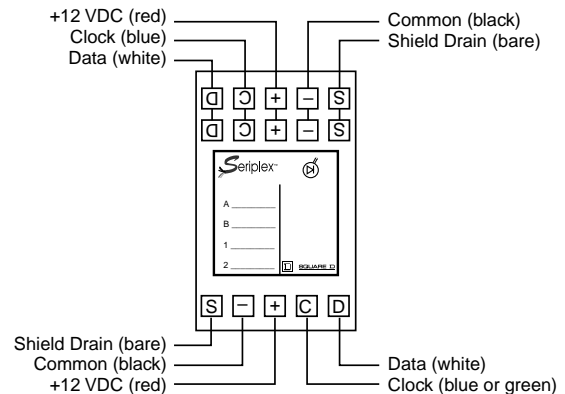

**NOTE:** Be sure and verify that no stray wiring strands have created a short between connector terminals.



# SERIPLEX® Intelligent Wiring System

## Product Information — Cabling Components

### DEDICATED MODULE PANEL CABLING PRODUCTS

#### Panel Cabling for Dedicated Modules

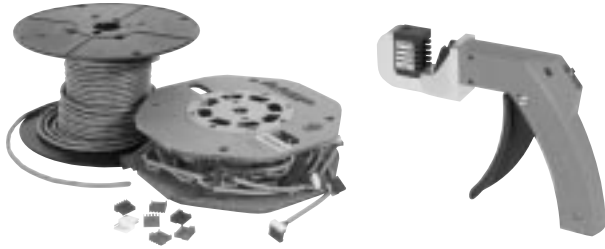

Two methods are available for interconnecting SERIPLEX dedicated module products:

- use the preterminated cable (part #CBL 2222P38C05L20)
- perform custom terminations with insulation displacement connector (IDC)

The SPX5IDC22 insulation displacement connector is a gold plated (30 micro-inch) IDC providing low connection impedance, high corrosion resistance and superior wear resistance. Do not use any substitutes.

The SPX5IDC22HT hand tool is designed with tolerances providing a highly reliable and repeatable connector termination.

Catalog Number	Description
CBL2222P38	SERIPLEX Control Bus Cable, four 22 AWG conductors plus 22 AWG shield drain, 38 pF/ft. capacitance, rated CL2 100' spool
CBL2222P38C05L20	Preterminated Cable, 5" IDC spacing, 20' length, 48 IDC's total
SPX5IDC22	Insulation Displacement Connector (IDC) and End Caps, 5 conductor, 22 AWG, Qty of 10
SPX5IDC22HT	IDC Termination Hand Tool, 5 conductor, 22 AWG IDC's
SPX5IDCS	IDC Splice
SPX5IDC22CAP	Spare IDC End Caps, Qty. of 10 to a package

#### Preterminated Cable

Catalog number CBL2222P38C05L20 is preterminated cable for panel installations using dedicated SERIPLEX product. The preterminated cable is provided in 20 foot lengths wrapped on a spool. The insulation displacement connectors (IDC's) are spaced 5" apart. Each spool contains a total of 48 connections.

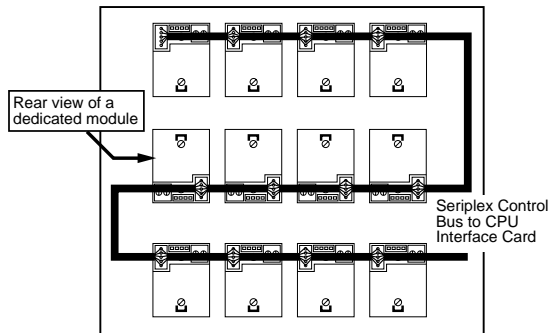

The SERIPLEX 30mm dedicated module may be mounted in any orientation. For daisy chaining purposes using the CBL2222P38C05L20 preterminated cable, installation works best when module orientation is alternated on each row as shown above.

Two cable sections can be spliced together using the SPX5IDCS splice for IDC's.

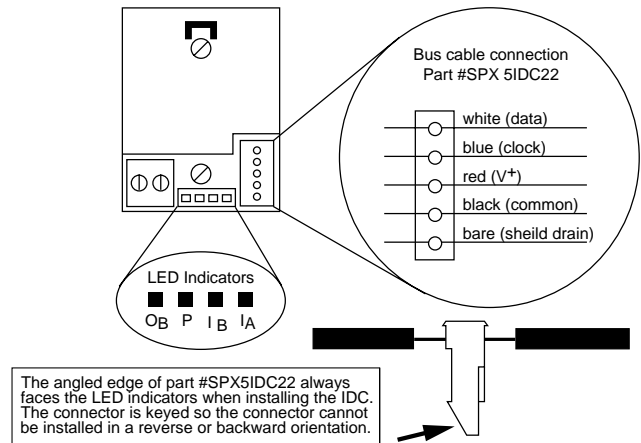

#### Custom Terminations using IDC's

For custom terminations using IDC's, use the following material:

- CBL2222P38 – SERIPLEX control bus cable
- SPX5IDC22 – IDC's
- SPX5IDC22HT – IDC Termination Hand Tool
- Bulletin #30298-051-01 – AMP Instruction Sheet for the IDC Termination Hand Tool (copy provided with each hand tool)
- SPXIDCS (optional) for splicing two cable sections together
- A coaxial cable stripper (optional)

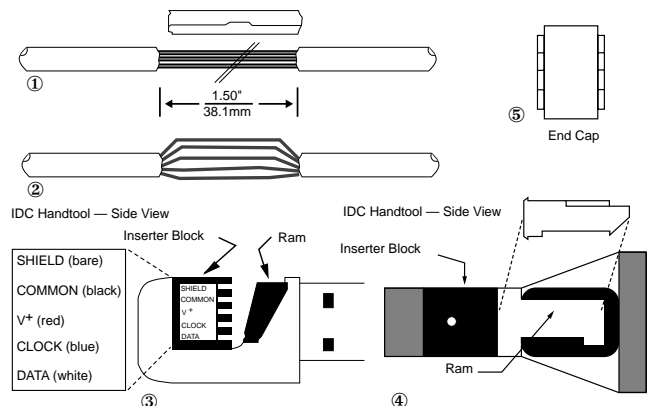

1. Remove jacket and foil. Use coaxial cable stripper for best results. A coaxial cable stripper from Ideal, Part #45-165 is recommended.
2. Fan the wires to aid in positioning
3. Slide the conductors into the appropriate slot of the inserter block.
4. Place the IDC into the ram as shown. Squeeze the IDC hand tool handle fully, then release. Remove the assembly and inspect the connection.
5. Add the IDC end cap, to ensure proper strain relief.

# SERIPLEX® Intelligent Wiring System Product Information — Cabling Components

## FERRULES AND RELATED TOOLS

### Mark and terminate wire simultaneously

Cable ends simultaneously provide a durable wire termination and a fast marking system. Simply strip the wire, insert it into the cable end and crimp it.



DZ5CA015UL



DZ5CE0253UL

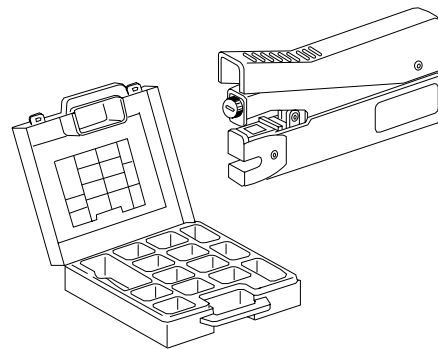

AT1 HB2

AT1 PA7

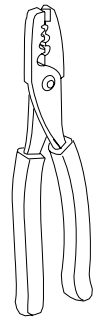

AT1 PA2

### Cable Ends without Marking Flag

Catalog Number	Dia. in mm <sup>2</sup>	AWG	Sleeve color	"A" (mm)	"B" (mm)	"C" (mm)	Std. Pack▲
DZ5CE005UL	0.50	22	White	13.0	3.0	1.4	1000
DZ5CE007UL	0.75	20	Blue	13.5	3.3	1.8	1000
DZ5CE010UL	1.00	18	Red	13.5	13.5	1.8	1000
DZ5CE015UL	1.50	16	Black	13.5	4.0	2.0	1000
DZ5CE0153UL	1.50	16	Black	22.8	4.0	2.0	1000
DZ5CE020	2.00	14	Yellow	14.5	4.4	2.3	1000
DZ5CE025UL	2.50	14	Gray	14.5	4.7	2.5	1000
DZ5CE0253UL	2.50	14	Gray	24.0	4.7	2.5	1000

### Ferrules for Two Conductors

Catalog Number	Dia. in mm <sup>2</sup>	AWG	Sleeve color	Std. Pack
AZ5DE005	0.50	22	White	500
AZ5DE007	0.75	20	Blue	500
AZ5DE010	1	18	Red	500
AZ5DE015	1.5	16	Black	500
AZ5DE025	2.5	14	Grey	250

### Cable Ends with Marking Flag Standard▲

Catalog Number	Dia. in mm <sup>2</sup>	AWG	Sleeve color	"A" (mm)	"B" (mm)	"C" (mm)	Std. Pack▲
DZ5CA007UL	0.75	20	Blue	13.5	3.3	1.8	1000
DZ5CA010UL	1.00	18	Red	13.5	3.5	1.8	1000
DZ5CA015UL	1.50	16	Black	13.5	4.0	2.0	1000
DZ5CA025UL	2.50	14	Gray	14.5	4.7	2.5	1000

▲ See Square D Digest for additional accessories including marking flags.

### Single and Double Ferrules or Cable Ends

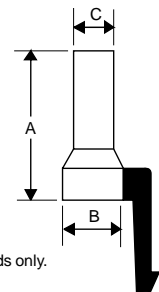
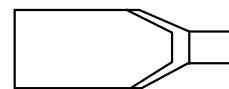
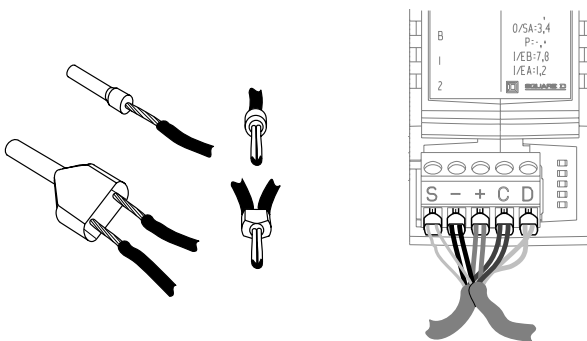

This Clip is on the markable cable ends only. It will hold up to 7 markers.

### Recommendations

When using any CBL1622XPXXX series cables, use the DZ5CE015UL, DZ5CA015UL, or AZ5DE015 on the SERIPLEX power conductors.

Use the DZ5CE007UL, DZ5CA007UL, or the AZ5DE007 for the signal pair and the shield.

### Accessories

Catalog Number	Description
AT1PA7	Automatic stripping and cutting tool for 0.08 mm to 4 mm cable, adjustable stripping length
AT1PA2	Crimping tool for cable ends 0.5 mm to 16 mm
AT1HB2	Organizing case for cable ends – holds stripping tool and cable ends (not supplied)



# SERIPLEX® Intelligent Wiring System

## Product Information — Accessories

### SET-UP TOOL



The SERIPLEX Set-up Tool is a portable device used to enter and read configuration data from SERIPLEX I/O devices that contain a SERIPLEX ASIC1 or ASIC2 chip. The Set-up Tool is connected to an I/O device by means of a short set-up cable, and data is transferred to or from the device according to user commands.

#### Key Features:

- Easy operation based on menus and graphically-labeled command keys
- Supports SERIPLEX Version 1 devices (containing the ASIC1 chip) and Version 2 devices (containing the ASIC2 chip) made by Square D and others
- 8-line by 21-character LCD display with adjustable intensity
- Small and lightweight -- fits easily in one hand
- RS-232 serial port for exchanging device set-up information with a computer
- Set-Up Utility software for entering and storing device set-up data
- Powered by 110 Vac adapter or 4 AA batteries (both included)
- Includes ASIC2 I/O Module set-up cable (SPX HH2Y2CABLE)

#### Set-up Cables:

A set-up cable is required to connect the Set-up Tool to a SERIPLEX I/O device. In some cases, an adapter may also be required. The Set-Up Tool is provided with the SPX HH2Y2CABLE set-up cable.

For this device	Use set-up cable	With this adapter
Square D Version 1 SERIPLEX I/O Modules	SPX HH1A1CABLE	(None)
Square D SERIPLEX I/O Modules	SPX HH2Y2CABLE or SPX HH2A2CABLE	(None)
Square D SERIPLEX Dedicated (Embedded) Devices	SPX HH2Y2CABLE or SPX HH2D2CABLE	(None)
Square D SPX XUJ photo sensor with pigtail cable	SPX HH2Y2CABLE or SPX HH2A2CABLE	SPX TJUNCT
Square D SPX XUJ photo sensor with 5-pin micro connector	SPX HH2Y2CABLE or SPX HH2A2CABLE	SPX UQ5ADAPT
Square D SPX XUJ photo sensor with 5-pin mini connector	SPX HH2P2CABLE	(None)
	SPX HH2Y2CABLE or SPX HH2A2CABLE	SPX MQ5ADAPT
Square D SPX XUJ photo sensor with 7-pin mini connector	SPX HH2Y2CABLE or SPX HH2A2CABLE	SPX MQ7ADAPT
	SPX HH2P2CABLE	(None)
Square D BW Pendant	SPX HH2Y2CABLE or SPX HH2A2CABLE	SPX MQ5ADAPT
Square D SPX MUXADIO001 or MUXADIO002	SPX HH2A2CABLE or SPX HH2Y2CABLE	SPX MUXCBLADPT
Square D SPX MUXADIO110, MUXADIO200, or MUXADIO210	SPX HH2Y2CABLE or SPX HH2D2CABLE	(None)
Square D high-density I/O	SPX HH2A2CABLE or SPX HH2Y2CABLE	IBCBLADPT
Other devices	Consult device manufacturer	

### Catalog Numbers

Set-up Tool	
SPX SST2	SERIPLEX Set-up Tool
Set-up Cables and Accessories	
SPX HH1A1CABLE	Set-up Cable for SERIPLEX ASIC1 I/O modules
SPX HH2A2CABLE	Set-up Cable for SERIPLEX ASIC2 I/O modules
SPX HH2D2CABLE	Set-up Cable for SERIPLEX ASIC2 embedded products
SPX HH2P2CABLE	Set-up Cable for Square D SERIPLEX operator pendants
SPX HH2Y2CABLE	Dual set-up cable for SERIPLEX I/O and embedded products
SPX MUXCBLADPT	Set-up Cable Adapter for Square D MuxADIO card
SPX UQ5ADAPT	Set-up Cable Adapter for 5-pin micro-style connector
SPX MQ5ADAPT	Set-up Cable Adapter for 5-pin mini-style connector
SPX MQ7ADAPT	Set-up Cable Adapter for 7-pin mini-style connector
IBCBLADPT	Set-up Cable Adapter for Square D SERIPLEX high-density I/O
Spare Parts	
SPX SSTACADPT	110Vac adapter for SERIPLEX Set-up Tool
SPX SSTBDOOR	Battery door for SERIPLEX Set-up Tool

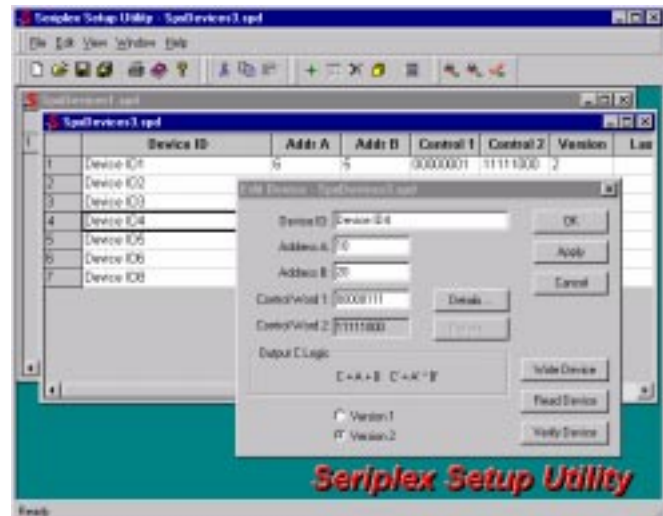

Enter and store data through the Setup Utility

### Specifications

Batteries	4 AA Alkaline
Battery life	100 Read or Write cycles typical with original equipment batteries
AC adapter input	104 to 132 Vac, 57 to 63 Hz
AC adapter output	5.0 or 6.0 Vdc, 600 mA
DC input voltage	4.6 to 6.5 Vdc
DC input current	300 mA typical, 500 mA max
Device I/O current draw	100 mA max at 17 Vdc
I/O device temperature during programming	Typically 0 to 60°C (32 to 140° F)
Operating temperature	0 to 60°C (32 to 140° F)
Storage temperature	-20 to 80°C (-4 to 176° F)
Relative humidity	0 to 90% up to 60°C (140° F), 0 to 60% above 60°C (140° F)



# SERIPLEX® Intelligent Wiring System Product Information — Accessories

## TOOLBOX SOFTWARE

SERIPLEX® Toolbox Software is a Microsoft® Windows-hosted computer program which can be used to help design and commission a SERIPLEX-based control system. It provides functions to help system designers perform the following tasks:

- Design a SERIPLEX bus system
- Verify that the system meets worst-case design guidelines
- Document the system design
- Test and troubleshoot the system
- Set up SERIPLEX I/O devices

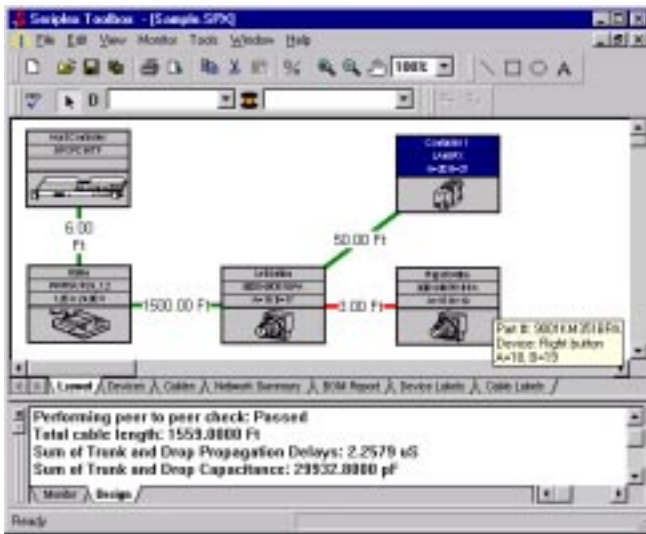

## Key Features

- Graphical drag-and-drop design of bus system
- Automatic Bill of Material generation
- Ready-made system documentation: system layout, device and cable parameters, and label printing
- Design rule checking identifies potential problems before the system is installed
- Monitor mode goes on-line to set and view actual bus data and detect bus faults and causes (Windows NT® only)
- Upload and download device set-up data through computer serial port and SPXSST2 SERIPLEX Set-Up Tool
- Compatible with Microsoft Windows 95, 98, or NT (Monitor mode available only under Windows NT)
- Includes profiles for complete SERIPLEX Version 2 product offering, with capability to add new devices
- Add comments and annotations to system layout drawing
- Customizable design rules

## System Requirements

- Computer operating Microsoft Windows 95, 98, or NT operating system (Windows NT required for Monitor functions)
- At least 24 MB RAM
- At least 10 MB hard disk space available
- Display with VGA resolution (640 x 480) or greater
- Square D Version 2 SERIPLEX CPU Interface Card (for Monitor functions)

Download SERIPLEX Toolbox Software FREE OF CHARGE from [www.squared.com](http://www.squared.com), or [www.seriplex.org](http://www.seriplex.org).



# SERIPLEX® Intelligent Wiring System

## Product Information — Accessories

### CONDITIONING MODULES



#### Features

Catalog No.	Electrical Isolation	Input Signal (From Field Device)	Output Signal (to PLC)	Std. Pack	Weight lb.kg
ABA6TA12A	Without	0-10 Vdc	4-20 mA	1	.14/0.065
ABA6TA13A			0-20 mA	1	.14/0.065
ABA6TA21A		4-20 mA	0-10 Vdc	1	.14/0.065
ABA6TA31A		0-20 mA	0-10 Vdc	1	.15/0.065
ABA6TA00B	With	±10 Vdc	±10 Vdc	1	.14/0.065
ABA6TA13B		0-10 Vdc	0-20 mA	1	.14/0.065
ABA6TA21B		4-20 mA	0-10 Vdc	1	.14/0.065
ABA6TA23B			0-20 mA	1	.14/0.065
ABA6TA31B		0-20 mA	0-10 Vdc	1	.15/0.065
ABA6TA33B			0-20 mA	1	.15/0.065
ABA6TA32B			4-20 mA	1	.15/0.065

The functions of the voltage/current analog transmitter in automated control and monitoring systems include:

- adapting signals sent from sensors to make them compatible with the receiving equipment (regulator; PLC; measurement station, etc.)
- adapting output signals (setpoints) sent from processing units (PLCs; PCs; etc.) to preactuators (speed controllers; regulators; progressive valves, etc.)
- increasing the transmission distance and providing good immunity against interference (transforming a voltage signal to a current signal)

#### Dimensions

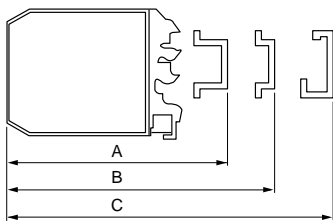

#### ABA-6TA●●A

	Inches	mm
A	3.86	98.0
B	3.56	90.5
C	3.74	95.0
D	0.65	16.5
E	2.39	60.6

#### Non Isolated Transmitter

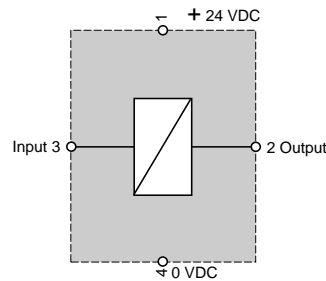

ABA-6TA●●A

#### Isolated Transmitter

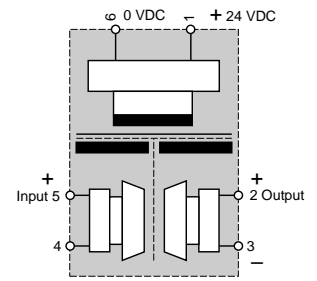

ABA-6TA●●B

The products are characterized by: a single 24 Vdc power source; a high level of precision; and a high passband of up to 100 Hz which is suitable for most industrial process applications.

The ABA-6TA range is comprised of 2 types:

- **Non-isolated transmitters:** These interfaces are designed for applications where electrical isolation between the input and the output is not required.
- **Isolated transmitters:** These interfaces are designed for applications where electrical isolation between the transmitting and receiving equipment is necessary. They provide isolation between the signals themselves, and between the signals and the 24 Vdc interface supply.

The screw clamp terminals provide secure termination of one or two (stranded or solid) wires. The terminals are shipped backed out so that each terminal is ready to accept wires right out of the box, saving on installation time. Combination head screws are used to ease installation. All terminals are clearly marked to ease wiring. Has location for 5 character (number and/or letter) terminal identification. Mounts on the common 35 mm DIN 3 or the DIN 1 track.

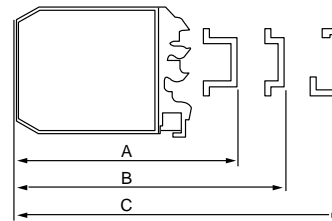

#### ABA-6TA●●B

	Inches	mm
A	3.86	98.0
B	3.56	90.5
C	3.74	95.0
D	0.89	22.5
E	2.39	60.6



# SERIPLEX® Intelligent Wiring System

## Product Information — Accessories

### Specifications

Approvals	UL File E39281, CSA File LR89150-13 and IEC		
Conforming to standards	IEC 9471; VDE 0110b, UL 508		
Degree of protection	Conforming to IEC 529 (protection against direct contact)		IP 20B
Protective treatment			Tropical Climate
Flame resistance	Conforming to IEC 695-2-1	Incandescent wire	1562°F/850°C
Shock resistance	Conforming to IEC 68227	Semi-sinusoidal waves 11 ms	50 g
Vibration resistance	Conforming to IEC 6826	10-55 Hz	5 g
Resistance to electrostatic discharges	Conforming to IEC 8012	Level 3	kV 8
Radio Frequency Immunity	Conforming to IEC 801-3	Level 3	V/m 10
Resistance to rapid transients	Conforming to IEC 8014 Level 3	On supply	kV 2
		On I/O	kV 1
Resistance to shock waves	Conforming to IEC 2554	Waveform 1.2/50 $\mu$ s; 0.5 J	kV 0.5
Cross-sections which may be connected	Flexible cable, no cable end	1 wire	20 to 14 AWG / 0.5 to 2.5 mm <sup>2</sup>
	Flexible cable with cable end	1 wire	24 to 14 AWG / 0.22 to 2.5 mm <sup>2</sup>
		2-wire	24 to 18 AWG / 0.2 to 1.5 mm <sup>2</sup>
	Solid cable	1 wire	20 to 14 AWG / 0.5 to 2.5 mm <sup>2</sup>
Operating position	Any		
Ambient air temperature around the device	Operation	Mounted vertically, touching	32 to 122°F / 0 to 50°C
		Devices 2 cm apart	32 to 140°F / 0 to 60°C
	Storage		-40 to 185°F / -40 to 85°C
Insulation voltage	Terminals/fixing rails		kV 2
Installation category	Conforming to IEC 9471		II
Degree of pollution	Conforming to IEC 9471		2
Mounting	Standard rails		

### Connections

#### ▲Non Isolated and ▼Isolated Transmitters

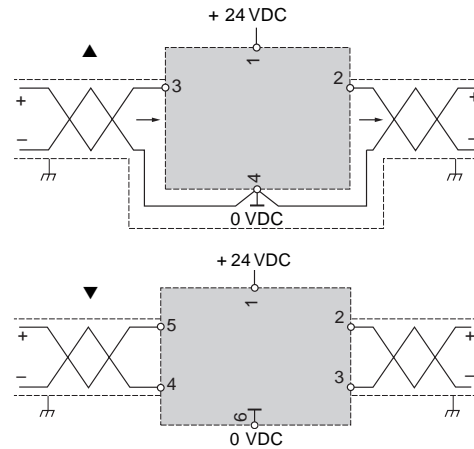

The principles of analog measurement must be observed, in particular:

- Shielded twisted pair cable should be used, minimum cross-section 24AWG/0.22 mm<sup>2</sup>.
- Only circuits with the same ground should be connected in the same multipair cable.
- The measurement cables should be kept separate from the discrete I/O cables (especially those of relay outputs) and power cables.
- Parallel routing should be avoided (there should be at least 7.8in/20 cm between cables) and intersections should be at right angles. Connect the shield to the ground of the receiver component.



# SERIPLEX® Intelligent Wiring System

## Product Information — Accessories

### Special Characteristics

Type of interface				ABA-6TA●●A (Non Isolated)	ABA-6TA●●B (Isolated)	
Supply		Supply voltage	Vdc	24 ± 20% including ripple	24 ± 20% including ripple	
		Maximum voltage without damage	Vdc	30	30	
	Maximum current	Voltage output	mA	27	102	
		Current output	mA	42	117	
		Built-in protection		Reversed polarity	Reversed polarity	
Input	Voltage	Range	Vdc	0 - 10	0 - 10 / ± 10	
		Filtering		LC filter	LC filter	
		Passband	Hz	100	100	
		Attenuation (F > 100 Hz)	%/kHz	1	1	
		Maximum voltage in common mode	Vdc	NA	15	
		Maximum voltage in serial mode	Vdc	60	60	
		Vdc input impedance	k Ohm	≥ 200	≥ 200	
			Built-in protection		Reversed polarity	Reversed polarity
	Current	Range	mA	0 - 20; 4 - 20	0 - 20; 4 - 20	
		Filtering		LC filter	LC filter	
		Passband	Hz	100	100	
		Maximum voltage in common mode	Vdc	NA	15	
		Maximum voltage in serial mode	Vdc	3.5	3.5	
		Vdc input impedance	Ohm	50	50	
			Built-in protection		Reversed polarity	Reversed polarity
Output	Voltage	Range	Vdc	0 - 10	0 - 10 / ± 10	
		Maximum voltage in common mode	Vdc	NA	630	
		Maximum voltage in serial mode	Vdc	60	60	
		Vdc output impedance	Ohm	100	100	
		Minimum load	kOhm	100	100	
		Residual ripple		NA	30 mV; 40 kHz	
				Built-in protection		Reversed polarity
	Current	Range	mA	0 - 20; 4 - 20	0 - 20; 4 - 20	
		Maximum voltage in common mode	Vdc	NA	630	
		Maximum voltage in serial mode	Vdc	3.5	3.5	
		Vdc output impedance	m Ohm	5	5	
		Maximum load	Ohm	500	500	
		Residual ripple		NA	30 mV; 40 kHz	
				Built-in protection		Reversed polarity
Transfer		Error at 68 °F/20 °C	%	± 0.2 full scale	± 0.1 full scale	
		Error on 32 to 140 °F/ 0 to 60°C range	%	± 0.8 full scale	± 0.9 full scale	
		Temperature error coefficient	%/°K	± 0.015 full scale	± 0.02 full scale	
Isolation		I/O	kV	NA	1.5	
		Input and output/supply	kV	NA	1.5	

### Analog signals

Electrical isolation	Input (From Field Device)	Output (to PLC)			
		± 10 V	0-10 V	4-20 mA	0-20 mA
Without	0-10 Vdc	No	No	Yes	Yes
	4-20 mA	No	Yes	No	No
	0-20 mA	No	Yes	No	No
With	± 10 Vdc	Yes	No	No	No
	0-10 Vdc	No	Yes ■	No	Yes
	4-20 mA	No	Yes	Yes ▲	Yes
	0-20 mA	No	Yes	Yes	Yes

■ By using ± 10 V model

▲ By using 0-20 mA model



# SERIPLEX® Intelligent Wiring System

## Appendix A — Host Interfaces

STAND-ALONE (PEER-TO-PEER) HOSTS				
	Product Name / Catalog Number	Vendor	Phone	Website
	SPX Clock	Square D Co.		www.squared.com
	ASC	NR&D	800-235-6723	www.niobrara.com

BACKPLANE CPU INTERFACES				
Interface to:	Product Name / Catalog Number	Vendor	Phone	Website
PC (ISA Bus)	SPX PCINTFV2	Square D Co.	919-266-8600	www.squared.com
VME Bus	SPX VME6U1V2	Square D Co.	919-266-8600	www.squared.com
PC/104 Bus	SPX PC104INTFV2	Square D Co.	919-266-8600	www.squared.com
Allen-Bradley PLC5 VME	SERIPLEX Driver (requires Square D SPX VME6U1V2 card)	Elite Engineering	810-752-5977	
GE-Fanuc 90/70 PLC	SERIPLEX Driver (requires Square D SPX VME6U1V2 card)	Elite Engineering	810-752-5977	
Modicon TSX Momentum PLC	170 ANM 050 10	Square D Co.	919-266-8600	www.squared.com
Modicon TSX Quantum PLC	QSPXM	NR&D	800-235-6723	www.niobrara.com
SY/MAX PLC	SPXM	NR&D	800-235-6723	www.niobrara.com

NETWORK GATEWAYS					
Network:	Example Hosts	Product Name / Catalog Number	Vendor	Phone	Website
Modbus Plus	Modicon PLC's	170ANM05010 and: 170NEF11021, 170NEF16021, 170PNT11020, or 170PNT16020	Square D / Modicon	800-468-5342	www.squared.com www.modicon.com
Modbus Plus	Modicon PLC's	BG-3500	Panel-Tec	800-869-2026	www.panel-tec.com
Profibus DP	Siemens PLC's	170ANM05010 and 170DNT11000	Square D / Modicon	800-468-5342	www.squared.com www.modicon.com
Ethernet	Computers and PLC's	170ANM05010 and 170ENT11000	Square D / Modicon	800-468-5342	www.squared.com www.modicon.com
FIPIO	Modicon TSX Micro PLC Modicon TSX Premium PLC	170ANM05010 and 170FNT11001	Square D / Modicon	800-468-5342	www.squared.com www.modicon.com
Interbus S I/O Bus	Modicon PLC's Siemens PLC's	170ANM05010 and: 170INT11000 or 170INT12000	Square D / Modicon	800-468-5342	www.squared.com www.modicon.com
DeviceNet	Allen-Bradley PLC's	170ANM05010 and 170LNT71000	Square D / Modicon	800-468-5342	www.squared.com www.modicon.com
ControlNet	Allen-Bradley PLC's	170ANM05010 and 170LNT81000	Square D / Modicon	800-468-5342	www.squared.com www.modicon.com
Allen-Bradley Data Highway+ Allen-Bradley Remote I/O Many others	Allen-Bradley PLC's	X-Link	SST (Woodhead)	519-725-5136	www.sstech.on.ca
General Serial Interface	GE-Fanuc PLC's Omron PLC's Idec PLC's Mitsubishi PLC's SY/MAX PLC's Telemecanique PLC's	SD-3000	Panel-Tec	800-869-2026	www.panel-tec.com

PC SOFTWARE DRIVERS (Required Backplane CPU Interface)					
Software Package	Software Vendor	Driver Name / Catalog Number	Driver Vendor	Phone	Website
ASIC-100, 200, 300	Xycom Automation - ASAP	SERIPLEX	Xycom Automation - ASAP	440-247-9216	www.xycom.com
Think & Do	Think & Do Software	SERIPLEX	Think & DO Software	800-722-6875	www.thinkndo.com
GELLO	Event Technologies	SERIPLEX	Event Technologies	414-427-8002	www.gello.com
Visual Logic Controller	Steeplechase	Square D SERIPLEX SPLX RIO	Steeplechase	734-975-8100	www.steeplechase.com
Soft PLC	Tele-Denken	SERIPLEX	Tele-Denken	800-763-8752	www.softpic.com
OpenControl	Nematron	SERIPLEX	Nematron	800-636-2876	www.nematron.com
Factory Suite	Wonderware	APC SERIPLEX	Standard Automation	281-334-3293	www.stdauto.com



# SERIPLEX® Intelligent Wiring System

## Appendix B — Selection Guide

Square D Product Family	Catalog Numbers	Catalog Pages	Product Description	Product Type				Enclosure Designation		Connector Type		
				Universal	Embedded Dedicated	Embedded Integrated	OEM Speciality Products	In the Panel	Out of the Panel	Screw Terminal	IDC	Mini-style Sealed Connector
Discrete I/O Modules	SPX2A2A2AV2 SPX02A2AV2 SPX2A0V2 SPX2D2D2AV2 SPX02D2AV2 SPX2D0V2 SPX2DS2D2AV2 SPX2DS0V2 SPX2D2A2AV2	13 - 15	Universal discrete I/O modules 2 input, 2 output or combo 2 in and 2 out	✓				✓		✓		
General Purpose Relay	8501 SPX11	16 - 17	SPST relay output DIN or panel mount	✓				✓			✓	
Medium Density Discrete Input Module	SPX8D0V2	18 - 19	An eight-input I/O module, DC discrete inputs	✓				✓		✓		
Medium Density Discrete Output Module	SPX08D50MAV2	18 - 19	An eight-output I/O module, DC discrete 50mA outputs	✓				✓		✓		
Analog Input Module	SPXAIN12X4V2	20 - 21	A four channel analog input module	✓				✓		✓		
Analog Output Module	SPXAOUT12X4V2	22 - 23	A four channel analog output module	✓				✓		✓		
High Density Discrete I/O	SPX24D24D200MA (for specialty OEM applications only)	24 - 25	24-input and 24-output discrete I/O on a single edge card				✓	✓		✓		
High Density Analog I/O	Many (for specialty OEM applications only)	26 - 27	Up to 16 analog inputs and 16 analog outputs on a single edge card				✓	✓				
30mm Push Button Modules Non-Illuminated	9001KA61 9001KA62 9001KA63	28 - 29	Modules for Class 9001 Type K, SK, KX and T push buttons			✓		✓		✓		
30mm Push Button Modules Illuminated	9001KA60KM 9001KA61KM 9001KA62KM 9001KA63KM	28 - 29	Modules for Class 9001 Type K, SK, KX, and T push buttons with a 9001 KM light module		✓			✓			✓	
30mm Push Button Modules Illuminated, Bus Powered	9001KA350BP (A,G,R) 9001KA351BP (A,G,R) 9001KA352BP (A,G,R) 9001KA353BP (A,G,R)	28 - 29	Modules for Class 9001 Type K, SK, KX and T push buttons with a bus powered, LED lamp output (amber, green or red)			✓		✓			✓	
Material Pull Pendant Station	SPXBWPEND5 9001AEQ3370 9001AEQ3438	36 - 37	A 9001BW pendant with a push button input and various forms of LED lamp outputs			✓		✓			✓	✓
Embedded XUJ Photosensor	SPXXUJL9 SPXXUJUQ5	38 - 39	Communication module for creating SERIPLEX embedded XUJ photosensors			✓		✓				✓ (pigtail ver. avl. also)
IEC Style Contactor Adaptor Module	LA4SPX	40	Control module for Telemecanique D- Line relays and contactors		✓			✓			✓	
NEMA Style Contactor Adaptor Module	9999SK04	41	Control module for NEMA Type S contactors and starters (Sizes 00 - 4)		✓			✓			✓	
2 Input, 2 Output Enclosed I/O	8930CEQ6475-G1		A NEMA 4X enclosure with one SERIPLEX I/O module, 7 terminal blocks, cable glands				✓	✓		✓		
4 Input, 4 Output Enclosed I/O	8930CEQ6475-G2		A NEMA 4X enclosure with 2 SERIPLEX I/O modules, 12 terminal blocks, cable glands				✓	✓		✓		
1 Enclosed IEC D-Line Starter	8930CEQ6479-G1	37	An enclosed IEC starter (NEMA 12 enclosure), loadbreak "V" switch, 3 terminal blocks and SERIPLEX control				✓	✓		✓		
2 Enclosed IEC D-Line Starters	8930CEQ6479-G2	37	Two IEC starters enclosed in a NEMA 12 box, loadbreak "V" switch, 6 terminal blocks and SERIPLEX control				✓	✓		✓		
2 Input, 2 Output Enclosed I/O with Mini-style Quick Connectors	8930CEQ6458-G1		A NEMA 12 enclosure with 2 micro-style input and, 2 micro-style output connections, for I/O monitoring and control. Seven-pin mini-style connector used for the SERIPLEX control but.				✓	✓				✓



# SERIPLEX® Intelligent Wiring System

## Appendix B — Selection Guide

I/O Type		I/O Power Supply		Control Bus Interface Circuitry			Typical # of Addresses Required (without CDR initiated)	Data Verification User Options			
Inputs	Outputs	Bus Powered	Auxiliary Powered	Standard	Multi-bit	Multiplexed		Digital Debounce	Data Echo	CDR	Health Bit
Options: Solid State AC Solid State DC Hard Contact No Input	Options: 2 Amp AC 2 Amp DC Not Output	✓ (hard contact inputs only)	✓ (except hard contact inputs)	✓			2	✓	✓		
"Health Bit"	2.5 Amp Relay Output		✓	✓			1	✓	✓		✓
Solid State DC Inputs (sink or source)	None		✓		✓		8			✓	
None	50 mA DC Solid State		✓		✓		8			✓	
Field Selectable Options: 0-5 Volt / 0-10 Volt / 0-20 mA Single ended or differential	None		✓		✓		16			✓	
None	Field Selectable Options: 0-5 Volt / 0-10 Volt Bipolar Offset: -2.5, -5.0, -10.0 VDC		✓		✓	✓	16			✓	
Options: Solid State DC No Input	200 mA per Output 2.4 Amps per Board		✓		✓	✓	24				
Options: 0-5 volt / 0-10 volt	Options: 0-5 Volt / 0-10 Volt		✓		✓	✓	16				
Options: N.O. / N.C. / N.O. and N.C. (signal placed directly on the bus)	None	✓		✓			1 or 2	✓ (avl. but not needed)	✓ (avl. but not needed)		✓ (some)
Options: N.O. / N.C. N.O. and N.C. (signal placed directly on the bus)	2.5 Amp Relay		✓✓	✓			1 or 2	✓	✓		✓ (some)
Options: N.O. / N.C. N.O. and N.C. (signal placed directly on the bus)	Bus Powered LED Lamp	✓		✓			1 or 2	✓ (avl. but not needed)	✓ (avl. but not needed)		✓ (some)
1) N.O. Input push button signal 2) "Health-bit" signal	Bus Powered LED Lamp	✓		✓			1 or 2	✓ (avl. but not needed)	✓ (avl. but not needed)		
1) Target presence 2) "Health-bit" or marginal detection signal	Light / Dark Operation Selectability	✓		✓			2	✓ (avl. but not needed)	✓ (avl. but not needed)		✓
1) "Health-bit" and 2) Holding circuit feedback signal	2.5 Amp Relay for Coil Control		✓	✓			1 or 2	✓	✓		✓
1) "Health-bit" and 2) Holding circuit feedback signal	2.5 Amp Relay for Coil Control		✓	✓			1 or 2	✓	✓		✓
Solid State DC	2 Amp Solid State DC		✓	✓			4	✓	✓		
Solid State DC	2 Amp Solid State DC		✓	✓			4	✓	✓		
1) "Health-bit" and 2) Holding circuit feedback signal	2.5 Amp Relay for Coil Control		✓	✓			1 or 2	✓	✓		✓
1) "Health-bit" and 2) Holding circuit feedback signal	2.5 Amp Relay for Coil Control		✓	✓			2 or 4	✓	✓		✓
Solid State DC	2 Amp Solid State DC	✓		✓			2	✓	✓		











Square D Company  
8001 Highway 64 East  
Knightdale, NC 27545  
1-888-SquareD  
(1-888-778-2733)  
[www.squared.com](http://www.squared.com)

Schneider Canada Inc.  
19 Waterman Avenue,  
M4B 1 Y2  
Toronto, Ontario  
1-800-565-6699  
[www.schneider.ca](http://www.schneider.ca)

Catalog No. 8330CT9601R4/99 June 2000 © 1996-2000 Schneider Electric All Rights Reserved.  
Replaces 8330CT9601R3/97 dated April 97, 8330CT9901 dated May 99, 8330CT9902 dated May 99,  
8330CT9903 dated May 99, and 8330CT9904 dated April 99.