

Specification				
Part Number:		MCT070M6W800480LML		
Version:				
Date:				
Revision				
No.	Date	Description	Item	Page
				

CONTENTS

List	Description	Page No.
1	GENERAL SPECIFICATIONS	4
2	BLOCK DIAGRAM	5
3	DIMENSIONAL OUTLINE	6
4	PIN DESCRIPTION	7
5	ELECTRICAL CHARACTERISTICS	8
6	INPUT SIGNAL TIMING	11
7	OPTICAL CHARACTERISTICS	13
8	PACKAGE	16

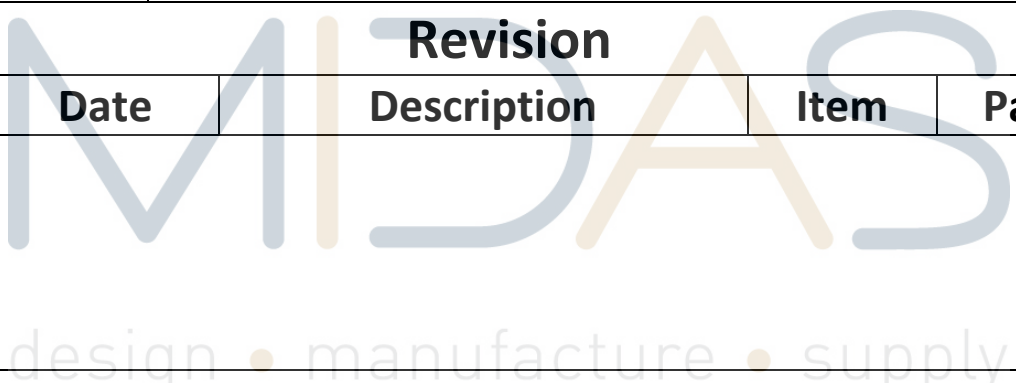

1. GENERAL SPECIFICATIONS

ITEM	SPECIFICATION	UNIT
OUTLINE DIMENSIONS	164.9 (W) X100 (H) X3.45 (D)	mm
DISPLAY SIZE	7.0	inch
DOT PITCH	0.1926mmX0.1790mm	mm
NUMBER OF DOTS	800* (RGB) *480	-
DRIVER IC	ILI5960/ILI6128B	-
LCD TYPE	TFT(16.7M) TRANSMISSIVE	-
INTERFACE	RGB 24BITS	-
BACKLIGHT TYPE	LED White	-
VIEWING DIRECTION	6 O'clock	-

*See attached drawing for details.

design • manufacture • supply

2. BLOCK DIAGRAM

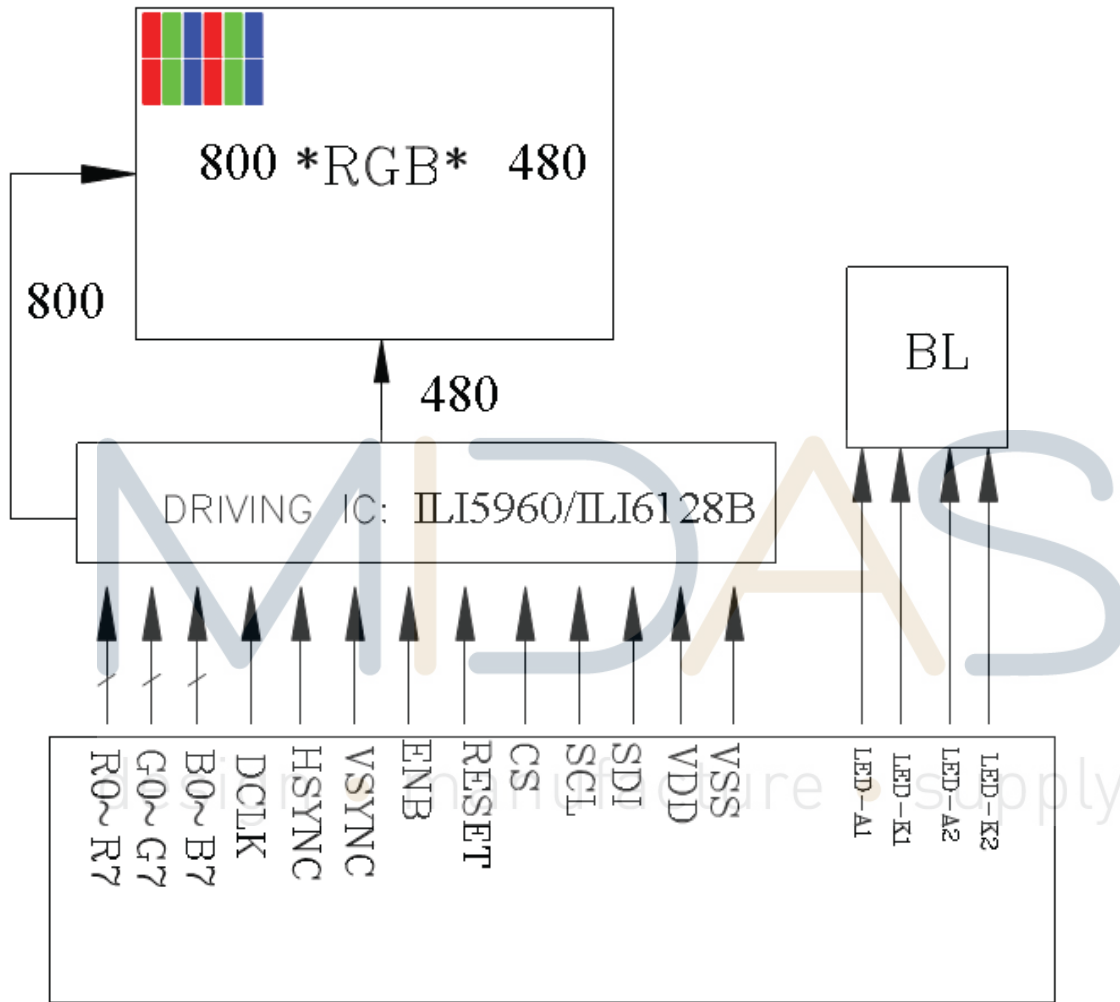

NO.	PIN NAME	Type	Description
1	LED-	P	Power supply for LED (Cathode)
2	LED+	P	Power supply for LED (Anode)
3	CS (NC)	-	No connection
4	VDD	P	Power voltage
5	R0	I	RED data signal(LSB)
6	R1	I	RED data signal
7	R2	I	RED data signal
8	R3	I	RED data signal
9	R4	I	RED data signal
10	R5	I	RED data signal
11	R6	I	RED data signal
12	R7	I	RED data signal(MSB)
13	G0	I	GREEN data signal(LSB)
14	G1	I	GREEN data signal
15	G2	I	GREEN data signal
16	G3	I	GREEN data signal
17	G4	I	GREEN data signal
18	G5	I	GREEN data signal
19	G6	I	GREEN data signal
20	G7	I	GREEN data signal(MSB)
21	B0	I	BLUE data signal(LSB)
22	B1	I	BLUE data signal
23	B2	I	BLUE data signal
24	B3	I	BLUE data signal
25	B4	I	BLUE data signal
26	B5	I	BLUE data signal
27	B6	I	BLUE data signal
28	B7	I	BLUE data signal(MSB)
29	GND	I	Ground(0V)
30	DOTCLK	I	Pixel clock signal
31	DISP	I	Display on/ off
32	HSYNC	I	Horizontal synchronizing signal
33	VSYNC	I	Vertical synchronizing signal
34	DE	I	Data enable
35	SCL (NC)	-	No connection
36	SDA (NC)	-	No connection
37	XR (NC)	-	No connection
38	YD (NC)	-	No connection
39	XL (NC)	-	No connection
40	YU (NC)	-	No connection

Note: I: input, O: output, P: Power

[Link to example connector](#)

5. ELECTRICAL CHARACTERISTICS

5.1 Absolute Maximum Ratings

Item	Symbol	Values		Unit	Remark
		Min	Max		
Power Supply for Pump	VCC	-0.3	5.0	V	
Operating temperature range	To	-20	70	Degree C	
Storage temperature range	Ts	-30	80	Degree C	
Logic input voltage range	VI	-0.3	VCC+0.3	V	
Logic input voltage range	VO	-0.3	VCC+0.3	V	

Note: Stresses beyond those given in the Absolute Maximum Rating table may cause operational errors or damage to the device. For normal operational conditions see AC/DC Electrical Characteristics

5.2 DC Characteristics

Item	Symbol	Values			Unit	Conditions
		Min	Typ	Max		
Low Level Input Voltage	Vil	GND	-	0.3xVCC	v	
High Level Input Voltage	Vih	0.7xVCC	-	VCC	uA	
High Level Output Voltage	Voh	VCC-0.4	-	VCC	ohm	
Low Level Output Voltage	Vol	GND	-	GND+0.4	uA	
Power Supply	VCC	2.8	3.3	3.6	V	
Input Leakage Current	Iil			±1.0	uA	
Pull High/Low Resistor	Rp	-	100K	-	ohm	

5.3 DC Backlight Unit

Item	Symbol	Min	Typ	Max	Unit	Remark
Average luminous Intensity	Iv		280		cd/m2	IF=60mA
Chromaticity Coordinates	X	0.234	0.284	0.334		IF=60mA
	Y	0.273	0.323	0.373		IF=60mA
Forward Voltage	VF		19.2	20.4	V	IF=60mA
Reverse Current	IR			50	μA	VR=10V, 1LED
Luminous Tolerance	IV-M	80			%	(MIN/MAX)×100
Power Dissipation	Pd	1152			mW	
Reverse Voltage	VR	5			V	

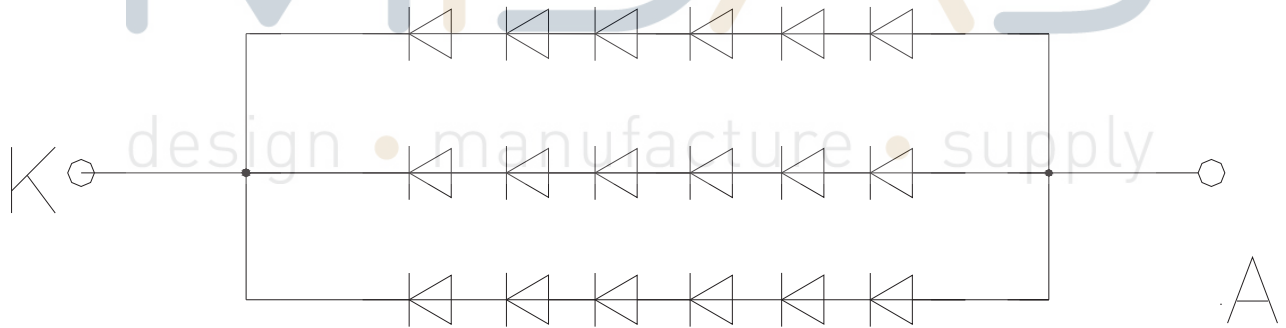

$$6 * 3 = 18 \text{ PCS}$$

5.4 Power On/Off sequence

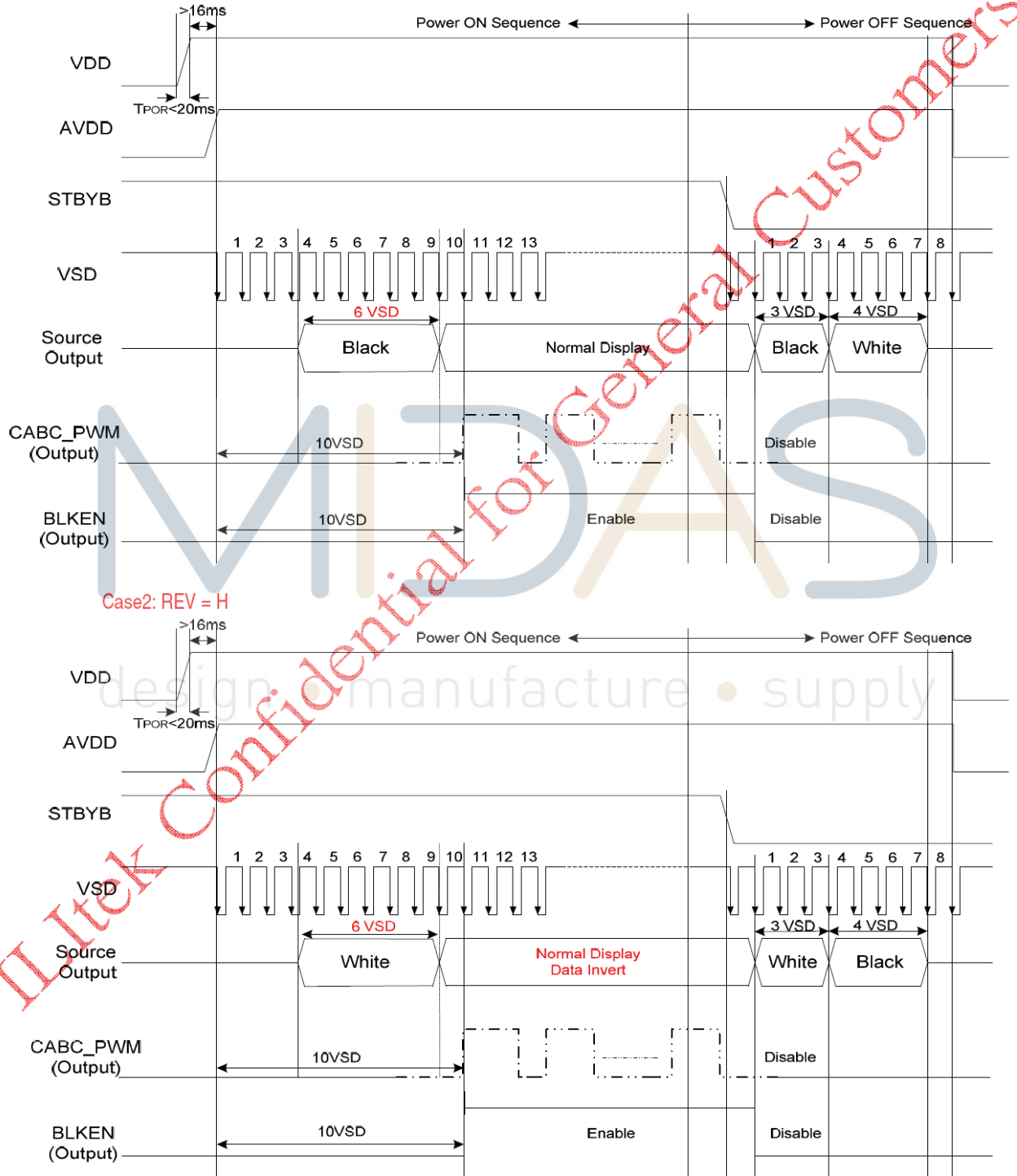

6. INPUT SIGNAL TIMING

6.1 AC Electrical Characteristics

Parameter	Symbol	Min.	Typ.	Max.	Unit	Conditions
VDD Power On Slew rate	TPOR	-	-	20	ms	From 0V to 90% VDD
RSTB pulse width	Trst	10	-	-	us	CLKIN = 45MHz
STBYB pulse width	Tstbyb	8	-	-	VS	
CLKIN cycle time	Tcph	20			ns	
CLKIN pulse duty	Tcwh	40	50	60	%	
VSD setup time	Tvst	8	-	-	ns	
VSD hold time	Tvhd	8	-	-	ns	
HSD setup time	Thst	8	-	-	ns	
HSD hold time	Thhd	8	-	-	ns	
Data set-up time	Tdsu	8	-	-	ns	D0R[7:0], D1G[7:0], D2B[7:0] to CLKIN
Data hold time	Tdhd	8	-	-	ns	D0R[7:0], D1G[7:0], D2B[7:0] to CLKIN
DE setup time	Tesu	8	-	-	ns	
DE hold time	Tehd	8	-	-	ns	
Output stable time	Tsst	-	-	6	us	10% to 90% target voltage. CL=120pF, R=10K ohm

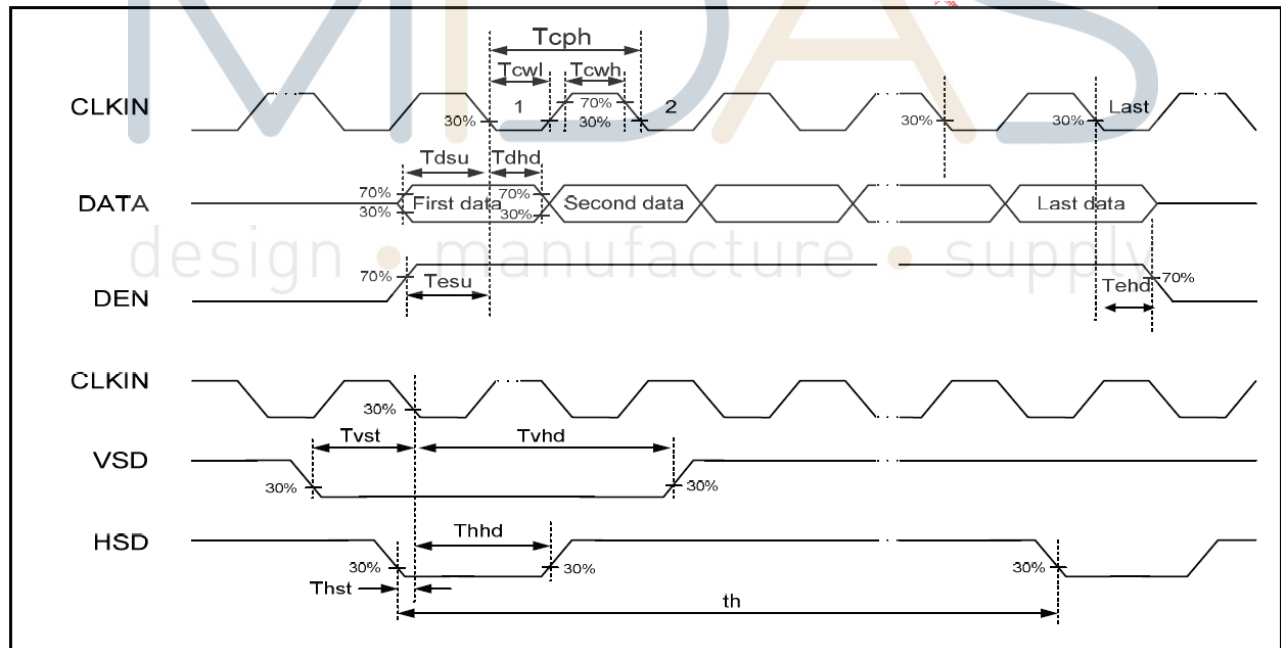

Source output timing diagram

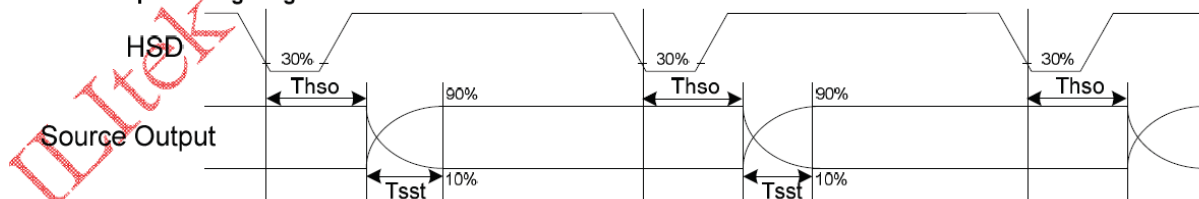

6.2 Data Transaction Timing in Parallel RGB (24 bit) Interface

Parameter	Symbol	Min.	Typ.	Max.	Unit	Conditions
CLKIN Frequency	Fclk	-	33	50	MHz	VDD = 2.7V ~3.6V
CLKIN Cycle Time	Tclk	20	30	-	ns	
CLKIN Pulse Duty	Tcwh	40	50	60	%	Tclk
Time from HSD to Source Output	Thso	-	37	-	CLKIN	
Time from HSD to LD	Thld	-	20	-	CLKIN	
Time from HSD to STV	Thstv	-	2	-	CLKIN	
Time from HSD to CKV	Thckv	-	20	-	CLKIN	
Time from HSD to OEV	Thoev	-	4	-	CLKIN	
LD Pulse Width	Twld	-	16	-	CLKIN	
CKV Pulse Width	Twckv	-	66	-	CLKIN	
OEV Pulse Width	Twoev	-	74	-	CLKIN	

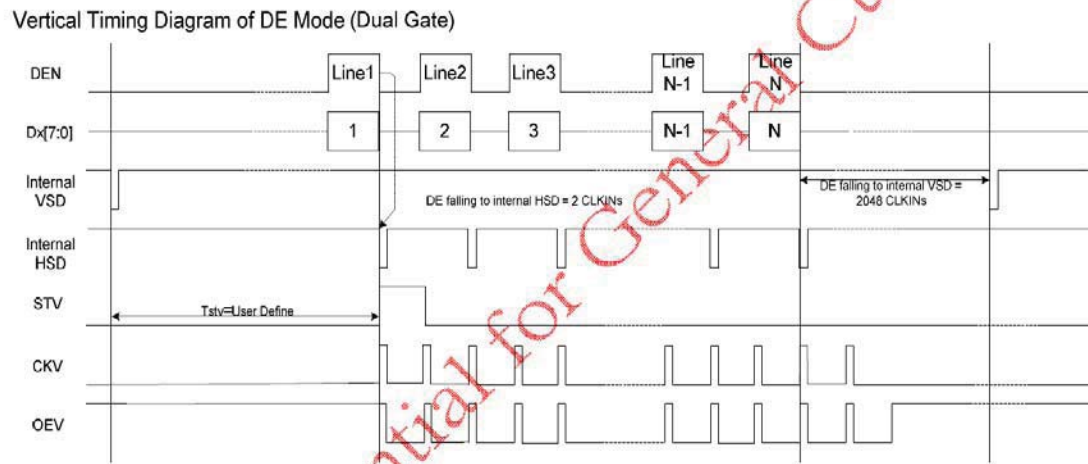
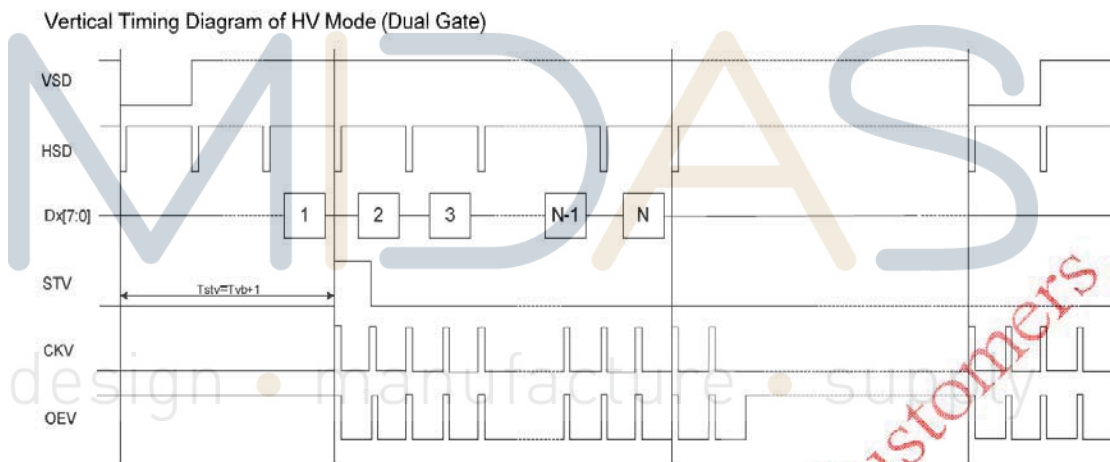

Gate Output Timing Diagram (Dual Gate)

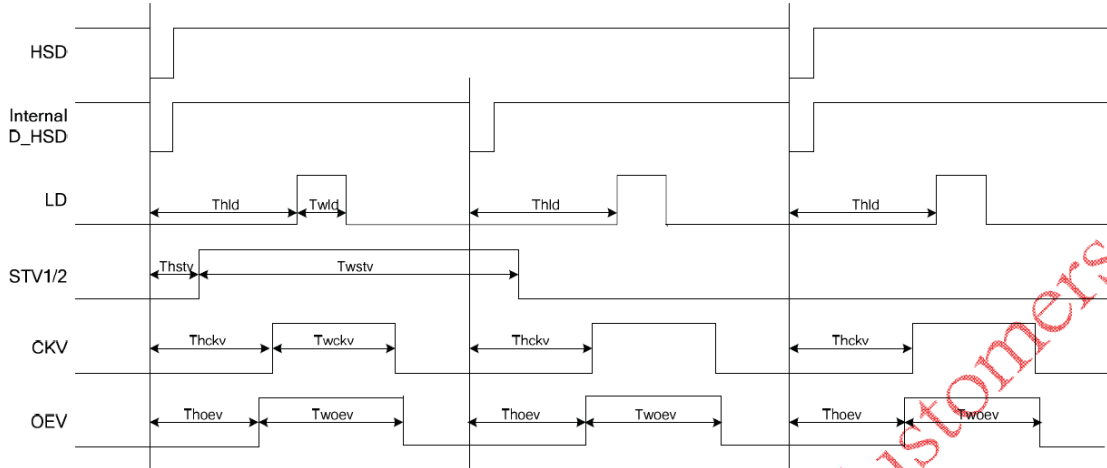

6.3 Controller Information

IC: ILI5960/ ILI6128B

7. OPTICAL CHARACTERISTICS

Parameter	Symbol	Condition	Min.	Typ.	Max.	Unit	Remark	
Viewing Angle range	Horizontal	CR > 10	Θ_3	70	75	-	Deg.	WV-Pol Note 1
			Θ_9	70	75	-	Deg.	
	Vertical		Θ_{12}	65	70	-	Deg.	
			Θ_6	70	75	-	Deg.	
Luminance Contrast ratio	CR	$\Theta = 0^\circ$	400	500	-		Note 2	
Cell Transmittance	Tr		-	6.03	-	%	Base on C Light Note 3	
White Chromaticity	X_w		0.294	0.304	0.314		Note 4 CF Glass	
	Y_w		0.329	0.339	0.349			
Reproduction of color (C light)	Red		R_x	0.586	0.601	0.616		
			R_y	0.309	0.324	0.339		
	Green		G_x	0.291	0.301	0.311		
			G_y	0.552	0.567	0.582		
Blue	B_x		0.133	0.143	0.153			
	B_y		0.159	0.174	0.189			
Color Gamut (C light)			-	50	-	%		
Response Time (Rising + Falling)	T_{RT}	$T_a = 25^\circ C$ $\Theta = 0^\circ$	-	25	-	ms	Note 5	

Note :

1. Viewing angle is the angle at which the contrast ratio is greater than 10. The viewing angles are determined for the horizontal or 3, 9 o'clock direction and the vertical or 6, 12 o'clock direction with respect to the optical axis which is normal to the LCD surface (see FIGURE 1).
2. Contrast measurements shall be made at viewing angle of $\Theta = 0$ and at the center of the LCD surface. Luminance shall be measured with all pixels in the view field set first to white, then to the dark (black) state. (see FIGURE 1) Luminance Contrast Ratio (CR) is defined mathematically.

$$CR = \frac{\text{Luminance when displaying a white raster}}{\text{Luminance when displaying a black raster}}$$

3. Transmittance is the Value with Polarizer
4. The color chromaticity coordinates specified in Table 5 shall be calculated from the spectral data measured with all pixels first in red, green, blue and white. Measurements shall be made at the center of the panel.
5. The electro-optical response time measurements shall be made as FIGURE 3 by switching the "data" input signal ON and OFF. The times needed for the luminance to change from 10% to 90% is T_r , and 90% to 10% is T_d .

Figure 2. The Definition of V_{th} & V_{sat}

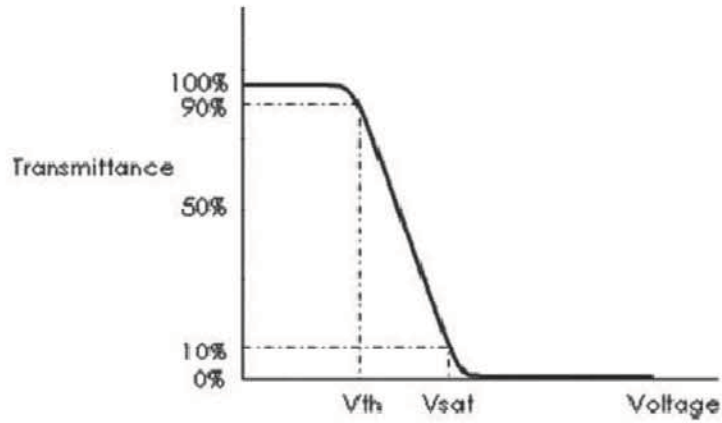

Figure 3. Measurement Set Up

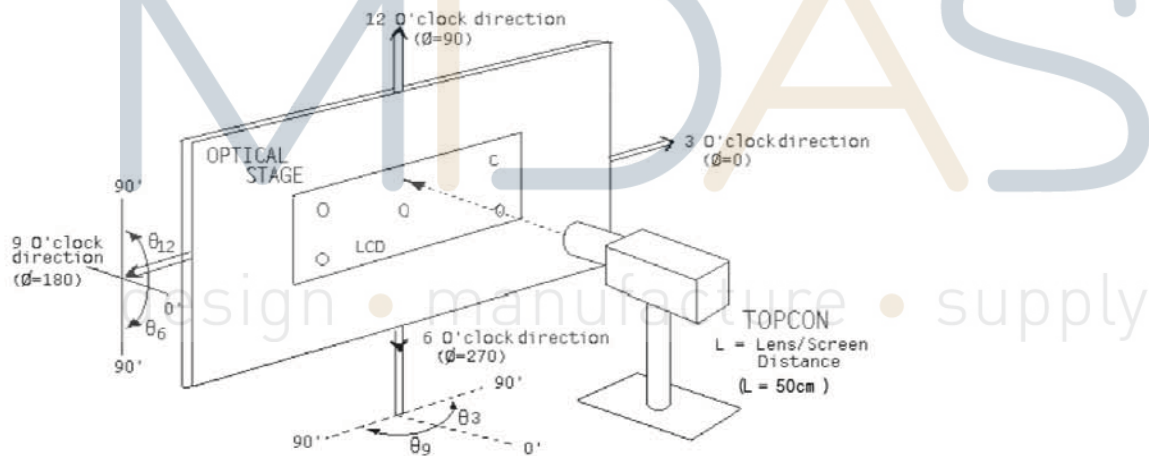
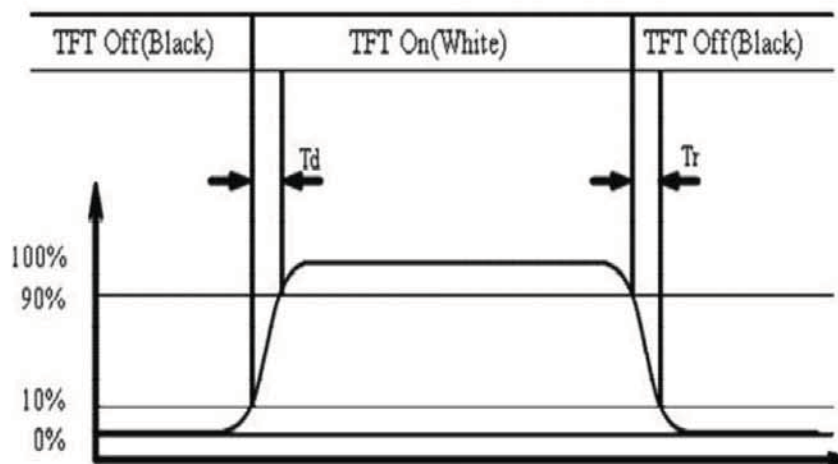

Figure 4. Response Time Testing



. PACKAGE

