

## Low-power, general-purpose operational amplifiers

Datasheet - production data

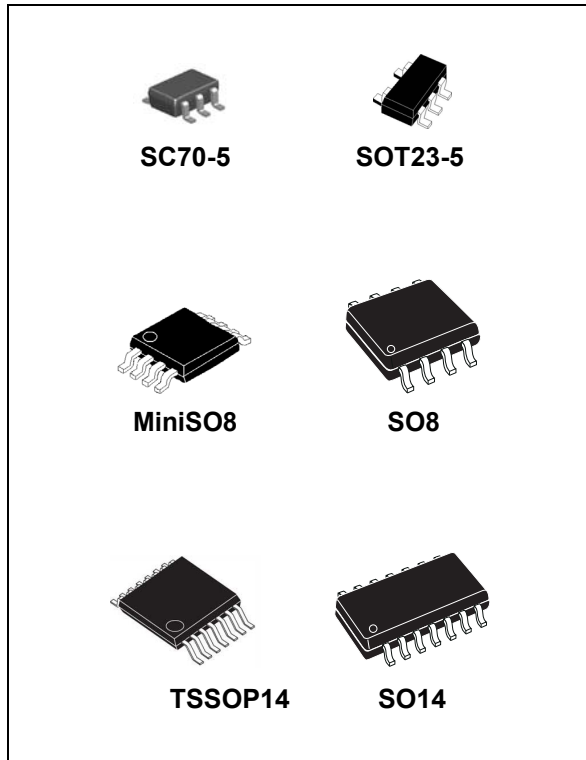

### Description

The LMV321L, LMV358L, and LMV324L are single, dual and quad operational amplifiers with rail-to-rail output capabilities. They are specifically designed to operate at low voltages (2.7 V to 5 V) with enhanced performances compared to the industry standard LM3xx series.

The LMV321L, LMV358L, and LMV324L are offered in tiny packages, allowing the devices to be used in small portable electronic applications and to be placed closer to the actual signal.

The LMV321L, LMV358L, and LMV324L are complete cost-effective solutions for application designs where cost is of primary importance.

### Features

- Low-power consumption: 250  $\mu$ A max at 5 V
- Low offset voltage: 7 mV max at 25 °C
- Industrial temperature range: -40 °C to +125 °C
- Low supply voltage: 2.7 V - 5.5 V
- Gain bandwidth product: 1.3 MHz
- Tiny packages

### Applications

- Battery-powered applications
- Portable devices
- Signal conditioning
- Active filtering
- Medical instrumentation

# Contents

- 1      Package pin connections ..... 3**
- 2      Absolute maximum ratings and operating conditions ..... 4**
- 3      Electrical characteristics ..... 5**
- 4      Application information ..... 11**
  - 4.1    Operating voltages .....11
  - 4.2    Input common-mode range .....11
  - 4.3    Rail-to-rail output .....11
  - 4.4    Input offset voltage drift over temperature .....11
  - 4.5    PCB layouts .....11
  - 4.6    Macromodel .....11
- 5      Package information ..... 12**
  - 5.1    SC70-5 (SOT323-5) package ..... 13
  - 5.2    SOT23-5 package ..... 14
  - 5.3    MiniSO8 package information ..... 15
  - 5.4    SO8 package information ..... 16
  - 5.5    TSSOP14 package information ..... 17
  - 5.6    SO14 package information ..... 18
- 6      Ordering information ..... 19**
- 7      Revision history ..... 19**

# 1 Package pin connections

Figure 1. Pin connections for each package (top view)

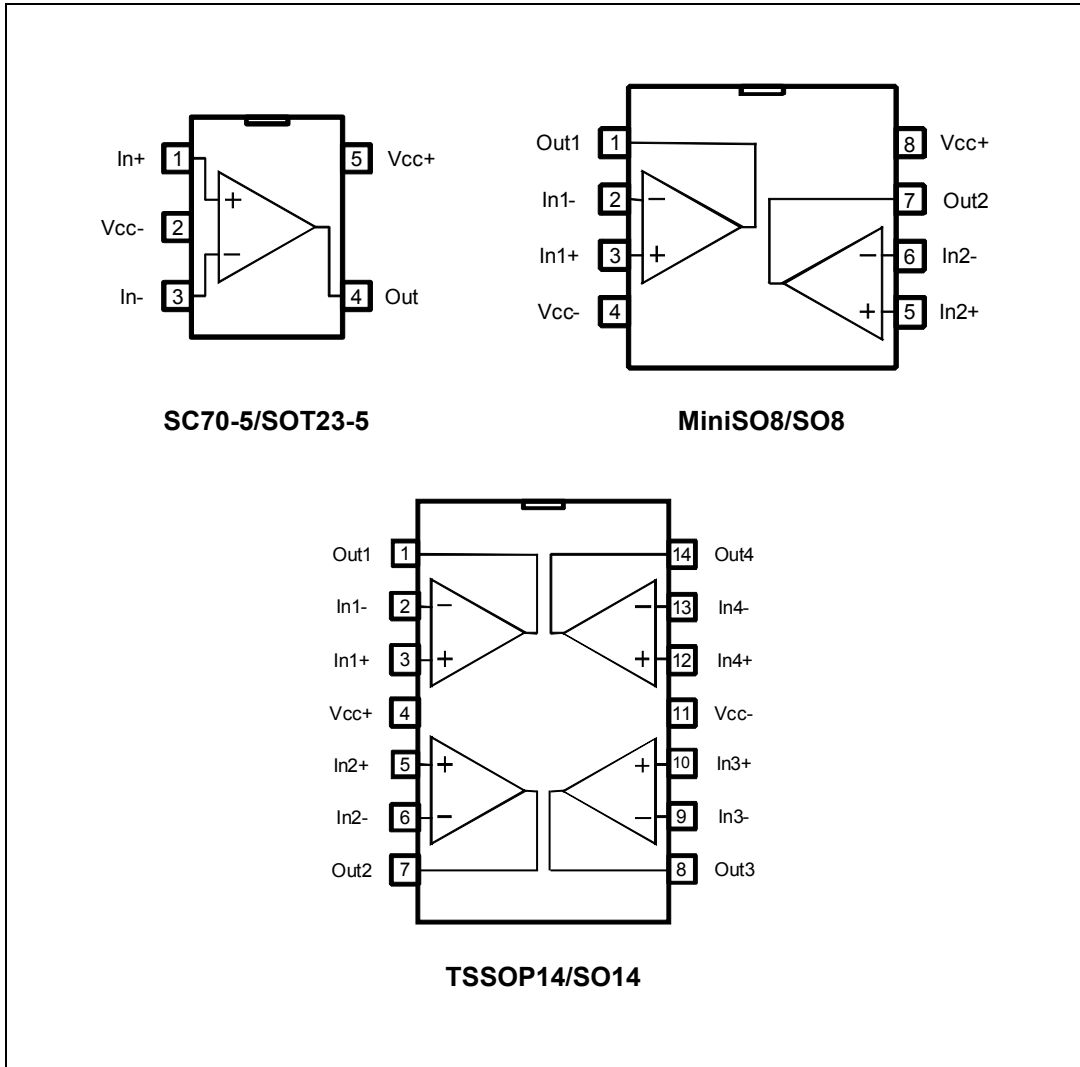

## 2 Absolute maximum ratings and operating conditions

**Table 1. Absolute maximum ratings (AMR)**

Symbol	Parameter	Value	Unit
$V_{CC}$	Supply voltage <sup>(1)</sup>	6	V
$V_{id}$	Differential input voltage <sup>(2)</sup>	$\pm V_{CC}$	
$V_{in}$	Input pins (IN+ and IN- pins) voltage <sup>(3)</sup>	$V_{CC-} - 0.3$ to $V_{CC+} + 0.2$	
$I_{in}$	Input current <sup>(4)</sup>	10	mA
$T_{stg}$	Storage temperature	-65 to +150	°C
$R_{thja}$	Thermal resistance junction to ambient <sup>(5)(6)</sup>		°C/W
	SC70-5	205	
	SOT23-5	250	
	MiniSO8	190	
	SO8	125	
	TSSOP14	100	
	SO14	105	
$T_j$	Maximum junction temperature	150	°C
ESD	HBM: human body model <sup>(7)</sup>	4000	V
	MM: machine model <sup>(8)</sup>	250	
	CDM: charged device model <sup>(9)</sup>	1300	
	Latch-up immunity	200	mA

1. All voltage values, except differential voltage, are with respect to network ground terminal.
2. Differential voltage is the non-inverting input terminal with respect to the inverting input terminal.
3.  $V_{CC-} - V_{in}$  must not exceed 6 V,  $V_{in}$  must not exceed 6 V.
4. Input current must be limited by a resistor in series with the inputs.
5. Short-circuits can cause excessive heating and destructive dissipation.
6.  $R_{th}$  are typical values.
7. Human body model: 100 pF discharged through a 1.5 kΩ resistor between two pins of the device, done for all couples of pin combinations with other pins floating.
8. Machine model: a 200 pF cap is charged to the specified voltage, then discharged directly between two pins of the device with no external series resistor (internal resistor < 5 Ω), done for all couples of pin combinations with other pins floating.
9. Charged device model: all pins plus package are charged together to the specified voltage and then discharged directly to the ground.

**Table 2. Operating conditions**

Symbol	Parameter	Value	Unit
$V_{CC}$	Supply voltage	2.7 to 5.5	V
$V_{icm}$	Common mode input voltage range	$V_{CC-} - 0.2$ to $V_{CC+} - 1$	
$T_{oper}$	Operating free-air temperature range	-40 to +125	°C

### 3 Electrical characteristics

Table 3. Electrical characteristics at  $V_{CC+} = 2.7\text{ V}$  with  $V_{CC-} = 0\text{ V}$ ,  $V_{icm} = V_{CC}/2$ ,  $T_{amb} = 25\text{ }^{\circ}\text{C}$ , and  $R_L$  connected to  $V_{CC}/2$  (unless otherwise specified)

Symbol	Parameter	Conditions	Min.	Typ.	Max.	Unit
<b>DC performance</b>						
$V_{io}$	Input offset voltage			1	7	mV
$\Delta V_{io}/\Delta T$	Input offset voltage drift <sup>(1)</sup>	$-40\text{ }^{\circ}\text{C} < T < 125\text{ }^{\circ}\text{C}$		5		$\mu\text{V}/^{\circ}\text{C}$
$I_{io}$	Input offset current	$V_{out} = V_{CC}/2$		0.5	30	nA
$I_{ib}$	Input bias current			27	60	
CMRR	Common mode rejection ratio <sup>(1)</sup>	$V_{ic} = 0\text{ V to } V_{CC}-1\text{ V}$ , $V_{out} = V_{CC}/2$	70	75		dB
$V_O$	Output swing	$R_L = 10\text{ k}\Omega$ , high level	2.6	2.69		V
		$R_L = 10\text{ k}\Omega$ , low level		65	180	mV
$I_{CC}$	Supply current (per channel)	No load, $V_{out} = V_{CC}/2$		120	180	$\mu\text{A}$
<b>AC performance</b>						
GBP	Gain bandwidth product	$R_L > 1\text{ M}\Omega$ , $C_L = 200\text{ pF}$		1.3		MHz
$\Phi_m$	Phase margin			60		degrees
$G_m$	Gain margin			10		dB
SR	Slew rate	$R_L > 1\text{ M}\Omega$ , $C_L = 200\text{ pF}$ $V_{out} = 0.5\text{ V to } V_{CC} - 0.5\text{ V}$		0.6		$\text{V}/\mu\text{s}$
$e_n$	Equivalent input noise voltage	f = 1 kHz f = 10 kHz		31 20		$\frac{\text{nV}}{\sqrt{\text{Hz}}}$
$i_n$	Equivalent input noise current	f = 1 kHz		0.30		$\frac{\text{pA}}{\sqrt{\text{Hz}}}$

1.  $\text{CMRR (dB)} = 20 \log (\Delta V_{icm}/\Delta V_{io})$ .

**Table 4. Electrical characteristics at  $V_{CC+} = 5\text{ V}$  with  $V_{CC-} = 0\text{ V}$ ,  $V_{icm} = V_{CC}/2$ ,  $T_{amb} = 25^\circ\text{ C}$ , and  $R_L$  connected to  $V_{CC}/2$  (unless otherwise specified)**

Symbol	Parameter	Conditions	Min.	Typ.	Max.	Unit	
<b>DC performance</b>							
$V_{io}$	Input offset voltage			1	7	mV	
		$-40^\circ\text{ C} < T < 125^\circ\text{ C}$			9		
$\Delta V_{io}/\Delta T$	Input offset voltage drift <sup>(1)</sup>	$-40^\circ\text{ C} < T < 125^\circ\text{ C}$		5		$\mu\text{V}/^\circ\text{ C}$	
$I_{io}$	Input offset current	$V_{out} = V_{CC}/2$		0.5	30	nA	
		$-40^\circ\text{ C} < T < 125^\circ\text{ C}$			50		
$I_{ib}$	Input bias current	$V_{out} = V_{CC}/2$		27	60	nA	
		$-40^\circ\text{ C} < T < 125^\circ\text{ C}$			110		
CMRR	Common mode rejection ratio <sup>(2)</sup>	$V_{ic} = 0\text{ V}$ to $V_{CC}-1\text{ V}$ , $V_{out} = V_{CC}/2$	72	75		dB	
SVRR	Supply voltage rejection ratio	$V_{CC} = 2.7$ to $5\text{ V}$	72	79			
$A_{vd}$	Large signal voltage gain	$R_L = 2\text{ k}\Omega$ $V_{out} = 0.5\text{ V}$ to $(V_{CC}-0.5\text{ V})$	90	100		dB	
		$-40^\circ\text{ C} < T < 125^\circ\text{ C}$	80				
$V_{OH}$	Output swing high level	$R_L = 10\text{ k}\Omega$	4.90	4.99		V	
		$R_L = 10\text{ k}\Omega$ , $-40^\circ\text{ C} < T < 125^\circ\text{ C}$	4.80				
		$R_L = 2\text{ k}\Omega$	4.70	4.96			
		$R_L = 2\text{ k}\Omega$ , $-40^\circ\text{ C} < T < 125^\circ\text{ C}$	4.60				
$V_{OL}$	Output swing low level	$R_L = 10\text{ k}\Omega$		65	180	mV	
		$R_L = 10\text{ k}\Omega$ , $-40^\circ\text{ C} < T < 125^\circ\text{ C}$			280		
		$R_L = 2\text{ k}\Omega$		120	300		
		$R_L = 2\text{ k}\Omega$ , $-40^\circ\text{ C} < T < 125^\circ\text{ C}$			400		
$I_{out}$	Output short circuit current	Sinking, $V_{out} = V_{CC}$	35	43		mA	
		Sourcing, $V_{out} = 0\text{ V}$	60	70			
$I_{CC}$	Supply current (per channel)	No load, $V_{out} = V_{CC}/2$		130	250	$\mu\text{ A}$	
		$-40^\circ\text{ C} < T < 125^\circ\text{ C}$			350		
<b>AC performance</b>							
GBP	Gain bandwidth product	$R_L > 1\text{ M}\Omega$ , $C_L = 200\text{ pF}$		1.3		MHz	
$F_u$	Unity gain frequency			1			
$\Phi_m$	Phase margin				60		degrees
$G_m$	Gain margin				10		dB
SR	Slew rate	$R_L > 1\text{ M}\Omega$ , $C_L = 200\text{ pF}$ $V_{out} = 0.5\text{ V}$ to $V_{CC} - 0.5\text{ V}$		0.7		$\text{V}/\mu\text{s}$	

**Table 4. Electrical characteristics at  $V_{CC+} = 5\text{ V}$  with  $V_{CC-} = 0\text{ V}$ ,  $V_{icm} = V_{CC}/2$ ,  $T_{amb} = 25^\circ\text{ C}$ , and  $R_L$  connected to  $V_{CC}/2$  (unless otherwise specified) (continued)**

Symbol	Parameter	Conditions	Min.	Typ.	Max.	Unit
$e_n$	Equivalent input noise voltage	f = 1 kHz f = 10 kHz		30 20		$\frac{\text{nV}}{\sqrt{\text{Hz}}}$
$i_n$	Equivalent input noise current	f = 1 kHz		0.30		$\frac{\text{pA}}{\sqrt{\text{Hz}}}$

1. See [Section 4.4: Input offset voltage drift over temperature](#).
2.  $\text{CMRR (dB)} = 20 \log (\Delta V_{icm} / \Delta V_{io})$ .

Figure 2. Supply current vs. supply voltage at  $V_{icm} = V_{CC}/2$

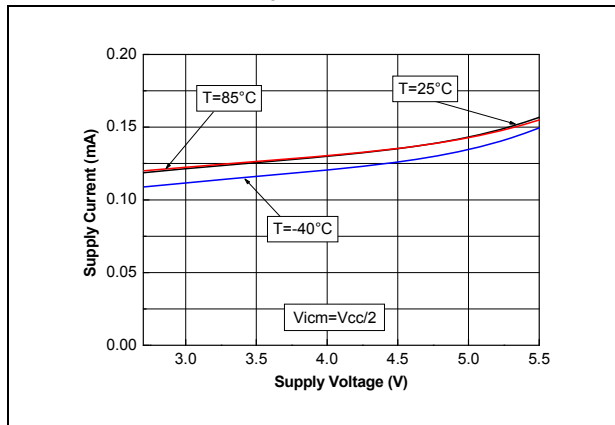

Figure 3. Input offset voltage vs. input common mode voltage at  $V_{CC} = 5\text{ V}$

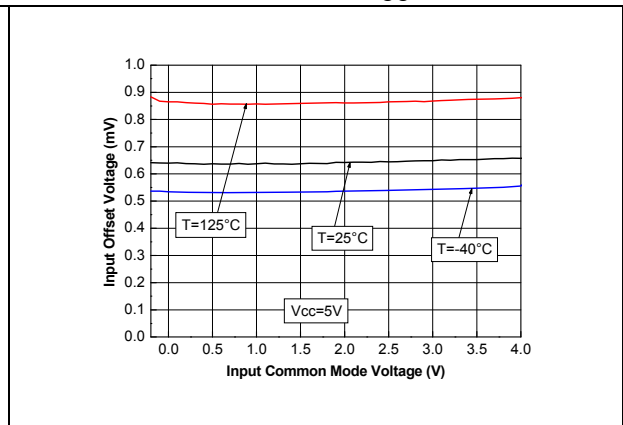

Figure 4. Output current vs. output voltage at  $V_{CC} = 2.7\text{ V}$

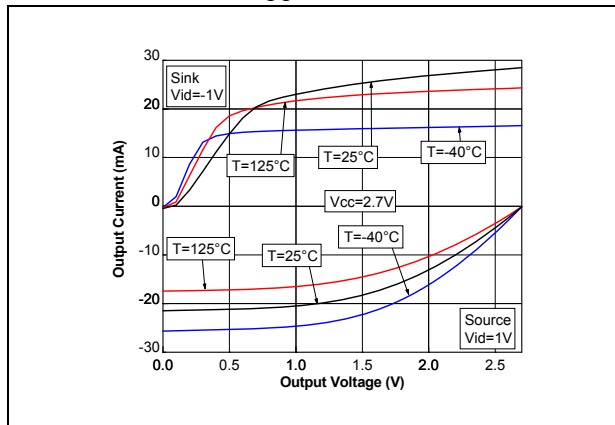

Figure 5. Output current vs. output voltage at  $V_{CC} = 5\text{ V}$

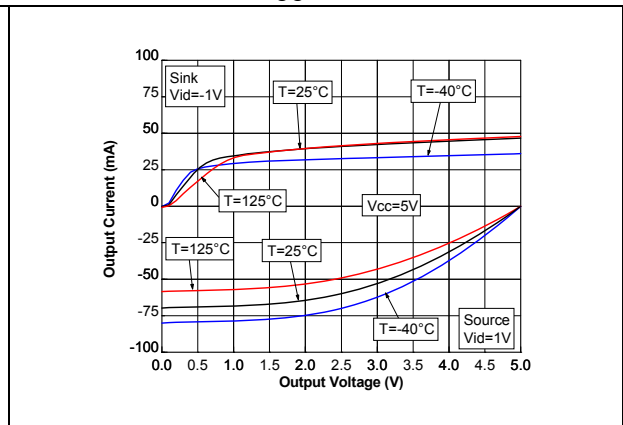

Figure 6. Output current vs. supply voltage at  $V_{icm} = V_{CC}/2$

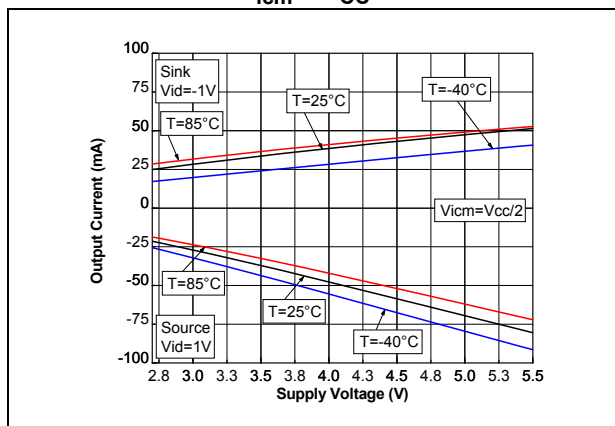

Figure 7. Voltage gain and phase with  $C_I = 200\text{ pF}$

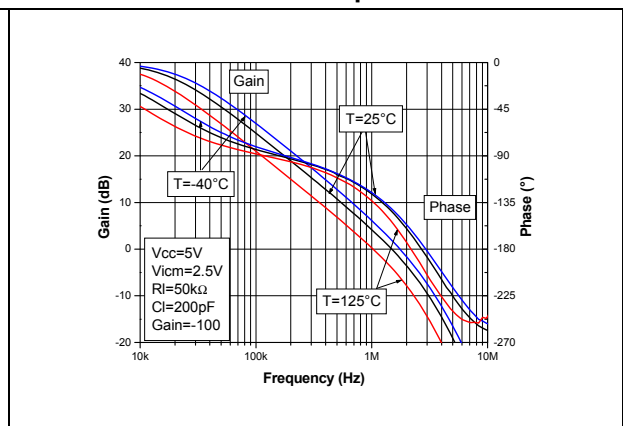

Figure 8. Gain margin vs. load capacitor at  $V_{CC} = 5\text{ V}$

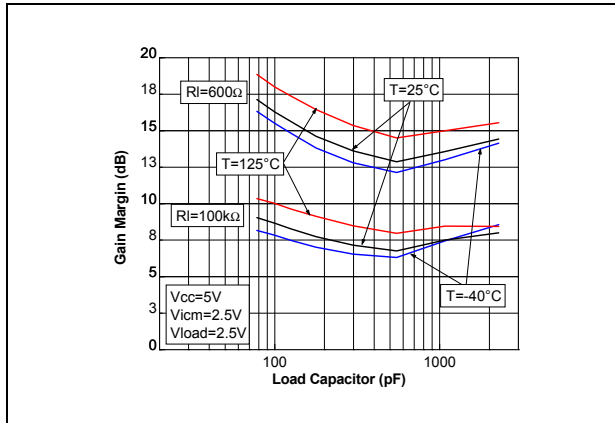

Figure 9. Phase margin vs. load capacitor at  $V_{CC} = 5\text{ V}$

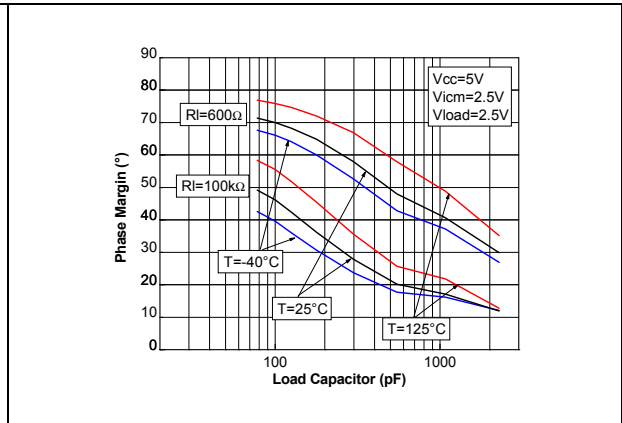

Figure 10. Closed-loop gain in voltage follower configuration for different capacitive loads

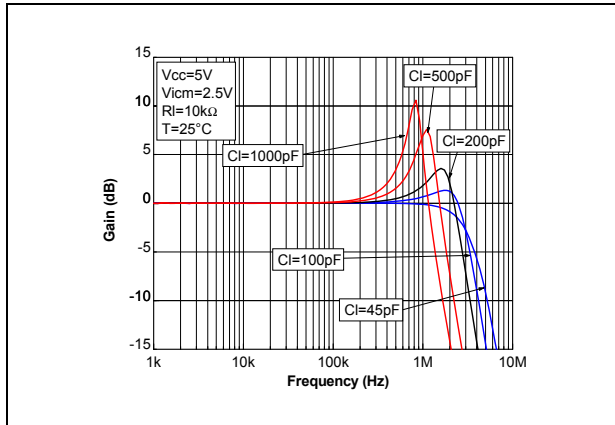

Figure 11. Phase margin vs. output current at  $V_{CC} = 5\text{ V}$

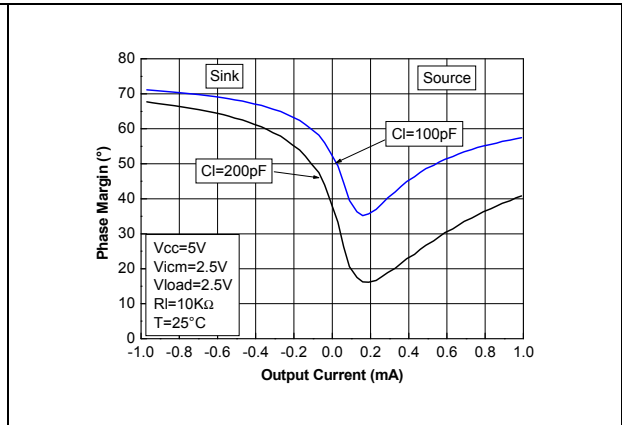

Figure 12. Positive and negative slew rate vs. supply voltage

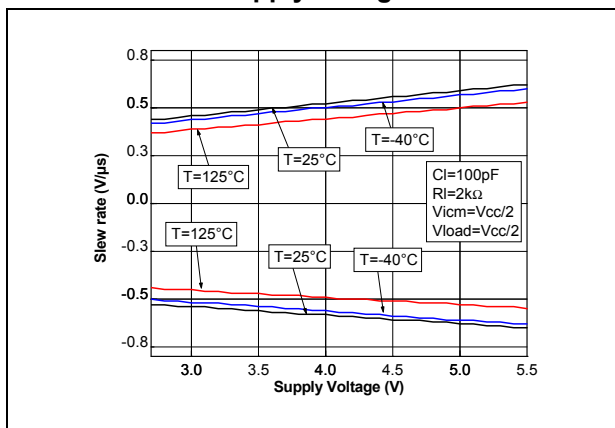

Figure 13. Positive slew rate at  $V_{CC} = 5\text{ V}$  with  $Cl = 100\text{ pF}$

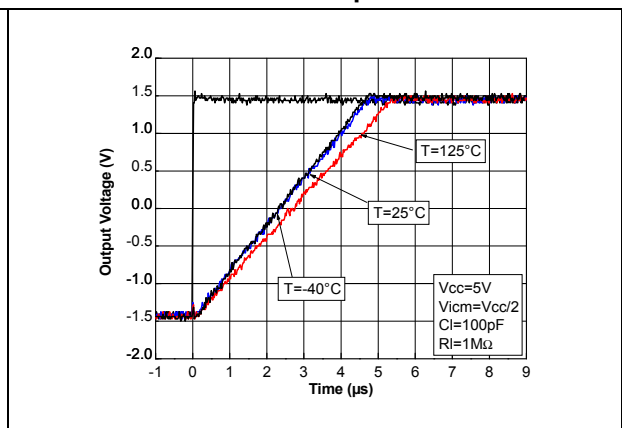

Figure 14. Negative slew rate at  $V_{CC} = 5\text{ V}$  with  $C_I = 100\text{ pF}$

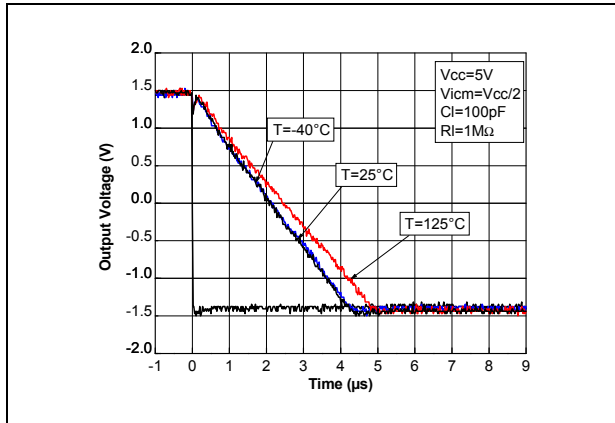

Figure 15. Noise vs. frequency

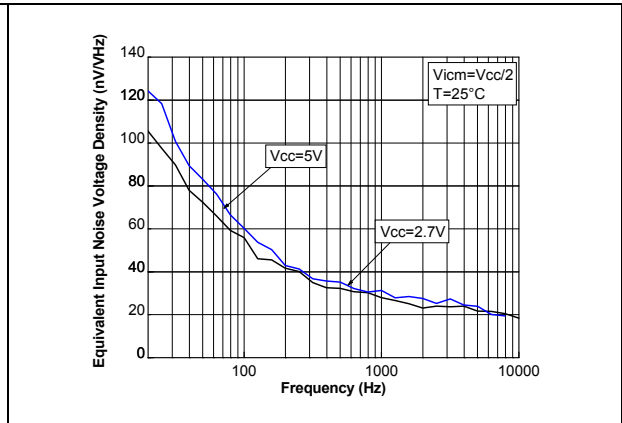

Figure 16. Distortion + noise vs. frequency

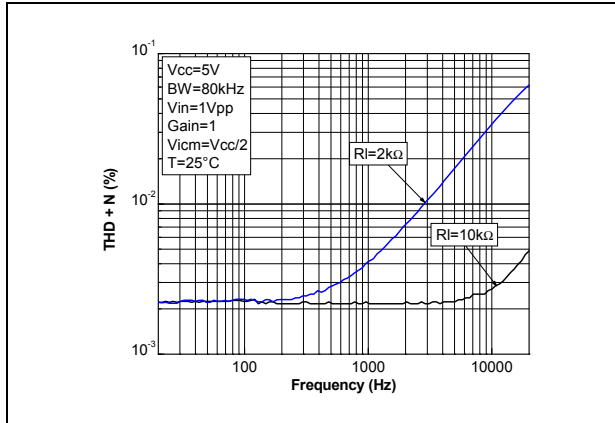
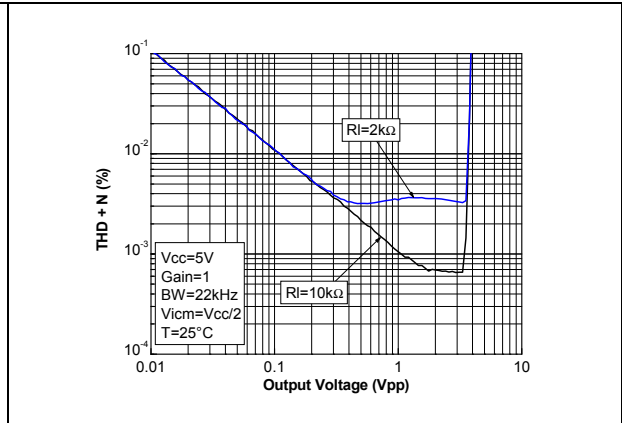

Figure 17. Distortion + noise vs. output voltage



## 4 Application information

### 4.1 Operating voltages

The LMV321L, LMV358L, and LMV324L can operate from 2.7 to 5.5 V. The devices' parameters are fully specified for 2.7 V and 5 V power supplies. Additionally, the main specifications are guaranteed in extended temperature ranges from -40 °C to +125 °C.

### 4.2 Input common-mode range

The LMV321L, LMV358L, and LMV324L have an input common-mode range that includes ground. The input common-mode range is extended from  $V_{CC-} - 0.2$  V to  $V_{CC+} - 1$  V, with no output phase reversal.

### 4.3 Rail-to-rail output

The operational amplifiers' output levels can go close to the rails: 180 mV maximum above and below the rail when connected to a 10 k $\Omega$  resistive load to  $V_{CC}/2$ .

### 4.4 Input offset voltage drift over temperature

The maximum input voltage drift over the temperature variation is defined as follows.

$$\frac{\Delta V_{io}}{\Delta T} = \max \left| \frac{V_{io}(T) - V_{io}(25^\circ \text{C})}{T - 25^\circ \text{C}} \right|$$

for  $T_{\min} < T < T_{\max}$ .

### 4.5 PCB layouts

For correct operation, it is advised to add 10 nF decoupling capacitors as close as possible to the power supply pins.

### 4.6 Macromodel

Accurate macromodels of the LMV321L, LMV358L, and LMV324L are available on STMicroelectronics' web site at [www.st.com](http://www.st.com). These models are a trade-off between accuracy and complexity (that is, time simulation) of the LMV321L, LMV358L, and LMV324L operational amplifiers. They emulate the nominal performances of a typical device within the specified operating conditions mentioned in the datasheet. They also help to validate a design approach and to select the right operational amplifier, *but they do not replace on-board measurements*.

## 5 Package information

In order to meet environmental requirements, ST offers these devices in different grades of ECOPACK<sup>®</sup> packages, depending on their level of environmental compliance. ECOPACK<sup>®</sup> specifications, grade definitions and product status are available at: [www.st.com](http://www.st.com). ECOPACK<sup>®</sup> is an ST trademark.

### 5.1 SC70-5 (SOT323-5) package information

Figure 18. SC70-5 (SOT323-5) package mechanical drawing

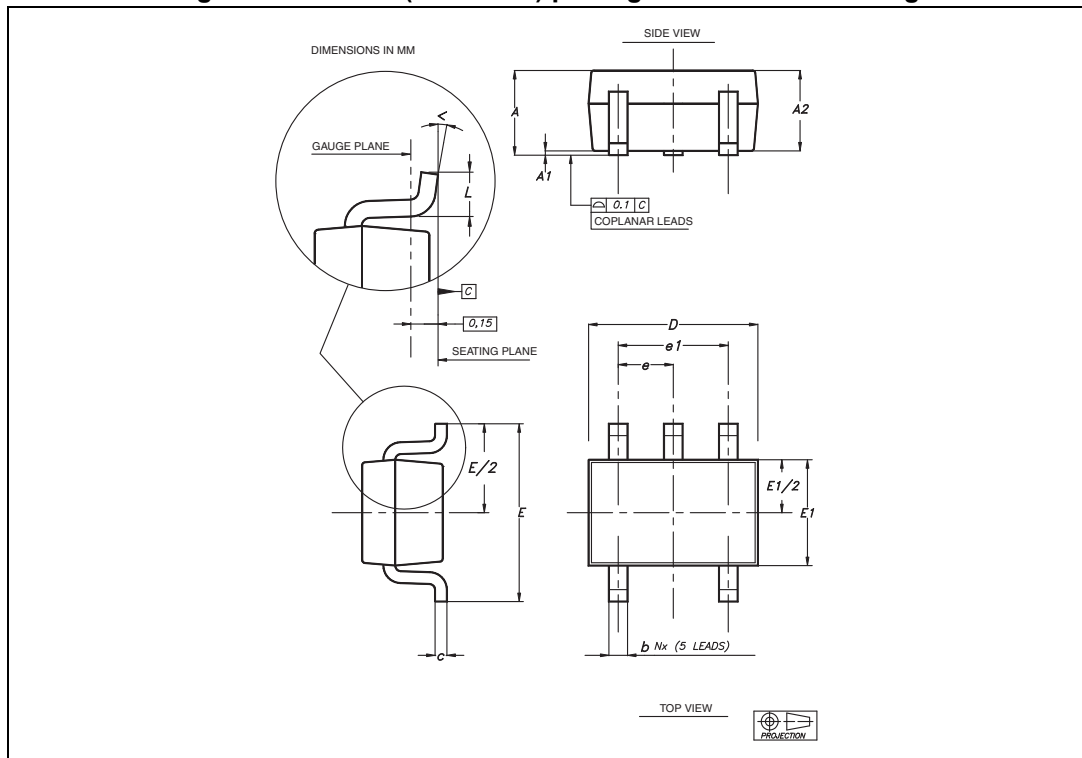

Table 5. SC70-5 (or SOT323-5) package mechanical data

Ref	Dimensions					
	Millimeters			Inches		
	Min	Typ	Max	Min	Typ	Max
A	0.80		1.10	0.315		0.043
A1			0.10			0.004
A2	0.80	0.90	1.00	0.315	0.035	0.039
b	0.15		0.30	0.006		0.012
c	0.10		0.22	0.004		0.009
D	1.80	2.00	2.20	0.071	0.079	0.087
E	1.80	2.10	2.40	0.071	0.083	0.094
E1	1.15	1.25	1.35	0.045	0.049	0.053
e		0.65			0.025	
e1		1.30			0.051	
L	0.26	0.36	0.46	0.010	0.014	0.018
$\alpha$	0°		8°	0°		8°

## 5.2 SOT23-5 package information

Figure 19. SOT23-5 package mechanical drawing

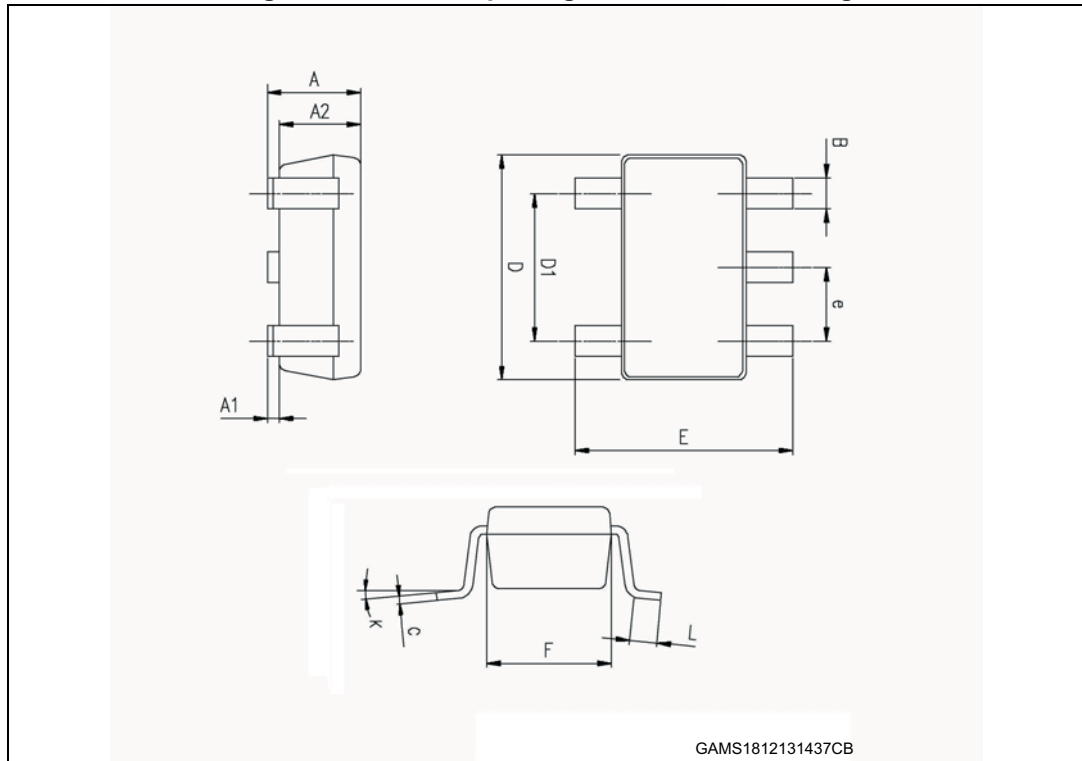

Table 6. SOT23-5 package mechanical data

Ref.	Dimensions					
	Millimeters			Inches		
	Min.	Typ.	Max.	Min.	Typ.	Max.
A	0.90	1.20	1.45	0.035	0.047	0.057
A1			0.15			0.006
A2	0.90	1.05	1.30	0.035	0.041	0.051
B	0.35	0.40	0.50	0.013	0.015	0.019
C	0.09	0.15	0.20	0.003	0.006	0.008
D	2.80	2.90	3.00	0.110	0.114	0.118
D1		1.90			0.075	
e		0.95			0.037	
E	2.60	2.80	3.00	0.102	0.110	0.118
F	1.50	1.60	1.75	0.059	0.063	0.069
L	0.10	0.35	0.60	0.004	0.013	0.023
K	0 °		10 °	0 °		10 °

### 5.3 MiniSO8 package information

Figure 20. MiniSO8 package mechanical drawing

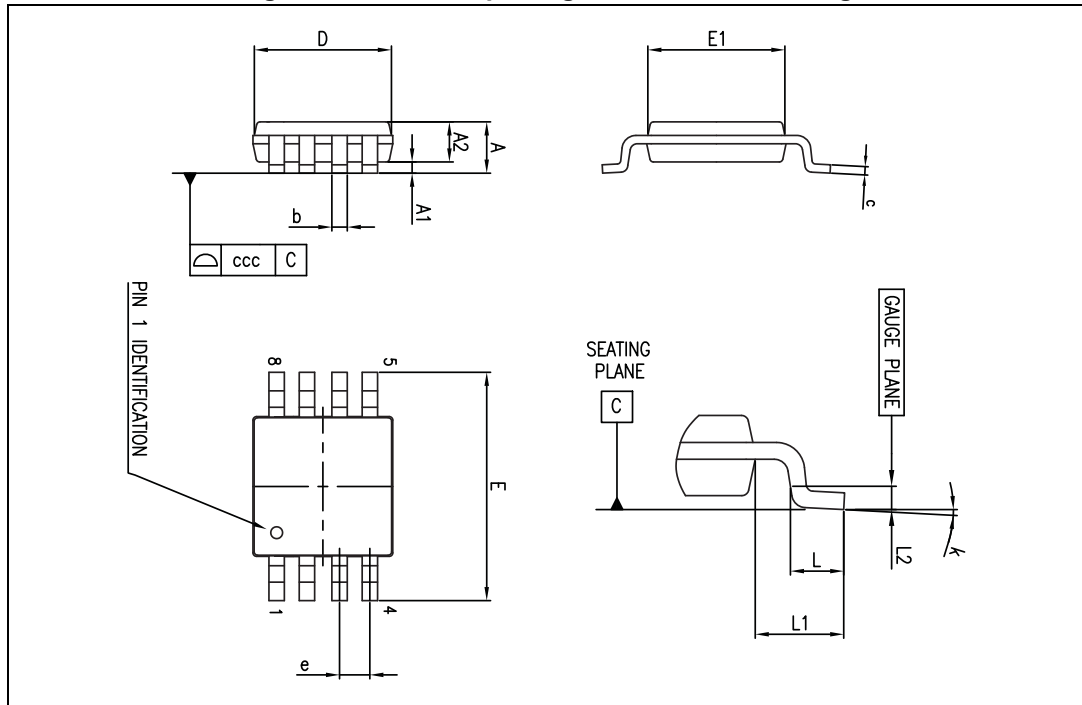

Table 7. MiniSO8 package mechanical data

Ref.	Dimensions					
	Millimeters			Inches		
	Min.	Typ.	Max.	Min.	Typ.	Max.
A			1.1			0.043
A1	0		0.15	0		0.006
A2	0.75	0.85	0.95	0.030	0.033	0.037
b	0.22		0.40	0.009		0.016
c	0.08		0.23	0.003		0.009
D	2.80	3.00	3.20	0.11	0.118	0.126
E	4.65	4.90	5.15	0.183	0.193	0.203
E1	2.80	3.00	3.10	0.11	0.118	0.122
e		0.65			0.026	
L	0.40	0.60	0.80	0.016	0.024	0.031
L1		0.95			0.037	
L2		0.25			0.010	
k	0°		8°	0°		8°
ccc			0.10			0.004

### 5.4 SO8 package information

Figure 21. SO8 package mechanical drawing

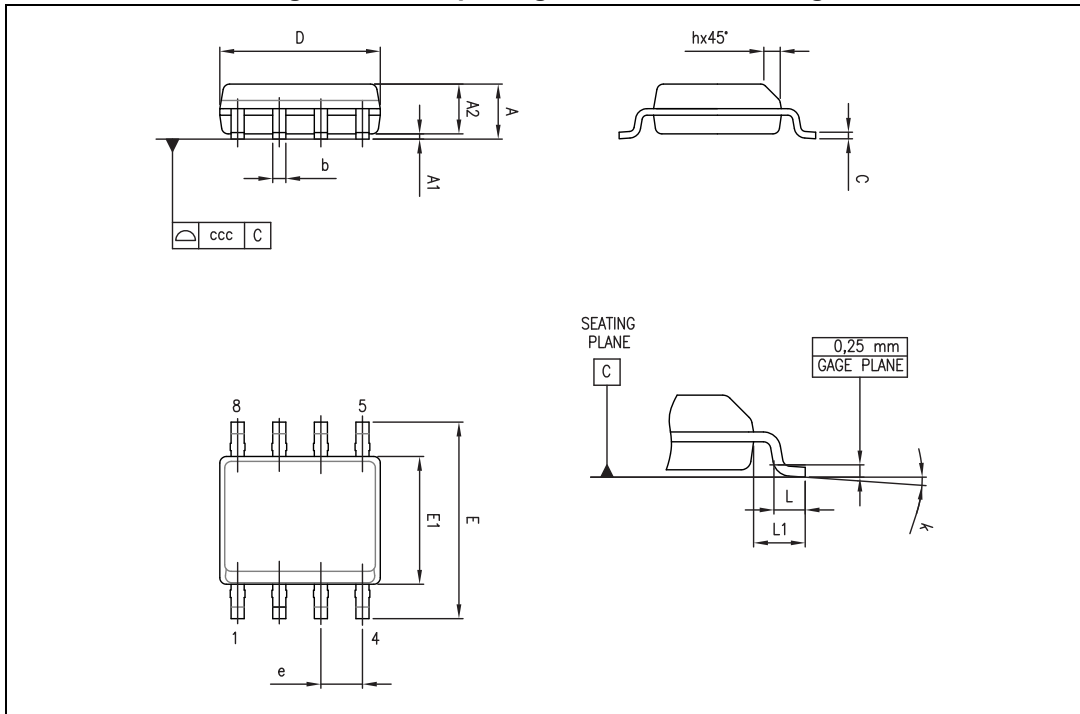

Table 8. SO8 package mechanical data

Ref.	Dimensions					
	Millimeters			Inches		
	Min.	Typ.	Max.	Min.	Typ.	Max.
A			1.75			0.069
A1	0.10		0.25	0.004		0.010
A2	1.25			0.049		
b	0.28		0.48	0.011		0.019
c	0.17		0.23	0.007		0.010
D	4.80	4.90	5.00	0.189	0.193	0.197
E	5.80	6.00	6.20	0.228	0.236	0.244
E1	3.80	3.90	4.00	0.150	0.154	0.157
e		1.27			0.050	
h	0.25		0.50	0.010		0.020
L	0.40		1.27	0.016		0.050
L1		1.04			0.040	
k	0°		8°	1°		8°
ccc			0.10			0.004

### 5.5 TSSOP14 package information

Figure 22. TSSOP14 package mechanical drawing

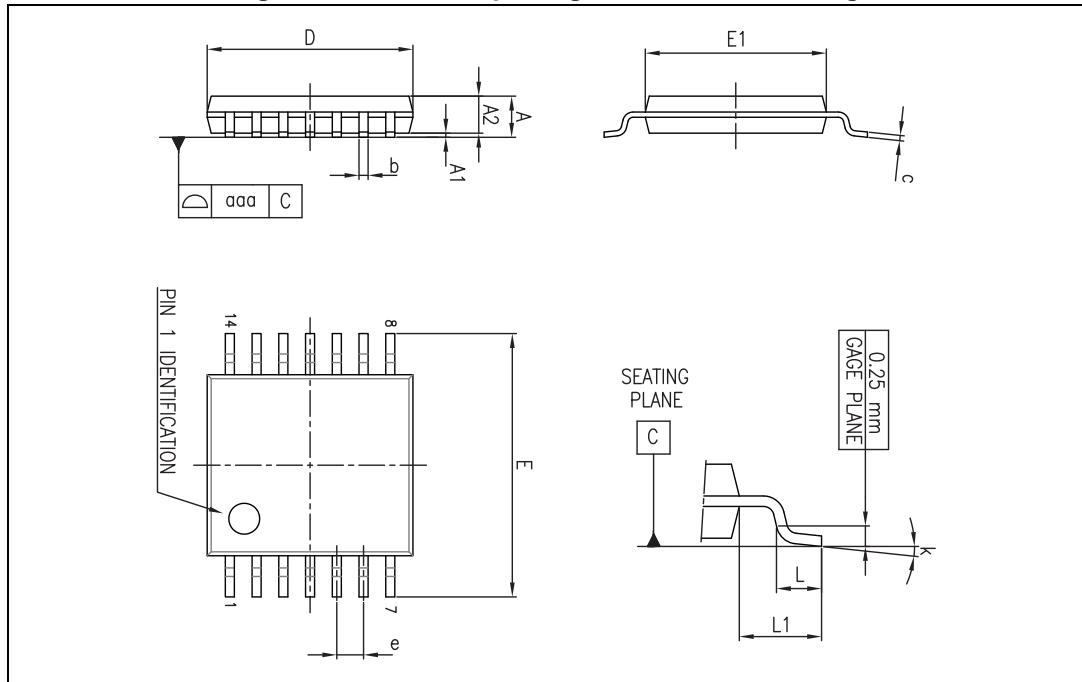

Table 9. TSSOP14 package mechanical data

Ref.	Dimensions					
	Millimeters			Inches		
	Min.	Typ.	Max.	Min.	Typ.	Max.
A			1.20			0.047
A1	0.05		0.15	0.002	0.004	0.006
A2	0.80	1.00	1.05	0.031	0.039	0.041
b	0.19		0.30	0.007		0.012
c	0.09		0.20	0.004		0.0089
D	4.90	5.00	5.10	0.193	0.197	0.201
E	6.20	6.40	6.60	0.244	0.252	0.260
E1	4.30	4.40	4.50	0.169	0.173	0.176
e		0.65			0.0256	
L	0.45	0.60	0.75	0.018	0.024	0.030
L1		1.00			0.039	
k	0°		8°	0°		8°
aaa			0.10			0.004

### 5.6 SO14 package information

Figure 23. SO14 package mechanical drawing

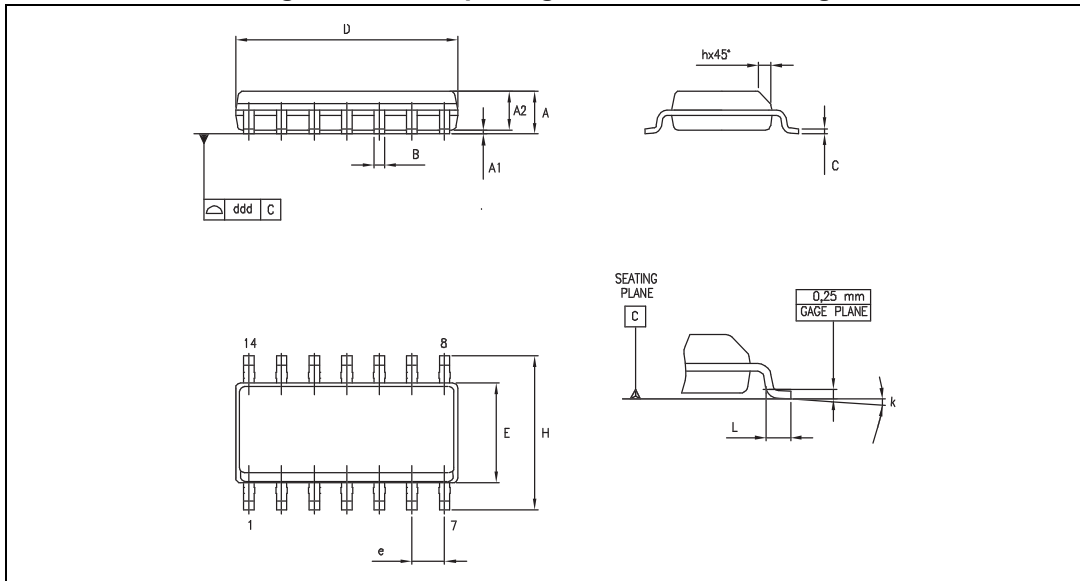

Table 10. SO14 package mechanical data

Dimensions						
Ref.	Millimeters			Inches		
	Min.	Typ.	Max.	Min.	Typ.	Max.
A	1.35		1.75	0.05		0.068
A1	0.10		0.25	0.004		0.009
A2	1.10		1.65	0.04		0.06
B	0.33		0.51	0.01		0.02
C	0.19		0.25	0.007		0.009
D	8.55		8.75	0.33		0.34
E	3.80		4.0	0.15		0.15
e		1.27			0.05	
H	5.80		6.20	0.22		0.24
h	0.25		0.50	0.009		0.02
L	0.40		1.27	0.015		0.05
k	8° (max.)					
ddd			0.10			0.004

## 6 Ordering information

Table 11. Order codes for devices without shutdown feature

Order code	Temperature range	Package	Packing	Marking
LMV321LICT	-40° C to +125 ° C	SC70-5	Tape and reel	K25
LMV321LILT		SOT23-5		K170
LMV358LIST		MiniSO8		K170
LMV358LIDT		SO8		LMV358L
LMV324LIPT		TSSOP14		LMV324L
LMV324LIDT		SO14		LMV324L

## 7 Revision history

Table 12. Document revision history

Date	Revision	Changes
04-May-2012	1	Initial release.
19-Dec-2013	2	New template

**Please Read Carefully:**

Information in this document is provided solely in connection with ST products. STMicroelectronics NV and its subsidiaries ("ST") reserve the right to make changes, corrections, modifications or improvements, to this document, and the products and services described herein at any time, without notice.

All ST products are sold pursuant to ST's terms and conditions of sale.

Purchasers are solely responsible for the choice, selection and use of the ST products and services described herein, and ST assumes no liability whatsoever relating to the choice, selection or use of the ST products and services described herein.

No license, express or implied, by estoppel or otherwise, to any intellectual property rights is granted under this document. If any part of this document refers to any third party products or services it shall not be deemed a license grant by ST for the use of such third party products or services, or any intellectual property contained therein or considered as a warranty covering the use in any manner whatsoever of such third party products or services or any intellectual property contained therein.

**UNLESS OTHERWISE SET FORTH IN ST'S TERMS AND CONDITIONS OF SALE ST DISCLAIMS ANY EXPRESS OR IMPLIED WARRANTY WITH RESPECT TO THE USE AND/OR SALE OF ST PRODUCTS INCLUDING WITHOUT LIMITATION IMPLIED WARRANTIES OF MERCHANTABILITY, FITNESS FOR A PARTICULAR PURPOSE (AND THEIR EQUIVALENTS UNDER THE LAWS OF ANY JURISDICTION), OR INFRINGEMENT OF ANY PATENT, COPYRIGHT OR OTHER INTELLECTUAL PROPERTY RIGHT.**

**ST PRODUCTS ARE NOT DESIGNED OR AUTHORIZED FOR USE IN: (A) SAFETY CRITICAL APPLICATIONS SUCH AS LIFE SUPPORTING, ACTIVE IMPLANTED DEVICES OR SYSTEMS WITH PRODUCT FUNCTIONAL SAFETY REQUIREMENTS; (B) AERONAUTIC APPLICATIONS; (C) AUTOMOTIVE APPLICATIONS OR ENVIRONMENTS, AND/OR (D) AEROSPACE APPLICATIONS OR ENVIRONMENTS. WHERE ST PRODUCTS ARE NOT DESIGNED FOR SUCH USE, THE PURCHASER SHALL USE PRODUCTS AT PURCHASER'S SOLE RISK, EVEN IF ST HAS BEEN INFORMED IN WRITING OF SUCH USAGE, UNLESS A PRODUCT IS EXPRESSLY DESIGNATED BY ST AS BEING INTENDED FOR "AUTOMOTIVE, AUTOMOTIVE SAFETY OR MEDICAL" INDUSTRY DOMAINS ACCORDING TO ST PRODUCT DESIGN SPECIFICATIONS. PRODUCTS FORMALLY ESCC, QML OR JAN QUALIFIED ARE DEEMED SUITABLE FOR USE IN AEROSPACE BY THE CORRESPONDING GOVERNMENTAL AGENCY.**

Resale of ST products with provisions different from the statements and/or technical features set forth in this document shall immediately void any warranty granted by ST for the ST product or service described herein and shall not create or extend in any manner whatsoever, any liability of ST.

ST and the ST logo are trademarks or registered trademarks of ST in various countries.

Information in this document supersedes and replaces all information previously supplied.

The ST logo is a registered trademark of STMicroelectronics. All other names are the property of their respective owners.

© 2013 STMicroelectronics - All rights reserved

STMicroelectronics group of companies

Australia - Belgium - Brazil - Canada - China - Czech Republic - Finland - France - Germany - Hong Kong - India - Israel - Italy - Japan - Malaysia - Malta - Morocco - Philippines - Singapore - Spain - Sweden - Switzerland - United Kingdom - United States of America

[www.st.com](http://www.st.com)