

Ordering number C11816
Description 1

Family	Strada-SQ	FWHM	(simulated)
Type	Lens	Efficiency	(simulated) 0 %
LED	Double Dome (GM2BB)	cd/lm	-
Color	Clear	Gerber File	Available
Diameter	25 + 25 mm		
Height	8.77 mm		
Style	Square		
Optic Material	PMMA		
Holder Material	-		
Fastening	-		
Status	Ready		

Ordering number CA11817
Description 1

Family	Strada-SQ	FWHM	(simulated)
Type	Assembly	Efficiency	(simulated) 0 %
LED	Double Dome (GM2BB)	cd/lm	-
Color	Clear	Gerber File	Available
Diameter	25 + 25 mm		
Height	8.92 mm		
Style	Square		
Optic Material	PMMA		
Holder Material	-		
Fastening	-		
Status	Ready		



PRODUCT DATASHEET
Strada-SQ series
last update 8/3/2013

SHARP

NOTE: The typical divergence will be changed by different color, chip size and chip position tolerance. The typical total divergence is the full angle measured where the luminous intensity is half of the peak value.

D C B A

4

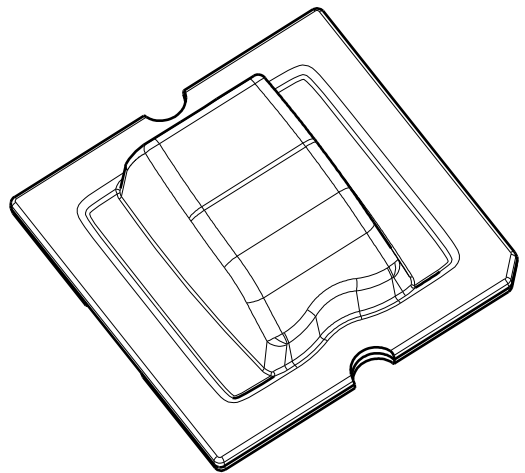

Isometric view

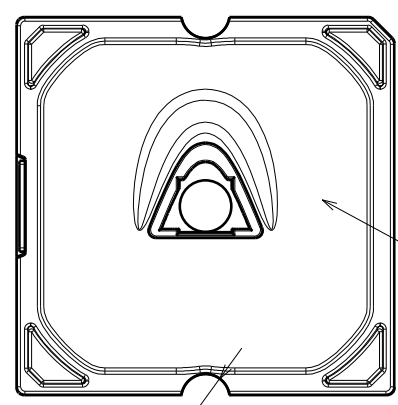

Tape area

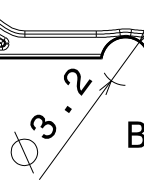

Bottom view

3

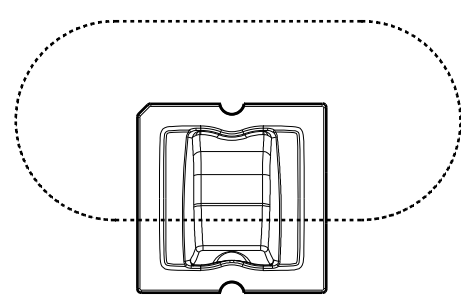

Beam direction

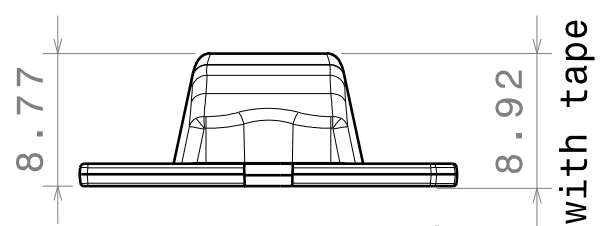

Front view

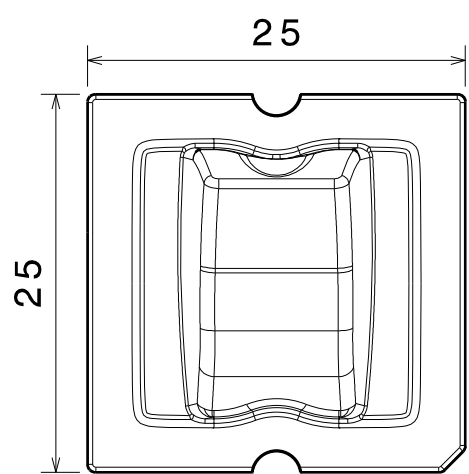

Top view

2

Part no.s:
C11816_Strada-SQ-T-DN-XP
C11816_Strada-SQ-T-DN-XP-G

Part no.s with tape:
CA11817_Strada-SQ-T-DN-XP-TAPE
CA11817_Strada-SQ-T-DN-XP-G-TAPE

MATERIALS
Lens: PMMA
Tape(optional): PU Foam

1

This drawing is our property.
It can't be reproduced
or communicated without
our written agreement.



Ledil Oy
Tehdaskatu 13
FIN-24100 SALO
Finland

DRAWING TITLE

Datasheet Strada-SQ-T-DN-XP Lens

DRAWN BY
mav

DATE
01.12.2010

CHECKED BY
pv

DATE
01.12.2010

SIZE
A4

DRAWING NUMBER
C11816

REV
1

DESIGNED BY
hh

DATE
01.12.2010

SCALE 2:1

WEIGHT (g)

SHEET

1 / 1

D A